

FHA Mini Series

Servo Actuators



Harmonic Drive[®] actuator

P r e c i s i o n G e a r i n g & M o t i o n C o n t r o l



SAFETY GUIDE

For actuators, motors, control units and drivers
manufactured by Harmonic Drive LLC



Read this manual thoroughly before designing the application, installation, maintenance or inspection of the actuator.



WARNING

Indicates a potentially hazardous situation, which, if not avoided, could result in death or serious personal injury.



CAUTION

Indicates a potentially hazardous situation, which, if not avoided, may result in minor or moderate personal injury and/or damage to the equipment.

LIMITATION OF APPLICATIONS:



The equipment listed in this document may not be used for the applications listed below:

- * Space equipment
- * Aircraft, aeronautic equipment
- * Nuclear equipment
- * Household apparatus
- * Vacuum equipment
- * Automobile, automotive parts
- * Amusement equipment, sport equipment, game machines
- * Machine or devices acting directly on the human body
- * Instruments or devices to transport or carry people
- * Apparatus or devices used in special environments





If the above list includes your intending application for our products, please consult us.

Safety measures are essential to prevent accidents resulting in death, injury or damage of the equipment due to malfunction or faulty operation.





CAUTIONS FOR ACTUATORS AT APPLICATION DESIGNING

 <p>CAUTION</p> <ul style="list-style-type: none"> Always use under followings conditions: <ul style="list-style-type: none"> -Ambient temperature: 0 °C to 40 °C -Ambient humidity: 20% to 80%RH (Non-condensation) -Vibration: Max 24.5 m/S² -No contamination by water, oil -No corrosive or explosive gas 	 <p>CAUTION</p> <ul style="list-style-type: none"> Follow exactly the instructions in the relating manuals to install the actuator in the equipment. -Ensure exact alignment of actuator shaft center and corresponding center in the application. Failure to observe this caution may lead to vibration, resulting in damage of output elements.
---	--





CAUTION FOR ACTUATORS IN OPERATIONS

 <p>CAUTION</p> <ul style="list-style-type: none"> Keep limited torques of the actuator. <ul style="list-style-type: none"> -Keep limited torques of the actuator. -Be aware, that if arms attached to output element hits by accident an solid, the output element may be uncontrollable. 	 <p>WARNING</p> <ul style="list-style-type: none"> Never connect cables directly to a power supply socket. -Each actuator must be operated with a proper driver. -Failure to observe this caution may lead to injury, fire or damage of the actuator.
 <p>WARNING</p> <ul style="list-style-type: none"> Do not apply impacts and shocks <ul style="list-style-type: none"> -Do not use a hammer during installation -Failure to observe this caution could damage the encoder and may cause uncontrollable operation. 	 <p>WARNING</p> <ul style="list-style-type: none"> Avoid handling of actuators by cables. -Failure to observe this caution may damage the wiring, causing uncontrollable or faulty operation.

CAUTIONS FOR DRIVERS AT APPLICATION DESIGNING

 <p>CAUTION</p> <ul style="list-style-type: none"> Always use drivers under followings conditions: <ul style="list-style-type: none"> -Mount in a vertical position keeping sufficient distance to other devices to let heat generated by the driver radiate freely. -Ambient temperature: 0 °C to 50 °C -Ambient humidity: less than 95% RH (Non condensation) -No contamination by water, oil or foreign matters -No corrosive, inflammable or explosive gas 	 <p>CAUTION</p> <ul style="list-style-type: none"> Use sufficient noise suppressing means and safe grounding. -Keep signal and power leads separated. -Keep leads as short as possible. -Ground actuator and driver at one single point, minimum ground resistance class: D (less than 100 ohms) -Do not use a power line filter in the motor circuit.
 <p>CAUTION</p> <ul style="list-style-type: none"> Pay attention to negative torque by inverse load. <ul style="list-style-type: none"> -Inverse load may cause damages of drivers. -Please consult our sales office, if you intent to apply products for inverse load. 	 <p>CAUTION</p> <ul style="list-style-type: none"> Use a fast-response type ground-fault detector designed for PWM inverters. -Do not use a time-delay-type ground-fault detector.

CAUTION FOR DRIVERS IN OPERATIONS

 <p>WARNING</p> <ul style="list-style-type: none"> Never change wiring while power is active. <ul style="list-style-type: none"> -Make sure of power non-active before servicing the products. -Failure to observe this caution may result in electric shock or personal injury. 	 <p>WARNING</p> <ul style="list-style-type: none"> Do not touch terminals or inspect products at least 5 minutes after turning OFF power. -Otherwise residual electric charges may result in electric shock. -Make installation of products not easy to touch their inner electric components.
 <p>CAUTION</p> <ul style="list-style-type: none"> Do not make a voltage resistance test. <ul style="list-style-type: none"> -Failure to observe this caution may result in damage of the control unit. -Please consult our sales office, if you intent to make a voltage resistance test. 	 <p>CAUTION</p> <ul style="list-style-type: none"> Do not operate control units by means of power ON/OFF switching. -Start/stop operation should be performed via input signals. Failure to observe this caution may result in deterioration of electronic parts.

DISPOSAL OF AN ACTUATOR, A MOTOR, A CONTROL UNIT AND/OR THEIR PARTS

 <p>CAUTION</p> <ul style="list-style-type: none"> All products or parts have to be disposed of as industrial waste. -Since the case or the box of drivers have a material indication, classify parts and dispose them separately.
--

Contents

Chapter 1	Overview of the FHA-C mini series	4
1-1	Features	4
1-2	Ordering information	5
1-3	Combinations with drivers	6
1-4	Specifications of FHA-C mini actuators	7
1-4-1	Supply voltage AC100V/200V	8
1-4-2	Supply voltage DC24V	8
1-5	External dimensions of FHA-C mini actuators	9
1-5-1	Actuators with side-leading cables (standard inc.)	9
1-5-2	Actuators with backward leading cables (optional)	10
1-5-3	Actuators with Absolute Encoder	11
1-6	Mechanical accuracy of FHA-C mini actuators	13
1-7	One-way positioning accuracy	14
1-8	Encoder resolution	14
1-9	Torsional Stiffness of actuators	15
1-9-1	Moment stiffness	15
1-9-2	Torsional stiffness	16
1-10	Rotary direction	17
1-11	Impact resistance	17
1-12	Vibration resistance	17
1-13	Torque-speed characteristics	18
1-14	Operating range	19
1-15	Cable specifications	25
1-15-1	Incremental Encoder	25
1-15-2	Absolute Encoder	26
Chapter 2	Guidelines for sizing	27
2-1	Allowable load inertia	27
2-2	Variable load inertia	27
2-3	Verifying loads	28
2-4	Duty cycles	32
2-4-1	Actuator speed	32
2-4-2	Load inertia	32
2-4-3	Load torque	32
2-4-4	Acceleration time and deceleration time	33
2-4-5	Calculating equivalent duty	34
2-4-6	Effective torque and average speed	37
2-4-7	Permissible overloaded time	38
Chapter 3	Installing the FHA actuator	39
3-1	Receiving Inspection	39
3-2	Notice on handling	41
3-3	Location and installation	41
3-3-1	Environment of location	41
3-3-2	Installation	42
3-4	Extension cable for Absolute Encoder	44
Appendix 1	Incremental encoder detailed specifications	45
Appendix 2	Unit conversion	47
Appendix 3	Moment of inertia	49
3-1	Calculation of mass and moment of inertia	49
3-2	Inertia of cylinder	51
Warranty		52

Chapter 1 Overview of the FHA-C mini series

FHA-C mini series servo actuators provide high torque and highly accurate rotary motion. The actuator is composed of a Harmonic Drive® component from set (size 8 - 14) for precise motion control and a super-flat AC servomotor.

The first feature of the FHA-C mini series actuators is their unprecedented super-flat shape. The body width is less than half of our previous models. The second feature is a through-hole in the center of the shaft, through which electric cables, air pipes, and even laser beams can be passed to supply power and signals to moving parts.

The HA-800 series and the HA-680 series are dedicated servo drivers for the FHA-C mini series actuator to control its position and speed. The small and intelligent driver controls the FHA-C mini series actuators with great accuracy and reliability.

FHA-C mini series actuators play an important role for driving various factory automation (FA) equipment; such as robot joints, alignment mechanisms for semiconductor and LCD equipment, ATC of machine tools, printing machine roller, etc.

1-1 Features

◆ Super-flat configuration

FHA-C mini series actuator is the union of Harmonic Drive® gearing with a super-flat AC servomotor for precise motion control. The compact size allows smaller machines to be designed.

◆ Hollow Shaft*

The center through-hole shaft allows for the insertion of electric cables, air pipes, or laser beams through the actuator to supply power and signals to moving parts. This feature will simplify the driven machine.

◆ High torque

FHA-C mini series actuator outputs have a much higher torque per volume than direct drive motors thanks to Harmonic Drive® gearing. Furthermore, FHA-C mini series actuators have a higher rating than our previous models.

◆ High positioning accuracy

FHA-C mini series actuators provide superior positioning accuracy. They achieve positioning accuracy of 90 arc seconds (typically, FHA-14C-100) as well as an encoder resolution of 800,000 pulses per output revolution.

◆ High torsion stiffness

FHA-C mini series actuators provide great torsion stiffness featuring shortens positioning time and decreases the vibration during servo-lock stop.

◆ Incremental or Absolute encoder

An incremental or multi-turn absolute encoder is integrated to provide high resolution velocity and position feedback

*Incremental encoder only.

1-2 Ordering information

Model codes for the FHA-C mini series actuators are as follows:

Incremental Encoder

FHA-8 C-30-US 200-□

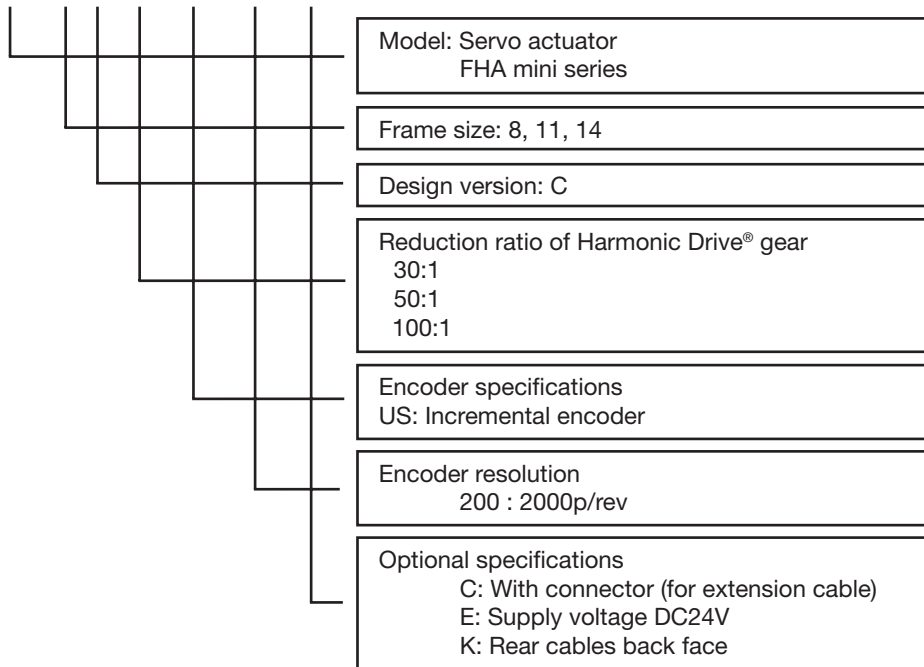

Absolute Encoder

FHA-8 C-50-12S17b □ -C

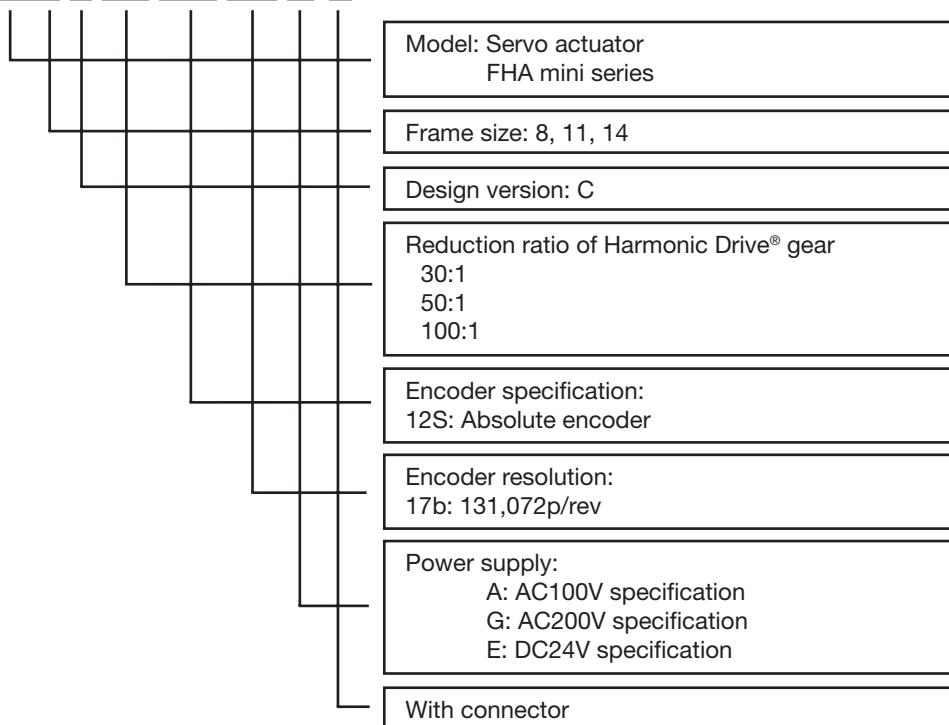

1-3 Combinations with drivers

HA-800 and HA-680 drivers are available for use with FHA-C mini actuators functioning with their nominal current and encoder systems. An FHA-C mini series actuator can be used for both 100V and 200V supply systems. The correct combinations are as follows:

Actuators Size	Input Voltage	Encoder Type	Recommended Drivers		
			General/ CANopen	Ether CAT	General I/O
8, 11, 14	AC 200V	Incremental	RTL-230-18	REL-230-18	HA-800-1-200
	AC 100V		RTL-230-18	REL-230-18	HA-800-1-100
8	DC 24V		DDP-090-09, DCJ-055-09	DEP-090-09	HA-680-4-24
11	DC 24V		DDP-090-09, DCJ-055-18	DEP-090-18	
14	DC 24V		DDP-090-36	DEP-090-36	HA-680-6-24
8, 11, 14	AC 200/100V		Absolute	–	REL-230-18
8	DC 24V	–		DEP-090-09	
11	DC 24V			DEP-090-18	
14	DC 24V			DEP-090-36	

HA-800 & HA-680 are available for MECHATROLINK-II & CC-Link

1-4 Specifications of FHA-C mini actuators

1-4-1 Supply voltage AC100V/200V

Specifications of FHA-C mini series actuators are as follows:

Item		Model	FHA-8C			FHA-11C			FHA-14C		
			30	50	100	30	50	100	30	50	100
Max. torque	Note 2	N·m	1.8	3.3	4.8	4.5	8.3	11	9.0	18	28
		kgf·m	0.18	0.34	0.49	0.46	0.85	1.1	0.92	1.8	2.9
Maximum speed		rpm	200	120	60	200	120	60	200	120	60
Torque constant		N·m/A	3.9	6.7	14	3.8	6.6	13	4.2	7.2	15
		Kgf·m/A	0.40	0.68	1.4	0.39	0.67	1.4	0.43	0.74	1.5
Max. current	Note 2	A	0.61	0.64	0.48	1.5	1.6	1.1	2.9	3.2	2.4
Power supply voltage		V	AC200 or AC100			AC200 or AC100			AC200 or AC100		
EMF constant		V/(rpm)	0.48	0.80	1.6	0.48	0.80	1.6	0.52	0.86	1.70
Phase resistance		Ω (20°C)	14			3.7			1.4		
Phase inductance		mH	5.8			3.4			1.8		
Number of poles			10			10			10		
Moment of Inertia (GD ² /4)	Incremental	kg·m ²	0.0026	0.0074	0.029	0.0060	0.017	0.067	0.018	0.050	0.200
	Absolute	kg·m ²	0.0026	0.0073	0.029	0.0062	0.17	0.069	0.019	0.054	0.215
Reduction ratio			1:30	1:50	1:100	1:30	1:50	1:100	1:30	1:50	1:100
Allowable torsional moment		N·m	15			40			75		
		kgf·m	1.5			4.1			7.7		
Moment stiffness		N·m/rad	2 x 10 ⁴			4 x 10 ⁴			8 x 10 ⁴		
		kgf·m/rad	0.2 x 10 ⁴			0.4 x 10 ⁴			0.8 x 10 ⁴		
Motor encoder	Incremental		2000 pulse/revolution								
	Absolute		Multi-turn 16 bit (65536 revolution), Single (motor) turn 17 bit (131072 pulse/revolution)								
Quad encoder-resolution ¹ Note 4	Incremental	Pulse/rev	240000	400000	800000	240000	400000	800000	240000	400000	800000
	Absolute	Pulse/rev	3,932,160	6,553,600	13,107,200	3,932,160	6,553,600	13,107,200	3,932,160	6,533,600	13,107,200
One-way positioning accuracy		Arc sec	150	120	120	120	90	90	120	90	90
	Compensated		The accuracies are improved 30% of the above values at no disturbances by the compensating function of HA-655 driver Note 5								
Mass	Incremental	kg	0.40			0.62			1.2		
	Absolute	kg	0.50			0.75			1.3		
Enclosure			Totally enclosed, self-cooling (equivalent to IP44, Note 6)								
Environmental conditions			Service / storage temperature: 0~40°C / -20~60°C Service / storage humidity: 20~80%RH (no condensation) Vibration / impact resistance: 25m/s ² (frequency:10-400Hz) / 300 m/s ² No dust, no metal powder, no corrosive gas, no inflammable gas, no oil mist; install in room, no direct sunlight Altitude: less than 1, 000 meters above sea level Magnetic noise resistance: 0.01 telsa (ABS)								
Motor insulation			Insulation resistance: 100MΩ or more (by DC500V insulation tester) Withstanding voltage: AC1500V / 1 minute Insulation class: B								
Safety standard			Compliant with the CE marking								
Orientation			All position								

Note 1: The table shows typical output values of actuators.

Note 2: Values for saturated temperature under the conditions that the actuator is driven by an appropriate driver.

Note 3: All values are typical.

Note 4: Quad encoder resolutions are obtained by [motor encoder resolution] x 4 x [reduction ratio]

Note 5: Refer to the HA-800 manual for details.

Note 6: All parts, except the rotary sliding parts (oil seal) and connectors, are protected against solid bodies of superior dimensions to 1mm, and against the water sprays.

1-4-2 Supply voltage DC24V

Specifications of FHA-C mini series actuators are as follows:

Item		Model	FHA-8C			FHA-11C			FHA-14C		
			30	50	100	30	50	100	30	50	100
Max. torque Note 2	N·m		1.8	3.3	4.8	4.5	8.3	11	9.0	18	28
	kgf·m		0.18	0.34	0.49	0.46	0.85	1.1	0.92	1.8	2.9
Maximum speed	rpm		200	120	60	200	120	60	200	120	60
Torque constant	N·m/A		0.8	1.3	2.7	0.8	1.3	2.6	0.8	1.4	2.9
	Kgf·m/A		0.08	0.13	0.28	0.08	0.13	0.27	0.08	0.14	0.30
Max. current Note 2	A		3.0	3.3	2.4	7.8	8.2	5.6	14.8	16.4	12.3
Allowable continuous current Note 2	A		1.6	1.7	1.3	3.7	3.5	2.8	6	5.4	4.4
Power supply voltage	V		DC24								
EMF constant	V/(rpm)		0.10	0.16	0.32	0.09	0.15	0.31	0.10	0.17	0.34
Phase resistance	$\Omega(20^\circ\text{C})$		0.54			0.19			0.07		
Phase inductance	mH		0.22			0.11			0.06		
Number of poles			10			10			10		
Moment of Inertia (GD ² /4)	Incremental	kg·m ²	0.0026	0.0074	0.029	0.0060	0.017	0.067	0.018	0.050	0.200
	Absolute	kg·m ²	0.0026	0.0073	0.029	0.0062	0.17	0.069	0.019	0.054	0.215
Reduction ratio			1:30	1:50	1:100	1:30	1:50	1:100	1:30	1:50	1:100
Allowable torsional moment	N·m		15			40			75		
	kgf·m		1.5			4.1			7.7		
Moment stiffness	N·m/rad		2×10^4			4×10^4			8×10^4		
	kgf·m/rad		0.2×10^4			0.4×10^4			0.8×10^4		
Motor encoder	Incremental		2000 pulse/revolution								
	Absolute		Multi-turn 16 bit (65536 revolution), Single (motor) turn 17 bit (131072 pulse/revolution)								
Quad encoder-resolution Note 4	Incremental	Pulse/rev	240000	400000	800000	240000	400000	800000	240000	400000	800000
	Absolute	Pulse/rev	3,932,160	6,553,600	13,107,200	3,932,160	6,553,600	13,107,200	3,932,160	6,533,600	13,107,200
One-way positioning accuracy	Arc sec		150	120	120	120	90	90	120	90	90
	Compensated		The accuracies are improved 30% of the above values at no disturbances by the compensating function of HA-655 driver Note 5								
Mass	Incremental	kg	0.40			0.62			1.2		
	Absolute	kg	0.50			0.75			1.3		
Enclosure			Totally enclosed, self-cooling (equivalent to IP44, Note 6)								
Environmental conditions			Service / storage temperature: 0~40°C / -20~60°C Service / storage humidity: 20~80%RH (no condensation) Vibration / impact resistance: 25m/s ² (frequency:10-400Hz) / 300 m/s ² No dust, no metal powder, no corrosive gas, no inflammable gas, no oil mist; install in room, no direct sunlight Altitude: less than 1, 000 meters above sea level								
Motor insulation			Insulation resistance: 100M Ω or more (by DC500V insulation tester) Withstanding voltage: AC1500V / 1 minute Insulation class: B								
Safety standard			Compliant with the CE marking and the UL standard								
Orientation			All position								

Note 1: The table shows typical output values of actuators.

Note 2: Values for saturated temperature under the conditions that the actuator is driven by an appropriate HA-655 or HA-675 driver.

Note 3: All values are typical.

Note 4: Quad encoder resolutions are obtained by [motor encoder resolution] x 4 x [reduction ratio]

Note 5: Refer to the HA-680 manual for details.

Note 6: All parts, except the rotary sliding parts (oil seal) and connectors, are protected against solid bodies of superior dimensions to 1mm, and against the water sprays.

1-5 External dimensions of FHA-C mini actuators

The external drawings are shown as follows:

1-5-1 Actuators with side-leading cables (standard inc.)

■FHA-8C-xxx-US200

Unit: mm (third angle projection)

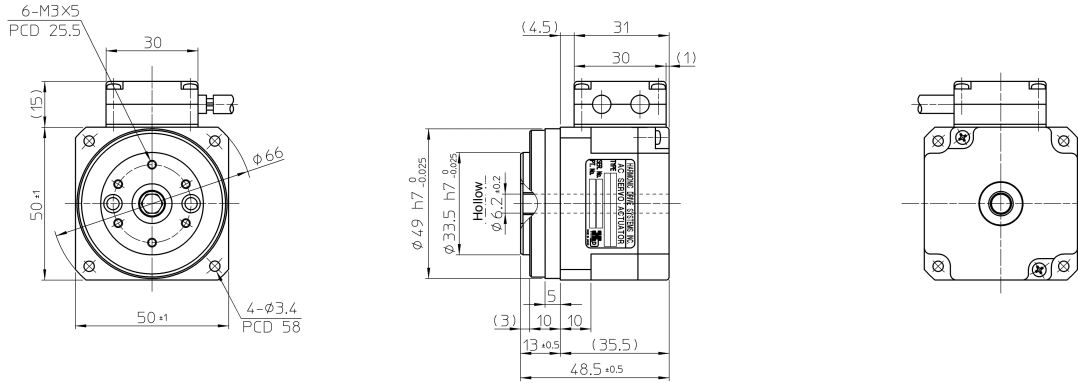

■FHA-11C-xxx-US200

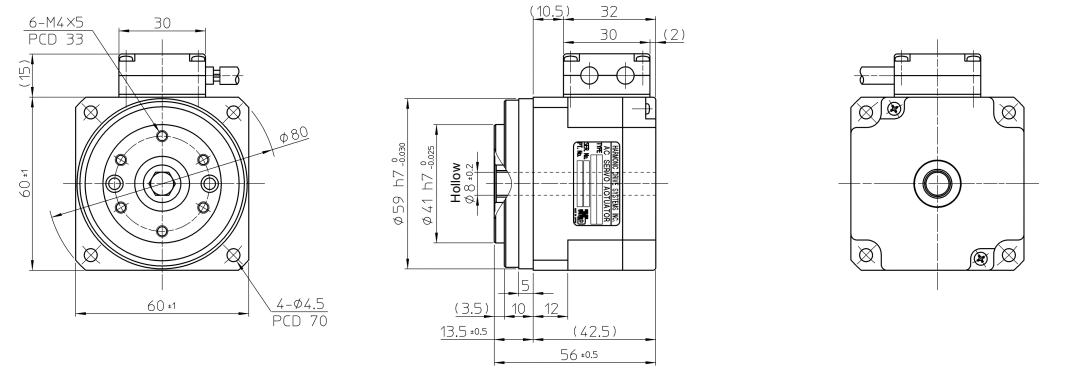

■FHA-14C-xxx-US200

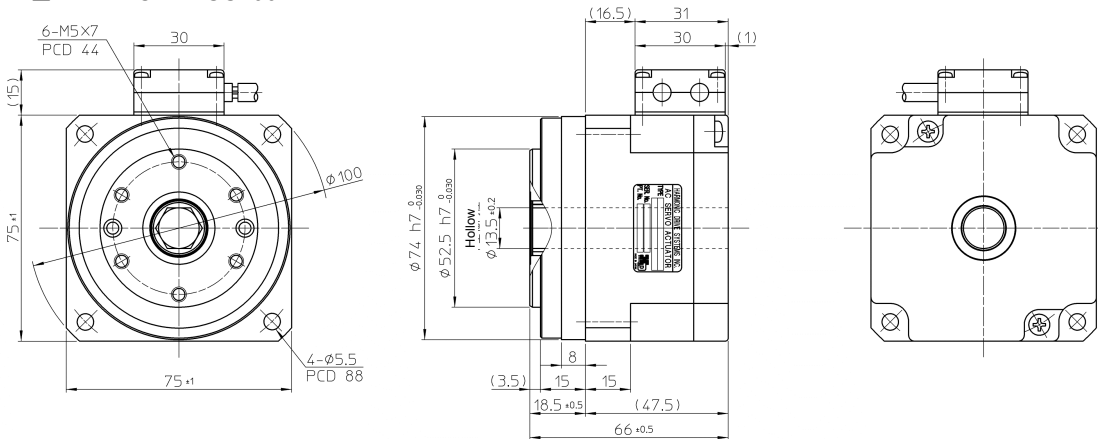

■Cables (common specifications)

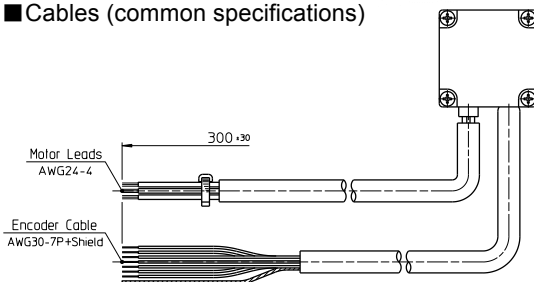

1-5-2 Actuators with backward leading cables (Optional)

■FHA-8C-xxx-US200-□ □ K

Unit: mm (third angle projection)

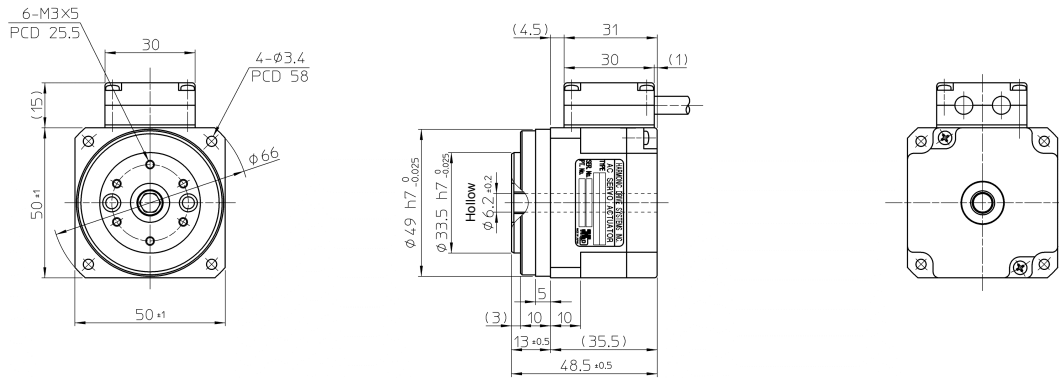

■FHA-11C-xxx-US200-□ □ K

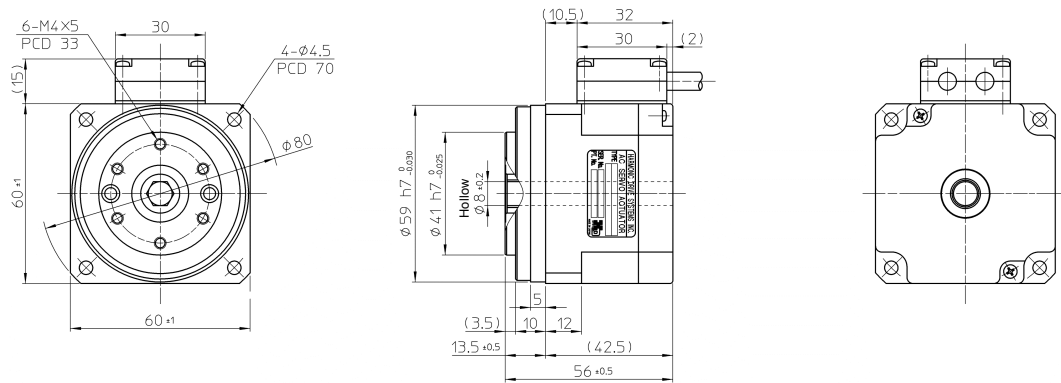

■FHA-14C-xxx-US200-□ □ K

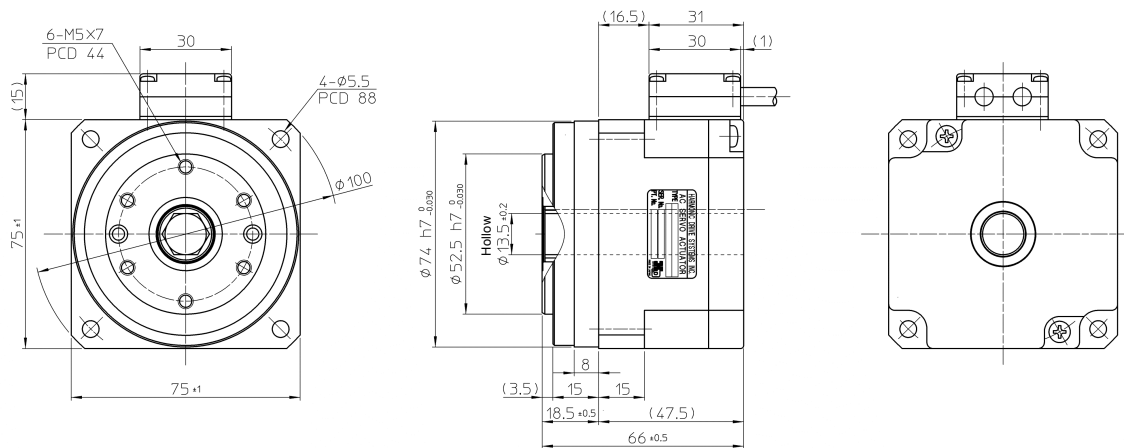

■Cables (common specifications)

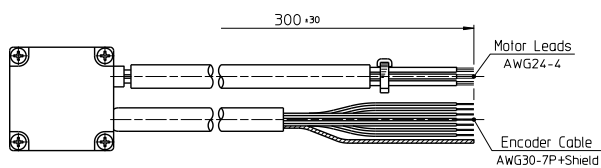

1-5-3 Actuators with Absolute Encoder

■FHA-8C-xxx-12S17b □-C

Unit: mm (third angle projection)

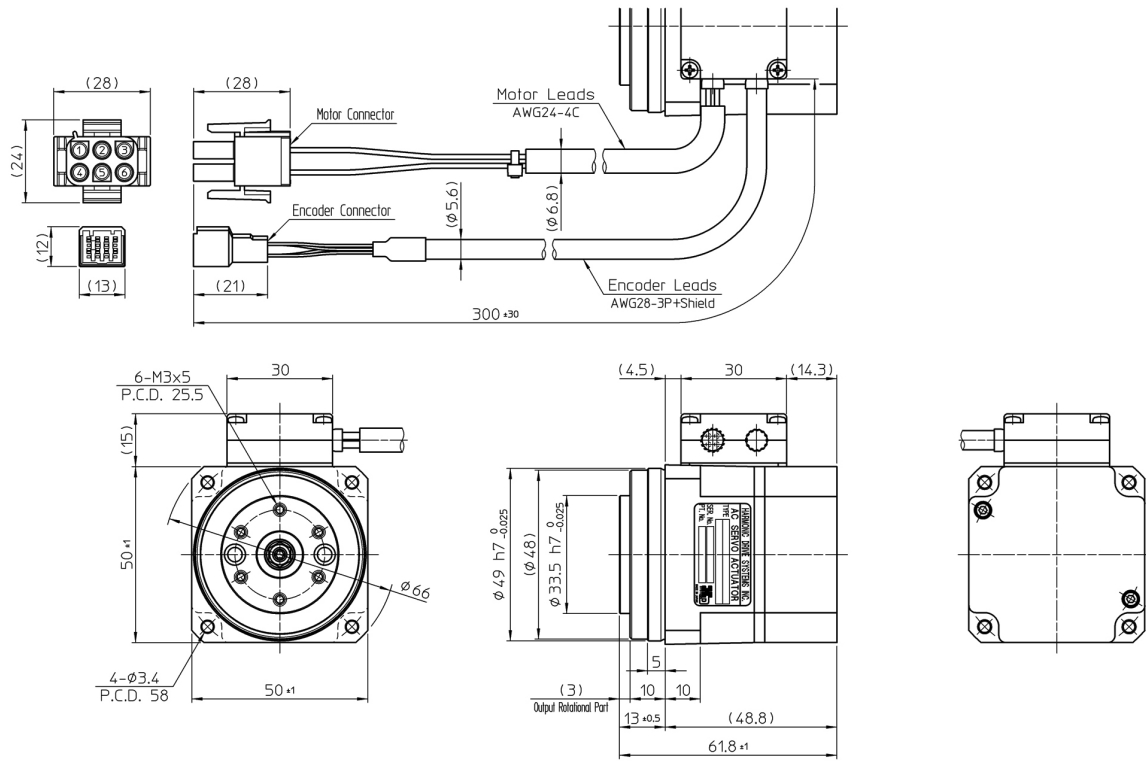

■FHA-11C-xxx-12S17b □-C

Unit: mm (third angle projection)

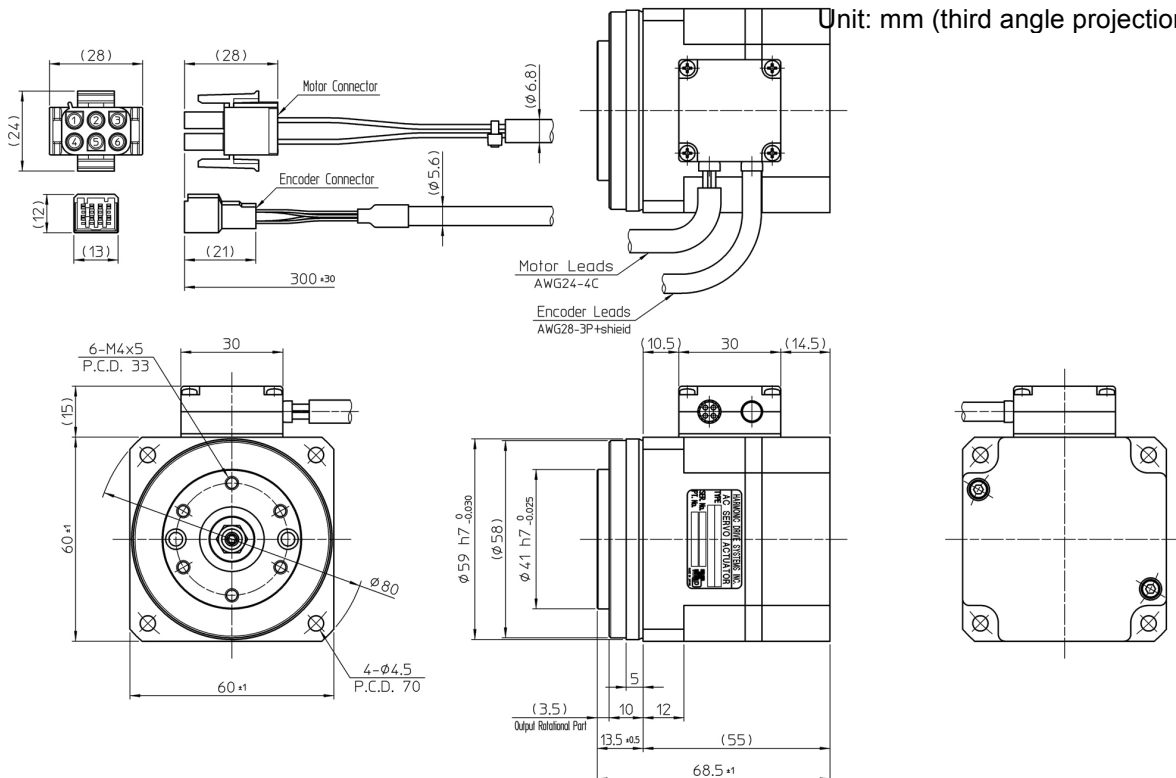

■ FHA-14C-xxx-12S17b □ - C

Unit: mm (third angle projection)

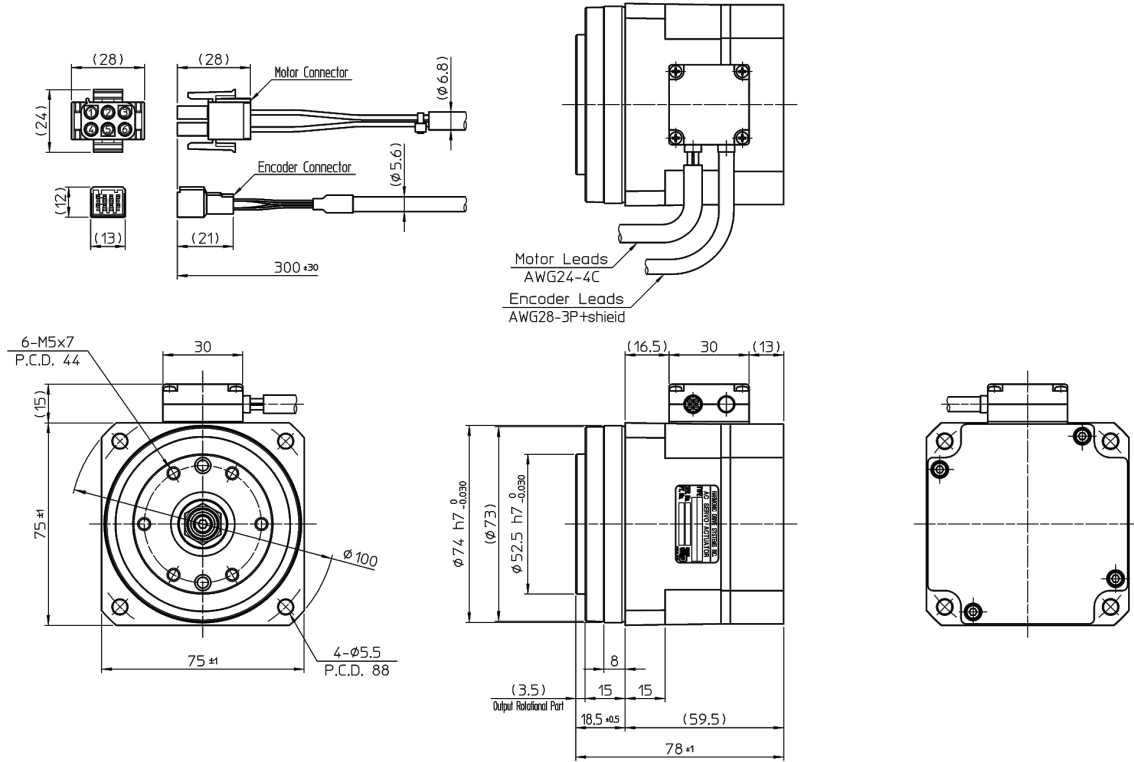

1-6 Mechanical accuracy of FHA-C mini actuators

The machining accuracy of the output flange and the mounting flange are indicated in the table below.

Machined accuracy of the output flange unit: mm

Machined parts	FHA-8C	FHA-11C	FHA-14C
1. Axial run-out of output flange		0.010	
2. Radial run-out of output flange		0.010	
3. Parallelism between output and mounting flange		0.040	
4. Concentricity between output flange to fitting face		0.040	

Note: All values are T.I.R. (Total Indicator Reading).

The measuring for the values are as follows:

◆ Axial run-out of output flange

The dial indicator (1) on a fixed portion measures the axial run-out (T.I.R.) of perimeter of output flange for one revolution.

◆ Radial run-out of output flange

The dial indicator (2) on a fixed portion measures the radial run-out (T.I.R.) of perimeter of output flange for one revolution.

◆ Parallelism between output flange and mounting flange

The dial indicator (3) on the output flange measures the axial run-out (T.I.R.) of each perimeter of both sides of the fixing flange for one revolution.

◆ Concentricity between output flange to fitting face

The dial indicator (4) on the output flange measures the radial run-out (T.I.R.) of each surface of both fitting face (output flange and opposite side) for one revolution.

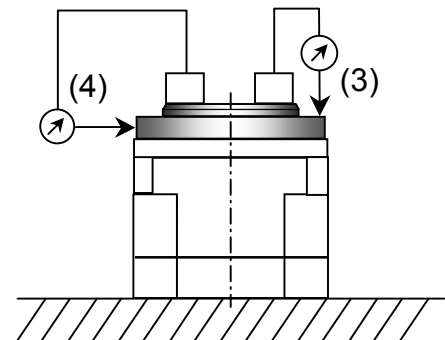
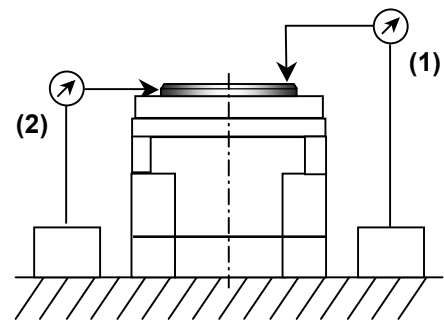
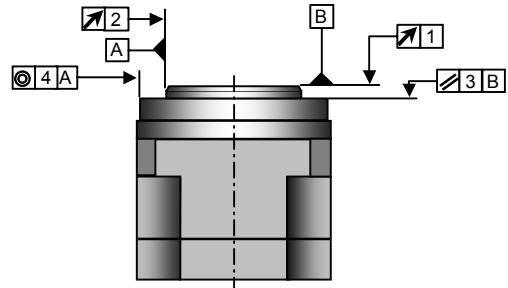

1-7 One-way positioning accuracy

The one-way positioning accuracy means the maximum positional difference between a commanded theoretical position and its actual angular position for serial positioning in one revolution when approached from the same direction. (refer to JIS B-6201-1987.)

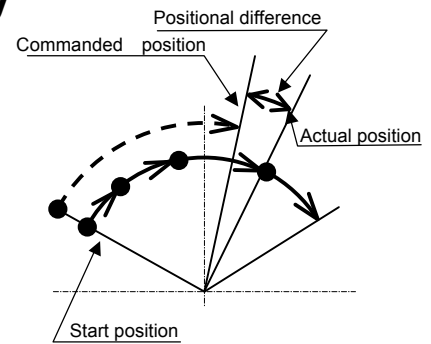

The one-way positioning accuracy of FHA-C mini actuators is almost equal to the angular positioning accuracy of the Harmonic Drive® gearing, because the effect on the positioning error of the built-in motor is reduced to its 30:1 or 50:1 or 100:1 by the gearing.

The one-way positioning accuracy is shown in the table below:

Item	Model	FHA-8C			FHA-11C			FHA-14C		
		-30	-50	-100	-30	-50	-100	-30	-50	-100
One-way positioning accuracy	arc second	150	120	120	120	90	90	120	90	90

● Angle offset function for a horizontally installed actuator

The drivers for FHA-C mini series actuators (FHA-8C/11C/14C) provide an angle offset function to improve angular positioning accuracy of a horizontally installed actuator. The function offsets against a position error by a pre-analyzed positioning error of the Harmonic Drive® components to improve a one-way positioning accuracy by around 30% better than an accuracy without the angle offset function. For fluctuant load, test and examine whether the function is effective before applying it.

Refer to the driver manual.

1-8 Encoder resolution

The motors of FHA-C mini actuators are equipped with an incremental encoder of 2000 resolutions. Because the motor rotation is reduced to 30:1 or 50:1 or 100:1 by the Harmonic Drive® component, the resolution of the output flange is 30 or 50 or 100 times the encoder revolution. Additionally, the incremental encoder signal is used in quadrature.

The following high resolutions are obtained:

Incremental encoder

Item	Model	FHA-8C FHA-11C FHA-14C		
		-30	-50	-100
Encoder resolution		2,000 (8,000 pulse/rev: quadruplicate)		
Reduction ratio		30	50	100
Detector resolution (quadruplicate)	Pulse/rev	240,000	400,000	800,000
Resolvable angle per pulse (approximate value)	Sec.	5.40	3.24	1.62

Absolute encoder

Item	Model	FHA-8C FHA-11C FHA-14C		
		-30	-50	-100
Encoder resolution		2 ¹⁷ (131,072 pulse/rev)		
Reduction ratio		30	50	100
Detector resolution (quadruplicate)	Pulse/rev	3,932,160	6,553,600	13,107,200
Resolvable angle per pulse (approximate value)	Sec.	Approx. 0.33	Approx. 0.2	Approx. 0.1

1-9 Torsional Stiffness of actuators

1-9-1 Moment stiffness

The moment stiffness refers to the torsional stiffness when a moment load is applied to the output flange of the actuator (shown in the figure to the right).

For example, when a load is applied to the end of an arm attached on the output flange, the face of the output flange tilts in proportion to the moment load. The moment stiffness is expressed as the torsional moment/angle.

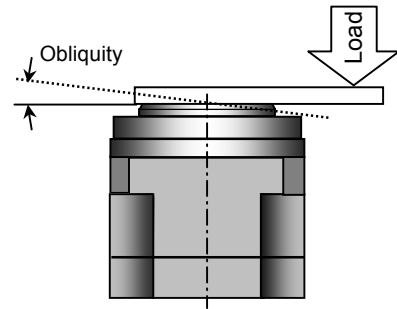

Model		FHA-8C	FHA-11C	FHA-14C
Item	N·m/rad	2×10^4	4×10^4	8×10^4
	kgf·m/rad	0.2×10^4	0.4×10^4	0.8×10^4
	kgf·m/arc min	0.59	1.2	2.4



Do not apply torque, load or thrust to the sleeve directly.

Since the sleeve is adhered to the output flange, the adhered sleeve may be detached from the output flange by the abnormal torque or load.

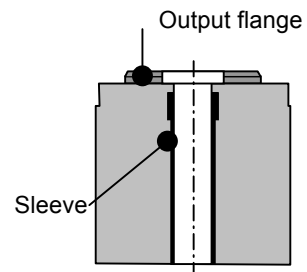

1-9-2 Torsional stiffness

When a torque is applied to the output flange of the actuator with the motor locked, the resulting torsional wind up is near proportional to the torque.

The upper right figure shows the torsional stiffness characteristics of the output flange applying torque starting from zero to plus side [+T₀] and minus side [-T₀]. This trajectory is called torque-torsion characteristics which typically follows a loop 0→A→B→A'→B'→A as illustrated. The torsional stiffness of the FHA-C mini actuator is expressed by the slope of the curve that is a spring rate (wind-up) (unit:N·m/rad).

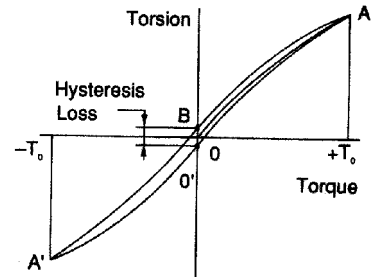

The torsional stiffness may be evaluated by dividing torque-torsion characteristics curve into three major regions. The spring rate of each region is expressed K₁, K₂, and K₃ respectively.

- K₁: spring rate for torque region 0-T₁
- K₂: spring rate for torque region T₁-T₂
- K₃: spring rate for torque region over T₂

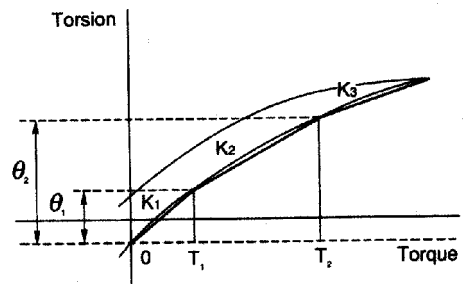

The wind-up for each region is expressed as follows:

- ◆ wind-up for torque region 0-T₁: $\varphi = \frac{T}{K_1}$
- ◆ wind-up for torque region T₁-T₂: $\varphi = \theta_1 + \frac{T - T_1}{K_2}$
- ◆ wind-up for torque region over T₂: $\varphi = \theta_2 + \frac{T - T_2}{K_3}$

※ φ : Wind - up

The table below shows T₁-T₃, K₁-K₃,and θ_1 - θ_2 values of each actuator.

Model		FHA-8C			FHA-11C			FHA-14C		
Reduction ratio		1:30	1:50	1:100	1:30	1:50	1:100	1:30	1:50	1:100
T ₁	N·m	0.29	0.29	0.29	0.80	0.80	0.80	2.0	2.0	2.0
	kgf·m	0.030	0.030	0.030	0.082	0.082	0.082	0.20	0.20	0.2
K ₁	x10 ⁴ N·m/rad	0.034	0.044	0.091	0.084	0.22	0.27	0.19	0.34	0.47
	kgf·m/arc min	0.010	0.013	0.027	0.025	0.066	0.080	0.056	0.10	0.14
θ_1	x10 ⁻⁴ rad	8.5	6.6	3.2	9.5	3.6	3.0	10.5	5.8	4.1
	arc min	3.0	2.3	1.1	3.3	1.2	1.0	3.6	2.0	1.4
T ₂	N·m	0.75	0.75	0.75	2.0	2.0	2.0	6.9	6.9	6.9
	kgf·m	0.077	0.077	0.077	0.20	0.20	0.20	0.70	0.70	0.7
K ₂	x10 ⁴ N·m/rad	0.044	0.067	0.10	0.13	0.30	0.34	0.24	0.47	0.61
	kgf·m/arc min	0.013	0.020	0.031	0.037	0.090	0.10	0.07	0.14	0.18
θ_2	x10 ⁻⁴ rad	19	13	8	19	8	6	31	16	12
	arc min	6.6	4.7	2.6	6.5	2.6	2.2	10.7	5.6	4.2
K ₃	x10 ⁴ N·m/rad	0.054	0.084	0.12	0.16	0.32	0.44	0.34	0.57	0.71
	kgf·m/arc min	0.016	0.025	0.036	0.047	0.096	0.13	0.10	0.17	0.21

The table below shows torque-wind-up relation for reference.

(unit: N·m)

Model		FHA-8C			FHA-11C			FHA-14C		
Reduction ratio		1:30	1:50	1:100	1:30	1:50	1:100	1:30	1:50	1:100
2		0.20	0.25	0.56	0.49	1.3	1.8	1.1	2.0	3.0
4		0.42	0.63	1.2	1.1	3.3	4.2	2.3	4.7	6.5
6		0.68	1.1	1.9	1.8	5.2	6.8	3.6	7.6	11

1-10 Rotary direction

Forward rotary direction is defined as clockwise (CW) rotation viewing the output flange of the actuator when a driver signals forward commands.

The direction can be reversed by the setting of [parameter mode] →[8: rotary direction] of the driver.

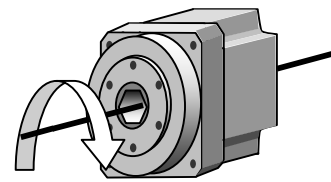

FWD : CW rotation

Value	FWD command	REV command	Setting
0	FWD rotation	REV rotation	Default
1	REV rotation	FWD rotation	

1-11 Impact resistance

The actuators are resistant to impacts along the radial axes.

Impact acceleration: 294 m/s^2

Direction: top/bottom, right/left, front/back

Repeating times: three

However, do not apply impact to the output flange.

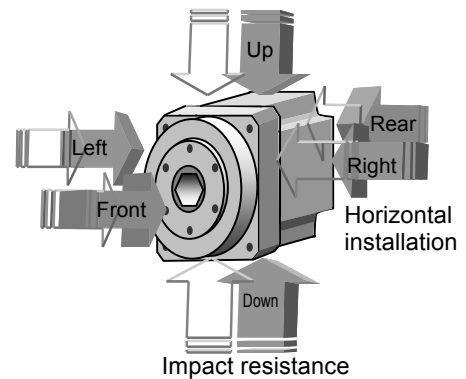

1-12 Vibration resistance

The allowable vibration from all directions is as follows:

Vibration acceleration: 24.5 m/s^2
(Frequency: 10~400Hz)

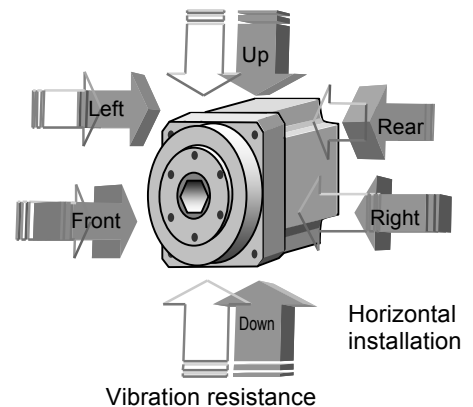

1-13 Torque-speed characteristics

The following are actuator speed-torque characteristics in combination with an HA-800 and HA-680 driver showing allowable duty range. Refer chapter 2 [selection guidelines] for more details.

◆ Continuous duty range

The range allows continuous operation for the actuator.



◆ 50% duty range

The range allows the 50% duty time operation of a cycle time. Refer section 2-4-5 [duty cycle].

◆ Acceleration and deceleration range

The range allows instantaneous operation like acceleration and deceleration, usually.

The continuous and 50% ranges in each graph are measured on the condition of the FHA-C mini actuator attached on the heat radiation plate described in the figure.

1-14 Operating Range

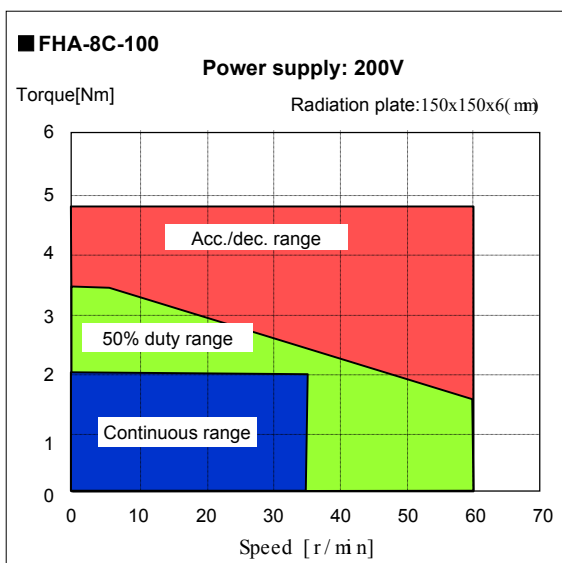
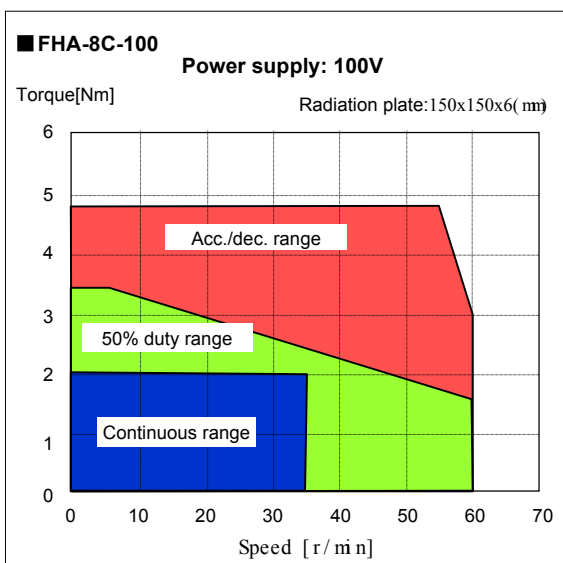
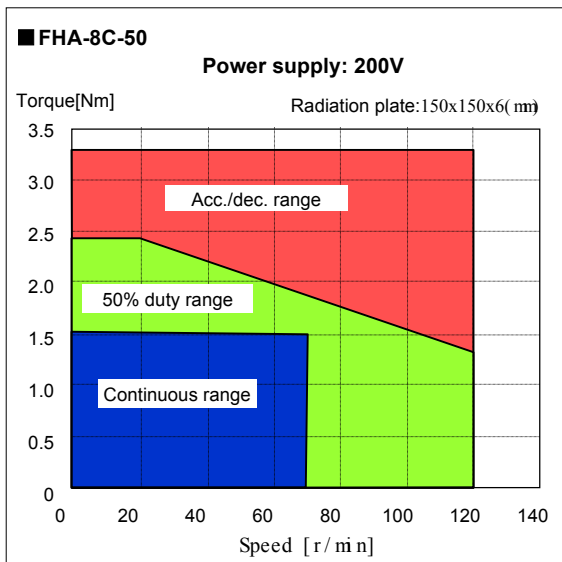
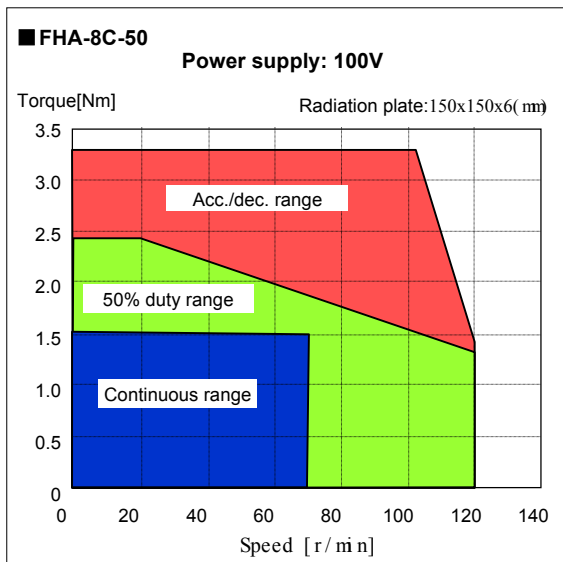
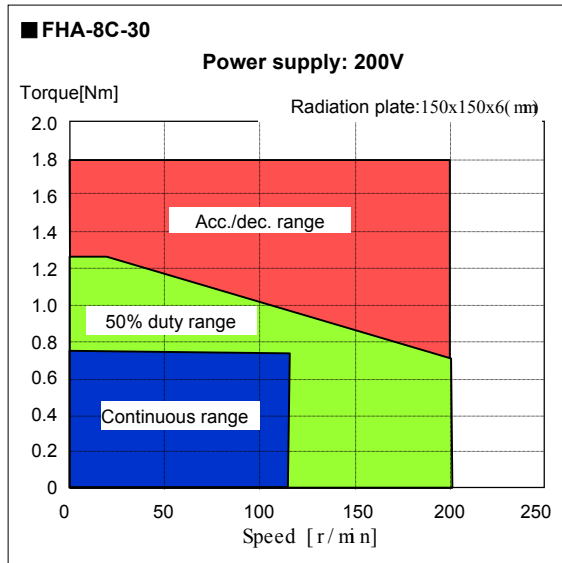
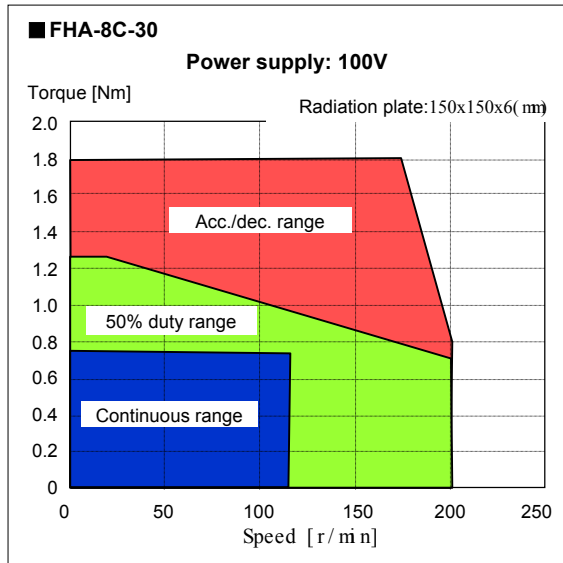

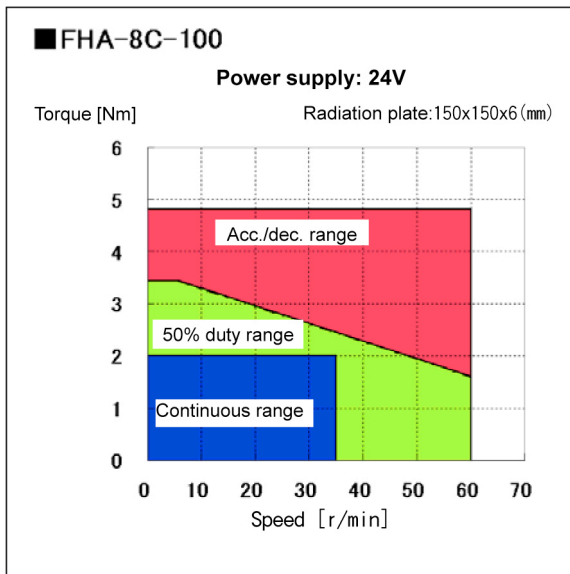
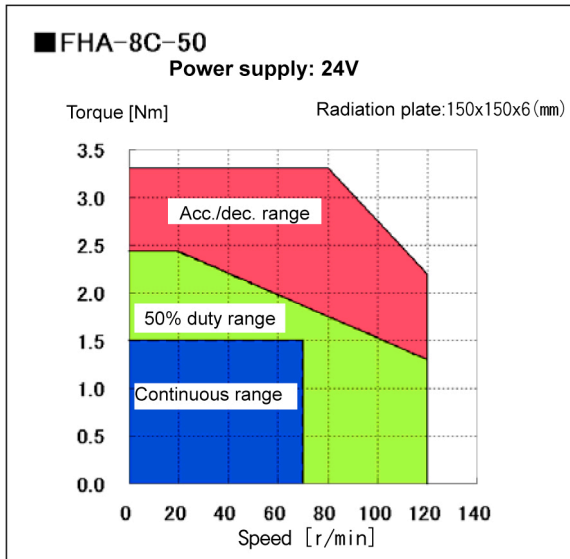
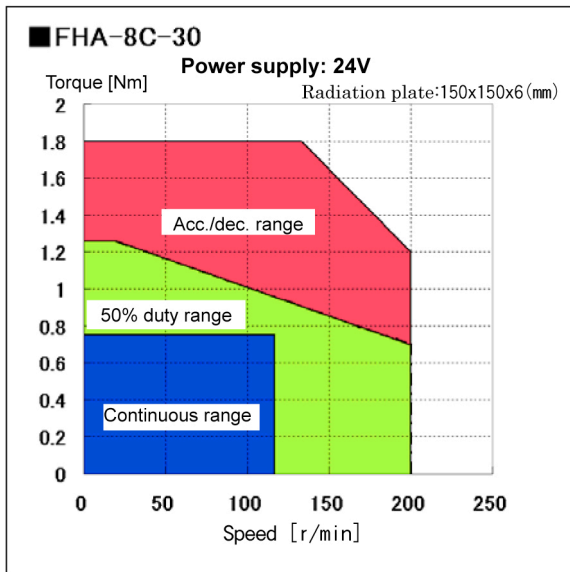

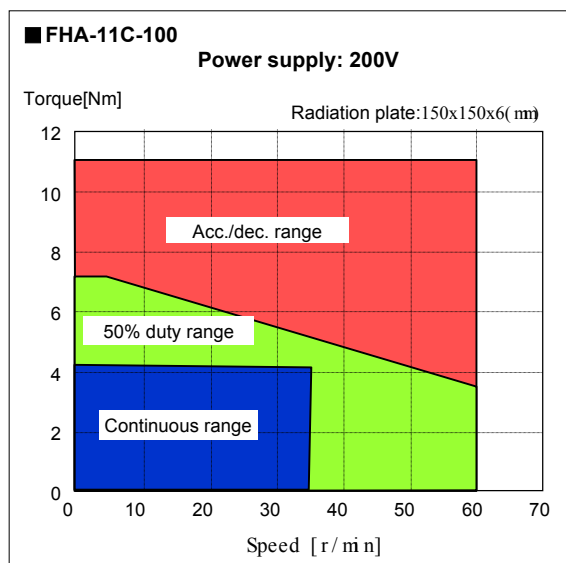
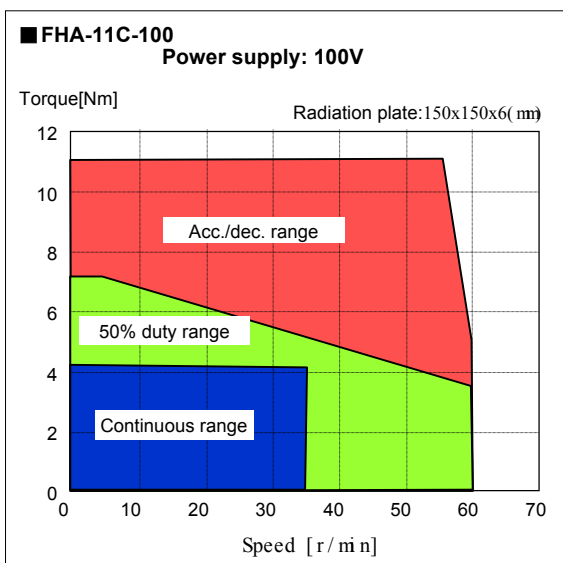
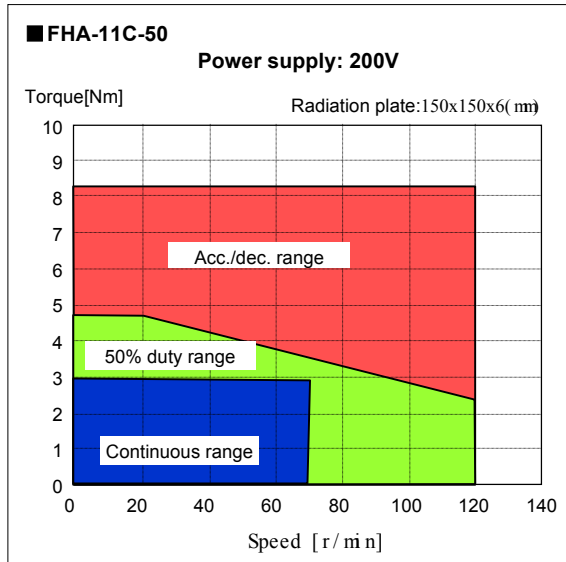
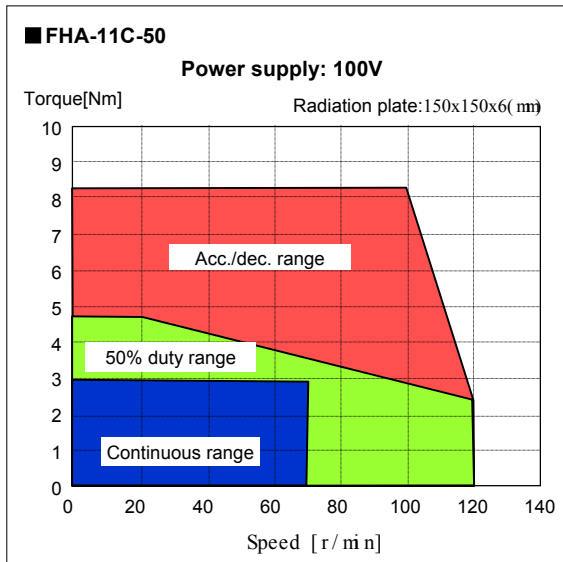
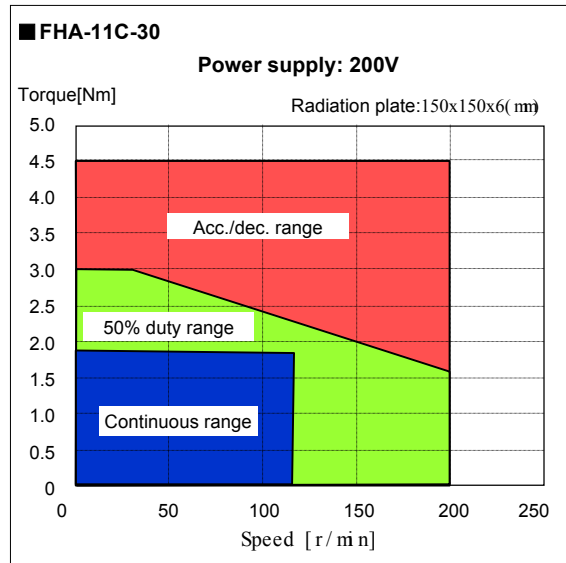
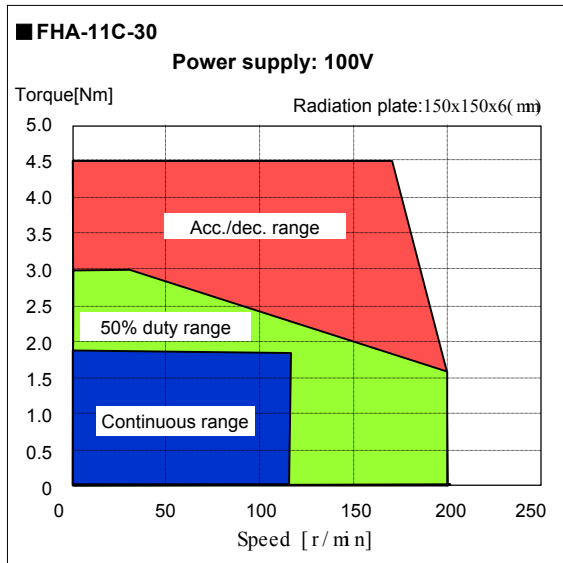

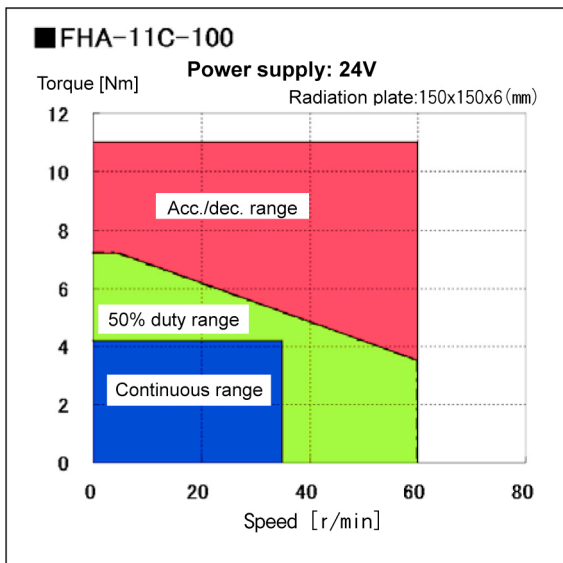
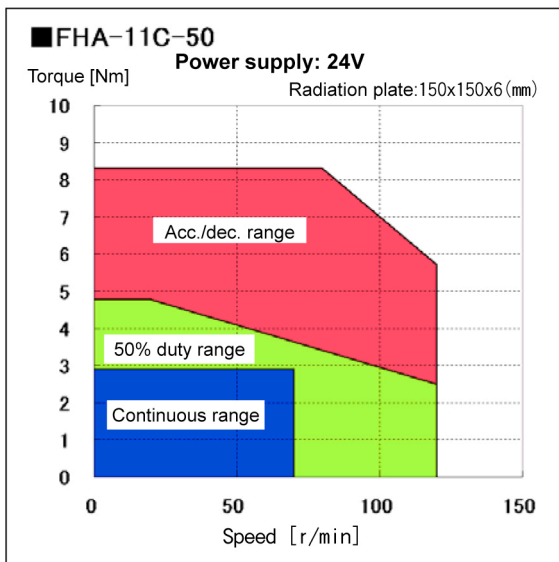
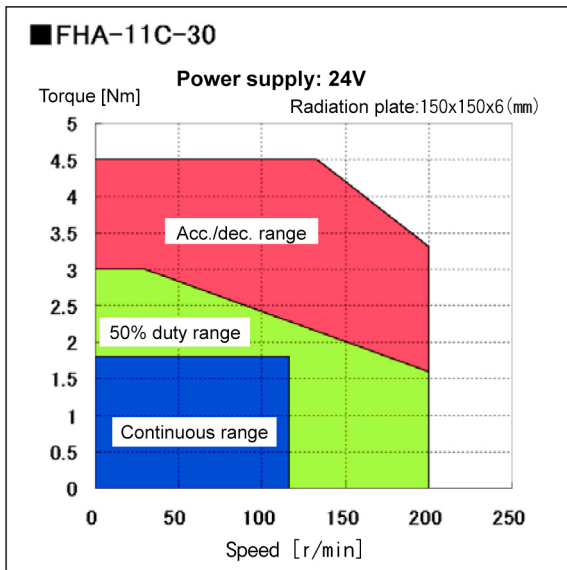

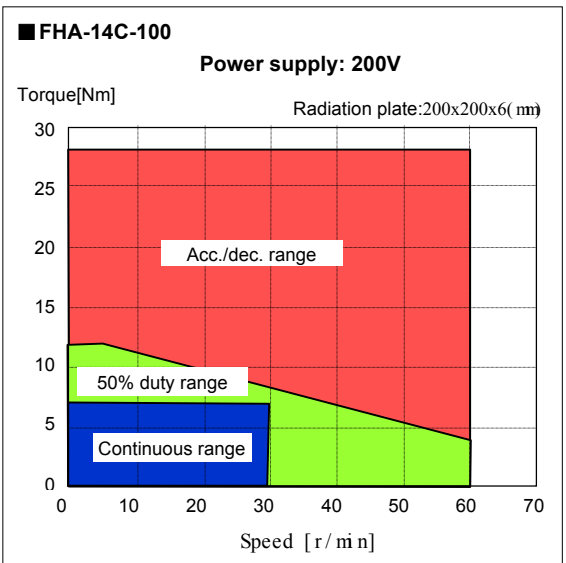
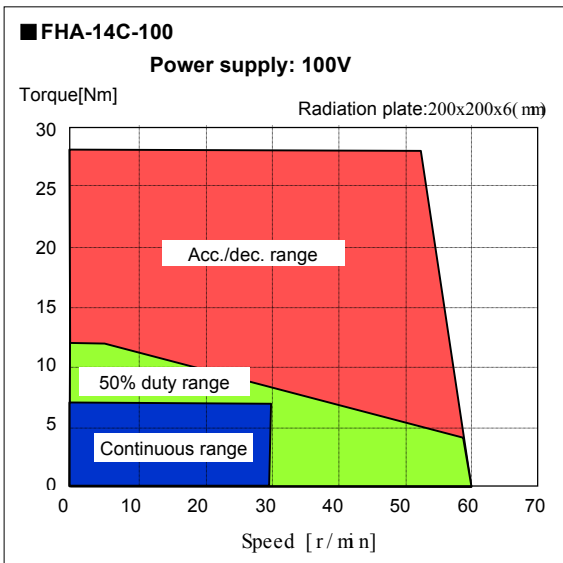
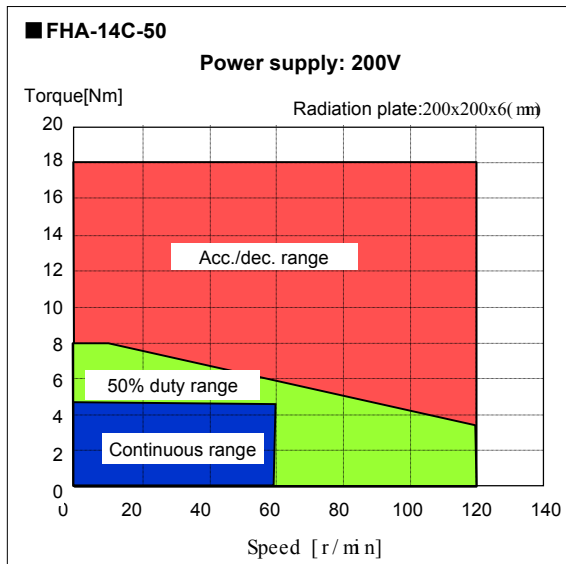
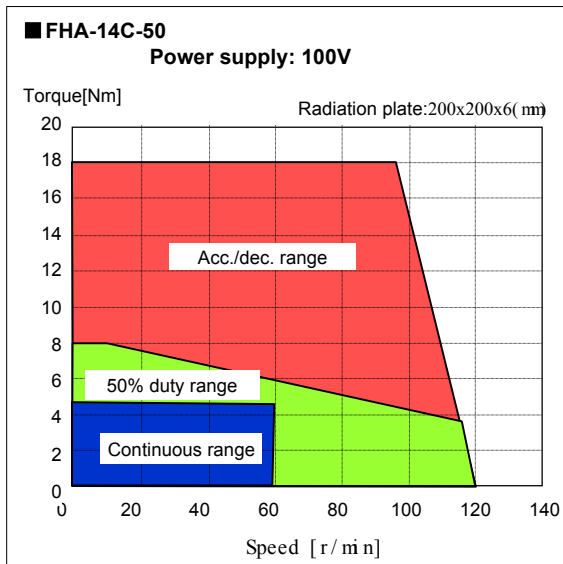
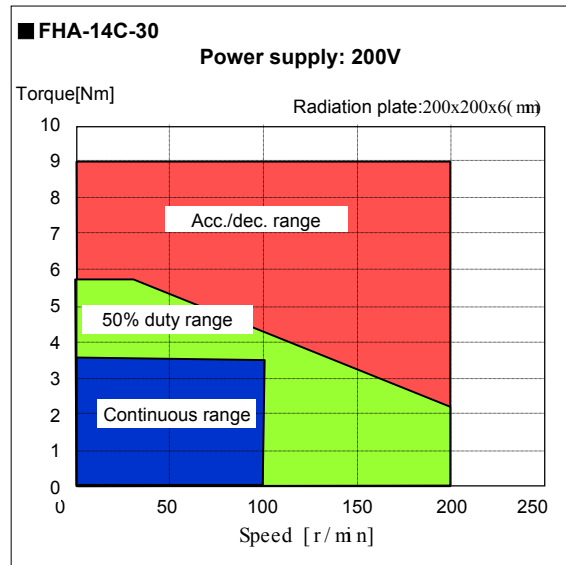
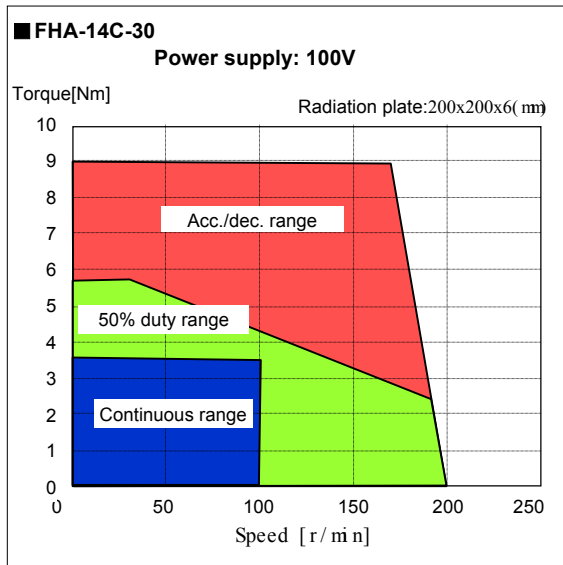

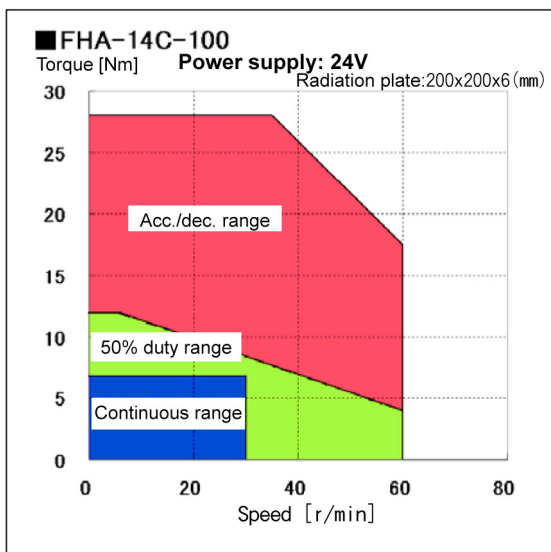
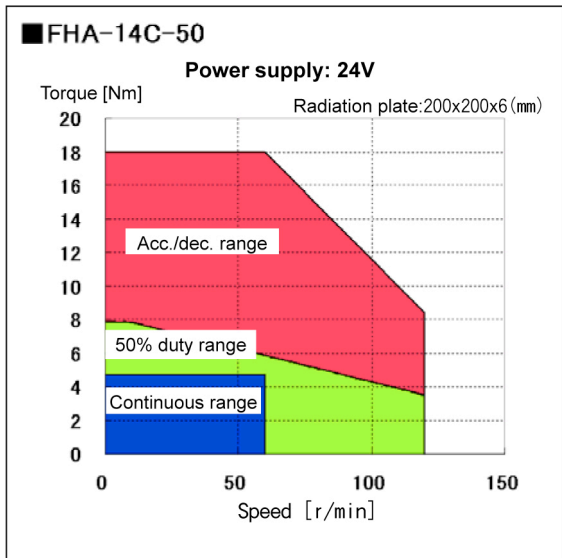
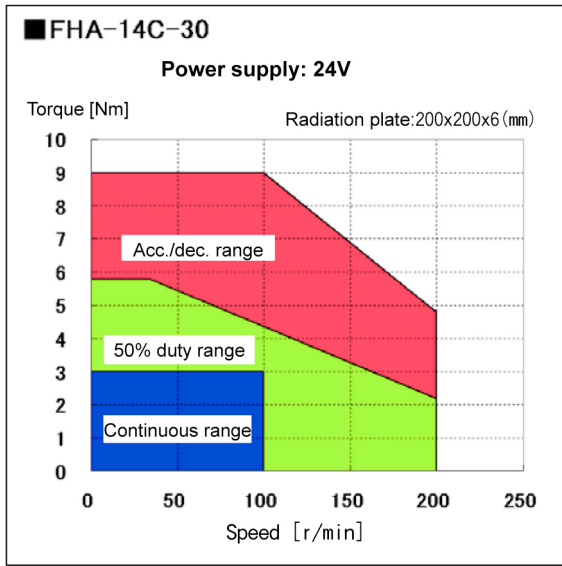

1-15 Cable specifications

The following tables show specifications of the cable for the motor and the encoder of the FHA-C mini actuators.

1-15-1 Incremental Encoder

◆ Motor cable

Color	Motor lead
Red	Motor phase-U
White	Motor phase-V
Black	Motor phase-W
Green/yellow	PE

◆ Encoder cable

Color	Signal	Color	Signal	Function
Red	+5V (VCC)	Black	OV (GND)	Power
Green	A	Dark Green	\overline{A}	Encoder Feedback
Gray	B	White	\overline{B}	
Yellow	Z	Clear	\overline{Z}	
Brown	U	Purple	\overline{U}	Motor Commutation
Blue	V	Light Blue	\overline{V}	
Orange	W	Pink	\overline{W}	

1-15-2 Absolute Encoder

◆ Motor cable (US 200)

Pin No.	Color	Motor lead
1	Red	Motor phase-U
2	White	Motor phase-V
3	Black	Motor phase-W
4	Green/yellow	PE
5	-	-
6	-	-

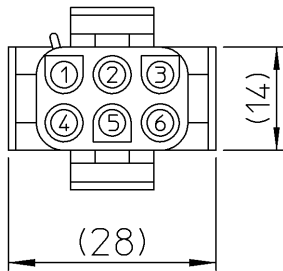

Connector pin layout

Connector model: 350715-1

Pin model: 3506901 (E: 770210-1)

Manufactured by AMP

◆ Encoder cable (US 200)

Pin No.	Color	Signal	Remarks
1A	White	Vcc	Power supply input +5V
1B	Black	GND (Vcc)	Power supply input 0V (GND)
2A	Blue	SD+	Serial signal differential output (+)
2B	Purple	SD-	Serial signal differential output (-)
3A	-	No connection	-
3B	Shield	FG	Frame Ground
4A	Orange	Vbat	Battery +
4B	Brown	GND (bat)	Battery - (GND)

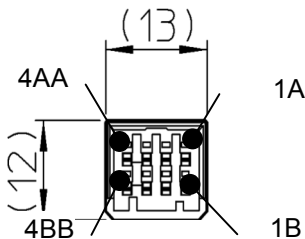

Connector pin layout

Connector model: 1-1903130-4

Pin model: 1903116-2 or 1903117-2

Manufactured by AMP

Chapter 2 Guidelines for sizing

2-1 Allowable load inertia

To achieve high accuracy performance, select an FHA-C mini actuator wherein the allowable moment of inertia (reference value) is greater than the load inertia.

Refer to appendix 1 for the calculation of moment inertia.

When selecting an actuator make certain that the load inertia and the nominal speed are less than the allowable values are that indicated in the table below.

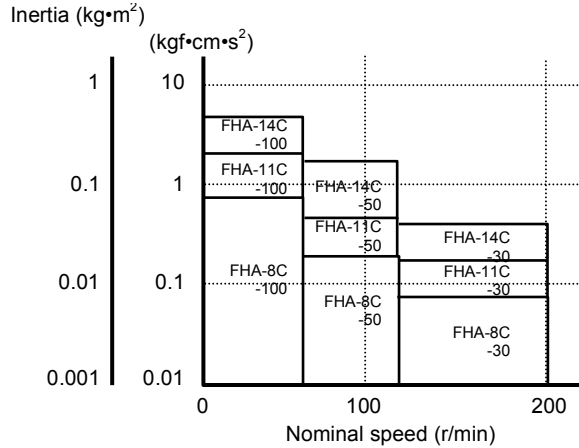

Actuator model		FHA-8C			FHA-11C			FHA-14C		
		-30	-50	-100	-30	-50	-100	-30	-50	-100
Reduction ratio		1:30	1:50	1:100	1:30	1:50	1:100	1:30	1:50	1:100
Maximum speed	r/min	200	120	60	200	120	60	200	120	60
Moment of inertia of actuator	kg·m ²	0.0026	0.0074	0.029	0.0060	0.017	0.067	0.018	0.050	0.20
	kgf·cm·s ²	0.027	0.075	0.30	0.061	0.17	0.68	0.18	0.51	2.0
Allowable moment of inertia	kg·m ²	0.0078	0.022	0.087	0.018	0.051	0.20	0.054	0.15	0.60
	kgf·cm·s ²	0.081	0.23	0.90	0.18	0.51	2.0	0.54	1.5	6.0

2-2 Variable load inertia

FHA-C mini series actuators include Harmonic Drive® gearing that has a high reduction ratio. Because of this there are minimal effects of variable load inertias to the servo drive system. In comparison to direct servo systems this benefit will drive the load with a better servo response.

For example, assume that the load inertia increases to N-times during its motion (for example, robot arms). The effect of the variable load inertia to the [total inertia converted into motor shaft] is as follows:

The symbols in the formulas are:

J_s : total inertia converted into motor shaft

L: Ratio of load inertia to motor inertia

J_M : moment inertia of motor

N: variation ratio of load inertia

R: reduction ratio of FHA actuator

•Direct drive

Before: $J_s = J_M(1+L)$

After: $J_s' = J_M(1+NL)$

Ratio: $J_s'/J_s = \frac{1+NL}{1+L}$

•FHA-C mini actuator drive

Before: $J_s = J_M \left(1 + \frac{L}{R^2} \right)$

After: $J_s' = J_M \left(1 + \frac{NL}{R^2} \right)$

Ratio: $J_s'/J_s = \frac{1+NL/R^2}{1+L/R^2}$

In the case of the FHA-C mini actuator drive, as the reduction ratio is [R=30], [R=50], or [R=100] and the square of the reduction ratio [R²=900], [R²=2500], or [R²=10000] the denominator and the numerator of the ratio are almost [1]. Then the ratio is [F=1]. This means that FHA drive systems are hardly affected by the load inertia variation. Therefore, it is not necessary to take the load inertia variation in consideration for selecting an FHA-C mini actuator or for setting up the HA-800 or HA-680 driver.

2-3 Verifying loads

The FHA-C mini actuators include a precise cross roller bearing for directly supporting the load weight. For optimal performance, verify that the maximum load weight is less than the allowable load and life and static safety coefficient of the cross roller bearing.

• Verifying procedures:

(1) Verifying the maximum load

Calculate the maximum load (M_{max} , F_{rmax} , F_{amax}).



Verify the maximum loads (M_{max} , F_{rmax} , F_{amax}) are less than (\leq) allowable loads (M_c , F_r , F_a)

(2) Verifying the life of the cross roller bearing

Calculate the average radial load (F_{rav}) and the average axial load (F_{aav}).



Calculate the radial load coefficient (X) and the axial load coefficient (Y).



Calculate the life of the bearing and verify the life is allowable.

(3) Verifying the static safety coefficient

Calculate the static equivalent radial load (P_o)



Verify the static safety coefficient.

• Specifications of the cross roller bearing

The following table shows the specifications of the cross roller bearings built in FHA-C mini actuators.

Table 1: Specifications of the cross roller bearings

Item Model	Circular pitch of roller (dp)	Offset (R)	Basic dynamic load rating (C)	Basic static load rating (Co)	Allowable axial load (Fa)	Allowable torsional moment (Mc)
	mm	mm	N	N	N	N·m
FHA-8C	35	12.9	5800	8000	200	15
FHA-11C	42.5	14	6500	9900	300	40
FHA-14C	54	14	7400	12800	500	75

• Calculating the maximum load

Calculate the maximum load (M_{max} , F_{rmax} , F_{amax}) with the following formula and verify that they are less than their allowances.

$$M_{max} = F_{rmax}(L_r + R) + F_{amax} \cdot L_a \quad (1)$$

Where, the variables of the formula are:

M_{max} : Maximum torsional moment in N·m(kgf·m)

F_{rmax} : Maximum radial load in N(kgf); See Fig.1.

F_{amax} : Maximum axial load in N(kgf); See Fig.1.

L_r , L_a : Loading point in mm; See Fig.1.

R : Offset: See Fig.1 and Table 1.

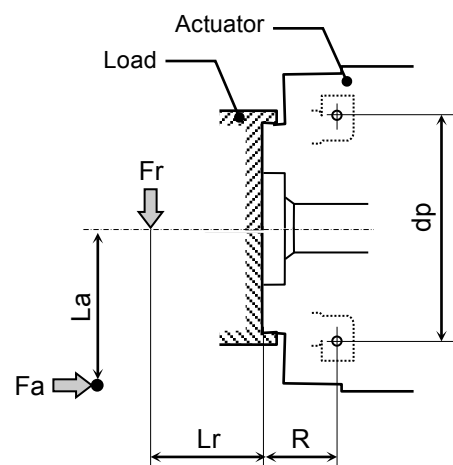

Fig.1 Loads

• **Calculating average loads:** average radial and axial loads, average output speed

When the radial and/or axial loads vary during motion, calculate and verify the life of the cross roller bearing converting the loads to their average values.

• **Average radial load: Frav**

$$Fr_{av} = \sqrt[10/3]{\frac{n_1 t_1 |Fr_1|^{10/3} + n_2 t_2 |Fr_2|^{10/3} + L |Fr_n|^{10/3}}{n_1 t_1 + n_2 t_2 + L + n_n t_n}} \quad (2)$$

Note: "Fr₁" is the maximum radial load in "t₁" range, and "Fr₃" is the maximum radial load in "t₃" range.

• **Average axial load: Faav**

$$Fa_{av} = \sqrt[10/3]{\frac{n_1 t_1 |Fa_1|^{10/3} + n_2 t_2 |Fa_2|^{10/3} + L |Fa_n|^{10/3}}{n_1 t_1 + n_2 t_2 + L + n_n t_n}} \quad (3)$$

Note: "Fa₁" is the maximum radial load in "t₁" range, and "Fa₃" is the maximum radial load in "t₃" range.

• **Average output speed: Nav**

$$Nav = \frac{n_1 t_1 + n_2 t_2 + L + n_n t_n}{t_1 + t_2 + L + t_n} \quad (4)$$

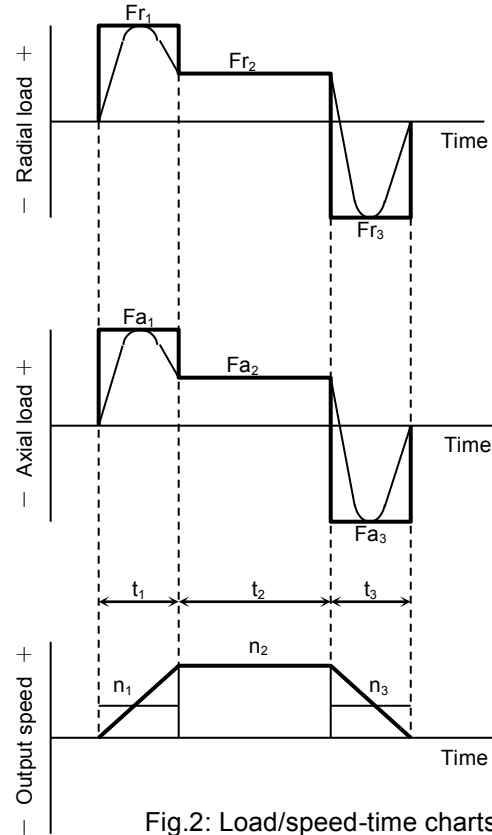

Fig.2: Load/speed-time charts

• **Calculating radial load factor and axial load factor**

Both load factors are different with average loads as follows:

• When the right formula is satisfied, $\frac{Fa_{av}}{Fr_{av} + 2(Fr_{av}(Lr + R) + Fa_{av} \cdot La)/dp} \leq 1.5$ (5)
 X=1.0, and Y=0.45

• When the formula below is satisfied, $\frac{Fa_{av}}{Fr_{av} + 2(Fr_{av}(Lr + R) + Fa_{av} \cdot La)/dp} > 1.5$ (5')
 X=0.67, and Y=0.67

Where, the variables of the formulas are:

- Mmax: Maximum torsional moment in N•m(kgf•m); obtained by the formula (1).
- Frmax: Maximum radial load in N(kgf); See Fig.1.
- Famax: Maximum axial load in N(kgf); See Fig.1.
- Lr, La: Loading point in mm; See Fig.1.
- R: Offset; See Fig.1 and Table 1.
- dp: Circular pitch of roller: See Fig.1 and Table 1.

• **Equivalent dynamic radial load**

The equivalent dynamic radial load is:

$$P_c = X \cdot \left(F_{rav} + \frac{2(F_{rav}(L_r + R) + F_{aav} \cdot L_a)}{dp} \right) + Y \cdot F_{aav} \tag{6}$$

Where, the variables of the formula are:

- F_{rav}: Average radial load in N(kgf); obtained by formula (2).
- F_{aav}: Average axial load in N(kgf); obtained by formula (3).
- dp: Circular pitch of roller: See Fig.1 and Table 1.
- X: Radial load factor; obtained by formula (5)
- Y: Axial load factor; obtained by formula (5')
- L_r, L_a: Loading point in mm; See Fig.1.
- R: Offset; See Fig.1 and Table 1.

• **Life of cross roller bearing**

Calculate the life of cross roller bearing with the formula below:

$$L_{B-10} = \frac{10^6}{60 \times N_{av}} \times \left(\frac{C}{f_w \cdot P_c} \right)^{10/3} \tag{7}$$

Where, the variables of the formula are:

- L_{B-10}: Life of cross roller bearing in hour
- N_{av}: Average output speed in r/min; obtained by formula (4).
- C: Basic dynamic load rating in N (kgf). See Table 1.
- P_c: equivalent dynamic radial load in N (kgf); obtained by formula (6).
- f_w: Load factor:
 - For smooth operation without shock or vibration: f_w=1 to 1.2
 - For normal operation: f_w=1.2 to 1.5
 - For operation with shock and/or vibration: f_w=1.5 to 3

• **Life of cross roller bearing for swaying motion**

Calculate the life of cross roller bearing with the formula below:

$$L_{oc} = \frac{10^6}{60 \times n_1} \times \frac{90}{\theta} \times \left(\frac{C}{f_w \cdot P_c} \right)^{10/3} \tag{8}$$

Where, the variables of the formula are:

- L_{oc}: Life of cross roller bearing in hour
- n₁: Average output speed in r/min; obtained by formula (4).
- C: Basic dynamic load rating in N (kgf). See Table 1.
- P_c: Equivalent dynamic radial load in N (kgf); obtained by formula (6).
- f_w: Load factor:
 - For smooth operation without shock or vibration: f_w=1 to 1.2
 - For normal operation: f_w=1.2 to 1.5
 - For operation with shock and/or vibration: f_w=1.5 to 3
- θ: Half of sway angle; See the right figure.

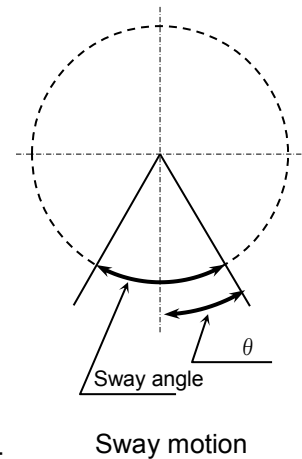

When the sway angle is less than 5 degrees, consult to Harmonic® drive systems, because fretting wear may occur for the operation caused by no oil film between the race and the rolling element.

• Equivalent static radial load

Equivalent static radial is obtained by formula (9) below.

$$P_o = F_{rmax} + \frac{2M_{max}}{d_p} + 0.44F_{amax} \quad (9)$$

Where, the variables of the formula are:

- P_o: Equivalent static radial load in N (kgf);
- M_{max}: Maximum torsional moment in N•m(kgf•m); obtained by the formula (1)
- F_{rmax}: Maximum radial load in N(kgf); See Fig.1.
- F_{amax}: Maximum axial load in N(kgf); See Fig.1.
- d_p: Circular pitch of roller: See Fig.1 and Table 1.

• Static safety factor

Generally, the static safety factor is limited by the basic static load rating (C_o). However, for the heavy duty, the factor is limited by the following formula:

$$f_s = \frac{C_o}{P_o} \quad (10)$$

Where, the variables of the formula are:

- f_s: Static safety factor;
 - For precise positioning operation: f_s ≥ 3
 - For operation with shock and/or vibration: f_s ≥ 2
 - For normal operation: f_s ≥ 1.5
- C_o: Basic static load rating in N (kgf). See Table 1.
- P_o: Equivalent static radial load in N (kgf); obtained by formula (9) below.

2-4 Duty cycles

When a duty cycle includes many frequent start and stop operations, the actuator generates heat by high starting and braking current. Therefore, it is necessary to study the duty cycle profile.

The study is as follows:

2-4-1 Actuator speed

Calculate the required actuator speed (r/min) to drive the load.

For linear motion, convert with the formula below:

$$\text{Rotary speed (r/min)} = \frac{\text{Linear speed (mm/min)}}{\text{Pitch of screw (mm)}}$$

Select a reduction ratio from [30], [50] and [100] of an actuator of which the maximum speed is more than the required speed.

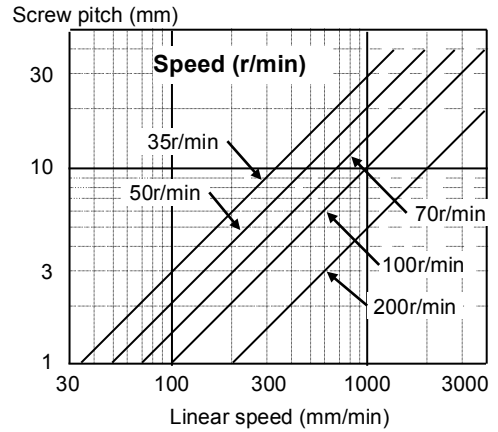

2-4-2 Load inertia

Calculate the load inertia driven by the FHA-C mini series actuator.

Refer to appendix 1 for the calculation.

Tentatively select an FHA-C mini actuator referring to section [2-1 allowable load inertia] with the calculated value.

2-4-3 Load torque

Calculate the load torque as follows:

• **Rotary motion**

The torque for the rotating mass [W] on the friction ring of radius [r] as shown in the figure to the right.

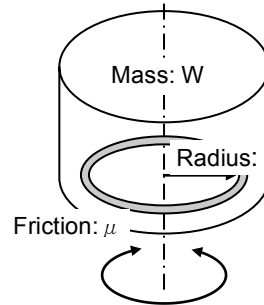

$$T = 9.8 \times \mu \times W \times r$$

T: torque (N·m)

μ: coefficient of friction

W: mass (kg)

r: radius of friction face (m)

Example. torque calculation (friction=0.1)
FHA(ratio:1/50): 20% torque of maximum torque

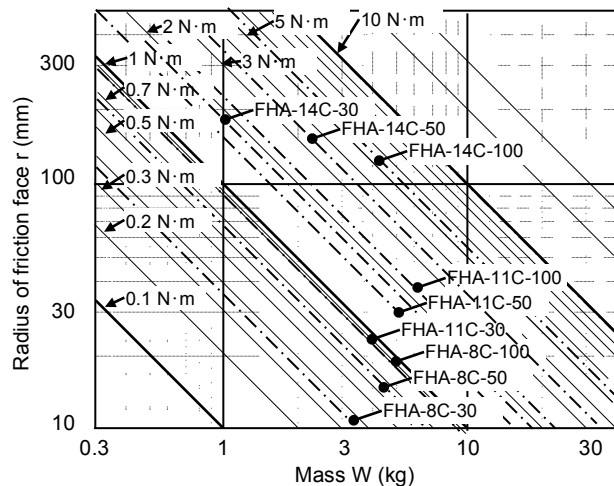

In the right graph, the oblique solid lines for torque have been calculated with the coefficient of the friction of $\mu=0.1$.

The oblique dot-chain lines show 20% torque of actuators converted from 300% torque corresponding to its maximum torque.

• **Horizontal linear motion**

The following formula calculates the torque for horizontal linear motion of mass [W] fed by the screw of pitch [P].

$$T = 9.8 \times \mu \times W \times \frac{P}{2 \times \pi}$$

- T: torque (N•m)
- μ: coefficient of friction
- W: mass (kg)
- P: screw pitch (m)

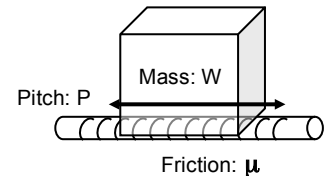

• **Vertical linear motion**

The following formula calculates the torque for vertical linear motion of mass [W] fed by the screw of pitch [P].

$$T = 9.8 \times W \times \frac{P}{2 \times \pi}$$

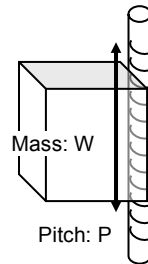

2-4-4 Acceleration time and deceleration time

Calculate acceleration and deceleration times for the selected actuator.

Acceleration: $t_a = (J_A + J_L) \times \frac{2 \times \pi}{60} \times \frac{N}{T_M - T_L}$

Deceleration: $t_d = (J_A + J_L) \times \frac{2 \times \pi}{60} \times \frac{N}{T_M + 2 \times T_F - T_L}$

- T_a: acceleration time (sec)
- T_d: deceleration time (sec)
- J_A: actuator inertia (kg•m²)
- J_L: load inertia (kg•m²)
- N: actuator speed (r/min)
- T_M: maximum torque of actuator (N•m)
- T_F: actuator friction torque at max. speed (N•m)
- $T_F = K_T \times I_M - T_M$
- where, K_T: torque constant (N•m/A)
- I_M: maximum current (A)
- T_L: load torque (N•m)

note that the polarity of the load torque is plus (+) for counter direction of revolution, and minus (-) for same direction.

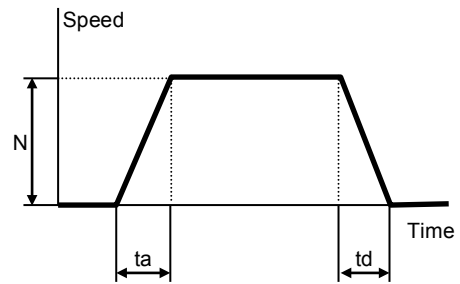

• **Example 1:**

The load conditions are: Rotary speed: 100r/min
 Moment of inertia: 0.04 kg•m²
 Load torque is so small as to be neglected.

- (1) Referring the figure in section 2-1, FHA-11C-50 actuator is selected for the load.
- (2) Referring the specification table in section 1-4, J_A=0.017 kg•m², T_M =8.3 N•m, K_T=6.6 N•m/A, and I_M =1.6A are obtained for the FHA-11C-50.
- (3) T_F = 6.6x1.6-8.3 = 2.3 N•m is obtained with the formula above.
- (4) Acceleration and deceleration times are:
 $t_a = (0.017+0.04) \times 2 \times \pi / 60 \times 100 / 8.3 = 0.072$ s
 $t_d = (0.017+0.04) \times 2 \times \pi / 60 \times 100 / (8.3+2 \times 2.3) = 0.046$ s
- (5) If the calculated acceleration times are too long, correct the situation by:
 Reducing load moment of inertia
 Selecting an actuator with a larger frame size

2-4-5 Calculating equivalent duty

The load conditions, which is torque, speed, moment of inertia, acceleration/deceleration time, loading time, are limited by the actuator to drive the load. To select the proper actuator, the equivalent duty of the load should be calculated.

The %ED (percent equivalent duty) is:

$$\%ED = \frac{K_{La} \times t_a + K_{Lr} \times t_r + K_{Ld} \times t_d}{t} \times 100$$

- where, t_a : acceleration time in second
- t_d : deceleration time in second
- t_r : driving time in second
- t : single cycle time in second
- K_{La} : duty factor for acceleration time
- K_{Lr} : duty factor for driving time
- K_{Ld} : duty factor for deceleration time

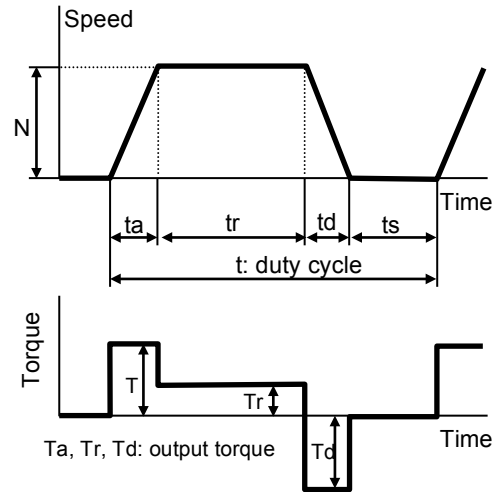

• Example 2: getting duty factors of K_{La} , K_{Lr} and K_{Ld}

With an example of the duty factor graph for FHA-11C-50 actuator, the way of getting the duty factors of K_{La} , K_{Lr} and K_{Ld} is described as follow:

The load conditions are same as the example described in the example1: the inertia load is accelerated by the maximum torque, and is driven with a constant speed, and is decelerated by the maximum torque. The displacement angle is 120 degrees and the cycle time is 0.8 s.

- (1) K_{La} , and K_{Ld} : the speed is decided at 50 r/min as the average of 0 and 100 r/min. Then, $K_{La} = K_{Ld} = 1.7$ from the graph.
- (2) K_{Lr} : as the inertia load, $T_r=0$. Then $K_{Lr} = 0.9$ from the graph.
- (3) The driving time is calculated as the area of the trapezoid of speed-time graph. Then the displacement angle is:

$$\theta = (N / 60) \times \{t_r + (t_a + t_d) / 2\} \times 360$$

$$\text{Then, } t_r = \theta / (6 \times N) - (t_a + t_d) / 2$$

Substituting 120 deg. for θ , 0.072(s) for t_a , 0.046(s) for t_d , 100r/min for N, the driving time is:

$$t_r = 120 / (6 \times 100) - (0.072 + 0.046) / 2 = 0.14(\text{s})$$

- (4) Because the cycle time is 0.8(s), the %ED is obtained as follows:

$$\%ED = (1.7 \times 0.072 + 0.9 \times 0.14 + 1.7 \times 0.046) / 0.8 \times 100 = 41.2\%$$

It is possible to drive the actuator with the load specifications continuously, because the %ED is less than 100%.

If the %ED is exceeded 100%, correct the situation by:

- Changing the speed-time profile
- Reducing load moment of inertia
- Selecting an actuator with a larger frame size

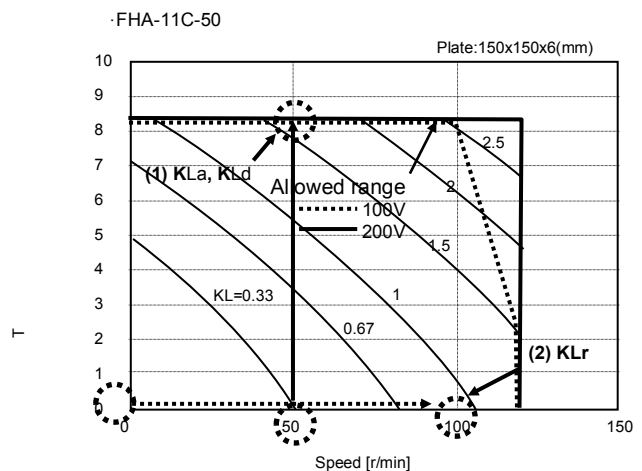

• Graphs of duty factor

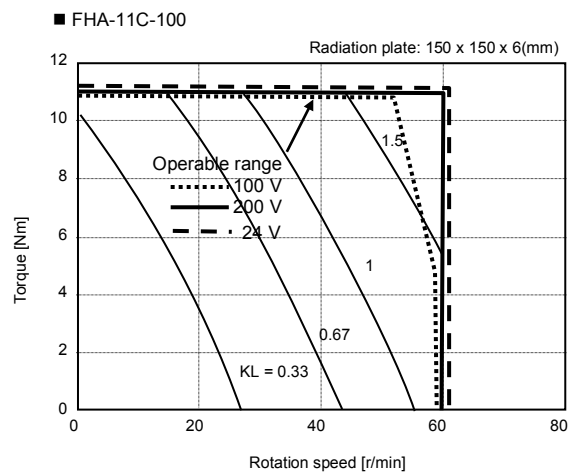
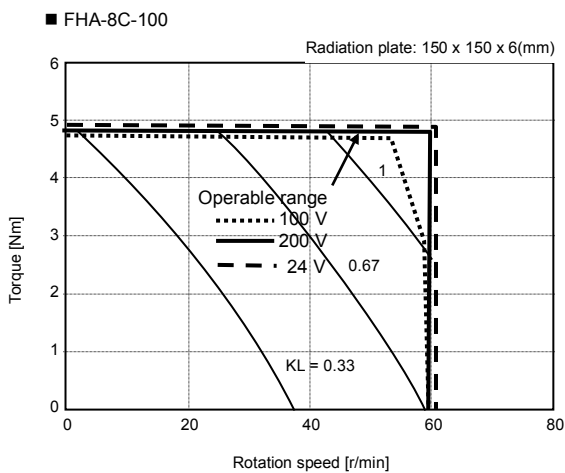
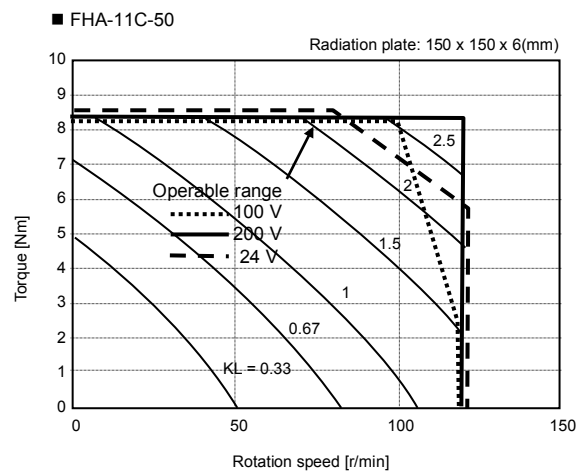
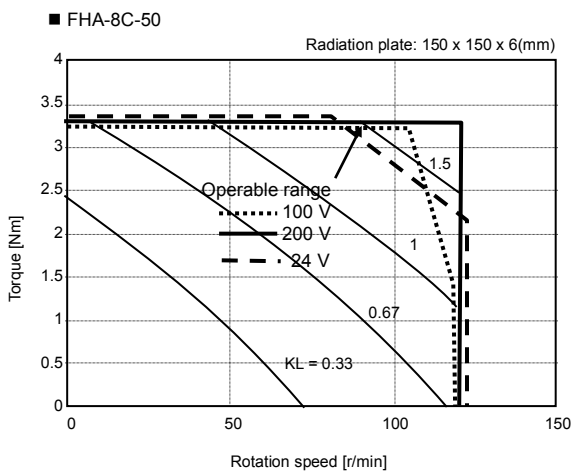
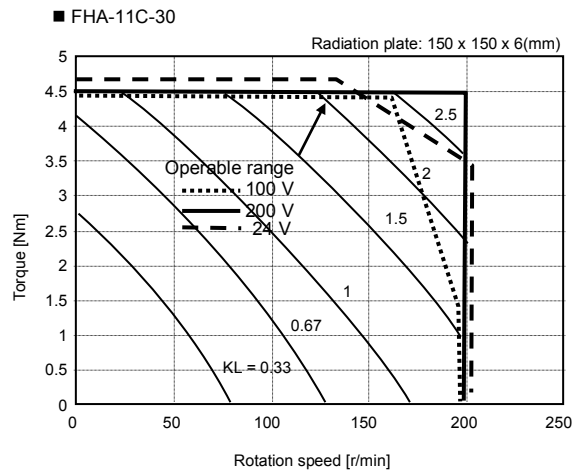
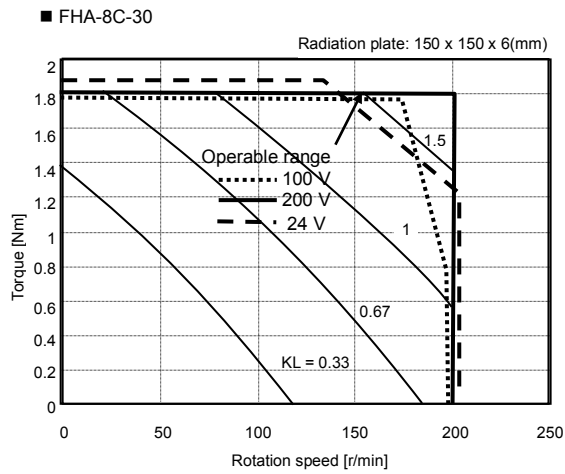

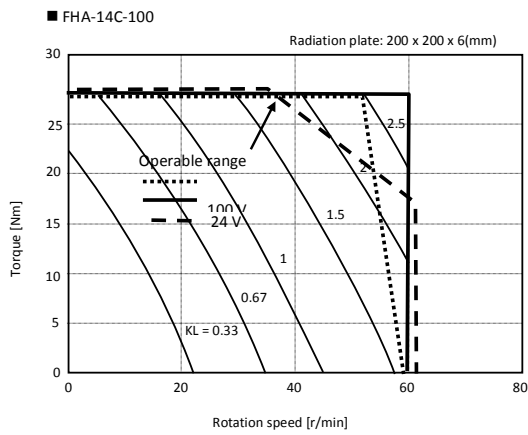
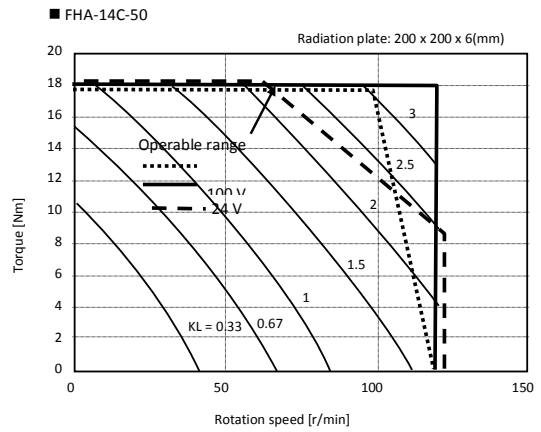
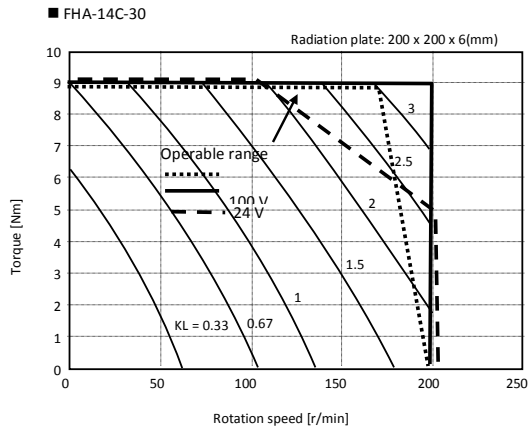

2-4-6 Effective torque and average speed

Effective torque and the average speed should also be reviewed.

- (1) The effective torque should be less than allowable continuous torque specified by the driver.
- (2) The average speed should be less than allowable continuous speed of the actuator.

Calculate the effective torque and the average speed of an operating cycle as shown in the former figure.

$$T_m = \sqrt{\frac{T_a^2 \times (t_a + t_d) + T_r^2 \times t_r}{t}}$$

$$N_{av} = \frac{N/2 \times t_a + N \times t_r + N/2 \times t_d}{t}$$

- T_m : effective torque (N·m)
- T_a : maximum torque (N·m)
- T_r : load torque (N·m)
- t_a : acceleration time (s)
- t_d : deceleration time (s)
- t_r : running time at constant speed (s)
- t : time for one duty cycle (s)
- N_{av} : average speed (r/min)
- N : driving speed (r/min)

If the result is greater than the value in the table below, calculate once again after reducing the duty cycle.

Model		FHA-8C			FHA-11C			FHA-14C		
		-30	-50	-100	-30	-50	-100	-30	-50	-100
Items										
Reduction ratio		1:30	1:50	1:100	1:30	1:50	1:100	1:30	1:50	1:100
Continuous torque	N·m	0.75	1.5	2	1.8	2.9	4.2	3.5 (3.0)	4.7	6.8
Continuous speed	r/min	117	70	35	117	70	35	100	60	30

Note: The values for 24VDC are in parenthesis.

· Example 3: getting effective torque and average speed

The parameters are same as the example 1 and 2 for an FHA-11C-50.

(1) Effective torque

From the parameters of $T_a = T_d = 8.3 \text{ N}\cdot\text{m}$, $T_r = 0 \text{ N}\cdot\text{m}$, $t_a = 0.072 \text{ s}$, $t_r = 0.14 \text{ s}$, $t_d = 0.046 \text{ s}$, $t = 0.8 \text{ s}$,

$$T_m = \sqrt{\frac{8.3^2 \times (0.072 + 0.046)}{0.8}} = 3.19 \text{ N}\cdot\text{m}$$

As the value of T_m ($3.21 \text{ N}\cdot\text{m}$) exceeds its allowable continuous torque ($2.9 \text{ N}\cdot\text{m}$), it is impossible to drive the actuator continuously on the duty cycle. The following equation is introduced by converting the equation for effective torque. The limited time for one duty cycle can be obtained by substituting the continuous torque for the T_m of the following equation.

$$t = \frac{T_a^2 \times (t_a + t_d) + T_r^2 \times t_r}{T_m^2}$$

Substituting $8.3 \text{ N}\cdot\text{m}$ for T_a , 8.3 for T_d , $0 \text{ N}\cdot\text{m}$ for T_r , $2.9 \text{ N}\cdot\text{m}$ for T_m , 0.072 s for t_a , 0.14 s for t_r , and 0.046 s for t_d :

$$t = \frac{8.3^2 \times (0.072 + 0.046)}{2.9^2} = 0.97$$

Namely, when the time for one duty cycle is set more than 3.4 s , the effective torque [T_m] becomes less than $2.9 \text{ N}\cdot\text{m}$, and the actuator can drive the load with lower torque than the continuous torque continuously.

(2) Average speed

From the parameters of $N = 100 \text{ r/min}$, $t_a = 0.072 \text{ s}$, $t_r = 0.14 \text{ s}$, $t_d = 0.046 \text{ s}$, $t = 0.97 \text{ s}$

$$N_{av} = \frac{100 / 2 \times 0.072 + 100 \times 0.14 + 100 / 2 \times 0.046}{0.97} = 20.5 \text{ r/min}$$

As the speed is less than the continuous speed of FHA-11C-50, it is possible to drive it continuously on new duty cycle.

2-4-7 Permissible overloaded time

The overloaded time is limited by the protective function in the driver even if the duty cycle is allowed. The limits are shown in the figure below.

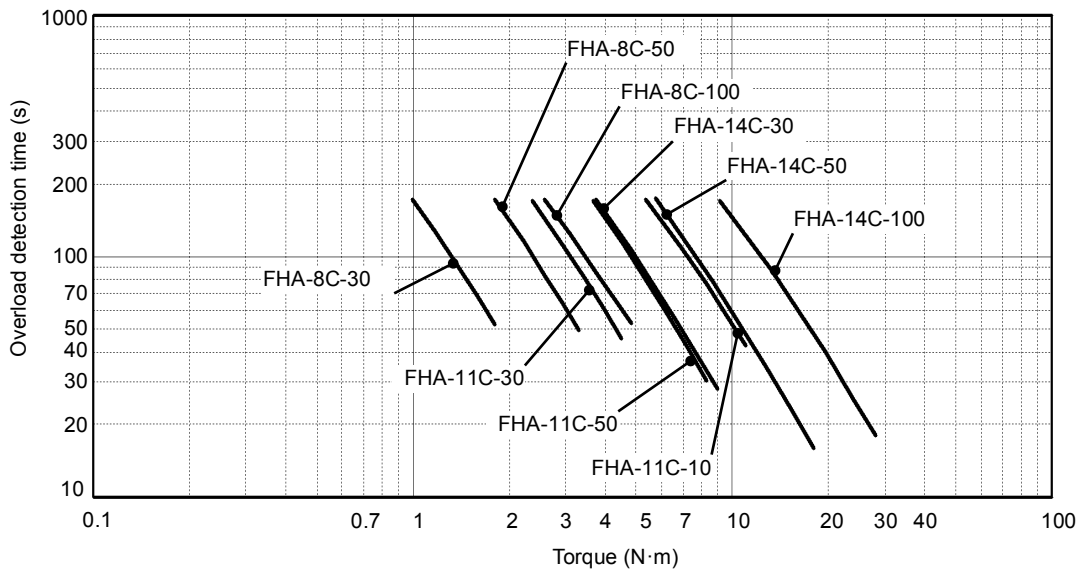
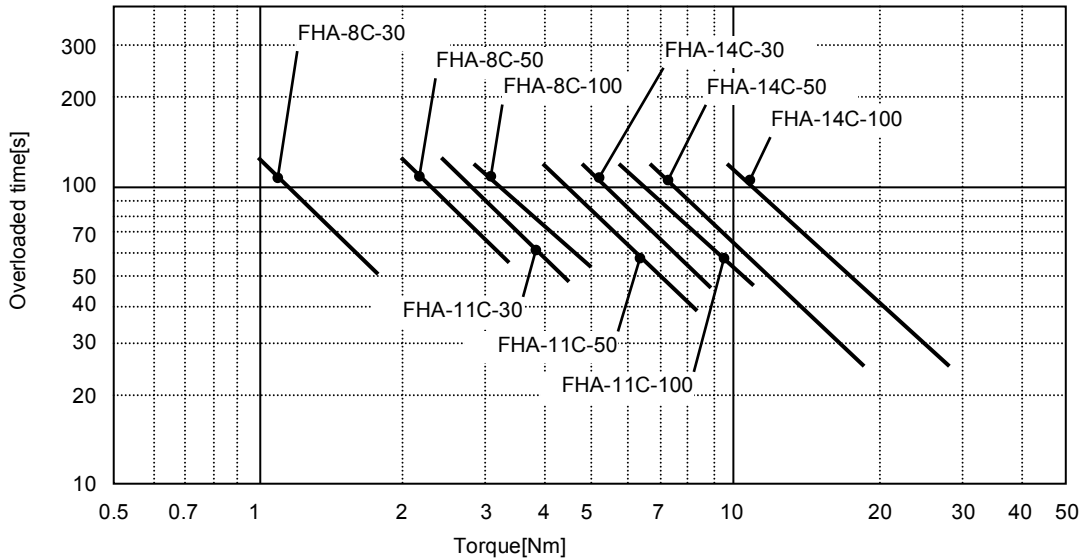

Chapter 3 Installing the FHA-C mini actuator

3-1 Receiving Inspection

Check the following when products are received.

•Inspection procedure

- (1) Check the shipping container and item for any damage that may have been caused during transportation. If the item is damaged, immediately report the damage to the dealer it was purchased from.
- (2) A label is attached on the right side of the FHA actuator. Confirm the products you ordered by comparing with the model on the [TYPE] line of the label. If it is different, immediately contact the dealer it was purchased from.

The model code is interpreted as follows:

Incremental Encoder

FHA-11 C-50 US 200 -□

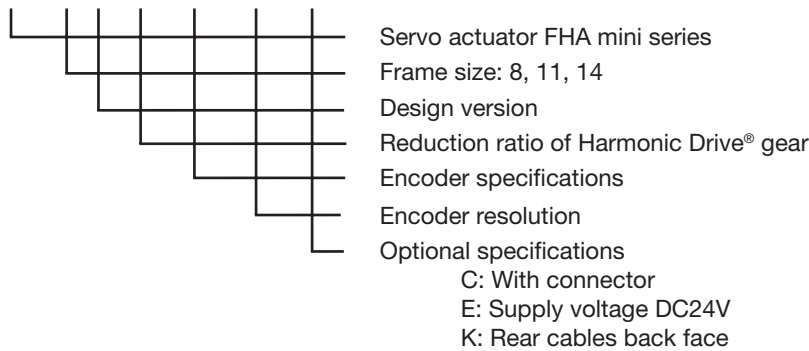

Absolute Encoder

FHA-8 C-50 -12S17b □-C

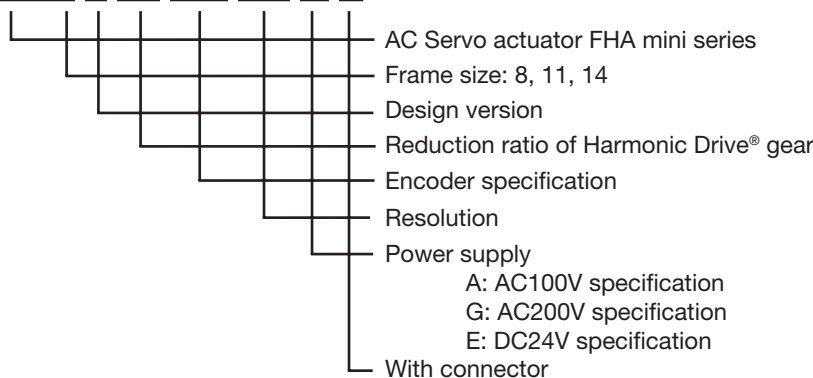

Refer to section 1-2 in this manual for the detail of the model codes.

The label on the HA-800 or HA-680 driver will indicate the appropriate FHA-C mini series model number on the [ADJUSTED FOR USE WITH] line. Make sure your actuator is combined with the correct driver.

(3)



Only connect the actuator specified on the driver label.

The drivers have been tuned for the actuator specified on the driver label. Wrong combination of drivers and FHA actuators may cause low torque problems or over current that may cause physical injury and fire.

- (4) A model of the driver is marked on the [TYPE] line of the label. The last three digits indicate the voltage of power supply.

200: 3-phase or single phase 200V

100: single phase 100V

24: 24VDC power

If the voltage to be supplied is different from the label voltage, contact us immediately.



Do not connect a supply voltage other than the voltage specified on the label.

The wrong power supply voltage may damage the driver resulting physical injury and fire.

3-2 Notice on handling

Handle FHA-C mini series actuators with care, specifically:



Do not plug the actuators directly into a commercial line power source.

This could burn out the actuator, potentially resulting in a fire and/or electrical hazard.



- (1) **Do not apply impact or unnecessary excessive force to output flange of actuators.**
- (2) **Do not put actuators on in a location where the driver could easily fall.**
- (3) **The allowable temperature for storage is from -20°C to $+60^{\circ}\text{C}$. Do not expose it to the sunlight for a long time and do not store it in areas with widely fluctuating temperatures.**
- (4) **The allowable relative humidity for storage is less than 80%. Do not storage it in highly humid place or in a place where temperature changes excessively during the course of a day.**
- (5) **Do not store units in locations with corrosive gas or particles.**

3-3 Location and installation

3-3-1 Environment of location

The environmental conditions of the location must be as follows.

- Service temperature: 0°C to 40°C

When the actuator is installed in a closed space, the temperature in the space may be higher than the atmosphere because of heat emission by the actuator. Design the closed space size, ventilation system, and device locations so the ambient temperature near the actuator is always less than 40°C .

- Service humidity: 20 to 80% relative humidity, without condensation

Make sure no water condensation occurs at the place where there is a large temperature change in a day or due to frequent heat-and-cool cycles due to the operation of the actuator.

- Vibration: less than $25\text{m}/\text{sec}^2$ (2.5G) (10Hz~400Hz)

- Impact: less than $300\text{m}/\text{sec}^2$ (30G)

- Make sure the actuator is in an area free from: dust, water condensation, metal powder, corrosive gas, water, water drops, and oil mist.

Do not install the actuator in corrosive gas environment.

Take notice that the protection degree of standard actuators is IP-44, that is, all parts of the actuators, except the rotary sliding parts (oil seal) and connectors, are protected against solid bodies of superior dimensions to 1 mm, and against the water sprays.

- Locate the driver indoors or within an enclosure. Do not expose it to the sunlight.

- Altitude: lower than 1000m above sea level

3-3-2 Installation

Since the FHA-C mini series actuator is a high precision servomechanism, great care is required for proper installation.

When installing the actuator, pay attention to the precision of the assembly. Do not hit the actuator with a hammer. Take note that actuators provide a glass encoder, which may be damaged by impact.

• **Procedure**

- (1) Align the axis of rotation of the actuator and the load mechanism precisely.

Note 1: Perform this alignment carefully, especially when a rigid coupling is used. Even slight misalignment may cause the permissible load of the actuator to be exceeded, resulting in damage to the output shaft.

Note 2: Do not apply shock or impact during installation.

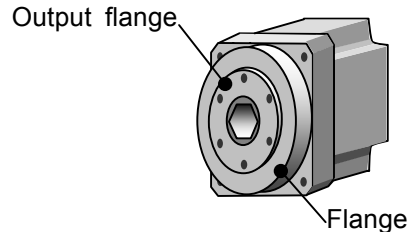

- (2) Fasten the flange of the actuator with flat washers and high strength bolts. Use a torque wrench when tightening the fasteners.

The recommended tightening torque is shown in the table below:

Item \ Model		FHA-8C		FHA-11C		FHA-14C	
		Output flange	Flange	Output flange	Flange	Output flange	Flange
Wrenching torque	Screw, hole depth	6-M3 depth: 5	4-M3	6-M4 depth: 5	4-M4	6-M5 depth: 7	4-M5
	N·m	2	1.2	4.5	2.7	9.0	5.4
	kgf·cm	20	12	46	28	92	55

- (3) Refer to the driver manual for cable installation.

- (4) Motor cable and encoder cable

Do not pull the cable with strong force, which may damage the connection. Install the cable with slack not to apply tension to the actuator. Keep the minimum bending radius more than 40mm, when the cable will be bent and stretched.

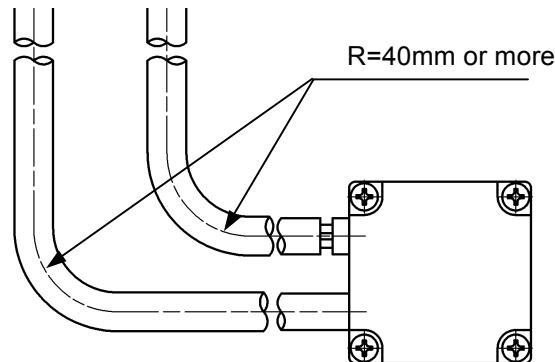



CAUTION

Do not apply torque, load or thrust to the sleeve directly.

Since the sleeve is adhered to the output flange, the adhered sleeve may detached from the output flange by the illegal torque or load.

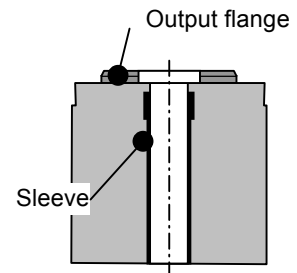

CAUTION

Do not disassemble and re-assemble the actuator.

The Harmonic Drive LLC does not guarantee the actuator that has been reassembled by others than the authorized persons by the Harmonic Drive LLC.

3-4 Extension Cables

Three kinds of optional extension cables, 3m/5m/10m length, are available for Absolute encoder.

Ordering model

For Motor: EWC – MBxx – A06 – SP

For Absolute encoder: EWD – Sxx – A08 – SP

xx ----- Cable length: L

03	3m
05	5m
10	10m

External view of extension cable for motor

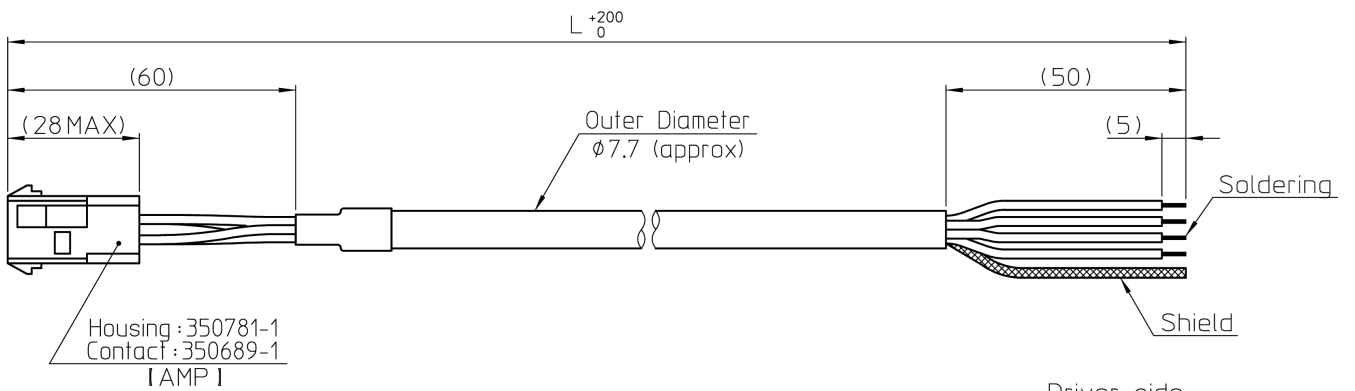

Driver side

Color	Signal
Red	U
White	V
Black	W
Green/Yellow	PE
Shield	—

External view of extension cable for absolute encoder

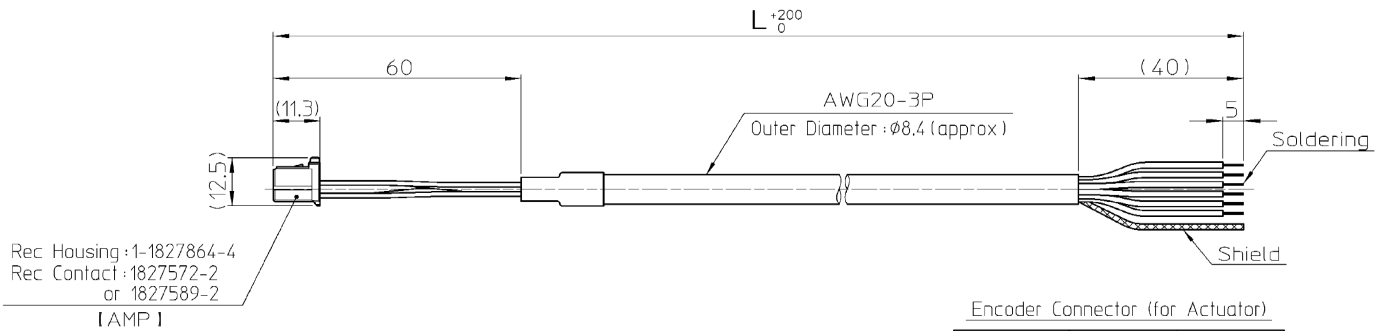

Encoder Connector (for Actuator)

1-1827864-4 Pin No.	Color	Signal
1A	Pink/1R	Vcc
1B	Pink/1B	GND (Vcc)
2A	Green/1R	SD+
2B	Green/1B	SD-
3A	—	—
3B	—	Shield
4A	Blue/1R	Vbat
4B	Blue/1B	GND (bat)

Appendix 1

Incremental Encoder Detailed Specifications

Signal Waveform

Fig. 1 A, B and Z signal and relationship with U-N motor EMF waveform with CW rotation facing the output flange end

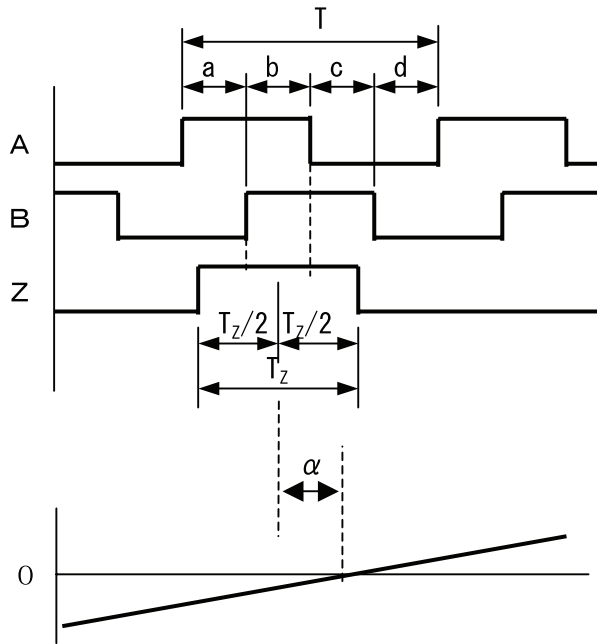

$$a, b, c, d = 0.25T \pm 0.15T$$

$$Tz = T \pm 0.5T$$

(The Z phase includes a HIGH state in case of both of A and B phase is HIGH state.)

$$T = 360^\circ / 2000$$

$$\leq \pm 3^\circ \text{ (Mechanical angle)}$$

U-N

Motor EMF waveform

Fig. 2 U, V and W signal and relationship with motor's EMF with CW rotation facing the output flange end

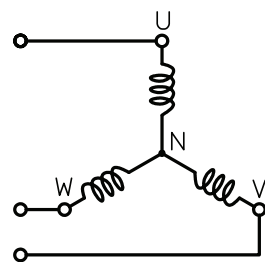
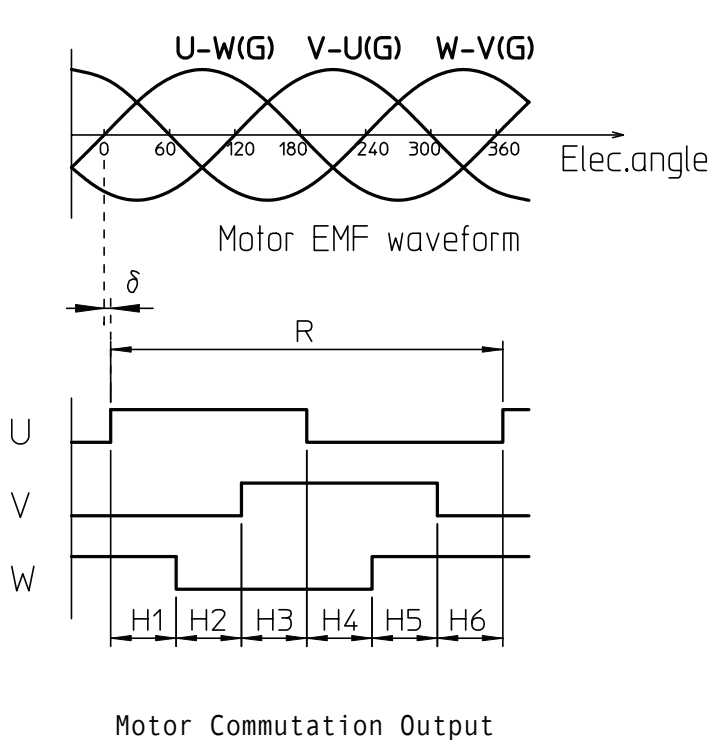

$$R = 72^\circ \pm 3^\circ \text{ (Mechanical angle)}$$

$$Hn = 12^\circ \pm 3^\circ \text{ (Mechanical angle)}$$

$$\leq \pm 3^\circ \text{ (Mechanical angle)}$$

Output Circuit and Example for Receiving Signal

Fig. 3 Output circuit of encoder and connection example

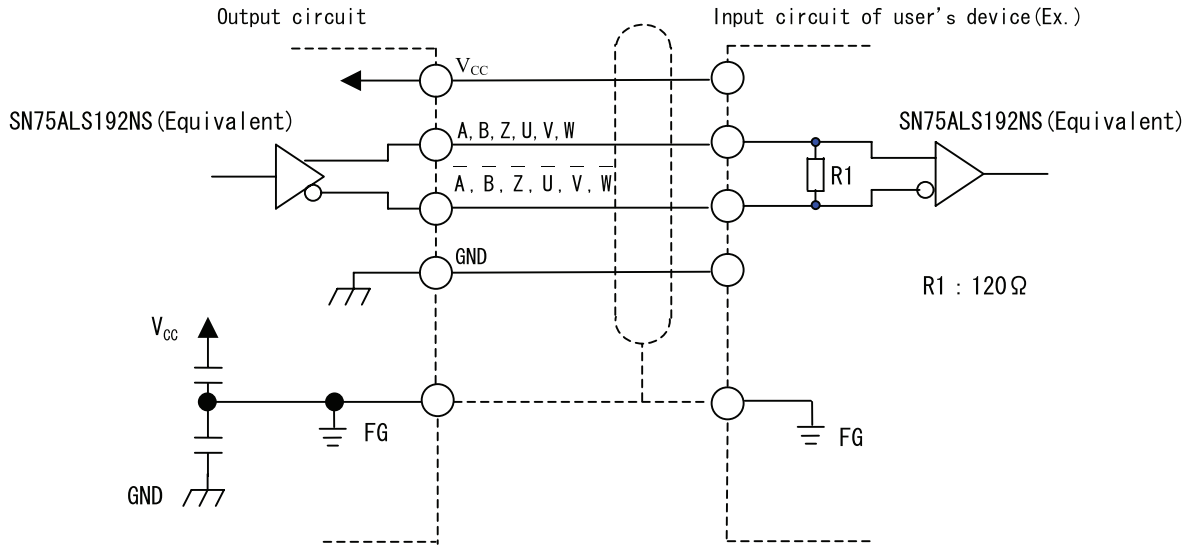

Voltage strength of capacitor C1, C2: 50V

Appendix 2 Unit conversion

This manual employs SI system for units. Conversion factors between the SI system and other systems are as follows:

(1) Length

SI system	m	
	↓	
Unit	ft.	in.
Factor	3.281	39.37

Unit	ft.	in.
Factor	0.3048	0.0254
	↓	
SI system	m	

(2) Linear speed

SI system	m/s			
	↓			
Unit	m/min	ft./min	ft./s	in/s
Factor	60	196.9	3.281	39.37

Unit	m/min	ft./min	ft./s	in/s
Factor	0.0167	5.08×10^{-3}	0.3048	0.0254
	↓			
SI system	m/s			

(3) Linear acceleration

SI system	m/s^2			
	↓			
Unit	m/min^2	$ft./min^2$	$ft./s^2$	in/s^2
Factor	3600	1.18×10^4	3.281	39.37

Unit	m/min^2	$ft./min^2$	$ft./s^2$	in/s^2
Factor	2.78×10^{-4}	8.47×10^{-5}	0.3048	0.0254
	↓			
SI system	m/s^2			

(4) Force

SI system	N		
	↓		
Unit	kgf	lb(force)	oz(force)
Factor	0.102	0.225	4.386

Unit	kgf	lb(force)	oz(force)
Factor	9.81	4.45	0.278
	↓		
SI system	N		

(5) Mass

SI system	kg	
	↓	
Unit	lb.	oz.
Factor	2.205	35.27

Unit	lb.	oz.
Factor	0.4535	0.02835
	↓	
SI system	kg	

(6) Angle

SI system	rad		
↓			
Unit	Degree	Minute	Second
Factor	57.3	3.44x10 ³	2.06x10 ⁵

Unit	Degree	Minute	Second
Factor	0.01755	2.93x10 ⁻⁴	4.88x10 ⁻⁶
↓			
SI system	rad		

(7) Angular speed

SI system	rad/s			
↓				
Unit	deg/s	deg/min	r/s	r/min
Factor	57.3	3.44x10 ³	0.1592	9.55

Unit	deg/s	deg/min	r/s	r/min
Factor	0.01755	2.93x10 ⁻⁴	6.28	0.1047
↓				
SI system	rad/s			

(8) Angular acceleration

SI system	rad/s ²	
↓		
Unit	deg/s ²	deg/min ²
Factor	57.3	3.44x10 ³

Unit	deg/s ²	deg/min ²
Factor	0.01755	2.93x10 ⁻⁴
↓		
SI system	rad/s ²	

(9) Torque

SI system	N·m			
↓				
Unit	kgf·m	lb·ft	lb·in	oz·in
Factor	0.102	0.738	8.85	141.6

Unit	kgf·m	lb·ft	lb·in	oz·in
Factor	9.81	1.356	0.1130	7.06x10 ⁻³
↓				
SI system	N·m			

(10) Moment of inertia

SI system	kg·m ²							
↓								
Unit	kgf·m·s ²	kgf·cm·s ²	lb·ft ²	lb·ft·s ²	lb·in ²	lb·in·s ²	oz·in ²	oz·in·s ²
Factor	0.102	10.2	23.73	0.7376	3.42x10 ³	8.85	5.47x10 ⁴	141.6

Unit	kgf·m·s ²	kgf·cm·s ²	lb·ft ²	lb·ft·s ²	lb·in ²	lb·in·s ²	oz·in ²	oz·in·s ²
Factor	9.81	0.0981	0.0421	1.356	2.93x10 ⁻⁴	0.113	1.829x10 ⁻⁵	7.06x10 ⁻³

SI system	kg·m ²							
-----------	-------------------	--	--	--	--	--	--	--

(11) Torsional spring constant, moment stiffness

SI system	N·m/rad				
↓					
Unit	kgf·m/rad	kgf·m/arc min	kgf·m/deg	lb·ft/deg	lb·in/deg
Factor	0.102	2.97x10 ⁻⁵	1.78x10 ⁻³	0.0129	0.1546

Unit	kgf·m/rad	kgf·m/arc min	kgf·m/deg	lb·ft/deg	lb·in/deg
Factor	9.81	3.37x10 ⁴	562	77.6	6.47

SI system	N·m/rad				
-----------	---------	--	--	--	--

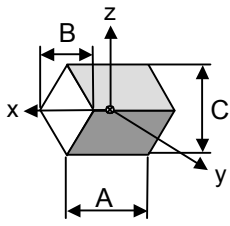
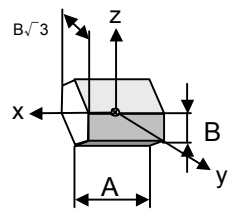
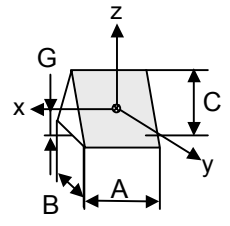
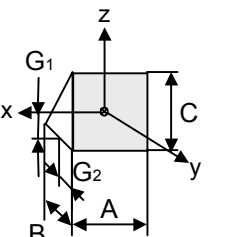
Object form	Mass, inertia, gravity center	Object form	Mass, inertia, gravity center
<p>Rhombus pillar</p> 	$m \ 8 \ \frac{1}{2} ABC\rho$ $I_x \ 8 \ \frac{1}{24} m \left(\frac{C}{3} \right)^2 \Rightarrow C^2 \ell$ $I_y \ 8 \ \frac{1}{24} m \left(\frac{C}{3} \right)^2 \Rightarrow 2A^2 \ell$ $I_z \ 8 \ \frac{1}{24} m \left(\frac{C}{3} \right)^2 \Rightarrow 2A^2 \ell$	<p>Hexagonal pillar</p> 	$m \ 8 \ \frac{3\sqrt{3}}{2} AB^2 \rho$ $I_x \ 8 \ \frac{5}{12} m B^2$ $I_y \ 8 \ \frac{1}{12} m \left(\frac{A}{2} \right)^2 \Rightarrow \frac{5}{2} B^2 \ell$ $I_z \ 8 \ \frac{1}{12} m \left(\frac{A}{2} \right)^2 \Rightarrow \frac{5}{2} B^2 \ell$
<p>Isosceles triangle pillar</p> 	$m \ 8 \ \frac{1}{2} ABC\rho$ $I_x \ 8 \ \frac{1}{12} m \left(\frac{B}{2} \right)^2 \Rightarrow \frac{2}{3} C^2 \ell$ $I_y \ 8 \ \frac{1}{12} m \left(\frac{A}{2} \right)^2 \Rightarrow \frac{2}{3} C^2 \ell$ $I_z \ 8 \ \frac{1}{12} m \left(\frac{A}{2} \right)^2 \Rightarrow \frac{B^2}{2} \ell$ $G_1 \ 8 \ \frac{C}{3}$	<p>Right triangle pillar</p> 	$m \ 8 \ \frac{1}{2} ABC\rho$ $I_x \ 8 \ \frac{1}{36} m \left(\frac{B}{2} \right)^2 \Rightarrow C^2 \ell$ $I_y \ 8 \ \frac{1}{12} m \left(\frac{A}{2} \right)^2 \Rightarrow \frac{2}{3} C^2 \ell$ $I_z \ 8 \ \frac{1}{12} m \left(\frac{A}{2} \right)^2 \Rightarrow \frac{2}{3} B^2 \ell$ $G_1 \ 8 \ \frac{C}{3} \quad G_2 \ 8 \ \frac{B}{3}$

◆ Example of specific gravity

The following tables show references of specific gravity. Confirm the specific gravity for the material of the drive load.

Material	Gravity	Material	Gravity	Material	Gravity
SS45C	7.86	Blonze	8.5	Epoxy resin	1.9
SS41C	7.85	Aluminum	2.7	ABS	1.1
Cast steel	7.85	Duralumin	2.8	Silicon resin	1.8
Cast iron	7.19	Teflon	2.2	Polyurethane rubber	1.25
Copper	8.92	Fluorocarbon resin	2.2	Chloroprene rubber	1.15

(2) Both center lines of rotation and gravity are not the same:

The following formula calculates the moment of inertia when the rotary center is different from the gravity center.

$$I \ 8 \ I_g \Rightarrow mF^2$$

- I : Inertia when both centers are not the same (kg·m²)
- I_g : Inertia when both centers are the same (kg·m²)
Calculate with formulas described in (1).
- m : Mass (kg)
- F : Distance between rotary center and gravity center (m)

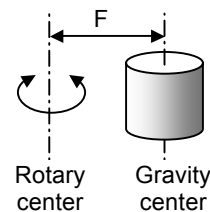

(3) Inertia of linearly moving objects

The inertia, converted to the actuator axis, of linear moving objects is calculated with the formula as follows:

$$I \ 8 \ m \left(\frac{P}{2\pi} \right)^2$$

- I: Inertia of linearly moving objects, converted to the actuator axis (kg·m²)
- m: Mass (kg)
- P: Displacement per one revolution of actuator (m/rev)

3-2 Inertia of cylinder

The moment of inertia of a cylinder may be obtained from the graphs to the right.

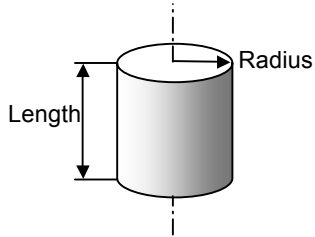

The above graph is applied for aluminum (specific gravity: 2.7) and the lower for steel (specific gravity: 7.85).

The double-dot-chain lines indicate the allowable inertia for each actuator.

(Example)

Material: Aluminum
 Diameter: 100mm
 Length: 7mm
 Form: cylinder

As the diameter is 100mm, the radius is 50mm. Therefore, the above graph would indicate that the inertia is:

Approx. $1.9 \times 10^{-4} \text{ kg} \cdot \text{m}^2$

(Exact value: $0.000186 \text{ kg} \cdot \text{m}^2$)

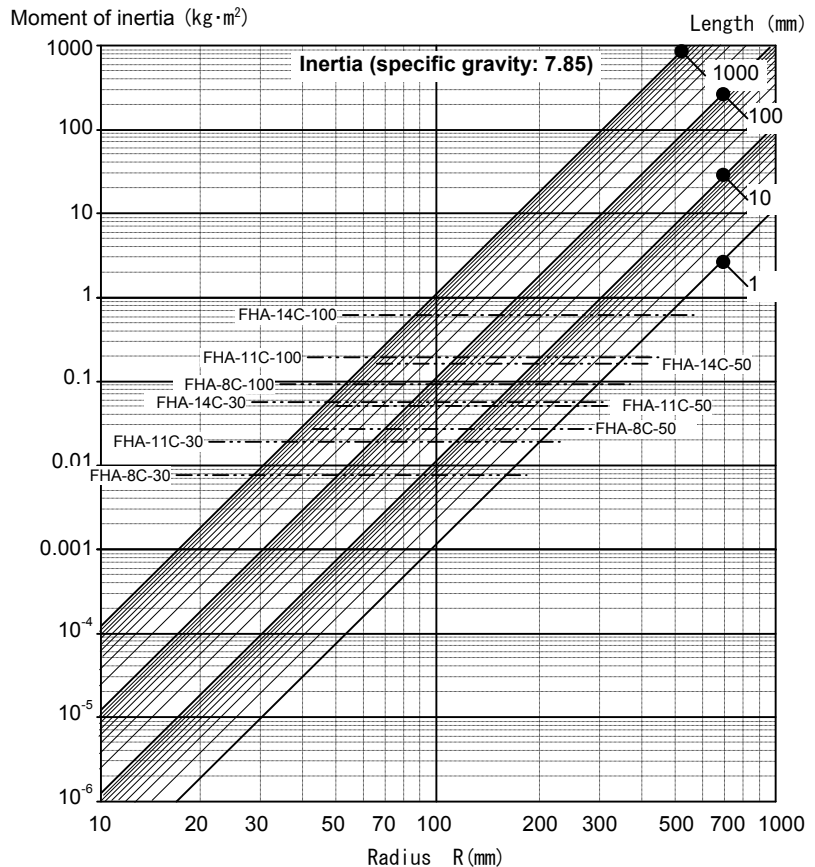
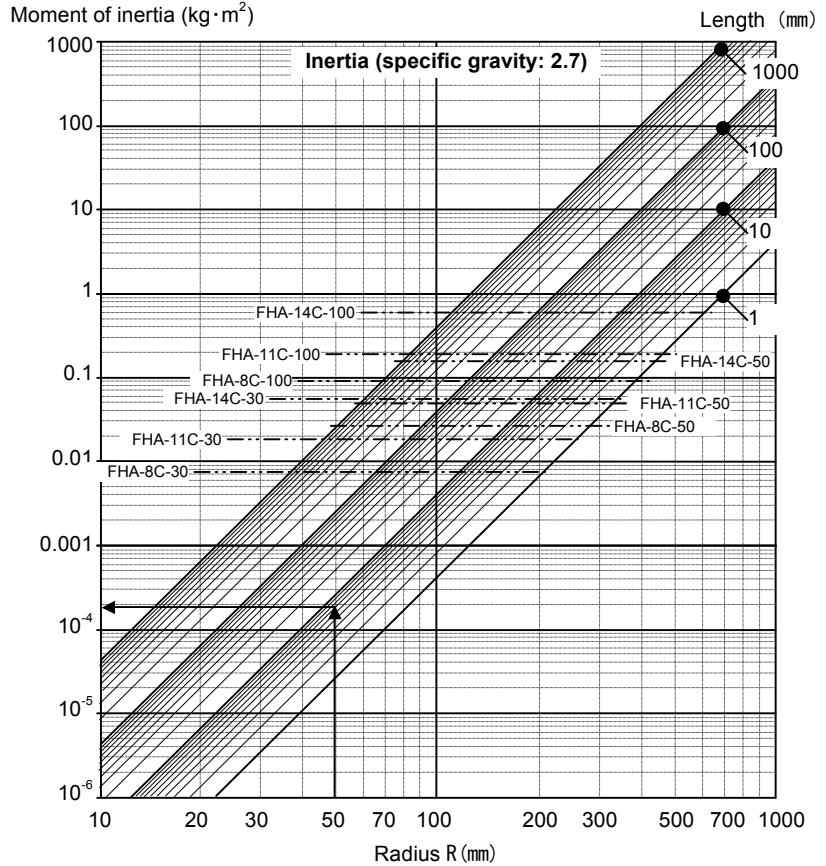

Warranty Period and Terms

The FHA-C mini series actuators are warranted as follows:

- **Warranty period**

Under the condition that the actuator is handled, used and maintained properly followed each item of the documents and the manuals, all the FHA-C mini series actuators are warranted against defects in workmanship and materials for the shorter period of either one year after delivery or 2,000 hours of operation.

- **Warranty terms**

All the FHA-C mini series actuators are warranted against defects in workmanship and materials for the warranted period. This limited warranty does not apply to any product that has been subject to:

- (1) user's misapplication, improper installation, inadequate maintenance, or misuse.
- (2) disassembling, modification or repair by others than Harmonic Drive LLC
- (3) imperfection caused by the other than the FHA-C mini series actuator and the HA-800, REL-230, RTL-230 servo drivers.
- (4) disaster or others that does not belong to the responsibility of Harmonic Drive LLC

Our liability shall be limited exclusively to repairing or replacing the product only found by Harmonic Drive LLC to be defective. Harmonic Drive LLC shall not be liable for consequential damages of other equipment caused by the defective products, and shall not be liable for the incidental and consequential expenses and the labor costs for detaching and installing to the driven equipment.

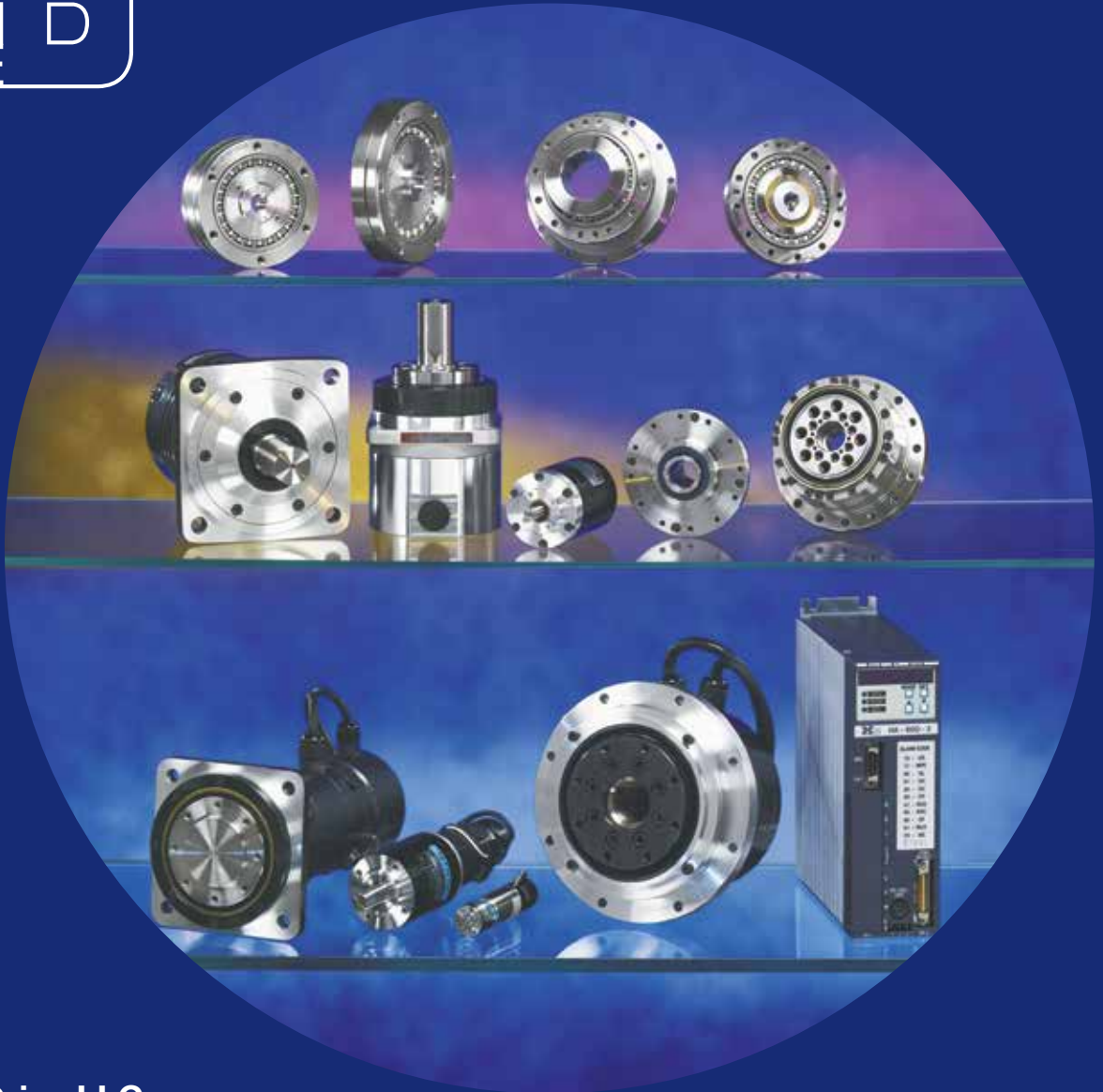

Harmonic Drive LLC

Boston US Headquarters

247 Lynnfield Street
Peabody, MA 01960

New York Sales Office

100 Motor Parkway
Suite 116
Hauppauge, NY 11788

California Sales Office

333 W. San Carlos Street
Suite 1070
San Jose, CA 95110

Chicago Sales Office

137 N. Oak Park Ave., Suite 410
Oak Park, IL 60301

T: 800.921.3332

T: 978.532.1800

F: 978.532.9406

Group Companies

Harmonic Drive Systems, Inc.
6-25-3 Minami-Ohi, Shinagawa-ku
Tokyo 141-0013, Japan

Harmonic Drive AG
Hoenbergstrasse, 14, D-6555
Limburg/Lahn Germany



www.HarmonicDrive.net

Harmonic Drive is a registered trademark of Harmonic Drive LLC.

Rev 6-14