

HarmonicDrive®

Speed Reducers for Precision Motion Control

HarmonicDrive® Reducer Catalog

- Differential Gear FBB
- Engineering Data

NOTE: This is a section from our full Reducer Product Catalog.
Page numbers are for reference only.

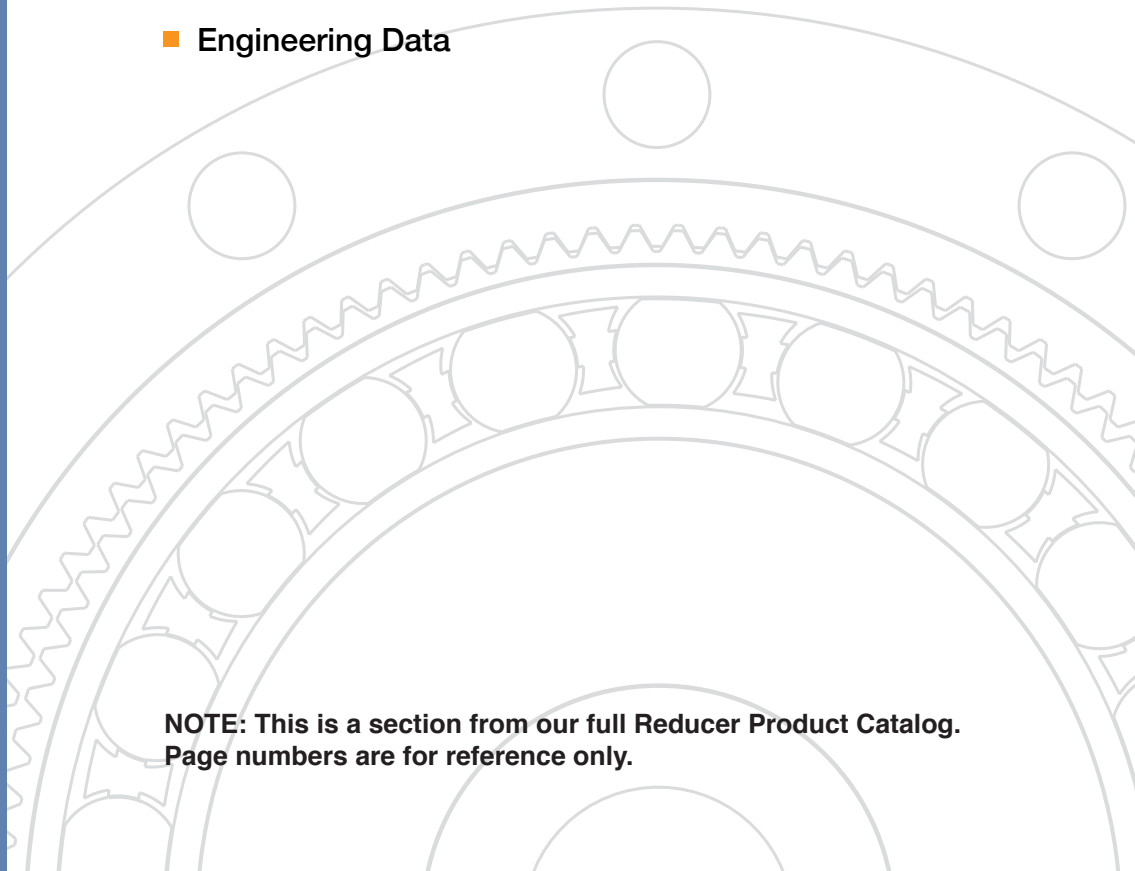

Excellent Technology for Evolving Industries

Harmonic Drive® actuators utilize high-precision, zero-backlash Harmonic Drive® precision gears and play critical roles in robotics, semiconductor manufacturing equipment, factory automation equipment, medical diagnostics and surgical robotics. Additionally, our products are frequently used in mission-critical spaceflight applications which capture the human spirit.

With over 50 years of experience, our expert engineering and production teams continually develop enabling technologies for the evolving motion control market. We are proud of our outstanding engineering capabilities and successful history of providing customer specific solutions to meet their application requirements.

Harmonic Drive LLC continues to develop enabling technologies for the evolving motion control market, which drives the pace of global innovation.

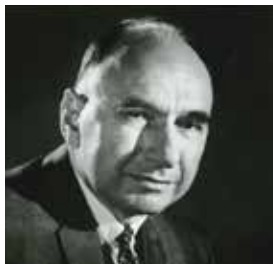

C. Walton Musser
Patented Strain Wave
Gearing in 1955

Operating Principle of HarmonicDrive® Gears

A simple three-element construction combined with the unique operating principle puts extremely high reduction ratio capabilities into a very compact and lightweight package. The high-performance attributes of this gearing technology including, zero-backlash, high-torque-to-weight ratio, compact size, and excellent positional accuracy, are a direct result of the unique operating principles.



Wave Generator

The Wave Generator is a thin, raced-ball bearing fitted onto an elliptical hub. This serves as a high-efficiency torque converter and is generally mounted onto the input or motor shaft.

Flexspline

The Flexspline is a non-rigid, thin cylindrical cup with external teeth on the open end of the cup. The Flexspline fits over the Wave Generator and takes on its elliptical shape. The Flexspline is generally used as the output of the gear.

Circular Spline

The Circular Spline is a rigid ring with internal teeth. It engages the teeth of the Flexspline across the major axis of the Wave Generator ellipse. The Circular Spline has two more teeth than the Flexspline and is generally mounted onto a housing.

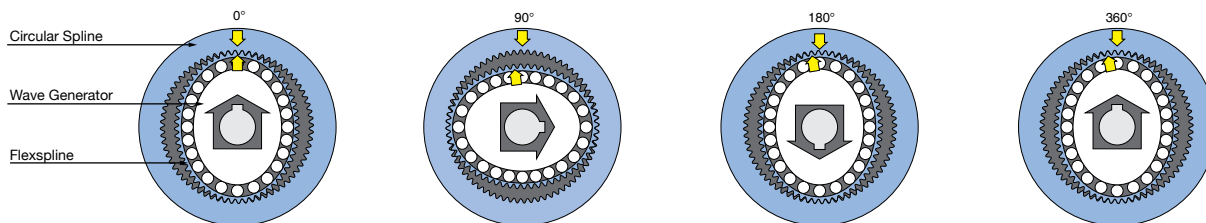

The Flexspline is slightly smaller in diameter than the Circular Spline and usually has two fewer teeth than the Circular Spline. The elliptical shape of the Wave Generator causes the teeth of the Flexspline to engage the Circular Spline at two opposite regions across the major axis of the ellipse.

As the Wave Generator rotates the teeth of the Flexspline engage with the Circular Spline at the major axis.

For every 180 degree clockwise movement of the Wave Generator, the Flexspline rotates counterclockwise by one tooth in relation to the Circular Spline.

Each complete clockwise rotation of the Wave Generator results in the Flexspline moving counterclockwise by two teeth from its original position, relative to the Circular Spline. Normally, this motion is taken out as output.

Development of HarmonicDrive® Speed Reducers



Harmonic Drive® gears have been evolving since the strain wave gear was first patented in 1955. Our innovative development and engineering teams have led us to significant advances in our gear technology. In 1988, Harmonic Drive successfully designed and manufactured a new tooth profile, the "S" tooth. Since implementing the "S" tooth profile, improvement in life, strength and torsional stiffness have been realized. In the 1990s, we focused engineering efforts on designing gears featuring space savings, higher speed, higher load capacity and higher reliability. Then in the 2000s, significant reduction in size and thickness were achieved, all while maintaining high precision specifications.

HarmonicDrive®





NOTE: This is a section from our full Reducer Product Catalog. Page numbers are for reference only.

FBB Series

Differential Gear FBB

Features	304
Ordering code	306
Assembly	306
Rating Table	307
Outline Dimensions	308
Dimensions	309
Engineering.....	009

Features

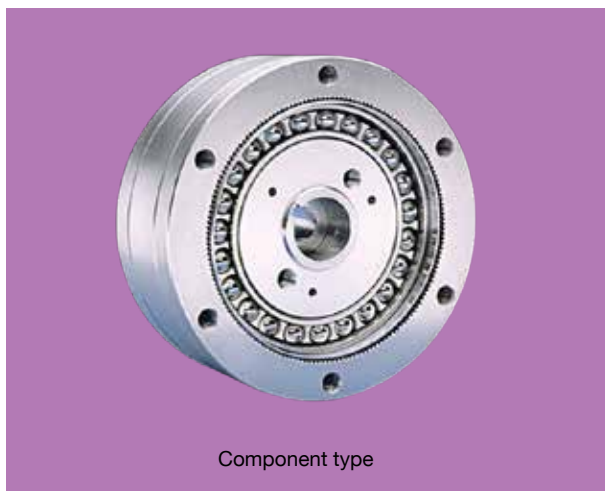

Component type

Differential & Phasing Drive

The FBB was developed as a versatile simple differential drive transmission for direct phasing of rotating elements while they are in motion. Offsetting internal gear ratios deliver a through ratio of 1:1 and trim adjustments can be applied through one or both of two wave generators.

Features

- For dynamic registration of rotating elements
- A 1:1 differential with high-ratio trim adjustment
- Ideal differential for roll registration or angular shaft phasing
- Compact, low-backlash design for end-of-roll mounting

Axially Compact, Single-Stage, High-Ratio Gearing

DYNAMIC CIRCULAR SPLINE:

An internal gear which has the same number of teeth as the Flexspline and which rotates at the same speed and in the same direction as the Flexspline. It usually is the output element to which an output shaft is connected.

FLEXSPLINE:

External spline teeth that progressively engage the internal teeth of the Static Circular Spline and Dynamic Circular Spline at the major axis of its rotating elliptical shape. Speed reduction relative to the Wave Generator is equal to one-half the number of teeth on the Flexspline's outside edge. For example, if the Flexspline has 200 teeth, the reduction ratio will be 100:1.

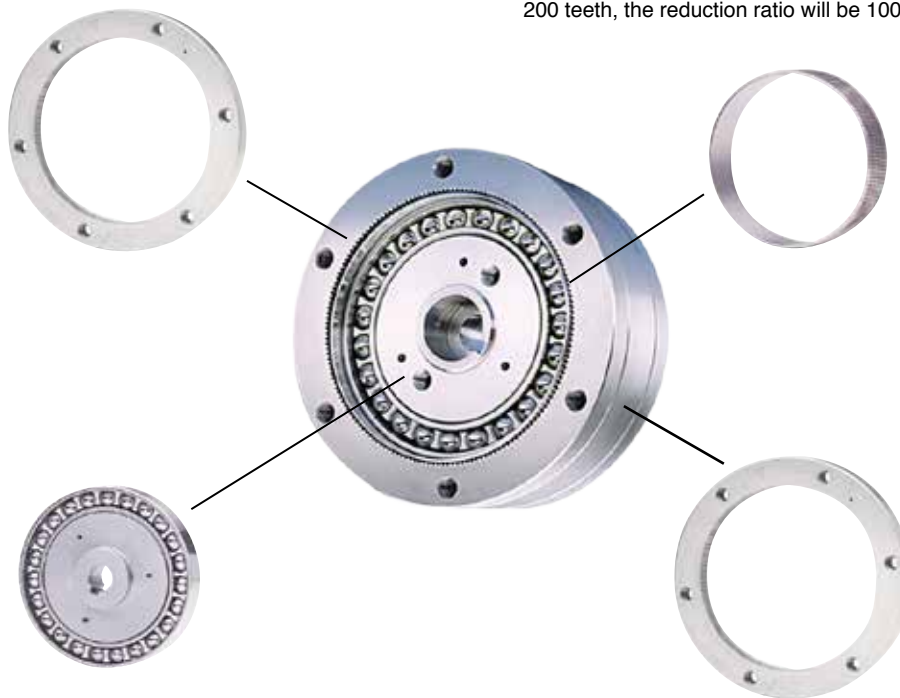

WAVE GENERATOR:

An elliptical bearing and the rotating input element of the transmission. It is connected to a motor or other input shaft and imparts a rotating elliptical shape to the Flexspline.

STATIC CIRCULAR SPLINE:

A fixed nonrotating internal gear which provides mechanical grounding for the transmission. It has two more teeth than the Flexspline to establish a positive transmission reduction ratio equal to one-half the number of Flexspline teeth.

FBB Phasing Differential Gear Sets

Harmonic Drive FBB gear sets allow easy and direct phasing of rotating elements and are ideally suited for web presses and other machines requiring constant monitoring and adjustment while they are in motion.

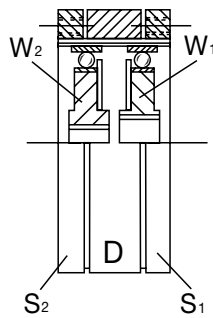

Drive Power

FBB is essentially two FB pancake gear sets mounted back to back with dynamic splines connected. The FBB provides a 1:1 through ratio from a primary drive source to secondary elements of a machine with optional speed or position adjustment.

Power is applied to S1, the first of three ring gears called circular splines. Torque is transmitted from the first circular spline to the third circular spline S2, through two gear ratios.

The first ratio is a slight speed increase between S1 and the middle circular spline D.

The second ratio is a very slight speed reduction between the D spline and the S2 circular spline.

When the two wave generators W1 and W2 are stationary, the increasing and decreasing ratios offset each other and the S1 and S2 circular splines rotate in the same direction and at the same speed. Power circulates from the S1 input to the S2 output at a 1:1 ratio with an efficiency of approximately 99%.

Trim

With one wave generator W1 rotationally fixed, a second wave generator W2 can be rotated to create, a high ratio advance or retardation (depending on direction) of S2 relative to the S1 circular spline.

Output speed or position can be accurately adjusted with the machine in motion. The output speed of S2 while trim is being applied can be calculated with the following equation:

$$N_{S2} = N_{S1} \pm \left[\frac{N_{W2}}{(R+1)} \right] \quad \text{Where } \begin{matrix} N = \text{speed} \\ R = \text{tabulated ratio} \end{matrix}$$

It is possible to attach both wave generators to different drive sources.

For example, W2 could be driven by a servomotor for high-speed automated trim and W1 to a hand crank for low speed manual trim.

Sufficient holding torque must be applied to the trim shaft to prevent rotation. This can be calculated from the following equation:

$$\text{Control Torque} = \frac{\text{System Output Torque (max)}}{\text{Ratio} \times 0.5}$$

Ratio

Standard ratios are as shown in the rating table page 3, however, other ratios are available on a custom basis (consult our engineering department).

Ratings

Torque ratings are as the equivalent size FB pancake gear set.

Relative Trim Direction

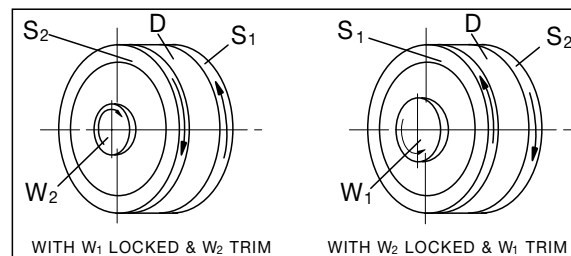

These examples show the displacement of the circular splines S1 and S2 relative to each other when the wave generator is rotated in the direction of the arrow. Actual rotational direction will depend on the direction of the main input drive

Ordering Code

FBB - 20 - 80 - 2 - SP

Table 306-1

Series	Size	Ratio ^{*1}																Model			
FBB	20	-	80	-	-	100	-	-	-	128	-	-	-	160	-	-	-	-	-	2= Component type	SP = Special specification code
	25	-	80	-	-	100	-	-	-	120	-	-	-	160	-	200	-	-	-		
	32	78	-	-	-	100	-	-	-	-	131	-	157	-	-	200	-	-	260		
	40	-	80	-	-	100	-	-	-	128	-	-	-	160	-	200	-	-	258		
	50	-	80	-	-	100	-	-	-	120	-	-	-	160	-	200	-	242	-		

*1 The reduction ratio value is based on the following configuration:
 Input: wave generator, fixed: circular spline S, output: circular spline D

Figure 306-1

Assembly

FBB differentials are supplied as component sets only and are not self contained power transmissions. Suitable housings with bearing supports, oil reservoirs and seals must be provided.

Circular Splines

Both S1 & S2 circular splines must be supported with a suitable bearing arrangement to maintain specified dimensions and tolerances under all load conditions.

Overhung loads from an external source require a suitable two-bearing or four-point contact bearing support.

Axial restraint in both directions must maintain the gap between each of the three circular splines.

Flexspline

Hardened wear washers are provided to prevent axial displacement of the flexspline. These may be discarded if the customer supplied components in the vicinity of the flexspline are a minimum hardness of Rc45.

Wave Generator

The wave generator bearings should not be used to support a shaft. Axial restraint in both directions should be provided.

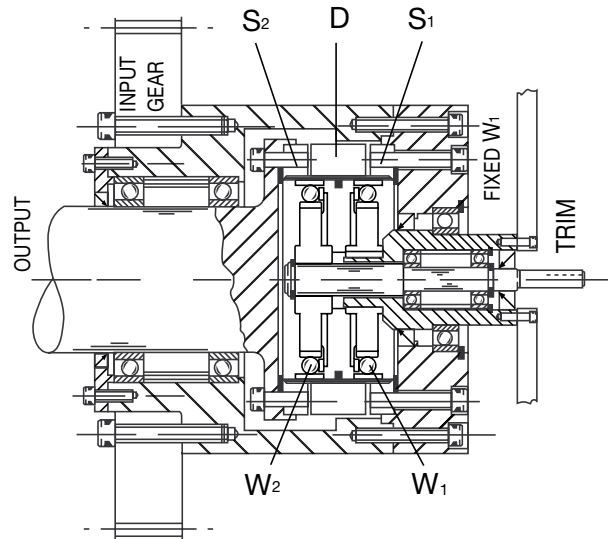

Rating table

Table 307-2

Size	Ratio	Maximum Input Speed rpm		Rated Torque @1750 rpm	Maximum Output Torque	No Load Starting Torque	Input Inertia
		Oil	Grease	Nm	Nm	Ncm	kgcm ²
20	80	6000	3500	28	28	3.2	0.14
	100			28	34	3.2	0.14
	120			28	40	3.2	0.14
	160			28	44	3.2	0.14
25	80	5000	3500	46	48	4.2	0.36
	100			46	68	4.2	0.36
	120			46	79	4.2	0.36
	160			46	88	4.2	0.36
32	80	4500	3500	92	107	5.7	1.32
	100			92	136	5.7	1.32
	120			92	158	5.7	1.32
	160			92	175	5.7	1.32
40	80	4000	3000	193	192	19.1	3.42
	100			193	271	19.1	3.42
	120			193	305	19.1	3.42
	160			193	350	19.1	3.42
50	80	3500	2500	359	350	35.3	9.91
	100			359	475	35.3	9.91
	120			359	588	35.3	9.91
	160			359	655	35.3	9.91

Engineering Data

Component Sets

Gear Units

Phase Adjusters

Gearheads & Actuators

Differential Gear FBB

Outline Dimensions

Figure 308-1

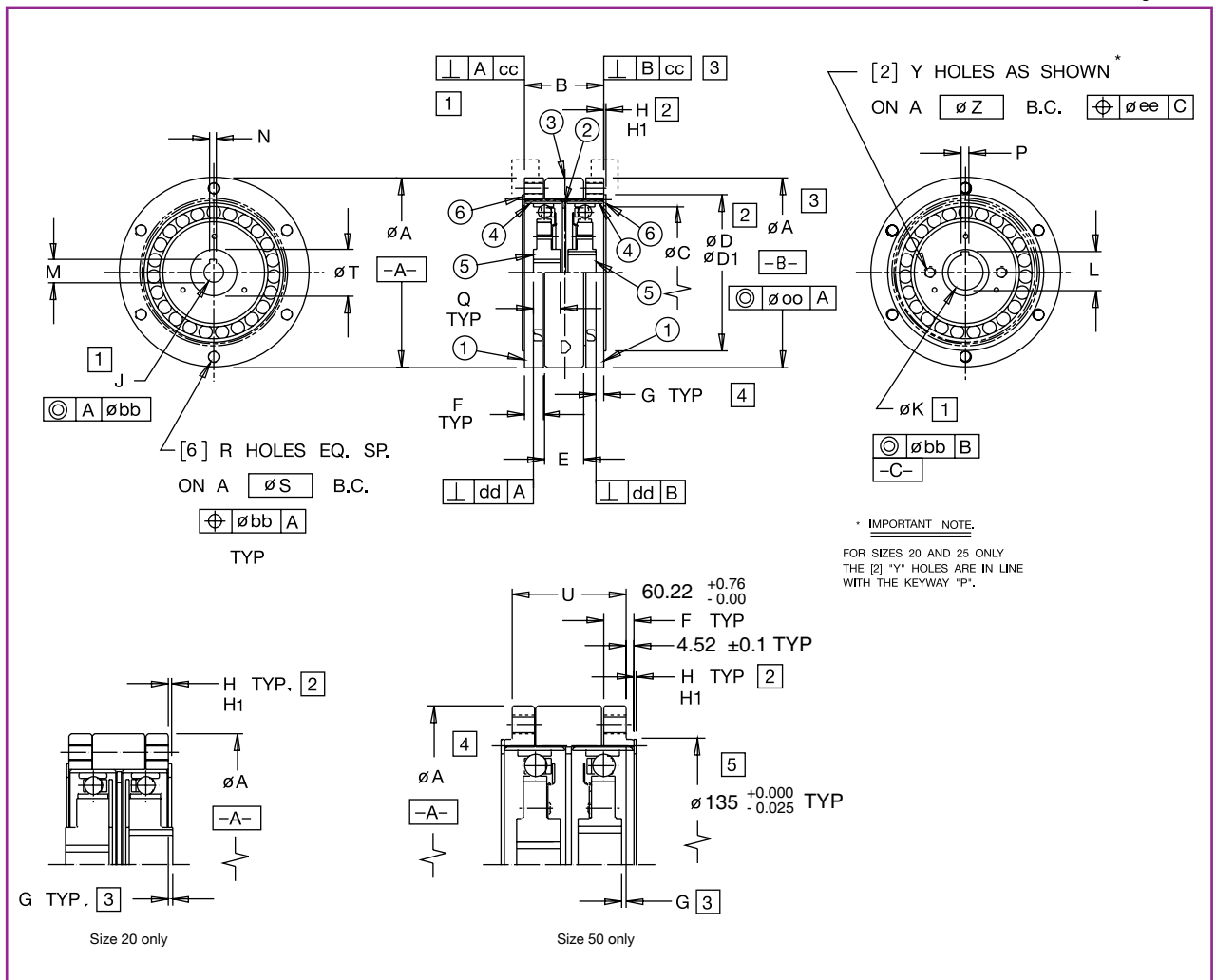

- A. Item ① Static Circular Spline **Marked S**
Item ② Spacer
Item ③ Dynamic Circular Spline **Marked D**
Item ④ Flexspline
Item ⑤ Wave Generator
Item ⑥ Wear washer
- B. Dimensions marked ① established interface and installation requirements and must be maintained under all operating conditions
- C. Dimensions marked ② are necessary to locate wear washers item ⑥ in correct position. See assembly notes.

Dimensions

Table 309-1
Unit: mm

Size Symbol	20	25	32	40	50
ØA	70 ^{-0.018}	85 ^{-0.022}	110 ^{-0.025}	134 ^{-0.025}	170 ^{-0.025}
B	26.5 ^{+0.25}	34.8 ^{+0.25}	42 ^{+0.6}	56.5 ^{+0.8}	-
ØC	47 ^{+0.51}	59 ^{+0.51}	77 ^{+0.51}	95 ^{+0.51}	119 ^{+0.51}
ØD	54 ^{+0.51}	69.4 ^{+0.51}	92 ^{+0.51}	111.1 ^{+0.51}	134.4 ^{+0.51}
ØD1	54.7 ^{+0.51}	70.2 ^{+0.51}	92.9 ^{+0.38}	92.9 ^{+0.38}	135.2 ^{+0.38}
E	14 ^{+0.1}	18 ^{+0.1}	20.9 ^{+0.1}	28 ^{+0.1}	35 ^{+0.2}
F	6 ^{+0.1}	8 ^{+0.2}	10 ^{+0.2}	13 ^{+0.2}	13 ^{+0.2}
G	1.8 ^{±.51}	3.27 ^{±.51}	3.95 ^{±.51}	1.95 ^{±.51}	1.4 ^{±.51}
H	.81 ^{+0.13}	.81 ^{+0.13}	.81 ^{+0.13}	1.57 ^{+0.13}	1.57 ^{+0.13}
H1	.94 ^{+0.13}	.94 ^{+0.13}	.94 ^{+0.13}	1.69 ^{+0.13}	1.69 ^{+0.13}
ØJ	9 ^{+0.015}	11 ^{+0.018}	14 ^{+0.020}	14 ^{+0.020}	19 ^{+0.020}
ØK	16 ^{+0.013}	19 ^{+0.013}	25 ^{+0.020}	25 ^{+0.020}	35 ^{+0.023}
L	17.4 ^{+0.10}	20.8 ^{+0.10}	27.3 ^{+0.20}	27.3 ^{+0.20}	38.3 ^{+0.20}
M	10.4 ^{+0.10}	12.8 ^{+0.10}	16.3 ^{+0.10}	16.3 ^{+0.10}	21.8 ^{+0.10}
N	3 ^{+0.0125}	4 ^{+0.013}	5 ^{+0.013}	5 ^{+0.013}	6 ^{+0.013}
P	3 ^{+0.0125}	4 ^{+0.013}	5 ^{+0.013}	5 ^{+0.013}	10 ^{+0.023}
Q	11.4	12.8	15.6	19.4	23.2
R	M4 x 0.7	M5 x 0.8	M6 x 1	M8 x 1.25	M10 x 1.5
ØS	60	75	100	120	150
ØT	20	28	36	32	50
Y	M4 x 0.7	M4 x 0.7	M6 x 1.0	M8 x 1.25	M8 x 1.25
ØZ	27	35	44	48	65
aa	0.07	0.076	0.078	0.088	0.098
bb	0.013	0.015	0.015	0.018	0.020
cc	0.018	0.023	0.025	0.025	0.025
dd	0.010	0.013	0.013	0.013	0.015
ee	0.250	0.250	0.250	0.250	0.250
mass (lb/kgf)	1.50/70	2.70/1.23	4.70/2.14	9.00/4.09	15.30/6.9

Engineering Data

Component Sets

Gear Units

Phase Adjusters

Gearheads & Actuators

Engineering Data

Engineering Data

Tooth profile	• S tooth profile	009
Rotational direction and reduction ratio	• Cup style	010
	• Silk hat style	010
	• Pancake style	011
Rating table definitions		012
Life		012
Torque limits		013
Product sizing and selection		014
Lubrication	• Grease lubricant	016
	• Precautions on using Harmonic Grease® 4B No.2	018
	• Oil lubricant	018
	• Lubricant for special environments	019
Torsional stiffness		020
Positional accuracy		021
Vibration		021
Starting torque		022
Backdriving torque		022
No-load running torque		023
Efficiency		023
Design guidelines	• Design guideline	024
	• Bearing support of the input and output shafts	025
	• Wave Generator	026
Assembly guidelines	• Sealing	028
	• Assembly Precautions	028
	• "dedoidal" state	029
Checking output bearing	• Checking procedure	030
	• How to calculate the maximum moment load	030
	• How to calculate the average load	031
	• How to calculate the radial load coefficient (X) and axial load coefficient (Y)	031
	• How to calculate life	032
	• How to calculate the life under oscillating movement	033
	• How to calculate the static safety coefficient	034

Tooth Profile

■ S tooth profile

Harmonic Drive developed a unique gear tooth profile that optimizes the tooth engagement. It has a special curved surface unique to the S tooth profile that allows continuous contact with the tooth profile. It also alleviates the concentration of stress by widening the width of the tooth groove against the tooth thickness and enlarging the radius on the bottom. This tooth profile (the "S tooth") enables up to 30% of the total number of teeth to be engaged simultaneously.

Additionally the large tooth root radius increases the tooth strength compared with an involute tooth. This technological innovation results in high torque, high torsional stiffness, long life and smooth rotation.

*Patented

Engaged route of teeth

Fig. 009-1

Conventional tooth profile

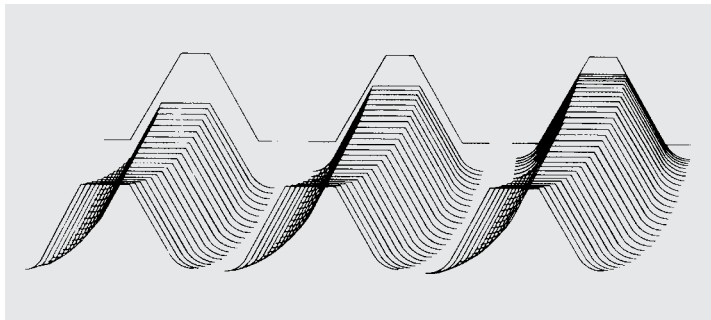

S tooth profile

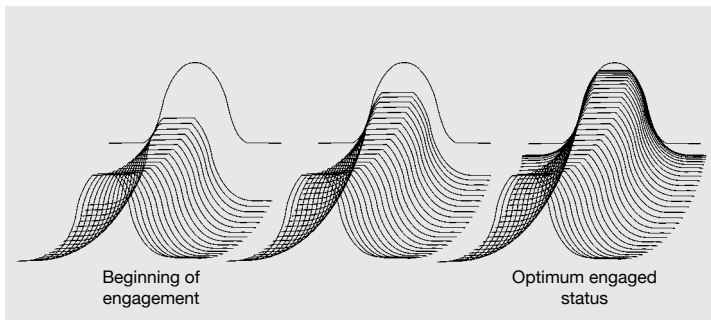

Engaged area of teeth

Fig. 009-2

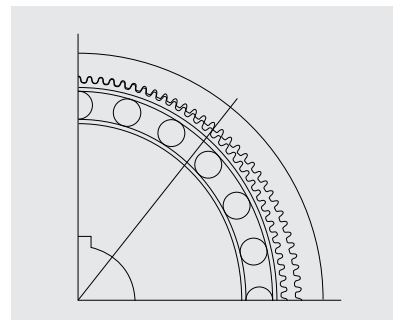
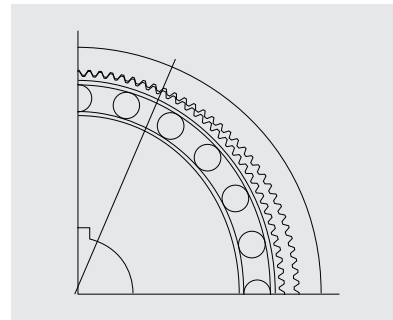

Rotational direction and reduction ratio

Cup Style

Series: CSG, CSF, CSD, CSF-mini

Rotational direction

Fig. 010-1

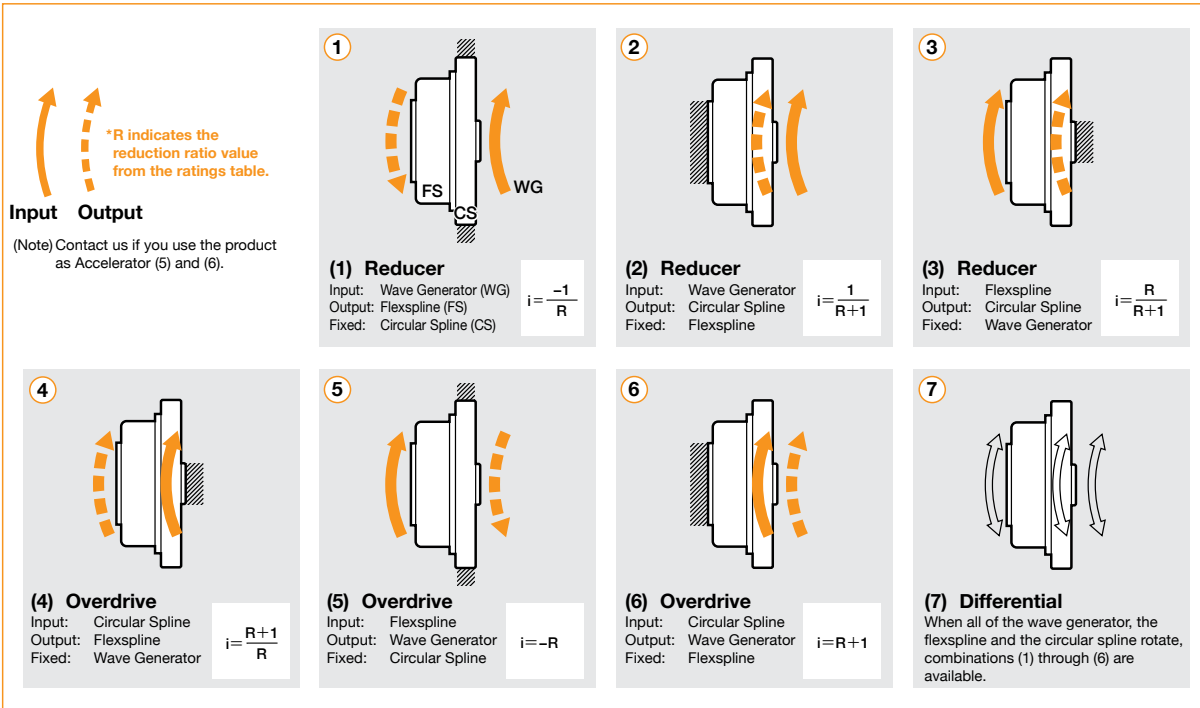

Silk hat

Series: SHG, SHF, SHD

Rotational direction

Fig. 010-2

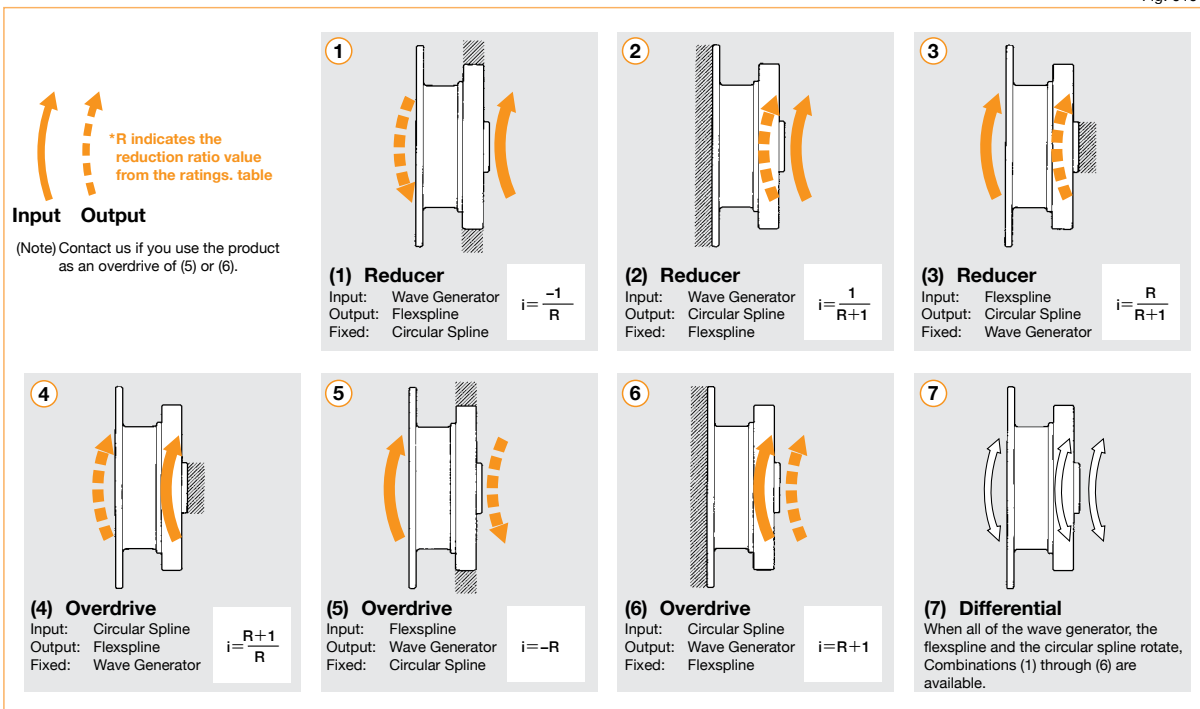

Pancake

Series: FB and FR

Rotational direction

Fig. 11-1

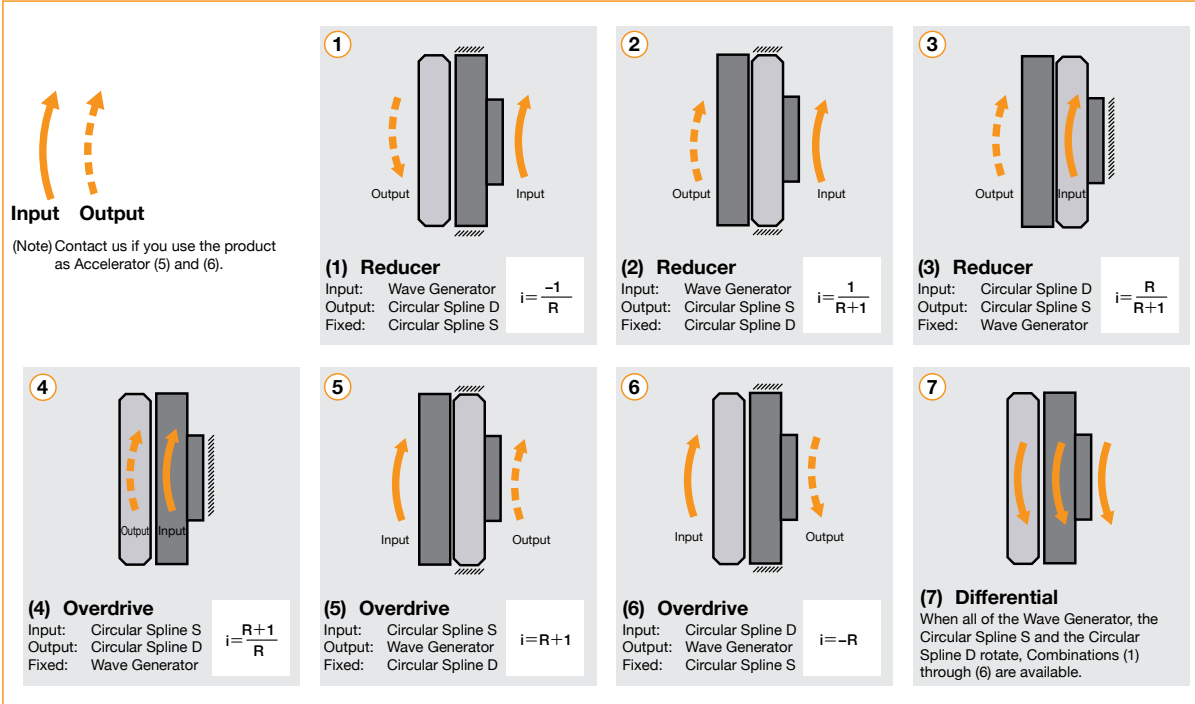

Reduction ratio

The reduction ratio is determined by the number of teeth of the Flexspline and the Circular Spline

Number of teeth of the Flexspline: Z_f
 Number of teeth of the Circular Spline: Z_c

Example

Number of teeth of the Flexspline: 200
 Number of teeth of the Circular Spline: 202

▶ Input: Wave Generator
 Output: Flexspline
 Fixed: Circular Spline } Reduction ratio $i_1 = \frac{1}{R_1} = \frac{Z_f - Z_c}{Z_f}$

▶ Input: Wave Generator
 Output: Flexspline
 Fixed: Circular Spline } Reduction ratio $i_1 = \frac{1}{R_1} = \frac{200 - 202}{200} = \frac{-1}{100}$

▶ Input: Wave Generator
 Output: Circular Spline
 Fixed: Flexspline } Reduction ratio $i_2 = \frac{1}{R_2} = \frac{Z_c - Z_f}{Z_c}$

▶ Input: Wave Generator
 Output: Circular Spline
 Fixed: Flexspline } Reduction ratio $i_2 = \frac{1}{R_2} = \frac{202 - 200}{202} = \frac{1}{101}$

■ R_1 indicates the reduction ratio value from the ratings table.

Rating Table Definitions

See the corresponding pages of each series for values.

Rated torque

Rated torque indicates allowable continuous load torque at rated input speed.

Limit for Repeated Peak Torque (see Graph 12-1)

During acceleration and deceleration the Harmonic Drive® gear experiences a peak torque as a result of the moment of inertia of the output load. The table indicates the limit for repeated peak torque.

Limit for Average Torque

In cases where load torque and input speed vary, it is necessary to calculate an average value of load torque. The table indicates the limit for average torque. The average torque calculated must not exceed this limit. (calculation formula: Page 14)

Limit for Momentary Peak Torque (see Graph 12-1)

The gear may be subjected to momentary peak torques in the event of a collision or emergency stop. The magnitude and frequency of occurrence of such peak torques must be kept to a minimum and they should, under no circumstance, occur during normal operating cycle. The allowable number of occurrences of the momentary peak torque may be calculated by using formula 13-1.

Maximum Average Input Speed Maximum Input Speed

Do not exceed the allowable rating. (calculation formula of the average input speed: Page 14).

Moment of Inertia

The rating indicates the moment of inertia reflected to the gear input.

Example of application motion profile

Graph 012-1

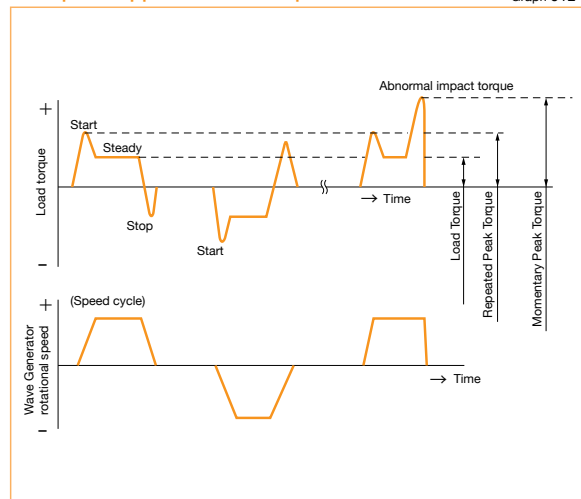

Life

Life of the wave generator

The life of a gear is determined by the life of the wave generator bearing. The life may be calculated by using the input speed and the output load torque.

Table 012-1

Series name	Life	
	CSF, CSD, SHF, SHD, CSF-mini	CSG, SHG
L ₁₀	7,000 hours	10,000 hours
L ₅₀ (average life)	35,000 hours	50,000 hours

* Life is based on the input speed and output load torque from the rating table.

Calculation formula for Rated Lifetime

Formula 012-1

$$L_h = L_n \cdot \left(\frac{T_r}{T_{av}} \right)^3 \cdot \left(\frac{N_r}{N_{av}} \right)$$

Table 012-2

L _n	Life of L ₁₀ or L ₅₀
T _r	Rated torque
N _r	Rated input speed
T _{av}	Average load torque on the output side (calculation formula: Page 14)
N _{av}	Average input speed (calculation formula: Page 14)

Relative torque rating

Graph 012-2

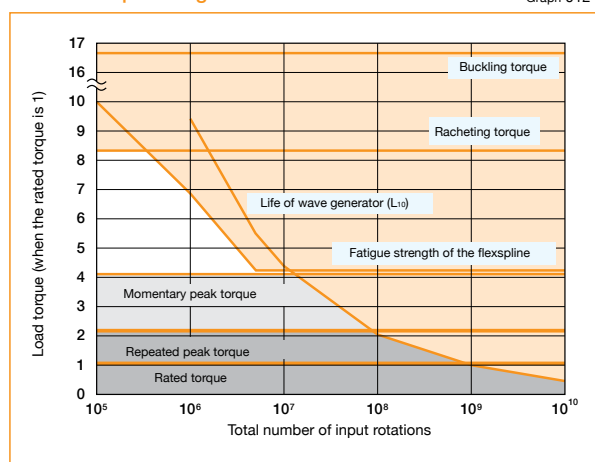

* Lubricant life not taken into consideration in the graph described above.

* Use the graph above as reference values.

Torque Limits

Strength of flexspline

The Flexspline is subjected to repeated deflections, and its strength determines the torque capacity of the Harmonic Drive® gear. The values given for Rated Torque at Rated Speed and for the allowable Repeated Peak Torque are based on an infinite fatigue life for the Flexspline.

The torque that occurs during a collision must be below the momentary peak torque (impact torque). The maximum number of occurrences is given by the equation below.

Allowable limit of the bending cycles of the flexspline during rotation of the wave generator while the impact torque is applied: 1.0×10^4 (cycles)

The torque that occurs during a collision must be below the momentary peak torque (impact torque). The maximum number of occurrences is given by the equation below.

Calculation formula

Formula 013-1

$$N = \frac{1.0 \times 10^4}{2 \times \frac{n}{60} \times t}$$

Allowable occurrences	N occurrences
Time that impact torque is applied	t sec
Rotational speed of the wave generator	n rpm
The flexspline bends two times per one revolution of the wave generator.	

Caution If the number of occurrences is exceeded, the Flexspline may experience a fatigue failure.

Buckling torque

When a highly excessive torque (16 to 17 times rated torque) is applied to the output with the input stationary, the flexspline may experience plastic deformation. This is defined as buckling torque.

* See the corresponding pages of each series for buckling torque values.

Warning When the flexspline buckles, early failure of the HarmonicDrive® gear will occur.

Ratcheting torque

When excessive torque (8 to 9 times rated torque) is applied while the gear is in motion, the teeth between the Circular Spline and Flexspline may not engage properly.

This phenomenon is called ratcheting and the torque at which this occurs is called ratcheting torque. Ratcheting may cause the Flexspline to become non-concentric with the Circular Spline. Operating in this condition may result in shortened life and a Flexspline fatigue failure.

* See the corresponding pages of each series for ratcheting torque values.
 * Ratcheting torque is affected by the stiffness of the housing to be used when installing the circular spline. Contact us for details of the ratcheting torque.

Caution When ratcheting occurs, the teeth may not be correctly engaged and become out of alignment as shown in Figure 013-1. Operating the drive in this condition will cause vibration and damage the flexspline.

Caution Once ratcheting occurs, the teeth wear excessively and the ratcheting torque may be lowered.

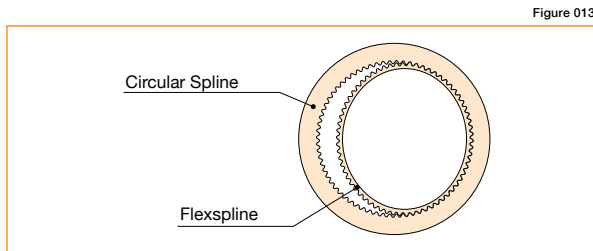

Figure 013-1

"Dedoidal" condition.

Product Sizing & Selection

In general, a servo system rarely operates at a continuous load and speed. The input rotational speed, load torque change and comparatively large torque are applied at start and stop. Unexpected impact torque may be applied. These fluctuating load torques should be converted to the average load torque when selecting a model number. As an accurate cross roller bearing is built in the direct external load support (output flange), the maximum moment load, life of the cross roller bearing and the static safety coefficient should also be checked.

■ Checking the application motion profile

Review the application motion profile. Check the specifications shown in the figure below.

Graph 14-1

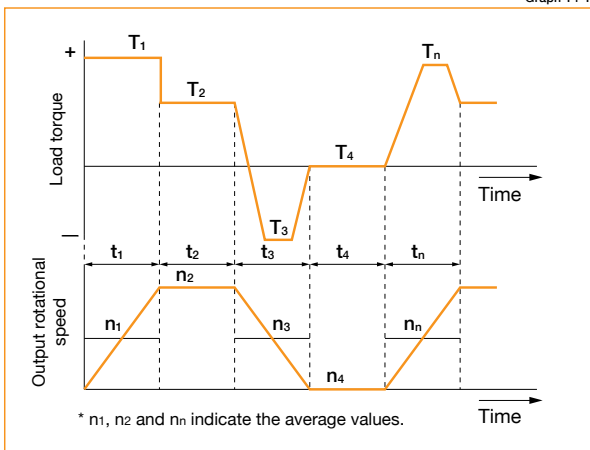

Obtain the value of each application motion profile.	
Load torque	T_n (Nm)
Time	t_n (sec)
Output rotational speed	n_n (rpm)
Normal operation pattern	
Starting (acceleration)	T_1, t_1, n_1
Steady operation (constant velocity)	T_2, t_2, n_2
Stopping (deceleration)	T_3, t_3, n_3
Dwell	T_4, t_4, n_4
Maximum rotational speed	
Max. output speed	no_{max}
Max. input rotational speed (Restricted by motors)	ni_{max}
Emergency stop torque	
When impact torque is applied	T_s, t_s, n_s
Required life	
	$L_{10} = L$ (hours)

■ Flowchart for selecting a size

Please use the flowchart shown below for selecting a size. Operating conditions must not exceed the performance ratings.

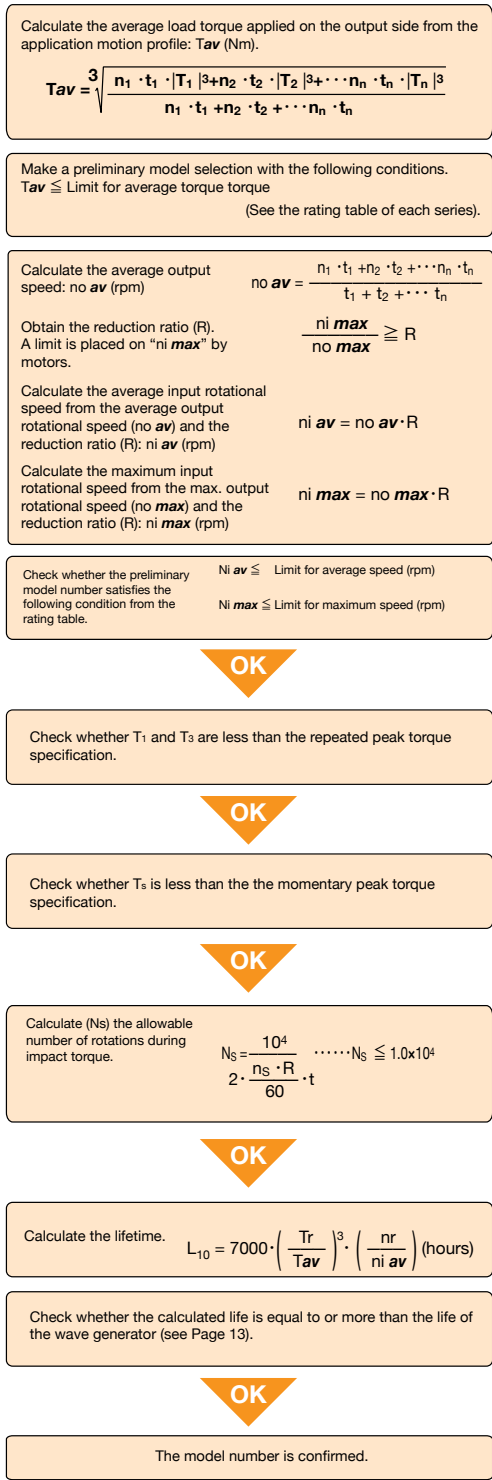

Example of model number selection

Value of each application motion profile		Maximum rotational speed	
Load torque	T_n (Nm)	Max. output speed	no <i>max</i> = 14 rpm
Time	t_n (sec)	Max. input speed	ni <i>max</i> = 1800 rpm
Output speed	n_n (rpm)	(Restricted by motors)	
Normal operation pattern		Emergency stop torque	
Starting (acceleration)	T1 = 400 Nm, t1 = 0.3sec, n1 = 7rpm	When impact torque is applied	Ts = 500 Nm, ts = 0.15 sec, ns = 14 rpm
Steady operation (constant velocity)	T2 = 320 Nm, t2 = 3sec, n2 = 14rpm		
Stopping (deceleration)	T3 = 200 Nm, t3 = 0.4sec, n3 = 7rpm	Required life	L10 = 7000 (hours)
Dwell	T4 = 0 Nm, t4 = 0.2 sec, n4 = 0 rpm		

Calculate the average load torque to the output side based on the application motion profile: T_{av} (Nm).

$$T_{av} = 3 \sqrt{\frac{7 \text{ rpm} \cdot 0.3 \text{ sec} \cdot |400 \text{ Nm}|^3 + 14 \text{ rpm} \cdot 3 \text{ sec} \cdot |320 \text{ Nm}|^3 + 7 \text{ rpm} \cdot 0.4 \text{ sec} \cdot |200 \text{ Nm}|^3}{7 \text{ rpm} \cdot 0.3 \text{ sec} + 14 \text{ rpm} \cdot 3 \text{ sec} + 7 \text{ rpm} \cdot 0.4 \text{ sec}}}$$

Make a preliminary model selection with the following conditions. $T_{av} = 319 \text{ Nm} \leq 620 \text{ Nm}$
 (Limit for average torque for model number CSF-40-120-2A-GR: See the rating table on Page 39.)
 Thus, **CSF-40-120-2A-GR** is tentatively selected.

Calculate the average output rotational speed: no av (rpm) $no \text{ } av = \frac{7 \text{ rpm} \cdot 0.3 \text{ sec} + 14 \text{ rpm} \cdot 3 \text{ sec} + 7 \text{ rpm} \cdot 0.4 \text{ sec}}{0.3 \text{ sec} + 3 \text{ sec} + 0.4 \text{ sec} + 0.2 \text{ sec}} = 12 \text{ rpm}$

Obtain the reduction ratio (R). $\frac{1800 \text{ rpm}}{14 \text{ rpm}} = 128.6 \geq 120$

Calculate the average input rotational speed from the average output rotational speed (no av) and the reduction ratio (R): ni av (rpm) $ni \text{ } av = 12 \text{ rpm} \cdot 120 = 1440 \text{ rpm}$

Calculate the maximum input rotational speed from the maximum output rotational speed (no max) and the reduction ratio (R): ni max (rpm) $ni \text{ } max = 14 \text{ rpm} \cdot 120 = 1680 \text{ rpm}$

Check whether the preliminary selected model number satisfies the following condition from the rating table. **NG**

OK

$Ni \text{ } av = 1440 \text{ rpm} \leq 3600 \text{ rpm}$ (Max average input speed of size 40)
 $Ni \text{ } max = 1680 \text{ rpm} \leq 5600 \text{ rpm}$ (Max input speed of size 40)

Check whether T1 and T3 are equal to or less than the repeated peak torque specification. **NG**

OK

$T1 = 400 \text{ Nm} \leq 617 \text{ Nm}$ (Limit of repeated peak torque of size 40)
 $T3 = 200 \text{ Nm} \leq 617 \text{ Nm}$ (Limit of repeated peak torque of size 40)

Check whether Ts is equal to or less than the momentary peak torque specification. **NG**

OK

$Ts = 500 \text{ Nm} \leq 1180 \text{ Nm}$ (Limit for momentary torque of size 40)

Calculate the allowable number (Ns) rotation during impact torque and confirm $\leq 1.0 \times 10^4$ **NG**

OK

$$N_s = \frac{10^4}{2 \cdot \frac{14 \text{ rpm} \cdot 120}{60} \cdot 0.15 \text{ sec}} = 1190 \leq 1.0 \times 10^4$$

Calculate the lifetime. **NG**

$$L_{10} = 7000 \cdot \left(\frac{294 \text{ Nm}}{319 \text{ Nm}} \right)^3 \cdot \left(\frac{2000 \text{ rpm}}{1440 \text{ rpm}} \right) \text{ (hours)}$$

Check whether the calculated life is equal to or more than the life of the wave generator (see Page 12). **NG**

OK

$L_{10} = 7610 \text{ hours} \geq 7000$ (life of the wave generator: L10)

The selection of model number **CSF-40-120-2A-GR** is confirmed from the above calculations.

Review the operation conditions, size and reduction ratio

Lubrication

Component Sets: CSD-2A, CSF-2A, CSG-2A, FB-2, FB-0, FR-2, SHF-2A, SHG-2A and SHD and SHG/SHF -2SO and -2SH gear units: Grease lubricant and oil lubricant are available for lubricating the component sets and SHD gear unit. It is extremely important to properly grease your component sets and SHD gear unit. Proper lubrication is essential for high performance and reliability. Harmonic Drive® component sets are shipped with a rust- preventative oil. The characteristics of the lubricating grease and oil types approved by Harmonic Drive are not changed by mixing with the preservation oil. It is therefore not necessary to remove the preservation oil completely from the gear components. However, the mating surfaces must be degreased before the assembly.

Gear Units: CSG/CSF 2UH and 2UH-LW; CSD-2UF and -2UH; SHG/SHF-2UH and 2UH- LW; SHG/SHF-2UJ; CSF Supermini, CSF Mini, and CSF-2UP.

Grease lubricant is standard for lubricating the gear units. You do not need to apply grease during assembly as the product is lubricated and shipped.

See Page 19 for using lubricant beyond the temperature range in table 16-2.

* Contact us if you want consistency zero (NLGI No.0) for maintenance reasons.

Grease lubricant

Types of lubricant

Harmonic Grease® SK-1A

This grease was developed for Harmonic Drive® gears and features good durability and efficiency.

Harmonic Grease® SK-2

This grease was developed for small sized Harmonic Drive® gears and features smooth rotation of the Wave Generator since high pressure additive is liquefied.

Harmonic Grease® 4B No.2

This has been developed exclusively for the CSF and CSG and features long life and can be used over a wide range of temperature.

(Note)

- Grease lubrication must have proper sealing, this is essential for 4B No.2. Rotating part: Oil seal with spring is needed. Mating part: O ring or seal adhesive is needed.
- The grease has the highest deterioration rate in the region where the grease is subjected to the greatest shear (near wave generator). Its viscosity is between JIS No.0 and No.00 depending on the operation.

Table 016-3

NLGI consistency No.	Mixing consistency range
0	355 to 385
00	400 to 430

Grease specification

Table 016-4

Grease	SK-1A	SK-2	4B No.2
Base oil	Refined oil	Refined oil	Composite hydrocarbon oil
Base Viscosity cSt (25°C)	265 to 295	265 to 295	290 to 320
Thickening agent	Lithium soap base	Lithium soap base	Urea
NLGI consistency No.	No. 2	No. 2	No. 1.5
Additive	Extreme-pressure additive, others	Extreme-pressure additive, others	Extreme-pressure additive, others
Drop Point	197°C	198°C	247°C
Appearance	Yellow	Green	Light yellow
Storage life	5 years in sealed condition	5 years in sealed condition	5 years in sealed condition

Name of lubricant

Table 016-1

Grease	Harmonic Grease® SK-1A
	Harmonic Grease® SK-2
	Harmonic Grease® 4B No.2
Oil	Industrial gear oil class-2 (extreme pressure) ISO VG68

Temperature

Table 016-2

Grease	SK-1A 0°C to + 40°C
	SK-2 0°C to + 40°C
	4B No.2 -10°C to + 70°C
Oil	ISO VG68 0°C to + 40°C

* The hottest section should not be more than 40° above the ambient temperature.

Note: The three basic components of the gear - the Flexspline, Wave Generator and Circular Spline - are matched and serialized in the factory. Depending on the product they are either greased or prepared with preservation oil. Then the individual components are assembled. If you receive several units, please be careful not to mix the matched components. This can be avoided by verifying that the serial numbers of the assembled gear components are identical.

Compatible grease by size

Compatible grease varies depending on the size and reduction ratio. See the following compatibility table. We recommend SK-1A and SK-2 for general use.

Ratios 30:1

Table 016-5

Size	8	11	14	17	20	25	32
SK-1A	—	—	—	—	○	○	○
SK-2	○	○	○	○	—	—	—
4B No.2	△	△	△	△	□	□	□

Ratios 50:1* and above

Table 016-6

Size	8	11	14	17	20	25	32
SK-1A	—	—	—	—	○	○	○
SK-2	○	○	○	○	△	△	△
4B No.2	—	—	□	□	□	□	□

Size	40	45	50	58	65	80	90	100
SK-1A	○	○	○	○	○	○	○	○
SK-2	△	—	—	—	—	—	—	—
4B No.2	□	□	□	□	□	□	□	□

○: Standard grease

△: Semi-standard grease

□: Recommended grease for long life and high load

* Oil lubrication is required for component-sets size 50 or larger with a reduction ratio of 50:1.

Grease characteristics

Table 016-7

Grease	SK-1A	SK-2	4B No.2
Durability	○	○	◎
Fretting resistance	○	○	◎
Low-temperature performance	△	△	◎
Grease leakage	◎	◎	△

Excellent :◎

Good :○

Use Caution :△

When to replace grease

The wear characteristics of the gear are strongly influenced by the condition of the grease lubrication. The condition of the grease is affected by the ambient temperature. The graph 017-1 shows the maximum number of input rotations for various temperatures. This graph applies to applications where the average load torque does not exceed the rated torque.

Note: Recommended Grease: SK-1A or SK-2

When to replace grease: L_{GTn} (when the average load torque is equal to or less than the rated torque)

Graph 017-1

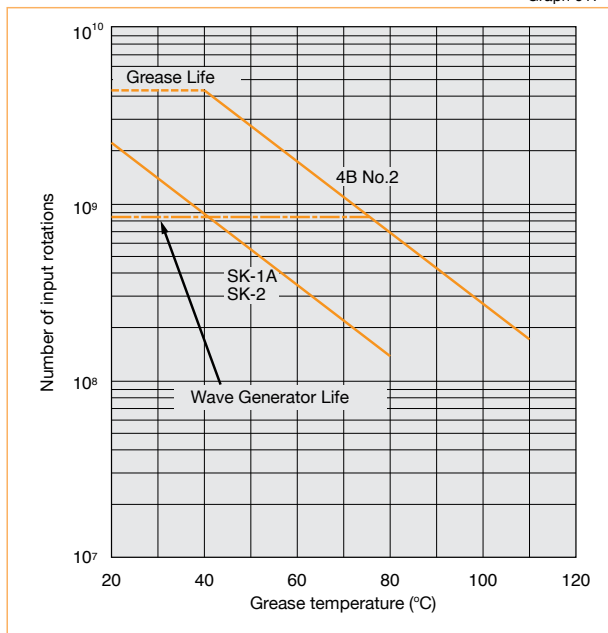

Calculation formula when the average load torque exceeds the rated torque

Formula 017-1

$$L_{GT} = L_{GTn} \times \left(\frac{T_r}{T_{av}} \right)^3$$

Formula Symbols

Table 017-1

L_{GT}	Grease change (if average load torque exceeds rated torque)	input revolutions	_____
L_{GTn}	Grease change (if average load torque is equal to or less than rated torque)	input revolutions (From Graph)	See the Graph 017-1.
T_r	Rated torque	Nm	See the "Ratings Table" of each series.
T_{av}	Average load torque	Nm	Calculation formula: See Page 014.

Other precautions

1. Avoid mixing different kinds of grease. The gear should be in an individual case when installed.
2. Please contact us when you use HarmonicDrive® gears at constant load or in one direction continuously, as it may cause lubrication problems.
3. Grease leakage. A sealed structure is needed to maintain the high durability of the gear and prevent grease leakage.

See the corresponding pages of the design guide of each series for "Recommended minimum housing clearance," "Application guide" and "Application quantity."

Precautions on using Harmonic Grease® 4B No.2

Harmonic Grease® 4B No.2 lubrication is ideally suited for Harmonic Drive® gears.

- (1) Apply the grease to each contacting joint at the beginning of operation.
- (2) Remove any contaminants created by abrasion during running-in period.

■ See the corresponding pages of the design guide of each series for “recommended minimum housing clearance,” Application guide” and “Application quantity.”

■ Precautions

(1) Stir Grease

When storing Harmonic Grease 4B No.2 lubrication in the container, it is common for the oil to weep from the thickener. Before greasing, stir the grease in the container to mix and soften.

(2) Aging (running-in)

The aging before the main operation softens the applied grease. More effective greasing performance can be realized when the grease is distributed around each contact surface.

Therefore, the following aging methods are recommended.

- Keep the internal temperature at 80°C or cooler. Do not start the aging at high temperature rapidly.
- Input rotational speed should be 1000rpm to 3000rpm. However, the lower rotational speed of 1000rpm is more effective. Set the speed as low as possible within the indicated range.
- The time required for aging is 20 minutes or longer.
- Operation range for aging: Keep the output rotational angle as large as possible.

Contact us if you have any questions for handling Harmonic Grease 4B No.2 lubrication.

Note: Strict sealing is required to prevent grease leakage.

Oil lubricant

■ Types of oil

The specified standard lubricant is “Industrial gear oil class-2 (extreme pressure) ISO VG68.” We recommend the following brands as a commercial lubricant.

Table 018-1

Standard	Mobil Oil	Exxon	Shell	COSMO Oil	Japan Energy	NIPPON Oil	Idemitsu Kosan	General Oil	Klüber
Industrial gear oil class-2 (extreme pressure) ISO VG68	Mobilgear 600XP68	Spartan EP68	Omala Oil 68	Cosmo gear SE68	ES gear G68	Bonock M68, Bonock AX68	Daphne super gear LW68	General Oil SP gear roll 68	Syntheso D-68EP

■ When to replace oil

First time 100 hours after starting operation

Second time or after Every 1000 operation hours or every 6 months

Note that you should replace the oil earlier than specified if the operating condition is demanding.

■ See the corresponding pages of the design guide of each series for specific details.

■ Other precautions

1. Avoid mixing different kinds of oil. The gear should be in an individual case when installed.
2. When you use size 50 or above at max allowable input speed, please contact us as it may cause lubrication problems.

* Oil lubrication is required for component-sets size 50 or larger with a reduction ratio of 50:1.

Lubricant for special environments

When the ambient temperature is special (other than the “temperature range of the operating environment” on Page 016-2), you should select a lubricant appropriate for the operating temperature range.

Harmonic Grease 4B No.2

Table 019-1

Type of lubricant	Operating temperature range	Available temperature range
Grease	-10°C to + 110°C	-50°C to + 130°C

Harmonic Grease 4B No.2

The operating temperature range of Harmonic Grease 4B No.2 lubrication is the temperature at the lubricating section with the performance and characteristics of the gear taken into consideration. (It is not ambient temperature.)

High temperature lubricant

Table 019-2

Type of lubricant	Lubricant and manufacturer	Available temperature range
Grease	Mobil grease 28: Mobil Oil	-5°C to + 160°C
Oil	Mobil SHC-626: Mobil Oil	-5°C to + 140°C

As the available temperature range indicates the temperature of the independent lubricant, restriction is added on operating conditions (such as load torque, rotational speed and operating cycle) of the gear. When the ambient temperature is very high or low, materials of the parts of the gear need to be reviewed for suitability. Contact us if operating in high temperature.

Harmonic Grease 4B No.2 can be used in the available temperature range shown in table 019-1. However, input running torque will increase at low temperatures, and grease life will be decreased at high temperatures due to oxidation and lubricant degradation.

Low temperature lubricant

Table 019-3

Type of lubricant	Lubricant and manufacturer	Available temperature range
Grease	Multemp SH-KII: Kyodo Oil	-30°C to + 50°C
	Isoflex LDS-18 special A: KLÜBER	-25°C to + 80°C
Oil	SH-200-100CS: Toray Silicon	-40°C to + 140°C
	Syntheso D-32EP: KLÜBER	-25°C to + 90°C

Torsional Stiffness

Stiffness and backlash of the drive system greatly affects the performance of the servo system. Please perform a detailed review of these items before designing your equipment and selecting a model number.

Stiffness

Fixing the input side (wave generator) and applying torque to the output side (flexspline) generates torsion almost proportional to the torque on the output side. Figure 018-1 shows the torsional angle at the output side when the torque applied on the output side starts from zero, increases up to $+T_0$ and decreases down to $-T_0$. This is called the "Torque – torsion angle diagram," which normally draws a loop of $0 - A - B - A' - B' - A$. The slope described in the "Torque – torsion angle diagram" is represented as the spring constant for the stiffness of the HarmonicDrive® gear (unit: Nm/rad).

As shown in Figure 020-1, this "Torque – torsional angle diagram" is divided into 3 regions, and the spring constants in the area are represented by K_1 , K_2 and K_3 .

K_1 ... The spring constant when the torque changes from [zero] to $[T_1]$

K_2 ... The spring constant when the torque changes from $[T_1]$ to $[T_2]$

K_3 ... The spring constant when the torque changes from $[T_2]$ to $[T_3]$

See the corresponding pages of each series for values of the spring constants (K_1 , K_2 , K_3) and the torque-torsional angles (T_1 , T_2 , $-\theta_1$, θ_2).

Example for calculating the torsion angle

The torsion angle (θ) is calculated here using CSF-25-100-2A-GR as an example.

When the applied torque is T_1 or less, the torsion angle θ_{L1} is calculated as follows:

$$\begin{aligned}\theta_{L1} &= T_{L1}/K_1 \\ &= 2.9/3.1 \times 10^4 \\ &= 9.4 \times 10^{-5} \text{ rad (0.33 arc min)}\end{aligned}$$

When the applied torque is between T_1 and T_2 , the torsion angle θ_{L2} is calculated as follows:

$$\begin{aligned}\theta_{L2} &= \theta_1 + (T_{L2} - T_1)/K_2 \\ &= 4.4 \times 10^{-4} + (39 - 14)/5.0 \times 10^4 \\ &= 9.4 \times 10^{-4} \text{ rad (3.2 arc min)}\end{aligned}$$

When a bidirectional load is applied, the total torsion angle will be $2 \times \theta_{Lx}$ plus hysteresis loss.

* The torsion angle calculation is for the gear component set only and does not include any torsional windup of the output shaft.

Note: See p.120 for torsional stiffness for pancake gearing .

Hysteresis loss (Silk hat and cup style only)

As shown in Figure 020-1, when the applied torque is increased to the rated torque and is brought back to [zero], the torsional angle does not return exactly to the zero point. This small difference ($B - B'$) is called hysteresis loss.

See the corresponding page of each series for the hysteresis loss value.

Torque - torsion angle diagram

Figure 20-1

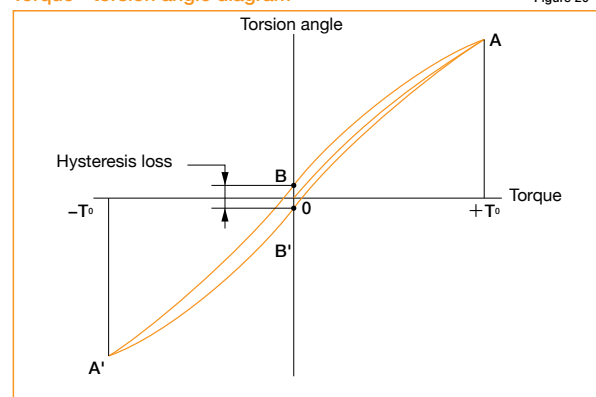

Spring constant diagram

Figure 20-2

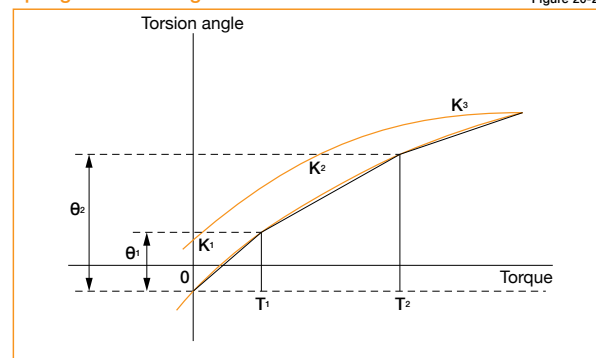

Backlash (Silk hat and cup style only)

Hysteresis loss is primarily caused by internal friction. It is a very small value and will vary roughly in proportion to the applied load. Because HarmonicDrive® gears have zero backlash, the only true backlash is due to the clearance in the Oldham coupling, a self-aligning mechanism used on the wave generator. Since the Oldham coupling is used on the input, the backlash measured at the output is extremely small (arc-seconds) since it is divided by the gear reduction ratio.

Positional Accuracy

Positional Accuracy values represent the difference between the theoretical angle and the actual angle of output for any given input. The values shown in the table are maximum values.

■ See the corresponding pages of each series for transmission accuracy values.

Example of measurement

Graph 021-1

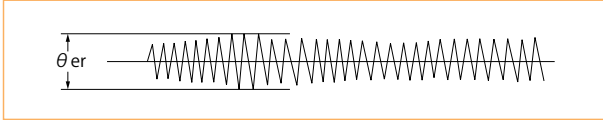

Table 021-1

θ_{er}	Transmission accuracy
θ_1	Input angle
θ_2	Actual output angle
R	Reduction ratio

Formula 021-1

$$\theta_{er} = \theta_2 - \frac{\theta_1}{R}$$

Vibration

The primary frequency of the transmission error of the HarmonicDrive® gear may cause a vibration of the load inertia. This can occur when the driving frequency of the servo system including the HarmonicDrive® gear is at, or close to the resonant frequency of the system. Refer to the design guide of each series.

The primary component of the transmission error occurs twice per input revolution of the input. Therefore, the frequency generated by the transmission error is 2x the input frequency (rev / sec).

If the resonant frequency of the entire system, including the HarmonicDrive® gear, is F=15 Hz, then the input speed (N) which would generate that frequency could be calculated with the formula below.

Formula 021-2

$$N = \frac{15}{2} \cdot 60 = 450 \text{ rpm}$$

The resonant frequency is generated at an input speed of 450 rpm.

How to the calculate resonant frequency of the system

Formula 021-3

$$f = \frac{1}{2\pi} \sqrt{\frac{K}{J}}$$

Formula variables

Table 021-2

f	The resonant frequency of the system	Hz	
K	Spring constant	Nm/rad	See pages of each series
J	Load inertia	kgm ²	

Starting Torque

Starting torque is the torque value applied to the input side at which the output first starts to rotate. The values in the table of each series indicate the maximum value, and the lower-limit value indicates approximately $\frac{1}{2}$ to $\frac{1}{3}$ of the maximum value.

Measurement conditions:

No-load, ambient temperature: +20°C _____

■ See the corresponding pages of each series for starting torque values.

* Use the values in the table of each series as reference values as they vary depending on the usage conditions.

Backdriving Torque

Backdriving torque is the torque value applied to the output side at which the input first starts to rotate. The values in the table are maximum values, typical values are approximately $\frac{1}{2}$ of the maximum values.

Note: Never rely on these values as a margin in a system that must hold an external load. A brake must be used where back driving is not permissible.

Measurement conditions:

No-load, ambient temperature: +20°C _____

■ See the corresponding pages of each series for backdriving torque values.

* Use the values in the table of each series as reference values as they vary depending on the usage conditions.

No-Load Running Torque

No-load running torque is the torque which is required to rotate the input side (high speed side), when there is no load on the output side (low speed side). The graph of the no-load running torque shown in this catalog depends on the measurement conditions shown in Table 023-1.

Add the compensation values shown by each series to all reduction ratios except 100:1.

- See the corresponding pages of each series for no-load running torque values.

Measurement condition

Table 023-1

Reduction ratio 100			
Lubricant	Grease lubrication	Name	Harmonic Grease SK-1A
			Harmonic Grease SK-2
		Quantity	(See pages of each series)
Torque value is measured after 2 hours at 2000 rpm input			

* Contact us for oil lubrication.

Efficiency

The efficiency varies depending on the following conditions.

- Reduction ratio
- Input speed
- Load torque
- Temperature
- Lubrication (type and quantity)

The efficiency characteristics of each series shown in this catalog depends on the measurement condition shown in Table 023-2.

- See the corresponding pages of each series for efficiency values.

Efficiency compensation coefficient

If load torque is below rated torque, a compensation factor must be employed. Calculate the compensation coefficient K_e from the efficiency compensation coefficient graph of each series and use the following example for calculation.

Example of calculation

Efficiency η (%) under the following condition is obtained from the example of CSF-20-80-2A-GR.

Input rotational speed: 1000 rpm

Load torque: 19.6 Nm

Lubrication method: Grease lubrication (Harmonic Grease SK-1A)

Lubricant temperature: 20°C

Since the rated torque of size 20 with a reduction ratio of 80 is 34 Nm (Ratings: Page 039), the torque ratio α is 0.58.

($\alpha=19.6/34=0.58$)

- The efficiency compensation coefficient is $K_e=0.93$ from Graph 023-1.
- Efficiency η at load torque 19.6 Nm: $\eta=K_e \cdot \eta_R=0.93 \times 78=73\%$

Measurement condition

Table 023-2

Installation	Based on recommended tolerance		
Load torque	The rated torque shown in the rating table (see the corresponding pages on each series)		
Lubricant	Grease lubrication	Name	Harmonic Grease SK-1A
			Harmonic Grease SK-2
		Quantity	Recommended quantity (see the pages on each series)

* Contact us for oil lubrication.

Efficiency compensation coefficient (CSF series)

Graph 023-1

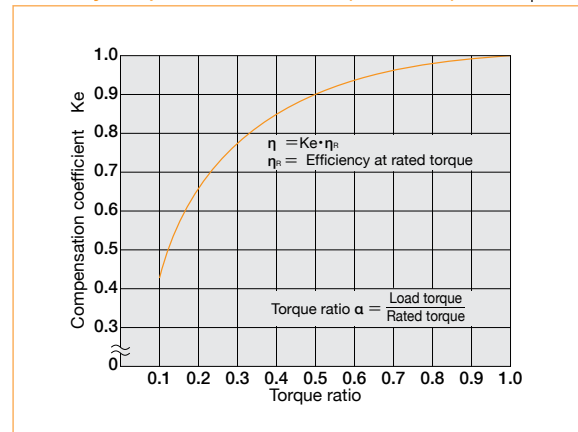

* Efficiency compensation coefficient $K_e=1$ when the load torque is greater than the rated torque.

Design Guidelines

Design guideline

The relative perpendicularity and concentricity of the three basic Harmonic Drive® elements have an important influence on accuracy and service life.

Misalignments will adversely affect performance and reliability. Compliance with recommended assembly tolerances is essential in order for the advantages of Harmonic Drive® gearing to be fully realized. Please consider the following when designing:

- (1) Input shaft, Circular Spline and housing must be concentric.
- (2) When operating, an axial force is generated on the wave generator. Input bearings must be selected to accommodate this axial load. See page 27.
- (3) Even though a HarmonicDrive® gear is compact, it transmits large torques. Therefore, assure that all required bolts are used to fastened the circular spline and flexspline and that they are tightened to the recommended torque.
- (4) As the flexspline is subject to elastic deformation, the A minimal clearance between the flexspline and housing is required. Refer to "Minimum Housing Clearance" on the drawing dimension tables.
- (5) The input shaft and output shaft are supported by anti-friction bearings. As the wave generator and flexspline elements are meant to transmit pure torque only, the bearing arrangement needs to isolate the harmonic gearing from external forces applied to either shaft. A common bearing arrangement is depicted in the diagram.
- (6) A clamping plate is recommended (item 6). Its purpose is to spread fastening forces and to avoid any chance of making physical contact with the thin section of the flexspline diaphragm. The clamping plate shall not exceed the diaphragm's boss diameter and is to be designed in accordance with catalog recommendations.

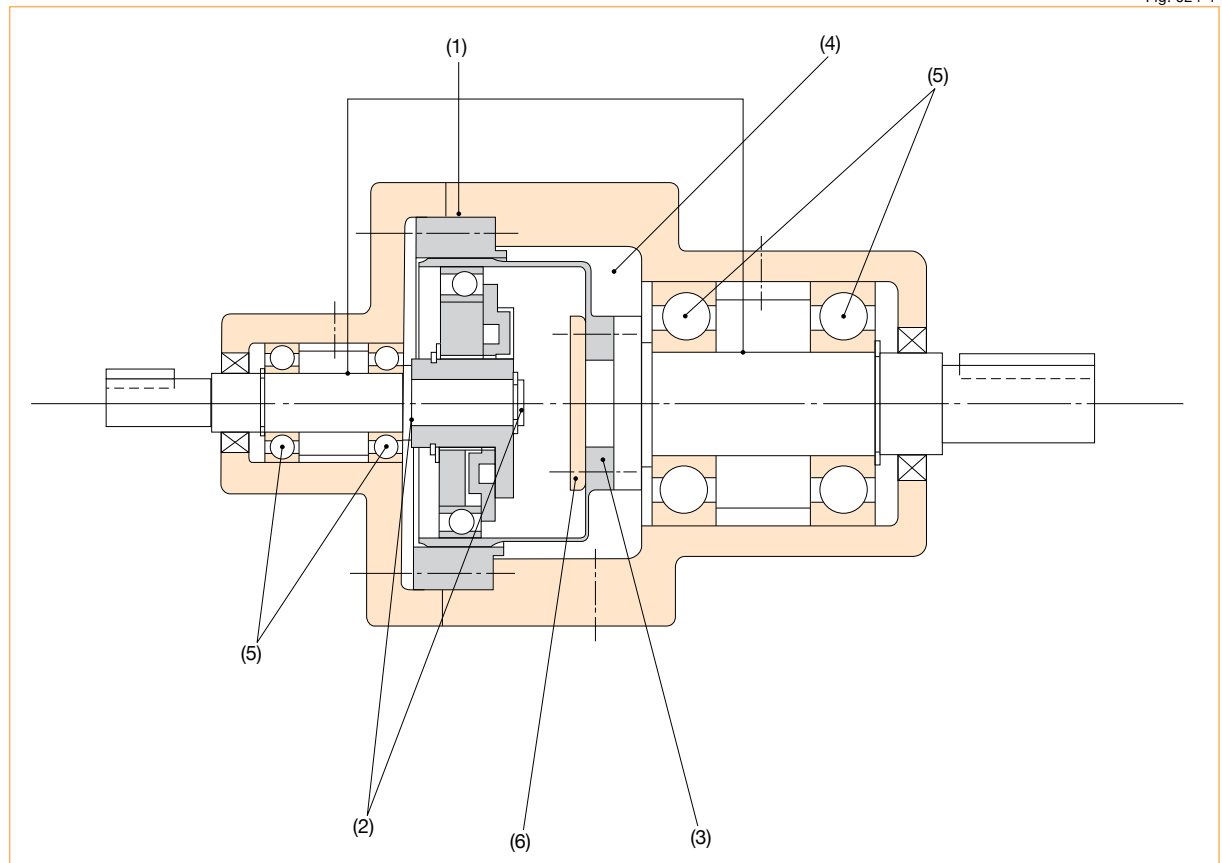

Bearing support for the input and output shafts

For the component sets, both input and output shafts must be supported by two adequately spaced bearings in order to withstand external radial and axial forces without excessive deflection. In order to avoid damage to the component set when limited external loads are anticipated, both input and output shafts must be axially fixed.

Bearings must be selected whose radial play does not exceed ISO-standard C 2 class or "normal" class. The bearings should be axially and radially preloaded to eliminate backlash.

Examples of correct bearing arrangements are shown in fig 025-1.

Fig. 025-1

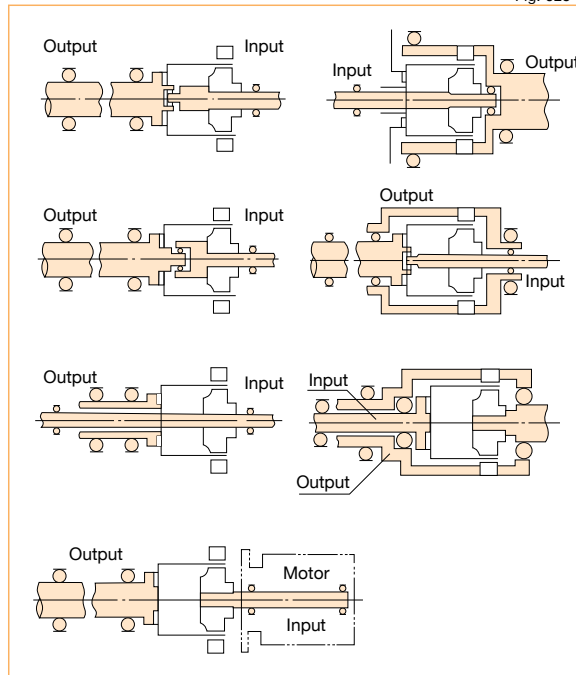

Wave generator

■ Structure of the wave generator

The wave generator includes an Oldham's coupling type with a self-aligning structure and an integrated solid wave generator without a self-aligning structure, and which is used depends on the series.

See the diagram of each series for details. The basic structure of the wave generator and the shape are shown below.

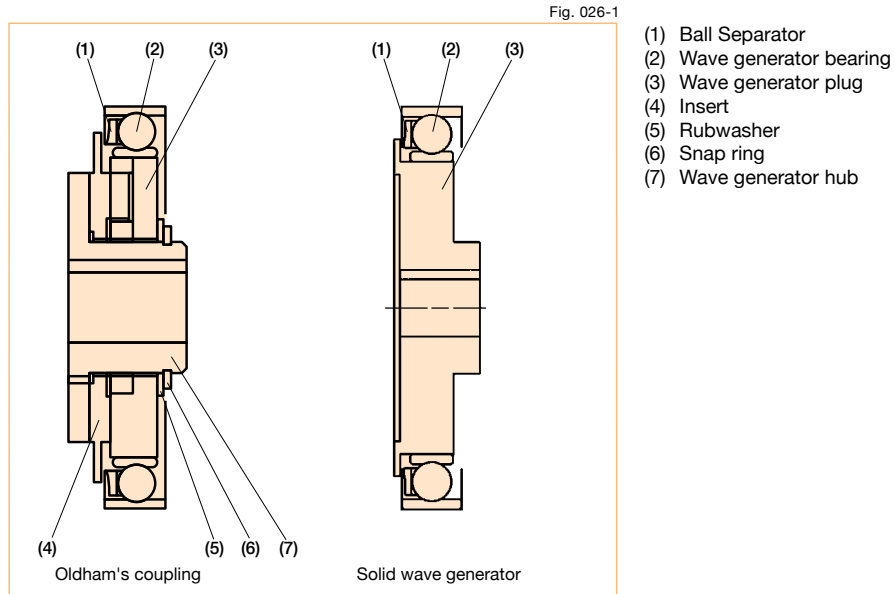

Structure of Oldham's coupling

Fig. 026-2

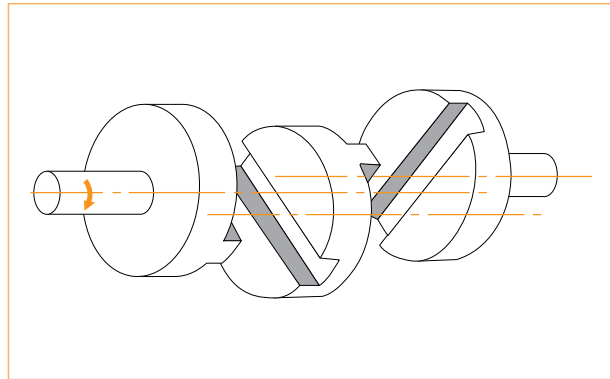

Maximum hole diameter of wave generator

The standard hole dimension of the wave generator is shown for each size. The dimension can be changed within a range up to the maximum hole dimension. We recommend the dimension of keyway based on JIS standard. It is necessary that the dimension of keyways should sustain the transmission torque.

* Tapered holes are also available.

In cases where a larger hole is required, use the wave generator without the Oldham coupling. The maximum diameter of the hole should be considered to prevent deformation of the Wave Generator plug by load torque. The dimension is shown in the table below and includes the dimension of depth of keyway. (This is the value including the dimension of the depth of keyway.)

Hole diameter of the wave generator

Fig. 027-1

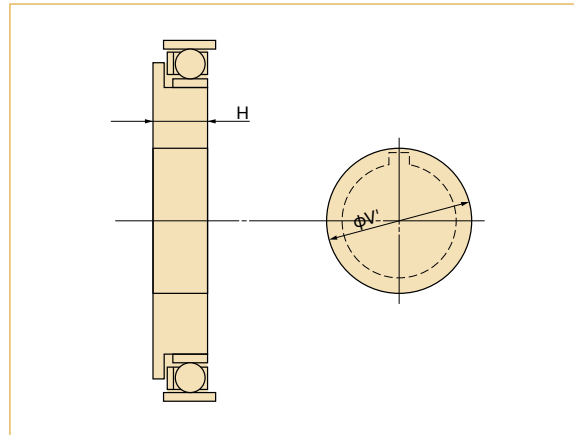

Hole diameter of the wave generator hub with Oldham coupling

Table 027-1
Unit: mm

Size	8	11	14	17	20	25	32	40	45	50	58	65	80	90	100
Standard dim. (H7)	3	5	6	8	9	11	14	14	19	19	22	24	28	28	28
Minimum hole dim.	—	—	3	4	5	6	6	10	10	10	13	16	16	19	22
Maximum hole dim.	—	—	8	10	13	15	15	20	20	20	25	30	35	37	40

Maximum hole diameter without Oldham Coupling

Table 027-2
Unit: mm

Size	8	11	14	17	20	25	32	40	45	50	58	65	80	90	100
Max. hole dia. φV'	10	14	17	20	23	28	36	42	47	52	60	67	72	84	95
Min. plug thick. H _{8/g₇}	5.7	6.7	7.2	7.6	11.3	11.3	13.7	15.9	17.8	19	21.4	23.5	28.5	31.3	34.9

Axial Force of Wave Generator

When the gear is used to accelerate a load, the deflection of the Flexspline leads to an axial force acting on the Wave Generator. This axial force, which acts in the direction of the closed end of the Flexspline, must be supported by the bearings of the input shaft (motor shaft). When the gear is used to decelerate a load, an axial force acts to push the Wave Generator out of the Flexspline cup. Maximum axial force of the Wave Generator can be calculated by the equation shown below. The axial force may vary depending on its operating condition. The value of axial force tends to be a larger number when using high torque, extreme low speed and constant operation. The force is calculated (approximately) by the equation. In all cases, the Wave Generator must be axially (in both directions), as well as torsionally, fixed to the input shaft.

(Note)
Please contact us for further information on attaching the Wave Generator to the input (motor) shaft.

Axial force direction of the wave generator

Fig. 027-2

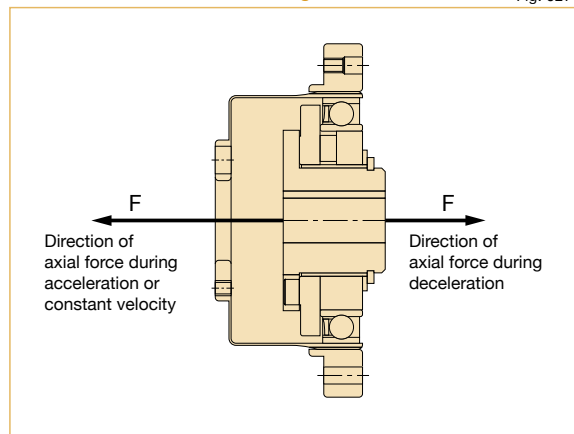

Formula for Axial Force

Table 027-3

Reduction ratio	Calculation formula
30	$F = 2 \times \frac{T}{D} \times 0.07 \times \tan 32^\circ$
50	$F = 2 \times \frac{T}{D} \times 0.07 \times \tan 30^\circ$
80 or more	$F = 2 \times \frac{T}{D} \times 0.07 \times \tan 20^\circ$

Symbols for Formula

Table 027-4

F	Axial force	N	See Figure 027-2
D	Size	m	
T	Output torque	Nm	

Calculation example

Formula 027-1

Model name: CSF series
 Size: 32
 Reduction ratio: 50
 Output torque: 382 Nm
 (maximum allowable momentary torque)

$$F = 2 \times \frac{382}{(32 \times 0.00254)} \times 0.07 \times \tan 30^\circ$$

F = 380N

Assembly Precautions

Sealing

Sealing is needed to maintain the high durability of the gear and prevent grease leakage. Recommended for all mating surfaces, if the o-ring is not used. Flanges provided with o-ring grooves must be sealed when a proper seal cannot be achieved using the o-ring alone.

- Rotating Parts Oil seal with spring is needed.
- Mating flange O-ring or seal adhesive is needed.
- Screw hole area Screws should have a thread lock (LOCTITE® 242 is recommended) or seal adhesive.

(Note) If you use Harmonic Grease 4BNo.2, strict sealing is required.

Sealing recommendations for gear units

Table 028-1

Area requiring sealing		Recommended sealing method
Output side	Holes which penetrate housing	Use O-ring (supplied with the product)
	Installation screw / bolt	Screw lock adhesive which has effective seal (LOCTITE® 242 is recommended)
Input side	Flange surfaces	Use O-ring (supplied with the product)
	Motor output shaft	Please select a motor which has an oil seal on the output shaft.

Assembly precautions

The wave generator is installed after the flexspline and circular spline. If the wave generator is not inserted into the flexspline last, gear teeth scuffing damage or improper eccentric gear mesh may result. Installation resulting in an eccentric tooth mesh (Dedoidal) will cause noise and vibration, and can lead to early failure of the gear. For proper function, the teeth of the flexspline and Circular Spline mesh symmetrically.

■ Precautions on the wave generator

1. Avoid applying undue axial force to the wave generator during installation. Rotating the wave generator bearing while inserting it is recommended and will ease the process.
2. If the wave generator does not have an Oldham coupling, extra care must be given to ensure that concentricity and inclination are within the specified limits

■ Precautions on the circular spline

The circular Spline must not be deformed in any way during the assembly. It is particularly important that the mounting surfaces are prepared correctly

1. Mounting surfaces need to have adequate flatness, smoothness, and no distortion.
2. Especially in the area of the screw holes, burrs or foreign matter should not be present.
3. Adequate relief in the housing corners is needed to prevent interference with the corner of the circular spline.
4. The circular spline should be rotatable within the housing. Be sure there is not interference and that it does not catch on anything.
5. When a bolt is inserted into a bolt hole during installation, make sure that the bolt fits securely and is not in an improper position or inclination.
6. Do not apply torque at recommended torque all at once. First, apply torque at about half of the recommended value to all bolts, then tighten at recommended torque. Order of tightening bolts must be diagonal.
7. Avoid pinning the circular spline if possible as it can reduce the rotational precision and smoothness of operation.

■ Precautions on the flexspline

1. Mounting surfaces need to have adequate flatness, smoothness, and no distortion.
2. Especially in the area of the screw holes, burrs or foreign matter should not be present.
3. Adequate clearance with the housing is needed to ensure no interference especially with the major axis of flexspline
4. Bolts should rotate freely when installing through the mounting holes of the flexspline and should not have any irregularity due to the shaft bolt holes being misaligned or oblique.
5. Do not tighten the bolts with the specified torque all at once. Tighten the bolts temporarily with about half the specified torque, and then tighten them to the specified torque. Tighten them in an even, crisscross pattern.
6. The flexspline and circular spline are concentric after assembly. After installing the wave generator bearing, if it rotates in unbalanced way, check the mounting for dedoidal or non-concentric installation.
7. Care should be taken not to damage the flexspline diaphragm or gear teeth during assembly.
Avoid hitting the tips of the flexpline teeth and circular spline teeth. Avoid installing the CS from the open side of the flexspline after the wave generator has been installed.

■ Rust prevention

Although the Harmonic Drive® gears come with some corrosion protection, the gear can rust if exposed to the environment. The gear external surfaces typically have only a temporary corrosion inhibitor and some oil applied. If an anti-rust product is needed, please contact us to review the options.

"Dedoidal" state

It is normal for the flexspline to engage with the circular spline symmetrically as shown in Figure 029-1. However, if the ratcheting phenomenon, which is described on Page 013, is caused or if the three parts are forcibly inserted and assembled, engagement of the teeth may be out of alignment as shown in Figure 029-2. This is called "dedoidal". Note: Early failure of the gear will occur.

■ How to check "dedoidal"

By performing the following methods, check whether the gear engagement is "dedoidal".

(1) Judging by the irregular torque generated when the wave generator turns

- 1) Slowly turn the input shaft with your hand in a no-load condition. If you can turn it with average force, it is normal. If it turns irregularly, it may be "dedoidal".
- 2) Turn the wave generator in a no-load condition if it is attached to a motor. If the average current value of the motor is about 2 to 3 times the normal value, it may be "dedoidal".

(2) Judging by measuring vibration on the body of the flexspline

The scale deflection of the dial gauge draws a sine wave as shown by the solid line in Graph 029-3 when it is normally assembled. When "dedoidal" occurs, the gauge draws a deflected wave shown by the dotted line as the flexspline is out of alignment.

Normal engagement status

Fig. 029-1

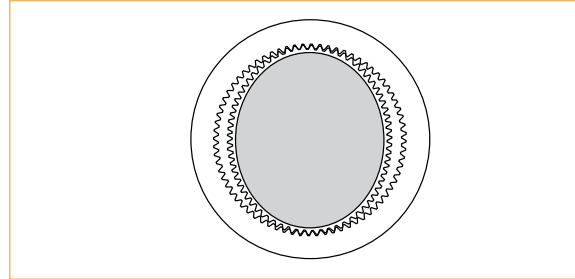

"Dedoidal" status

Fig. 029-2

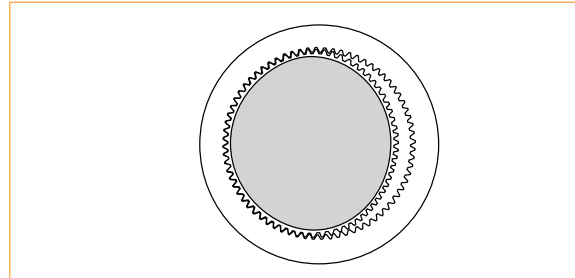

Deflection of the dial gauge

Graph 029-3

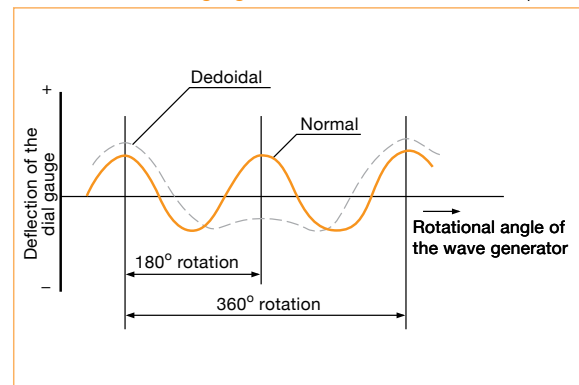

Measuring the deflection on the body of the flexspline

Fig. 029-4

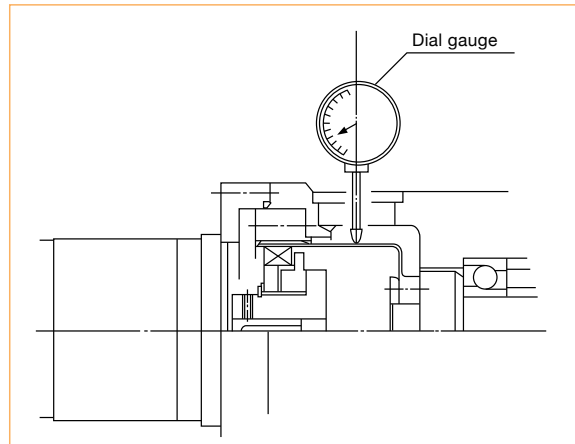

Checking Output Bearing

A precision cross roller bearing is built in the unit type and the gear head type to directly support the external load (output flange) (precision 4-point contact ball bearing for the CSF-mini series). Please calculate maximum moment load, life of cross roller bearing, and static safety factor to fully maximize the performance of a housed unit (gearhead).

- See the corresponding pages on each series for cross roller bearing specifications.

Checking procedure

(1) Checking the maximum moment load (M_{max})

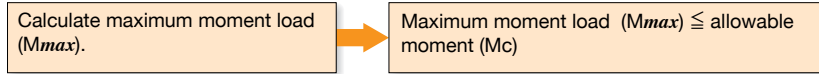

(2) Checking the life

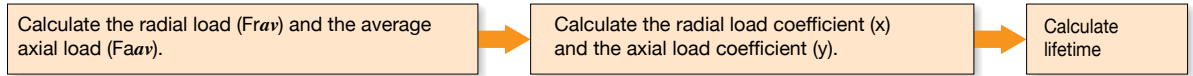

(3) Checking the static safety coefficient



How to calculate the maximum moment load

Maximum moment load (M_{max}) is obtained as follows. Make sure that $M_{max} \leq Mc$.

Formula 030-1

$$M_{max} = Fr_{max} (L_r + R) + Fa_{max} \cdot L_a$$

Symbols for Formula 030-1

Table 030-1

Fr_{max}	Max. radial load	N(kgf)	See Fig. 030-1.
Fa_{max}	Max. axial load	N(kgf)	See Fig. 030-1.
L_r, L_a	—	m	See Fig. 030-1.
R	Offset amount	m	See Fig. 030-1 and "Specification of the output bearing" of each series.

External load influence diagram

Fig. 030-1

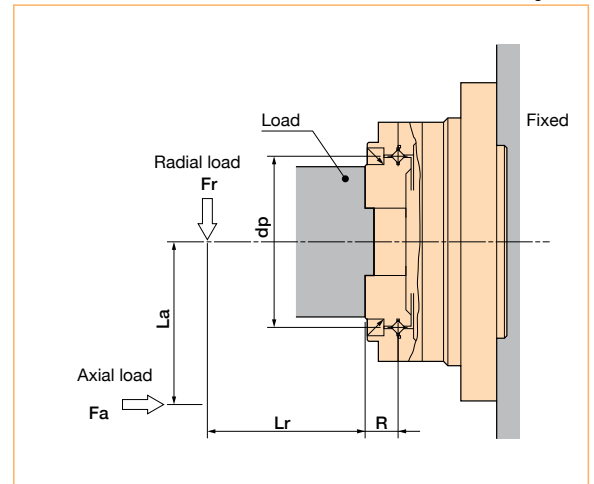

How to calculate the average load

(Average radial load, average axial load, average output speed)

When the radial load and axial load vary, the life of cross roller bearing can be determined by converting to an average load.

How to calculate the average radial load (F_{rav})

Formula 031-1

(Cross roller bearing)

$$F_{rav} = \sqrt[10/3]{\frac{n_1 t_1 (IF_{r1})^{10/3} + n_2 t_2 (IF_{r2})^{10/3} \dots + n_n t_n (IF_{rn})^{10/3}}{n_1 t_1 + n_2 t_2 \dots + n_n t_n}}$$

(4-point contact ball bearing)

$$F_{rav} = \sqrt[3]{\frac{n_1 t_1 (IF_{r1})^3 + n_2 t_2 (IF_{r2})^3 \dots + n_n t_n (IF_{rn})^3}{n_1 t_1 + n_2 t_2 \dots + n_n t_n}}$$

Note that the maximum radial load in t_1 is F_{r1} and the maximum radial load in t_n is F_{rn} .

How to calculate the average axial load (F_{aav})

Formula 031-2

(Cross roller bearing)

$$F_{aav} = \sqrt[10/3]{\frac{n_1 t_1 (IF_{a1})^{10/3} + n_2 t_2 (IF_{a2})^{10/3} \dots + n_n t_n (IF_{an})^{10/3}}{n_1 t_1 + n_2 t_2 \dots + n_n t_n}}$$

(4-point contact ball bearing)

$$F_{aav} = \sqrt[3]{\frac{n_1 t_1 (IF_{a1})^3 + n_2 t_2 (IF_{a2})^3 \dots + n_n t_n (IF_{an})^3}{n_1 t_1 + n_2 t_2 \dots + n_n t_n}}$$

Note that the maximum axial load in t_1 is F_{a1} and the maximum axial load in t_n is F_{an} .

How to calculate the average output speed (N_{av})

Formula 031-3

$$N_{av} = \frac{n_1 t_1 + n_2 t_2 \dots + n_n t_n}{t_1 + t_2 \dots + t_n}$$

Graph 031-1

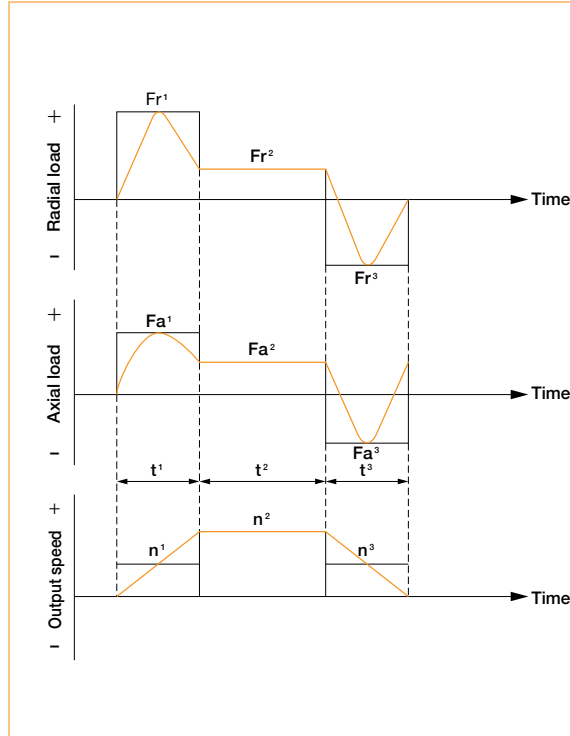

How to calculate the radial load coefficient (X) and axial load coefficient (Y)

Formula 031-4

How to calculate the load coefficient	X	Y
$\frac{F_{aav}}{F_{rav} + 2(F_{rav}(L_r + R) + F_{rav} \cdot L_a) / dp} \leq 1.5$	1	0.45
$\frac{F_{aav}}{F_{rav} + 2(F_{rav}(L_r + R) + F_{rav} \cdot L_a) / dp} > 1.5$	0.67	0.67

Symbols for Formula 031-4

Table 031-1

Symbol	Description	Unit	Reference
F_{rav}	Average radial load	N(kgf)	See "How to calculate the average load." See Formula 031-1.
F_{aav}	Average axial load	N(kgf)	See "How to calculate the average load." See Formula 031-2.
L_r, L_a	_____	m	See fig. 030-1
R	Offset amount	m	See Fig. 030-1 and "Main roller bearing specifications" of each series
dp	Pitch circle diameter of a roller	m	See Fig. 030-1 and "Specification of the output bearing" of each series.

Life of the output bearing

Calculate life of the output bearing by Formula 032-1.
You can calculate the dynamic equivalent radial load (Pc) by Formula 032-2.

Formula 032-1

(Cross roller bearing)

$$L_{10} = \frac{10^6}{60 \times N_{av}} \times \left(\frac{C}{f_w \cdot P_c} \right)^{10/3}$$

(4-point contact ball bearing)

$$L_{10} = \frac{10^6}{60 \times N_{av}} \times \left(\frac{C}{f_w \cdot P_c} \right)^3$$

Formula 032-2

$$P_c = X \cdot \left(F_{rav} + \frac{2(F_{rav}(L_r+R) + F_{rav} \cdot L_a)}{d_p} \right) + Y \cdot F_{aav}$$

Symbols for Formula 032-1

Table 032-1

L ₁₀	Life	hour	---
N _{av}	Average output rated load speed	rpm	See "How to calculate the average load."
C	Basic dynamic rated load	N (kgf)	See "Specification of the output bearing" of each series.
P _c	Dynamic equivalent	N (kgf)	See Formula 032-2.
f _w	Load coefficient	--	See Table 032-3.

Symbols for Formula 032-2

Table 032-2

F _{rav}	Average radial load	N (kgf)	See "How to calculate the average load." See Formula 031-1.
F _{aav}	Average axial load	N (kgf)	See "How to calculate the average load." See Formula 031-2.
d _p	Pitch circle diameter	m	See Fig. 030-1 and "Specification of the output bearing" of each series.
X	Radial load coefficient	--	See Formula 031-4.
Y	Axial load coefficient	--	See Formula 031-4.
L _r , L _a	---	m	See Figure 030-1.
R	Offset	m	See Fig. 030-1 and "Specification of the output bearing" of each series.
M _{ave}	Average moment load	Nm	

Load coefficient

Table 032-3

Load status	f _w
Steady operation without impact and vibration	1 to 1.2
Normal operation	1.2 to 1.5
Operation with impact and vibration	1.5 to 3

How to calculate life during oscillating motion

Calculate the life of the cross roller bearing during oscillating motion by Formula 033-1.

Fig. 033-1

Formula 033-1

(Cross roller bearing)

$$Loc = \frac{10^6}{60 \times n1} \times \frac{90}{\theta} \times \left(\frac{C}{fw \cdot Pc} \right)^{10/3}$$

(4-point contact ball bearing)

$$Loc = \frac{10^6}{60 \times n1} \times \frac{90}{\theta} \times \left(\frac{C}{fw \cdot Pc} \right)^3$$

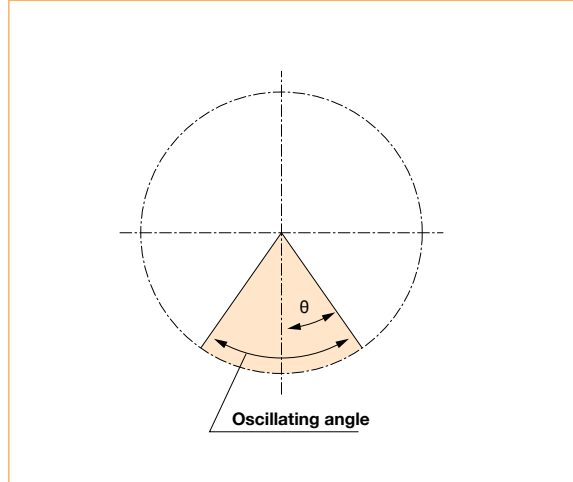

(Note) A small angle of oscillation (less than 5 degrees) may cause fretting corrosion to occur since lubrication may not circulate properly. Contact us if this happens.

Symbols for Formula 033-1

Table 033-1

Loc	Rated life for oscillating motion	hour	---
n1	Round trip oscillation each minute	cpm	---
C	Basic dynamic rated load	N (kgf)	---
Pc	Dynamic equivalent radial load	N (kgf)	See Formula 032-2.
fw	Load coefficient	--	See Table 032-3.
θ	Oscillating angle /2	Degree	See Fig. 033-1.

How to calculate the static safety coefficient

Basic static rated load is an allowable limit for static load, but its limit is determined by usage. In this case, static safety coefficient of the cross roller bearing can be calculated by Formula 034-2.

Formula 034-1

$$f_s = \frac{C_o}{P_o}$$

Formula 034-2

$$P_o = F_{rmax} + \frac{2M_{max}}{d_p} + 0.44F_{amax}$$

Symbols for Formula 034-1

Table 034-1

C_o	Basic static rated load	N(kgf)	See "Specification of the output bearing" of each series.
P_o	Static equivalent radial load	N(kgf)	See Formula 034-2.

Symbols for Formula 034-2

Table 034-2

F_{rmax}	Max. radial load	N(kgf)	See "How to calculate the maximum moment load" on Page 030.
F_{amax}	Max. axial load	N(kgf)	
M_{max}	Max. moment load	Nm(kgfm)	
d_p	Pitch circle diameter of a roller	m	See Fig. 030-1 and "Specification of the output bearing" of each series.

Static Safety Coefficient

Table 034-3

Operating condition of the roller bearing	f_s
When high rotation precision is required	≥ 3
When shock and vibration are expected	≥ 2
Under normal operating condition	≥ 1.5

HarmonicDrive® Reducer for Precision Control

For Safe Use of Harmonic Drive® Component Set and Gear Unit



Warning : Means that improper use or handling could result in a risk of death or serious injury.



Caution : Means that improper use or handling could result in personal injury or damage to property.

Limited Applications





This product cannot be used for the following applications:

- * Space equipment * Aircraft equipment * Nuclear power equipment * Equipment and apparatus used in domestic homes
- * Vacuum equipment * Automotive equipment * Game equipment * Equipment that directly works on human bodies
- * Equipment for transport of humans * Equipment for use in a special environment





Please consult Harmonic Drive beforehand when intending to use one of its product for the aforementioned applications.

Install a safety device that avoids an accident even if output of this product becomes uncontrollable due to breakdown when using it in equipment that affects human lives and that may trigger serious damage.





Design Precaution: Be certain to read the catalog when designing your equipment.

 Caution	<p>Use only in a specified environment.</p> <ul style="list-style-type: none"> <input type="checkbox"/> Please ensure the following environmental conditions are complied with: <ul style="list-style-type: none"> • Ambient temperature 0 to 40°C • No splashing of water or oil • Do not expose to corrosive or explosive gas • No dust such as metal powder 	 Caution	<p>Install the equipment in a specified manner.</p> <ul style="list-style-type: none"> <input type="checkbox"/> Carry out assembly precisely in the specified order according to the catalog. <input type="checkbox"/> Observe our recommended tightening methods (such as bolts used). <input type="checkbox"/> Operating the equipment without precise assembly can cause troubles such as generation of vibration, reduction of life, deterioration of precision and breakdown.
 Caution	<p>Install the equipment in a specified precision.</p> <ul style="list-style-type: none"> <input type="checkbox"/> Design and assemble parts to maintain the recommended installation and assembly tolerances in the catalog. <input type="checkbox"/> Failure to keep the precision can cause troubles such as vibration, reduction of life, deterioration of precision and breakdown. 	 Caution	<p>Use the specified lubricant.</p> <ul style="list-style-type: none"> <input type="checkbox"/> Using other lubricant than our recommended products can reduce the life. Replace the lubricant in a specified condition. <input type="checkbox"/> Grease is sealed in a unit product. Do not mix other kinds of grease.

Operational Precaution: Be certain to read the catalog before operating the equipment.

 Caution	<p>Be careful in handling products and parts.</p> <ul style="list-style-type: none"> <input type="checkbox"/> Do not impact the parts and units with a hammer, etc. Do not scratch or dent them. Possible damage is assumed. <input type="checkbox"/> If you use the equipment in a damaged condition, the specified performance may not be retained. It can also cause troubles such as breakdown. 	 Caution	<p>Apply torque within the allowable range.</p> <ul style="list-style-type: none"> <input type="checkbox"/> Do not apply torque exceeding the instantaneous allowable max. torque. Applying excess torque can cause troubles such as loose tightening bolts, generation of backlash and breakdown. <input type="checkbox"/> Striking an arm directly attached to the output shaft can damage the arm and make the output shaft uncontrollable.
 Caution	<p>Do not change a set of parts.</p> <ul style="list-style-type: none"> <input type="checkbox"/> The product is manufactured with matched serial numbers. The specified performance may not be retained if you have used mixed sets of parts. 	 Caution	<p>Do not break down unit products.</p> <ul style="list-style-type: none"> <input type="checkbox"/> Do not break down and reassemble unit products. Original performance may not be reproduced.
 Caution	<ul style="list-style-type: none"> <input type="checkbox"/> Rust-proofing was applied before shipping. However, please note that rusting occurs earlier depending on the customers' storage environment. <input type="checkbox"/> Although black oxide finish is applied to some of our products, it does not guarantee the antirust effect. 		

Handling lubricant

 Warning	<p>Precautions on handling lubricant</p> <ul style="list-style-type: none"> <input type="checkbox"/> Use protective eyewear when handling. Avoid contact with eyes. May cause inflammation. <input type="checkbox"/> Use gloves and other skin protection when handling. Avoid contact with skin. May cause inflammation. <input type="checkbox"/> Do not swallow. May cause diarrhea and vomiting. <input type="checkbox"/> Keep out of reach of children. 		<p>Treatment of waste oil and containers</p> <ul style="list-style-type: none"> <input type="checkbox"/> Proper disposal is essential. Dispose of waste oil and waste containers properly in accordance with applicable laws and regulations. <input type="checkbox"/> Do not apply pressure on an empty container. <input type="checkbox"/> Do not weld, heat, drill or cut the container. The remainder may ignite with an explosion.
 Warning	<p>First-aid</p> <ul style="list-style-type: none"> <input type="checkbox"/> EYES: Flush with clean water for at least 15 minutes. Consult a physician. <input type="checkbox"/> SKIN: Thoroughly remove with cloth or paper and wash with soap and water. <input type="checkbox"/> INGESTION: Consult a physician immediately. Do not induce vomiting. <input type="checkbox"/> INHALATION: Immediately seek fresh air if adverse effects are observed. 	 Caution	<p>Storage</p> <ul style="list-style-type: none"> <input type="checkbox"/> Close the container tightly after use in order to prevent contamination with dust or moisture. Avoid direct exposure to sunlight. Store at room temperature.
			<p>When Discarding Actuator and Servo Driver</p>  Caution
			<p>Please discard as industrial waste.</p> <ul style="list-style-type: none"> <input type="checkbox"/> Please discard as industrial waste when discarding.

Harmonic Drive LLC

Boston US Headquarters

247 Lynnfield Street
Peabody, MA 01960

New York Sales Office

100 Motor Parkway
Suite 116
Hauppauge, NY 11788

California Sales Office

333 W. San Carlos Street
Suite 1070
San Jose, CA 95110

Chicago Sales Office

137 N. Oak Park Ave., Suite 410
Oak Park, IL 60301

T: 800.921.3332

T: 978.532.1800

F: 978.532.9406

www.HarmonicDrive.net

Group Companies

Harmonic Drive Systems, Inc.
6-25-3 Minami-Ohi, Shinagawa-ku
Tokyo 141-0013, Japan

Harmonic Drive AG
Hoenbergstrasse, 14, D-6555
Limburg/Lahn Germany

Harmonic Drive®, Harmonic Gearhead®, Harmonic Planetary® and Quick Connect® are registered trademarks of Harmonic Drive LLC. All other trademarks are property of their respective owners.

