

Quick Connect Gearheads

Quick Connect Gearheads
CSF-GH Series

HIGH PERFORMANCE
EASY TO USE



Total Motion Control

Harmonic Drive™ gear

Precision Gearing and Motion Control

HARMONIC DRIVE™ PRECISION GEAR

CSF SERIES : QUICK CONNECT GEARHEADS

The CSF-GH series gearhead has been designed to easily mount to any motor, yet maintain all of the benefits of Harmonic Drive™ precision gearing including high accuracy and zero-backlash. The gearhead has a compact and lightweight construction.

This gearhead features high performance precision gearing which uses Harmonic Drive LLC's patented technologies and manufacturing expertise.



- **ZERO BACKLASH** The unique operating principles of Harmonic Drive™ strain wave precision gearing enable the gear teeth to be continually preloaded which provides zero backlash in the tooth mesh.
- **HIGH MOMENT CAPACITY** A high stiffness cross roller bearing is used as the output bearing. This bearing can support high radial, axial, and moment loads.
- **Easy to Use** An adapter flange and clamp-style shaft coupling allows easy assembly with a servo motor.
- **WIDE RANGE OF SIZES AND GEAR RATIOS**
 Sizes: 14, 20, 32, 45, 65
 Ratios: 50:1, 80:1, 100:1, 120:1, 160:1
- **AVAILABLE OUTPUT CONFIGURATIONS** Shaft or Flange
- **COMPATIBLE MOTOR SIZES** 30w ~ 5000w

Rating Table

Size	Gear Ratio	Rated Torque @2000rpm		Repeated Peak Torque		Limited For Average Torque		Emergency Torque		Limit for Average Input Speed rpm	Max Speed rpm	Weight*		Inertia*	
		Nm	lb-in	Nm	lb-in	Nm	lb-in	Nm	lb-in			kg	lb	kgcm ²	lb-in ²
14	50	5.4	48	18	159	6.9	61	35	310	3500	8500	0.9	1.9	0.041	0.014
	80	7.8	69	23	204	11	97	47	416						
	100	7.8	69	28	248	11	97	54	478						
20	50	25	221	56	496	34	301	98	867	3500	6500	2.5	5.5	0.24	0.083
	80	34	301	74	655	47	416	127	1124						
	100	40	354	82	726	49	434	147	1301						
	120	40	354	87	770	49	434	147	1301						
	160	40	354	92	814	49	434	147	1301						
32	50	76	673	216	1912	108	956	382	3381	3500	4800	6.8	15	2.1	0.72
	80	118	1044	304	2691	167	1478	568	5027						
	100	137	1212	333	2948	216	1912	647	5726						
	120	137	1213	353	3124	216	1912	686	6072						
	160	137	1213	372	3292	216	1912	686	6072						
45	50	176	1558	500	4425	265	2345	950	8408	3000	3800	17	37	11	3.7
	80	313	2770	706	6249	390	3452	1270	11240						
	100	353	3124	755	6682	500	4425	1570	13895						
	120	402	3558	823	7284	620	5487	1760	15577						
	160	402	3558	882	7806	630	5576	1910	16904						
65	80	745	6594	2110	18675	1040	9205	3720	32925	1900	1900	29	65	59	20
	100	951	8417	2300	20357	1520	13453	4750	42041						
	120	951	8417	2510	22215	1570	13896	4750	42041						
	160	951	8417	2630	23277	1570	13896	4750	42041						

* Values are approximate and are determined by adapter, shaft coupling, and output flange/shaft configurations.

Motor Power vs. Gearhead Size & Gear Ratio

Motor Power (w)	Gear Ratio				
	1/50	1/80	1/100	1/120	1/160
30			# 14		
50			# 14		
100			# 14		
200			# 20		
400			# 20		
600			# 32		
750			# 32		
1000			# 32		
1500			# 45		
2000			# 45		
2500			# 45		
3000			# 45		
3500			# 65		
4000			# 65		
4500			# 65		
5000			# 65		



SHAFT OUTPUT



FLANGE OUTPUT

Dimensions

unit: mm

Size	14	20	32	45	65
ΦA	-	-	-	-	-
B	-	-	-	-	-
C	8	10	13	16	25
D	21	27	35	53	57
ΦE	56 h7	85 h7	115 h7	165 h8	220 h8
ΦF	40	59	84	122	168
G	60	90	120	170	230
weight (g)	-	-	-	-	-

Positional Accuracy

Size	14	20	32	45	65
arc-min	1.5	1	1	1	1

* Dimensions ΦA and B depend on the chosen Motor/Adapter Flange combination.

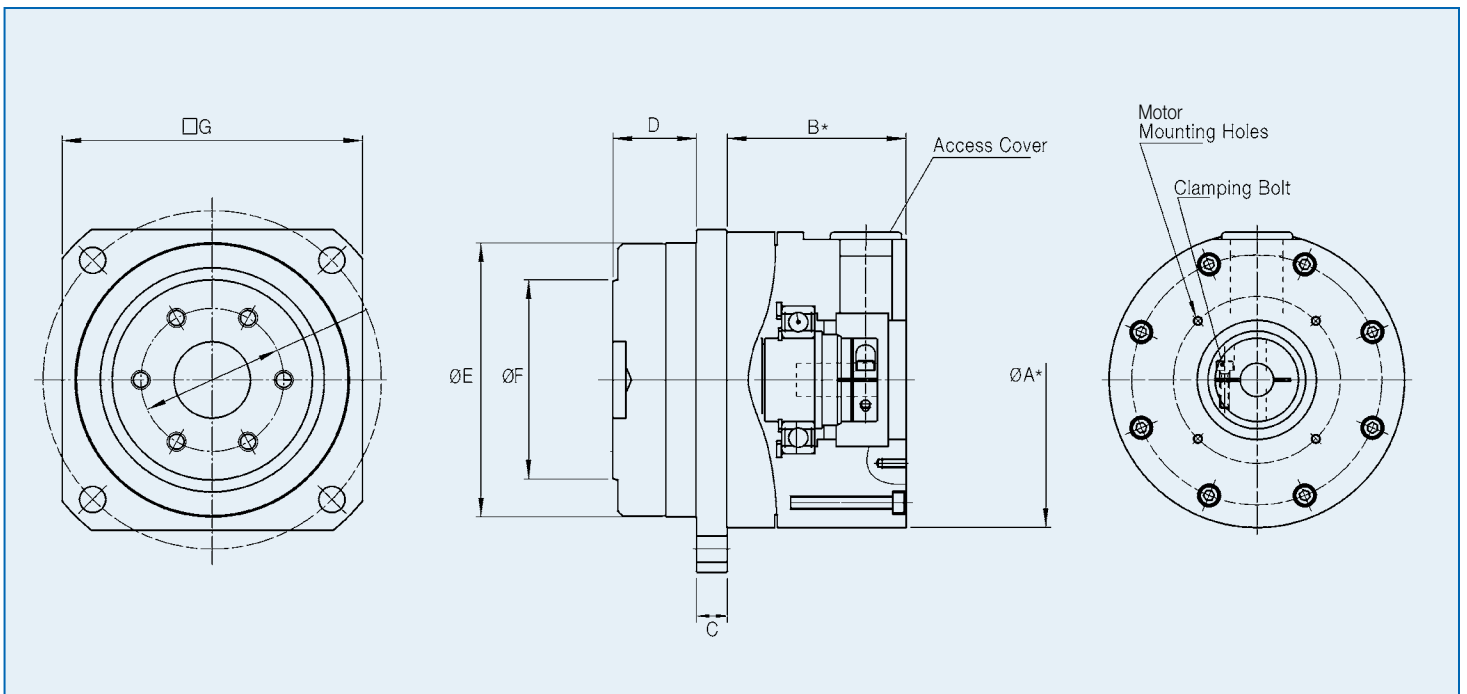

Starting Torque

[N-cm]

Size	14		20		32		45	65
Ratio	Standard Adapter	Using Small Motor Adapter	Using Large Motor Adapter	Using Small Motor Adapter	Using Large Motor Adapter	Standard Adapter	Standard Adapter	
50	8.2	13	20	50	58	123	-	
80	6.9	10	17	38	46	95	186	
100	6.6	9.6	16	37	45	89	166	
120	-	9.1	16	34	42	85	156	
160	-	8.6	15	33	41	79	139	

Output Bearing Specifications

Size	Pitch circle dp	Offset R	Basic Load	
			Dynamic Load Rating C	Static Load Rating Co
	m	m	N	N
14	0.0405	0.011	5110	7060
20	0.064	0.0115	10600	17300
32	0.085	0.014	20500	32800
45	0.123	0.019	41600	76000
65	0.170	0.0225	81600	149000

Size	Permissible dynamic tilting moment	Moment Stiffness	Permissible Axial Load	Permissible Radial Load
	Nm	*10 ⁴ Nm/rad	N	N
14	27	3.0	1093	732
20	145	17	2267	1519
32	258	42	4385	2938
45	797	100	8899	5962
65	1992	412	17454	11693

[in-lb] = [Nm] x 8.85

[lb] = [N] x 0.225

ORDERING INFORMATION

Quick Connect Gearheads	Size	Gear Ratio	Quick Connect Configuration	Output	Motor
CSF Series	14	50 80 100	GH	F0: Flange Output J2: Shaft Output, No Keyway or Tapped Hole J6: Shaft Output, Key and Tapped Hole	Please provide the model number of the motor being coupled to this gearhead so we can specify a unique Harmonic Drive LLC P/N for a ready-to-mount gearhead.
	20	50 80 100 120 160			
	32				
	45				
	65	80 100 120 160			

CSF - 20 - 160 - GH - F0 - XXX

Harmonic Drive LLC

Boston US Headquarters
247 Lynnfield Street
Peabody, MA 01960

New York Sales Office:
Harmonic Drive LLC
100 Motor Parkway
Suite #116
Hauppauge, NY 11788

San Jose Sales Office:
Harmonic Drive LLC
2033 Gateway Place
Suite #639
San Jose, CA 95110

T: 800-921-3332

F: 978-532-9406

www.HarmonicDrive.net



Worldwide Locations:

Harmonic Drive Systems, Inc.
Minamiohi 6-25-3, Shinagawa-ku
Tokyo 140, Japan

Harmonic Drive AG
Hoenbergstr, 14
Limburg/Lahn, D-65555 Germany

Harmonic Drive is a trademark of Harmonic Drive LLC.

Rev 08-11

All products are warranted to be free from design or manufacturing defects for a period of one year from the date of shipment. Such items will be repaired or replaced at the discretion of Harmonic Drive LLC. The seller makes no warranty, expressed or implied, concerning the material to be furnished other than it shall be of the quality and specifications stated. The seller's liability for any breach is limited to the purchase price of the product. All efforts have been made to assure that the information in this catalog is complete and accurate. However, Harmonic Drive LLC is not liable for any errors, omissions or inaccuracies in the reported data. Harmonic Drive LLC reserves the right to change the product specifications, for any reason, without prior notice.