

FR Gearing



harmonic drive gearing
Precision Gearing & Motion Control

Contents

The Basic Assembly	2
Configurations	3
Ordering Information	3
Typical Applications	4
Dimensions	5
Rating Table	6
Moment of Inertia	9
Torsional Characteristics and Backlash	10
Lubrication	11
Installed Relationship and Recommended Tolerances for Housing	12
Efficiency	13
No-Load Starting Torque and Backdriving Torque	15

The Basic Assembly

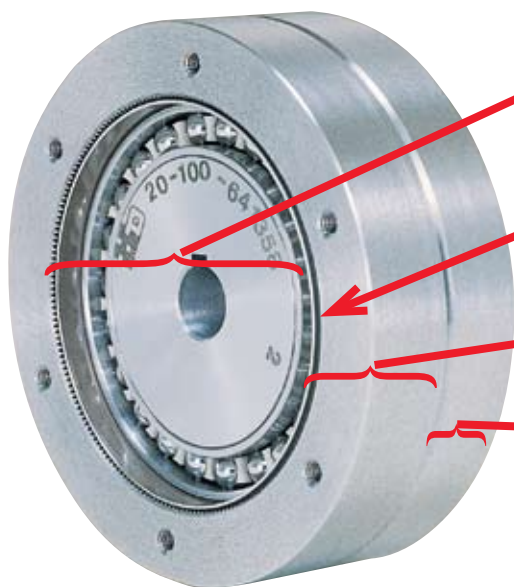

- 1) The Wave generator (WG) is a thin raced bearings assembly fitted onto an elliptical plug, and normally is the rotating input member.
- 2) The Flexspline (FS) is a non-rigid ring with external teeth on a slightly smaller pitch diameter than the Circular Spline. It is fitted over and is elastically deflected by the Wave Generator.
- 3) The Circular Spline (CS) is a rigid ring with internal teeth, engaging the teeth of the Flexspline across the major axis of the Wave Generator.
- 4) The Dynamic Spline (DS) is a rigid ring having internal teeth of same number as the Flexspline. It rotates together with the Flexspline and serves as the output member. It is identified by chamfered corners at its outside diameter.

The FR range has been developed to meet the trend towards flatter gear sets while retaining the many advantages of harmonic drive gearing. It consists of four main parts: Wave Generator, Flexspline, Dynamic Spline, and Circular Spline. When assembled, rotation of the Wave Generator as a high speed input member imparts a rotating elliptical shape to the Flexspline. This causes progressive engagement of its external teeth with the internal teeth of the Circular Spline. The

fixed Circular Spline, having a larger number of teeth than the Flexspline causes the latter to precess at a rate determined by the ratio of tooth difference to the total number of teeth.

With the same number of teeth as the Flexspline, The Dynamic Spline rotates with, and at the same speed as, the Flexspline and is the output member of the drive.

Configurations

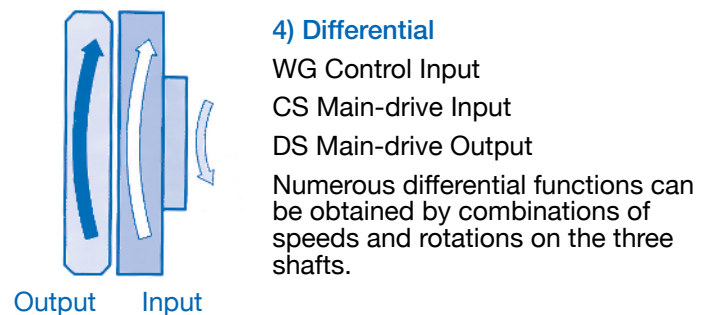
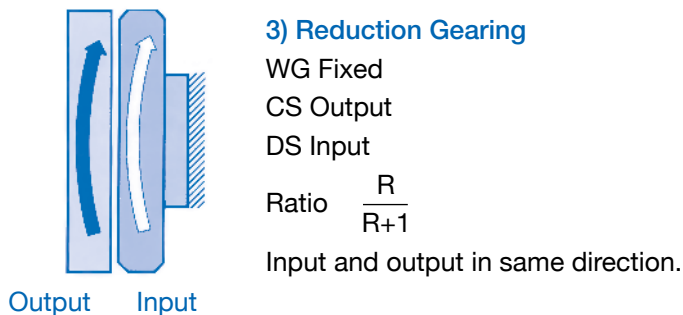
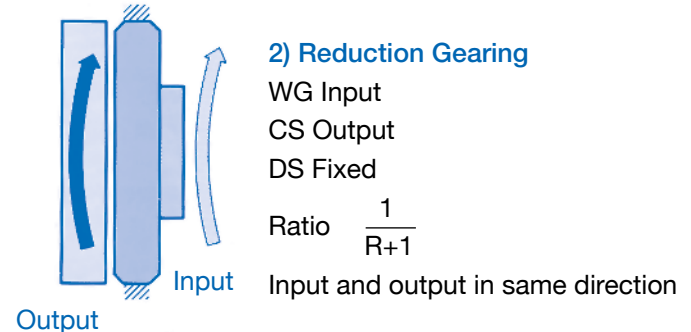
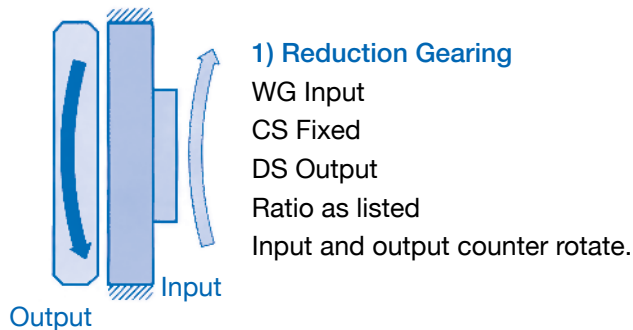

Ordering Information

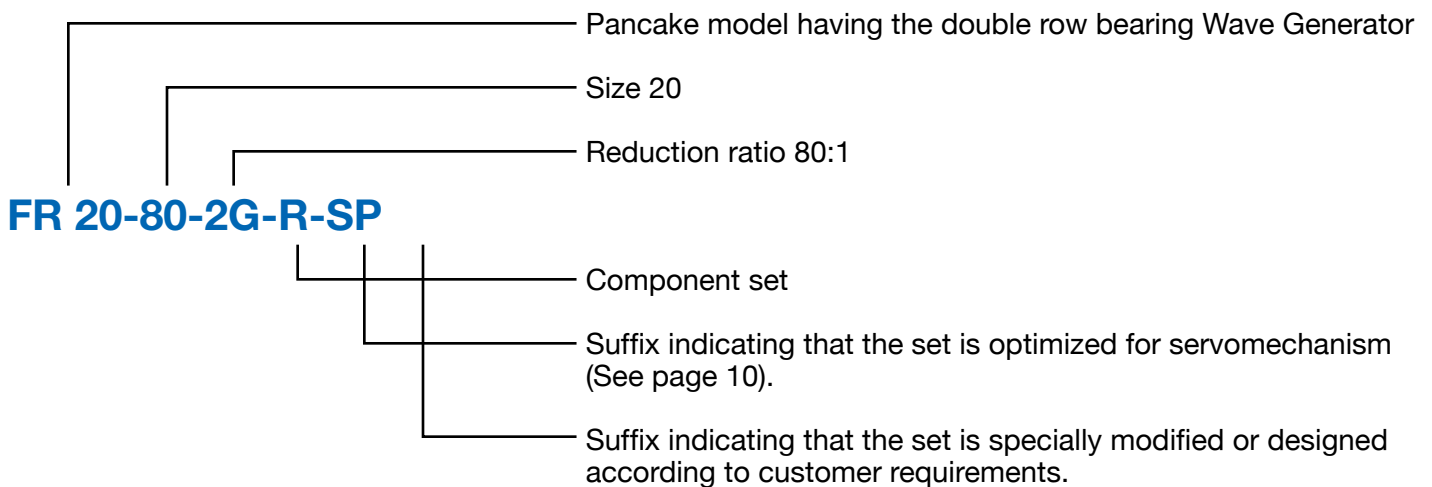

Typical Applications

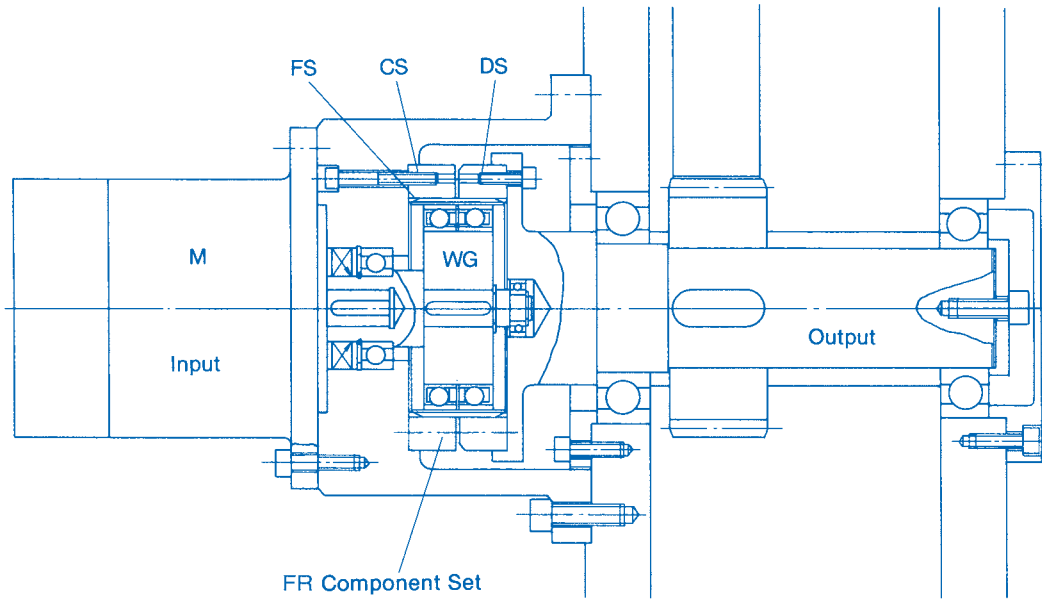

Shown above is an FR component set used as a milling machine

Advantages:

- Maximum reduction ratio in minimum space
- Low backlash
- Simple installation and maintenance

This application makes the most of the harmonic drive gearing's unique features. The motor drives the Wave Generator (WG), and the Circular Spline (CS) is fixed to the casing. The output is taken from the Flexspline (FS) via the Dynamic Spline (DS). If the motor shaft is not oil sealed, an additional oil seal must be fitted.

The installation tolerances may be found on page 12.

The FR component set shown is the drive of a robot joint. The input shaft is hollow, allowing another input shaft for the next stage to go through the Wave Generator. In another robotics application the hollow shaft is used to accommodate electric cables.

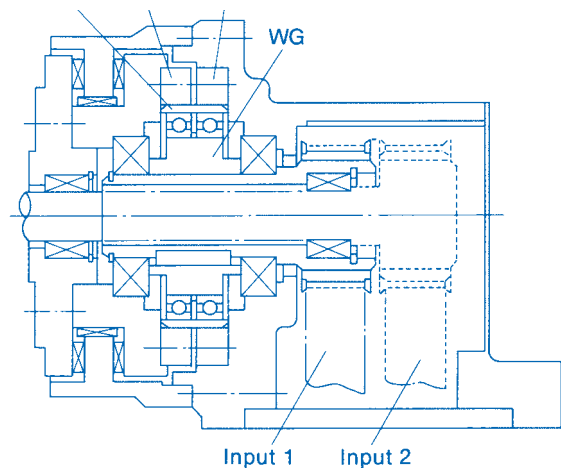

Dimensions

FR 20-100 (See inset FR 14 Wave Generator)

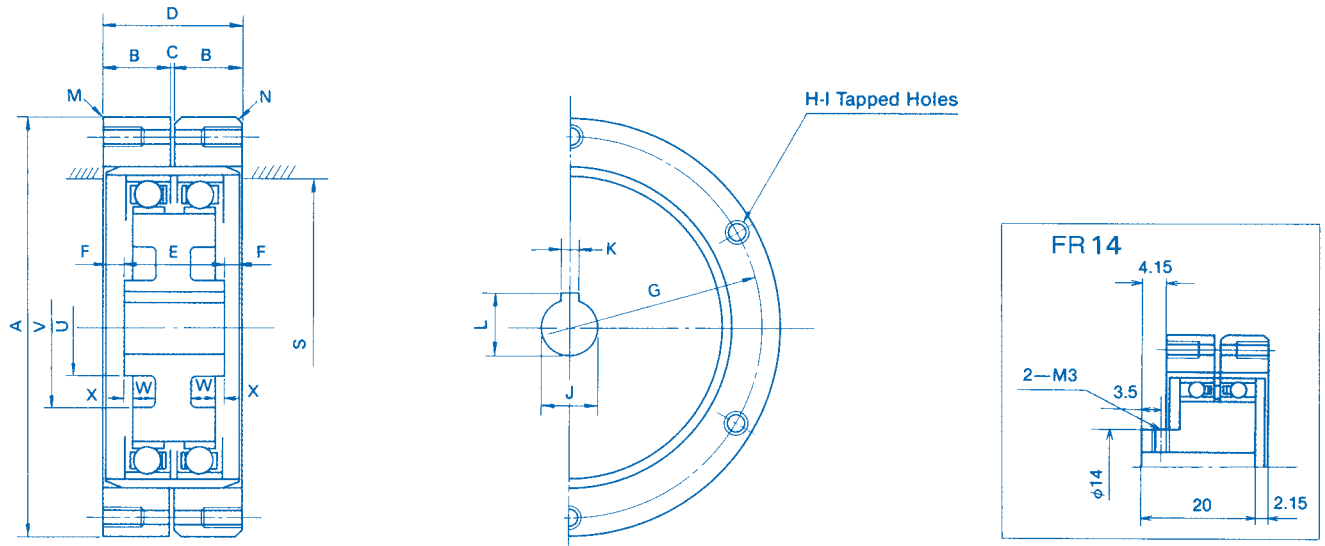

FR	14	20	25	32	40	50	65	80	100	
A (h6)	50 ⁰ _{-0.016}	70 ⁰ _{-0.019}	85 ⁰ _{-0.022}	110 ⁰ _{-0.022}	135 ⁰ _{-0.025}	170 ⁰ _{-0.025}	215 ⁰ _{-0.029}	265 ⁰ _{-0.032}	330 ⁰ _{-0.036}	
B	8.5	12	14	18	21	26	35	41	50	
C	1	1	1	1	1	1	1	1	1	
D	18	25	29	37	43	53	71	83	101	
E	—	17.3	20	25.9	31.5	39.1	50.5	62	77.2	
F	—	3.85	4.5	5.55	5.75	6.95	10.25	10.5	11.9	
G	44	60	75	100	120	150	195	240	290	
H	6	6	6	6	6	6	6	8	8	
I	M3 x 6	M3 x 6	M4 x 8	M5 x 10	M6 x 12	M8 x 16	M10 x 20	M10 x 20	M12 x 24	
J (H7) max.	6 ^{+0.012} ₀	9 ^{+0.015} ₀	11 ^{+0.018} ₀	14 ^{+0.018} ₀	14 ^{+0.018} ₀	19 ^{+0.021} ₀	24 ^{+0.021} ₀	28 ^{+0.021} ₀	28 ^{+0.021} ₀	
K (JS9)	—	3 ^{+0.0125}	4 ^{+0.0150}	5 ^{+0.0150}	5 ^{+0.0150}	6 ^{+0.0150}	8 ^{+0.0180}	8 ^{+0.0180}	8 ^{+0.0180}	
L	—	10.4	12.8	16.3	16.3	21.8	27.3	31.3	31.3	
M (C)	0,2	0.2	0.2	0.2	0.4	0.4	0.4	0.4	0.4	
N (C)	1	1	1.5	1.5	1.5	1.5	1.5	2	2	
U	—	—	22	28	32	38	44	52	58	
V	—	—	32	42	52	62	86	100	128	
W	—	—	4.8	6.1	7.6	9.8	12.6	16	19.7	
X	—	42	1.6	1.9	2.5	3.2	4.4	5.1	6.3	
S	29	42	53	69	84	105	138	169	211	
Wt	lb	0.4	1.1	1.8	3.7	6.8	13.2	27.3	48.9	93.5
	kgf	0.2	0.5	0.8	1.7	3.1	6.0	12.4	22.2	42.5

*The axial location surfaces at D width must extend radially inward to at least to S for Flexspline containment. The surface hardness in the region where the Flexspline abuts is recommended to be RC29-34.

Rating Table

FR	Gear Ratio	Rated Speed	Rated Torque at 2000rpm		Repeated Peak Torque		Max. Average Load Torque		Max. Momentary Torque		Max. Input Speed, rpm		Limit for average Input Speed, rpm	
		rpm	N.m	In.lb	N.m	In.lb	N.m	In.lb	N.m	In.lb	Oil Lub.	Grease Lub.**	Oil Lub.	Grease Lub.**
14	50	2,000	4.4	39	5.4	48	5.4	48	13.7	121	6,000	3,600	4,000	2,500
	88		5.9	52	9.8	87	9.8	87	19.6	173*				
	100		7.8	69	13.7	121	9.8	87	19.6	173*				
	110		7.8	69	13.7	121	9.8	87	19.6	173*				
20	50	2,000	25	221	34	301	34	301	69	611	6,000	3,600	3,600	2,500
	80		34	301	41	363	41	363	72	637				
	100		40	354	53	469	49	434	94	832				
	128		40	354	67	593	49	434	102	903*				
	160		40	354	77	681	49	434	86	761*				
25	50	2,000	39	345	55	487	55	487	108	956	5,000	3,600	3,000	2,500
	80		56	496	69	611	69	611	122	1,080				
	100		67	593	91	805	91	805	160	1,416				
	120		67	593	108	956	108	956	190	1,682				
	160		67	593	135	1,195	108	956	172	1,522*				
	200		67	593	147	1,301	108	956	172	1,522*				
32	50	2,000	76	673	108	956	108	956	216	1,912	4,500	3,600	2,500	2,300
	78		108	956	137	1,212	137	1,212	245	2,168				
	100		137	1,212	176	1,558	176	1,558	323	2,859				
	131		137	1,212	255	2,257	216	1,912	451	3,991				
	157		137	1,212	294	2,602	216	1,912	500	4,425*				
	200		137	1,212	314	2,779	216	1,912	372	3,292*				
	260		137	1,212	314	2,779	216	1,912	372	3,292*				
40	50	2,000	137	1,212	196	1,735	196	1,735	353	3,124	4,000	3,300	2,000	2,000
	80		196	1,735	245	2,168	245	2,168	431	3,814				
	100		255	2,257	314	2,779	314	2,779	549	4,859				
	128		294	2,602	392	3,469	392	3,469	686	6,071				
	160		294	2,602	461	4,080	451	3,991	813	7,195				
	200		294	2,602	529	4,682	451	3,991	745	6,593*				
	258		294	2,602	627	5,549	451	3,991	745	6,593*				
50	80	1,700	363	3,213	440	3,894	441	3,903	784	6,938	3,500	3,000	1,700	1,700
	100		470	4,160	578	5,115	578	5,115	1,019	9,018				
	120		559	4,947	696	6,160	696	6,160	1,225	10,841				
	160		559	4,947	833	7,372	833	7,372	1,470	13,010				
	200		559	4,947	960	8,496	843	7,461	1,411	12,487*				
	242		559	4,947	1176	10,408	843	7,461	1,411	12,487*				
65	78	1,400	745	6,593	921	8,151	921	8,151	1,617	14,311	3,000	2,200	1,400	1,400
	104		1,070	9,470	1,340	11,859	1,340	11,859	2,360	20,886				
	132		1,070	9,470	1,650	14,603	1,570	13,895	2,890	25,577				
	158		1,070	9,470	1,970	17,435	1,570	13,895	3,450	30,533*				
	208		1,070	9,470	2,180	19,293	1,570	13,895	2,590	22,922*				
	260		1,070	9,470	2,200	19,470	1,570	13,895	2,590	22,922*				
80	80	1,200	1,320	11,682	1,640	14,514	1,640	14,514	2,870	25,400	2,500	2,000	1,200	1,200
	96		1,660	14,691	2,050	18,143	2,050	18,143	3,580	31,772				
	128		2,300	20,355	2,820	24,957	2,830	25,046	4,960	43,896				
	160		2,360	20,798	3,380	29,913	3,130	27,701	5,940	52,569				
	194		2,350	20,798	4,300	38,055	3,130	27,701	6,900	61,065*				
	258		2,350	20,798	4,350	38,498	3,130	27,701	5,170	45,755				
	320		2,350	20,798	4,350	38,498	3,130	27,701	5,170	45,755*				
100	80	1,000	2,350	20,621	2,870	25,400	2,870	25,400	5,040	44,604	2,000	1,700	1,000	1,000
	100		2,330	28,320	3,940	34,869	3,940	34,869	6,920	61,242				
	120		3,200	34,427	4,780	42,303	4,780	42,303	8,400	74,340				
	160		4,470	39,560	6,230	55,136	5,720	50,622	10,950	96,908				
	200		4,470	39,560	7,090	62,747	5,720	50,622	12,440	110,094				
	242		4,470	39,560	7,960	70,446	5,720	50,622	9,410	83,279*				
	320		4,470	39,560	7,960	70,446	5,720	50,622	9,410	83,279*				

*Torque value limited by "Ratcheting", see page 8. **For operating conditions see grease lubrication, page 11.

How To Use The Rating Table

Because of their simple, convenient construction and positional and rotational accuracy, harmonic drive component sets are used in large numbers in servo-controlled drives where the load and driving speed are seldom constant. With such applications in mind, the rating table presents four important torque capacity limits:

- Rated Torque at rated speed
- Allowable limit for Average Torque
- Allowable limit for repeated Peak Torque
- Allowable limit for Momentary Peak Torque

Rated Torque at Rated Input Speed

This is the maximum allowable output torque that can be developed continuously at the rated input speed shown in the first column. When a harmonic drive component set is to be operated at speeds other than the rated torque, the actual torque load at each speed needs to be converted to an Equivalent Torque (T_{eq}) using formulas 1, 2, and 3 on page 9.

Allowable Limit for Average torque

When a harmonic drive unit is used under a variable load, Average Torque may be calculated by formula 1 on page 9. Thus calculated Average Torque

should not exceed this limit. Ignoring this limit will result in excessive heat generation, tooth wear, and deterioration of lubricant.

Allowable Limit for Repeated Peak Torque

This is the allowable output torque that can be developed when starting and stopping operation. Peak torque developed at starting and stopping can be estimated if the moment of inertia of motor and load, and accelerating (or decelerating) time are known.

Allowable Limit for Momentary Peak torque

Aside from the peak torque developed at starts and stops, harmonic drive transmission may be subjected to yet another type of peak torque, an example of which is the shock load generated by an emergency stop of the servo system. Another example is the shock load generated when the driven element, such as a robot hand, accidentally hits a hard object. The Rating Table gives the limit for such Momentary Peak Torque. **Momentary Peak Torque must be restricted not only in its value but also in its frequency of occurrence.** This is further explained in the next chapter titled “Factors Affecting Torque Capabilities.”

The variation of load and speed in typical operating cycles are schematically illustrated in the diagrams below.

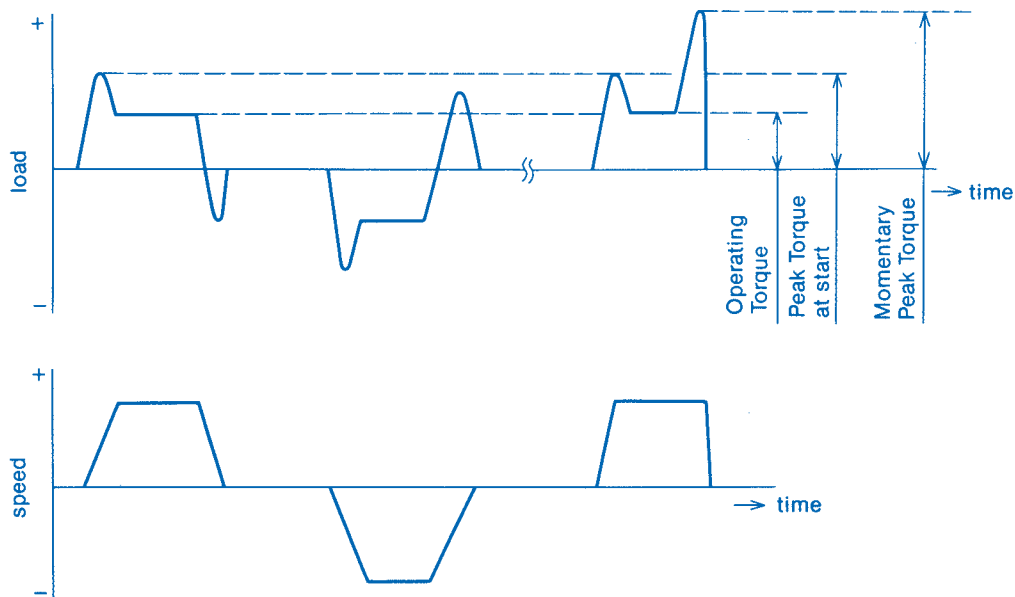

Factors Affecting Torque Capabilities

The torque capabilities quoted in the Rating Table are determined by considering three factors: the strength of the Flexspline, the unit's ability to resist a phenomenon called ratcheting, and the operating life of the Wave Generator bearing.

Flexspline Strength

The Flexspline, the non-rigid member, is subjected to repeated deflections, and its strength limits the rating of the entire harmonic drive unit. The values given for Rated Torque at Rated Speed, Limits for Average Torque, and repeated Peak Torque are for the infinite fatigue life of the Flexspline. The Limit For Momentary Peak torque, however, exceeds the infinite fatigue limit of the Flexspline, and the load at this level must be restricted to 1×10^4 flex-cycles. **Operating conditions exceeding the limit will lead to failure of the Flexspline.**

The allowable frequency of occurrence (N) of Momentary Peak Torque may be calculated by:

$$N \leq \frac{1 \times 10^4}{2 \times \frac{n}{60} \times t}$$

where n is the input speed in rpm and t is the duration of Momentary Peak Torque in seconds. Note that there are two flex-cycles for each input revolution. For example, if Momentary peak torque is expected to occur at a 2,000 rpm input speed and to last for 0.15 seconds, then:

$$N \leq \frac{1 \times 10^4}{2 \times \frac{2,000}{60} \times 0.15} \leq 1,000$$

Ratcheting

Another torque limit for harmonic drive transmissions under dynamic load is set by a momentary load releasing phenomenon called ratcheting. This is slippage of the meshing of the Circular Spline and Flexspline teeth as the result of deformation of drive members under excessive load.

In the Rating Table, values marked with asterisk(*) are the torque limits related to ratcheting. Ratcheting usually does not lead to immediate drive failure, but may result in "dedoidal", an improper tooth mesh that may cause undesirable vibration or eventual failure of the Flexspline. The ratchet point will decrease with each subsequent incident, and should not be intentionally utilized for machine overload protection purposes.

Operator Life of the Wave Generator Bearing

The life expectancies of harmonic drive component sets are based on the median life of the Wave Generator bearing. Rated Torque at Rated Speeds are based on a median bearing life (L_{50}) of approximately 15,000 hours. This means that operated at the constant rated speed and rated torque, 50 percent of a group of bearings would fail before these service hours.

Life expectancy of a unit operated at speed n and torque T conditions may be estimated by the relationship given below:

$$L_{50} = 15,000 \cdot \frac{\text{Rated Speed}}{n} \cdot \left(\frac{\text{Rated torque at rated Speed}}{T} \right)^3$$

Operating Speed

The Rating Table gives two limits, Maximum Input Speed and Limit for Average Input Speed, for both oil-lubricated and grease-lubricated units. Units may be operated continuously up to the maximum input speed limits, provided that the average speed during the operation, as calculated by formula 2, on pages 11 and 12, does not exceed the limit for the average input speed.

For continuous operation of grease-lubricated units at these speed limits, it is recommended that grease specially developed for harmonic drive transmissions be used. For a list of recommended available lubricants, see page 10 and 11.

How To Select A Unit From The Rating Table

In actual applications, operating conditions are seldom constant. Torque and speed vary, and peak torque develops during acceleration and deceleration. The first step is to convert these variable torques and speeds to a constant average torque and speed.

Step 1: Average Torque and Speed

Consider a hypothetical operating cycle such as shown in the diagram on the following page

T_1 is the Peak torque developed during the acceleration t_1 , T_2 is the Operational torque at constant speed n_2 that lasts for a period of t_2 , and T_3 is the Peak Torque developed during acceleration t_3 . n_1 and n_3 represent the Average Speed during acceleration and deceleration, which in this case are $\frac{n_2}{2}$

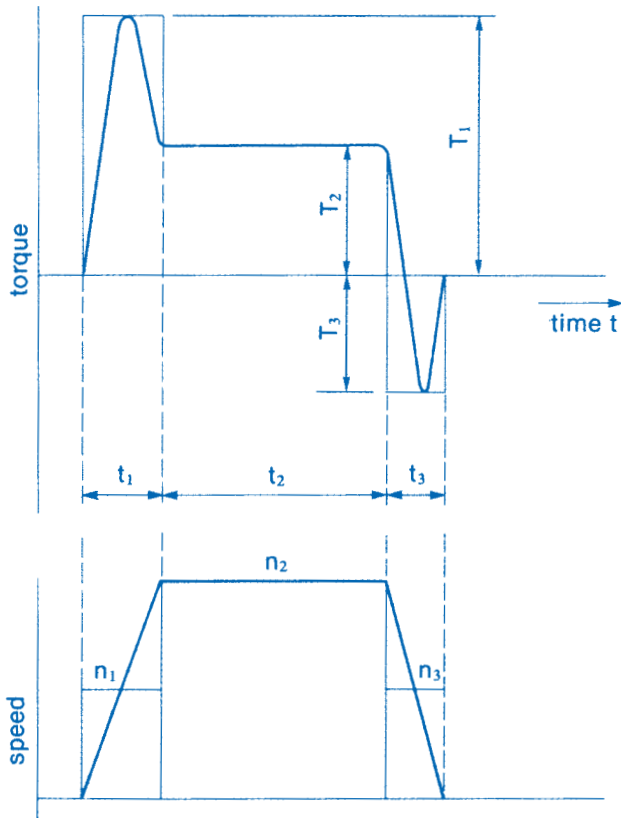

Example

A drive unit FR 40 ratio 100:1 is being considered for these operating torques and speeds:

Torque

- Peak torque during acceleration T_12500 lb-in
- Operating torque T_21740 lb-in
- Peak torque during deceleration T_32200 lb-in

Time

- Accelerating time t_1 0.2 seconds
- Operating time t_2 2.0 seconds
- Decelerating time t_3 0.3 seconds

Speed

- Operating speed n_2 2200 rpm
- Average speed during acceleration and deceleration n_1 and n_3 1100 rpm

Step 1

$$T_{av} = \sqrt[3]{\frac{1100 \times 0.2 \times 2500^3 + 2200 \times 2 \times 1740^3 + 1100 \times 0.3 \times 2200^3}{1100 \times 0.2 + 2200 \times 2 + 1100 \times 0.3}}$$

$$= 1826 \text{ lb-in}$$

$$n_{av} = \frac{1100 \times 0.2 + 2200 \times 2 + 1100 \times 0.3}{0.2 + 2 + 0.3} = 1980 \text{ rpm}$$

Step 2

$$T_{eq} = 1826 \cdot \sqrt[3]{\frac{1,980}{2,000}} = 1,820 \text{ lb-in}$$

Step 3

It is estimated that approximately 4,500 lb-in of peak torque will develop momentarily at an emergency stop, which is estimated to take place at 2,200 rpm and last for 0.15 seconds. Allowable frequency of such Momentary Peak Torque is:

$$N = \frac{1 \times 10^4}{2 \times \frac{2,200}{60} \times 0.15} = 900 \text{ times}$$

Step 4: Conclusion

Entering the Rating Table at the line corresponding to FR 40-100 we find that T_{eq} , T_{av} , Repeated Peak Torque and Momentary Peak Torque values, and speed conditions of this application are within the allowable limits:

	Estimated Operating Conditions	Rating and Limits
Equivalent Torque T_{eq}	1,820 lb-in	2,220 lb-in
Average Torque, T_{av}	1,826 lb-in	2,780 lb-in
Repeated Peak Torque	2,500 and 2,200 lb-in	2,770 lb-in
Momentary Peak Torque	4,500 lb-in	4,860 lb-in
Average Speed, n_{av}	1,980 rpm	2,000 rpm

Therefore, this unit is considered adequate for this application. It can be lubricated either with oil or Harmonic Grease SK-1. The occurrence of emergency stops must be less than 900 times during the expected service life of this unit.

The Average Torque T_{av} for this cycle is calculated:

$$T_{av} = \sqrt[3]{\frac{n_1 t_1 T_1^3 + n_2 t_2 T_2^3 + n_3 t_3 T_3^3}{n_1 t_1 + n_2 t_2 + n_3 t_3}}$$

The Average Speed n_{av} for this cycle is

$$n_{av} = \frac{n_1 t_1 + n_2 t_2 + n_3 t_3}{t_1 + t_2 + t_3}$$

Step 2

The second step is to calculate as below an Equivalent Torque T_{eq} that would give a median bearing life of 15,000 hours.

$$T_{eq} = T_{av} \cdot \sqrt[3]{\frac{n_{av}}{\text{Rated Speed}}}$$

Step 3

The third step is to estimate the level of Momentary Peak Torque and the frequency of its occurrence. Estimated Momentary Peak Torque must be less than the allowable limit given in the Rating Table, and the frequency of its occurrence must not exceed 1×10^4 flex-cycles.

Step 4

The fourth step is to check these operating conditions against the values and limits given in the Rating Table for a unit under consideration. If any of the operating conditions exceed the limits, either the operating condition must be relaxed or another unit must be selected.

Moment of Inertia

Inertia values at the high-speed shaft for FR component sets are given in table below.

Units with reduced input inertia may be supplied on a custom basis. Since the reduction of inertia

is achieved by modifying the Wave generator and may affect the unit's torque capacity, each application requiring reduced inertia needs to be evaluated individually.

FR		14	20	25	32	40	50	65	80	100
Moment of Inertia J	kg-cm ²	0.06	0.32	0.70	2.6	6.8	21	76	213	635
	lb-in ²	0.02	0.11	0.24	0.89	2.3	7.1	26	73	217

Torsional Characteristics and Backlash

The torsional characteristics of the drive are an important consideration in a servo-drive system. When torque is applied to the output of the harmonic drive unit with the input rotationally locked, the torque-torsion relationship measured at the output typically follows the loop O-A-B-A'-B'-A illustrated.

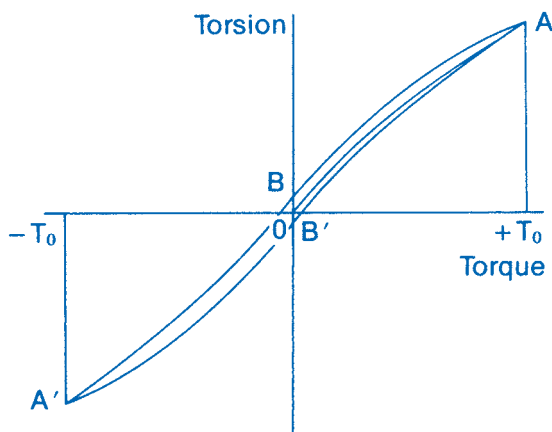

Three major characteristics of interest in a servo driver are:

- 1) Harmonic drive gearing exhibits soft wind-up characteristics in the low torque region. The spring rates for three regions of the torque-torsion curve are given on pages 9 and 10.
- 2) The backlash in an assembled harmonic drive component set is defined as pure play existing between the input and output. Because of double row teeth mesh, FR component set exhibits backlash somewhat larger than CSF component sets. Backlash of Series R (for robotics application) is optimized below 1.5 minutes of arc for all sizes. Backlash of non-optimized units are quoted below. Values are measured at output with input looked.

Backlash in assembled FR

min. of arc

FR	14	20	25	32	40	50	65	80	100
Optimized, less than	1.5	1.5	1.5	1.5	1.5	1.5	1.5	1.5	1.5
Non-optimized, less than	32	32	30	24	24	23	23	23	21

Spring Rate

For servo-drive applications, the torsional stiffness of the FR component set may be evaluated by dividing the torque-torsion curve in three major regions: a small torque region O-T₁, a middle torque region T₁-T₂, and a linear region T₂-T₃. Spring rates of these regions vs. size standard units are tabulated. The values quoted are the average of many tests of actual units. The spring rate of an individual unit may vary within approximately ±30% of the average.

Torque-Torsion Curve

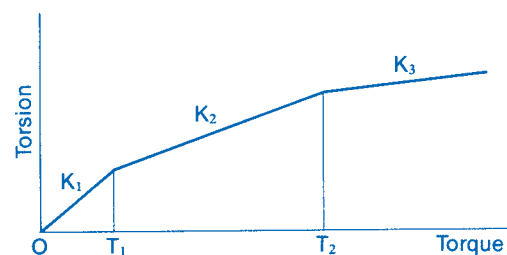

- K₁: Spring rate for torque region O-T₁
- K₂: Spring rate for torque region T₁-T₂
- K₃: Spring rate for torque region over T₂

Spring Rate FR Component Sets Series R

FR	T1		K ₁ x10 ⁹ /rad		T2		K ₂ x10 ⁴ /rad		K ₃ x10 ⁴ /rad	
	Nm	lb-in	Nm	lb-in	Nm	lb-in	Nm	lb-in	Nm	lb-in
14	1.0	8.9	0.26	2.3	5.0	44	0.64	5.7	1.0	8.9
20	2.0	17.4	0.81	7.2	23	200	2.8	25	3.0	27
25	5.0	43	1.6	14	37	330	3.7	33	5.4	48
32	9.0	78	2.8	25	78	690	8.4	74	12	106
40	18	156	6.1	54	156	1380	18	159	24	212
50	34	304	12	106	294	2600	34	300	48	425
65	78	694	26	230	549	4860	64	566	84	743
80	147	1300	51	451	1078	9550	130	1150	165	1460
100	284	2500	94	743	1960	17360	250	2210	307	2720

Lubrication

As with CSF component sets, oil lubrication is preferred. Although FR sets may be used in any attitude, it is essential that the wave generator bearing and gear teeth be properly lubricated. Minimum required oil amounts are tabulated below, but the actual amount will depend on the size of the housing.

In the case of horizontal shaft installation, the appropriate oil level below the gear set center line must be maintained as tabulated. For vertical mounting, the recommended level is the center line of

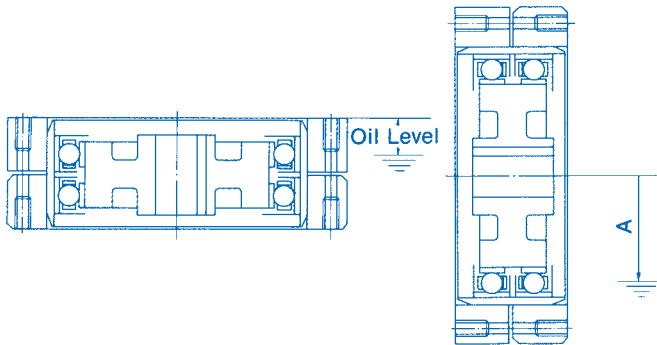

the Upper Wave generator bearing balls.

FR	14	20	25	32	40	50	65	80	100	
A	mm	7	12	15	31	38	44	62	75	94
Qty	liter	0.02	0.04	0.08	0.2	0.3	0.6	1.5	2.2	4.1
	fl.oz.	0.7	1.4	2.8	7	10	20	50	75	140

Oil Level and Minimum Oil Quantity

Oil Temperature

In normal use, the oil temperature must not exceed 90°C, as oil loses its lubricating capability quickly above this limit.

Oil Change

The first change should be performed after 100 hours of operation. The need to perform subsequent oil changes will depend on operating conditions, but should take place at intervals of approximately 1,000 running hours.

Calculation Example

This formula is used to find the total wind-up (θ) at the output of an FR 25 ratio 100:1, when a torque load of 600 lb-in is applied.

$$\begin{aligned} \theta &= \frac{T_1}{K_1} + \frac{T_2 - T_2}{K_2} + \frac{600 - T_2}{K_3} + \text{Backlash} \\ &= \frac{43}{14 \times 10^4} + \frac{330 - 43}{33 \times 10^4} + \frac{600 - 330}{48 \times 10^4} + \text{Backlash} \\ &= 17.4 \times 10^{-4} \text{ rad} + \text{Backlash} \end{aligned}$$

Grease Lubrication

FR component sets may be operated with grease lubrication at rated torque but at reduced duty cycle. Imperial Molub Alloy No. 2 is recommended.

Grease lubrication may be used in applications where the duty cycle is less than 10 percent time-on and the length of time-on does not exceed 10 minutes of continuous operation. The maximum input speeds allowable for units lubricated by Molub Alloy No. 2 are given below:

FR	14	20	25	32	40	50	65	80	100
S	24.5	38	48	63	76	95	126	152	190

Harmonic Grease HC-1

As a result of an extensive search for a grease that will render improved performance in harmonic drive component sets, a new grease, named Harmonic Grease HC-1, has been developed. With Harmonic grease HC-1, **units may be operated continuously.**

An important consideration in grease lubrication is ensuring that as much grease as possible is retained where lubrication is needed. To achieve this, it is recommended that the axial location surfaces at D width extend radially inward to the dimension shown. However, such an extension is not recommended for oil lubrication.

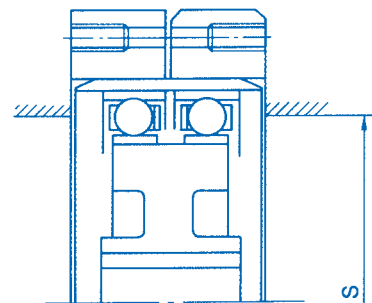

FR	14	20	25	32	40	50	65	80	100
S	24.5	38	48	63	76	95	126	152	190

Grease Changes

When operating the FR at rated torque, change grease after about 1,000 running hours. Light duty operation may permit longer service intervals. To change grease, Completely disassemble and clean units before re-greasing. Apply grease generously inside the Flexspline, the Wave generator bearing,

and teeth of both the Circular and Dynamic Splines and the Flexspline.

The approximate amount of grease needed for each Harmonic Drive FR Component Set is tabulated below:

FR		14	20	25	32	40	50	65	80	100
Grease Weight	gr.	8	18	30	60	100	150	320	570	1150
	oz.	0,3	0,6	1	2	3,5	5,5	11	20	40

Installed Relationship and Recommended Tolerances for Housing

The Dynamic Spline is distinguished by its chamfered outer edge. FR component sets may be operated in any attitude with suitable bearing support of the input and output shaft, and a means of fixing the Circular

Spline against rotation. Recommended installed relationships for the Series R units, (recommended for robotics application) are shown below:

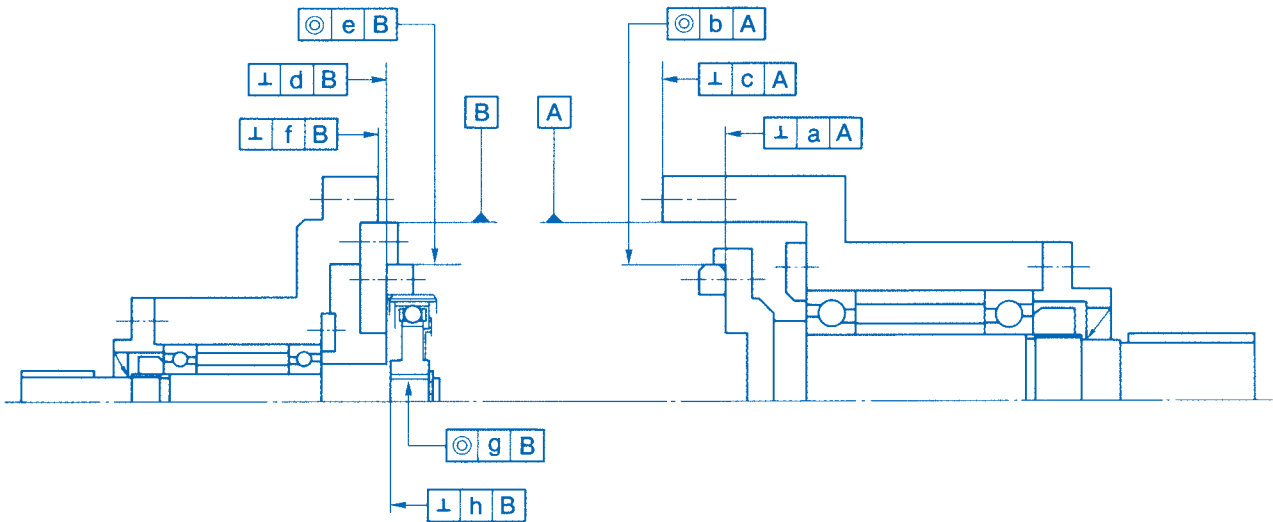

FR	a	b	c	d	e	f	g	h
14	0.013	0.015	0.016	0.013	0.015	0.016	0.011	0.007
20	0.017	0.016	0.020	0.017	0.016	0.020	0.013	0.010
25	0.024	0.016	0.029	0.024	0.016	0.029	0.016	0.012
32	0.026	0.017	0.031	0.026	0.017	0.031	0.016	0.012
40	0.026	0.019	0.031	0.026	0.019	0.031	0.017	0.012
50	0.028	0.024	0.034	0.028	0.024	0.034	0.021	0.015
65	0.034	0.027	0.041	0.034	0.027	0.041	0.025	0.015
80	0.043	0.033	0.052	0.043	0.033	0.052	0.030	0.015
100	0.057	0.038	0.068	0.057	0.038	0.068	0.035	0.015

Efficiency

Efficiency varies depending on input speed, ratio, load level, temperature, and type of lubrication. The effect of these factors are illustrated in the curves shown.

Efficiency vs. Speed, Temperature, Reduction Ratio, and oil Lubrication

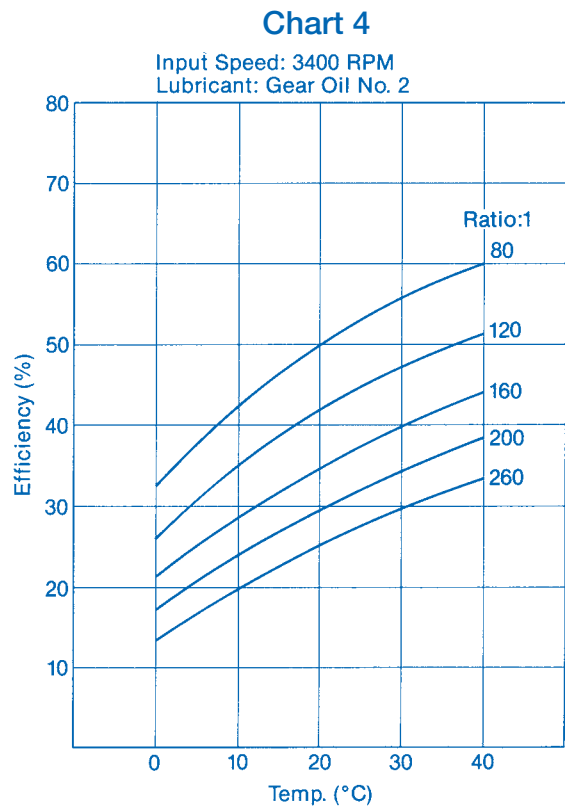
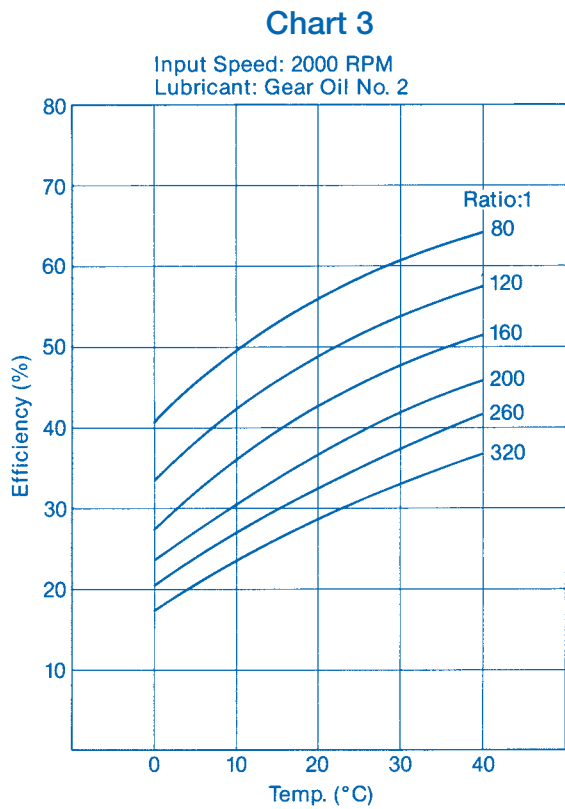
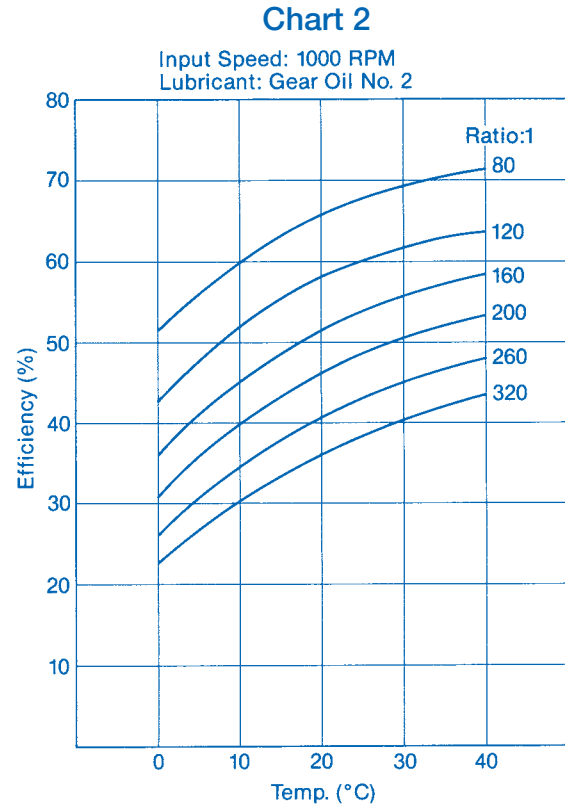
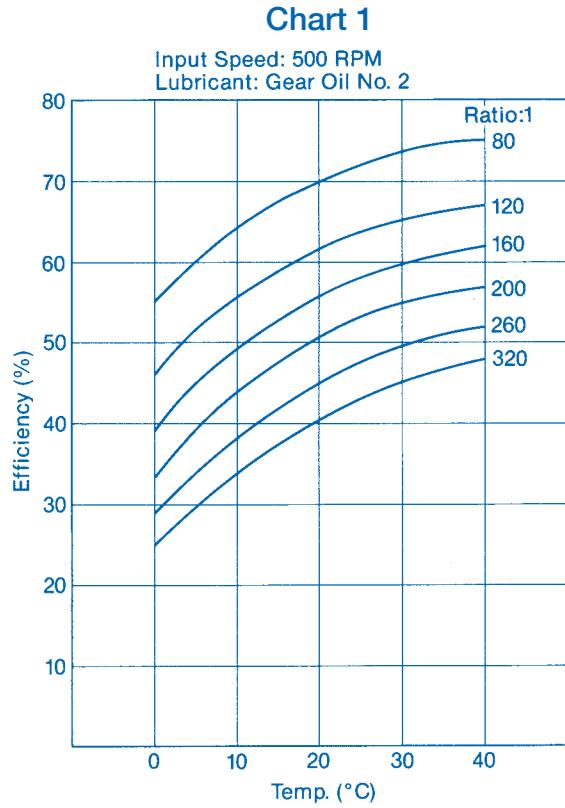

Efficiency (cont.)

Chart 5

Input Speed: 500 RPM
Lubricant: Harmonic Grease HC-1

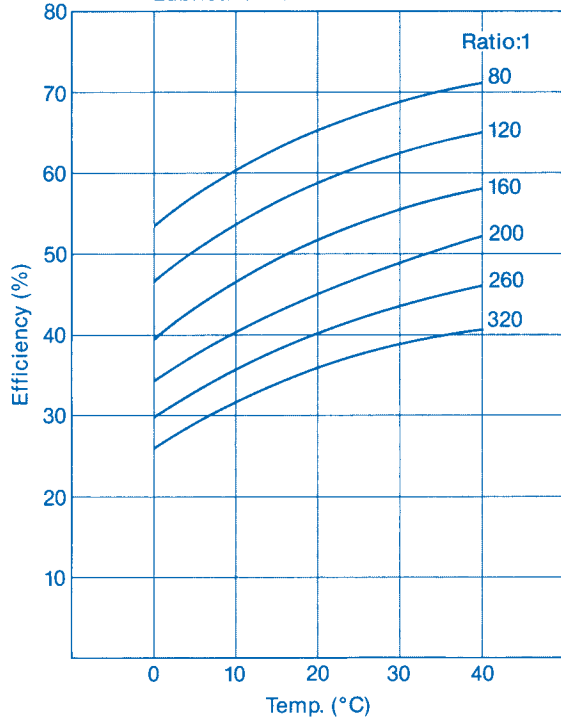

Chart 6

Input Speed: 1000 RPM
Lubricant: Harmonic Grease HC-1

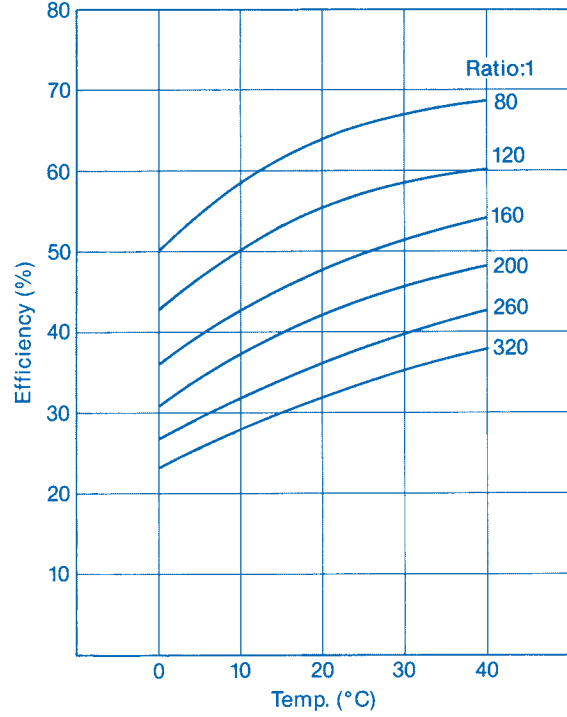

Chart 7

Input Speed: 2000 RPM
Lubricant: Harmonic Grease HC-1

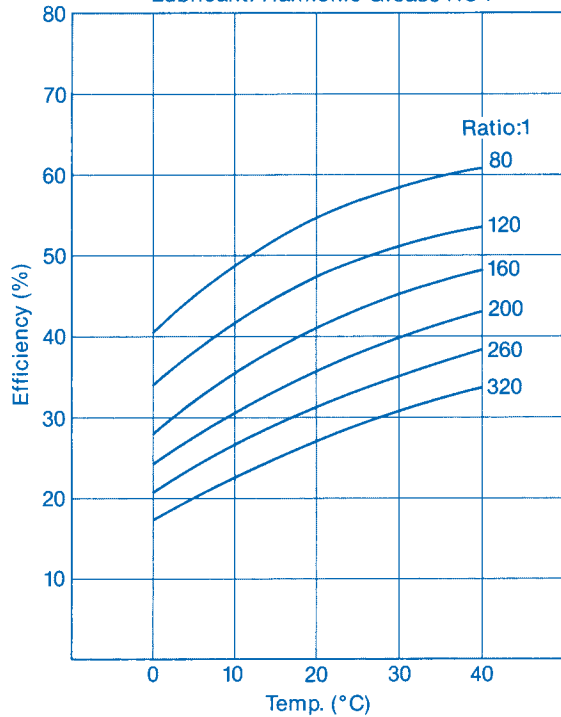
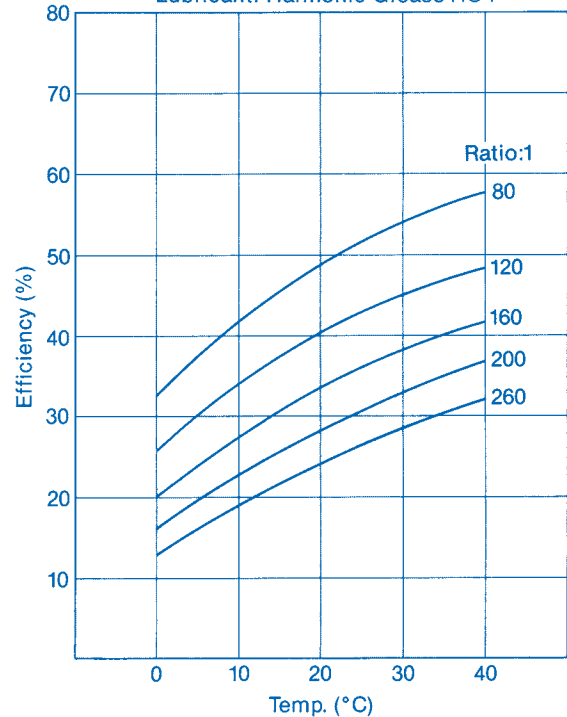

Chart 8

Input Speed: 3400 RPM
Lubricant: Harmonic Grease HC-1



Efficiency vs. Load

Efficiency of the harmonic drive transmissions vary depending on output torque. The efficiency curves given on the preceding pages are for units operating at an output torque rated for 2,00 rpm. Efficiency

of a unit operating at a load below the rated torque may be estimated using a compensation curve and formula shown below.

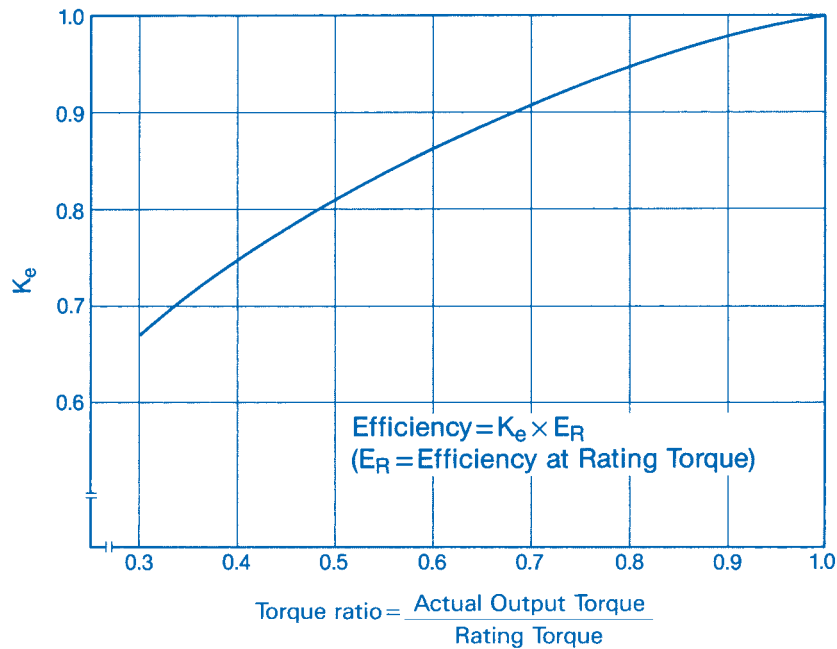

Ex. Efficiency of an FR 40-160-2GR operating at an input speed of 1,00 rpm, output torque of 1,560 lb-in, and at 40°C may be estimated as follows:

$$\text{Torque ratio} = \frac{1,560}{2,600} = 0.6$$

$$K_e = 0.87$$

$$\text{Efficiency (at 1,560 lb-in)} = 58 \times 0.87 = 50\%$$

No-Load Starting Torque and Backdriving Torque

FR		14	20	25	32	40	50	65	80	100
Starting Torque	Ncm	0.7~4	0.7~6	0.7~20	1~30	3~50	4~100	7~200	28~280	98~680
	oz-in	1~5	1~8	1~28	1.4~42	4.2~70	5~140	10~280	40~400	140~970
Backdriving Torque	Nm	0.7~10	1~19	3~48	4~80	7~190	15~340	30~480	48~790	290~2500
	lb-in	6~90	9~170	26~430	35~700	60~1700	130~3000	260~4300	430~7000	2600~22000

Values quoted are based on actual tests with the component sets assembled in their housings, and inclusive of friction resistance of oils seals, and churning of oil.

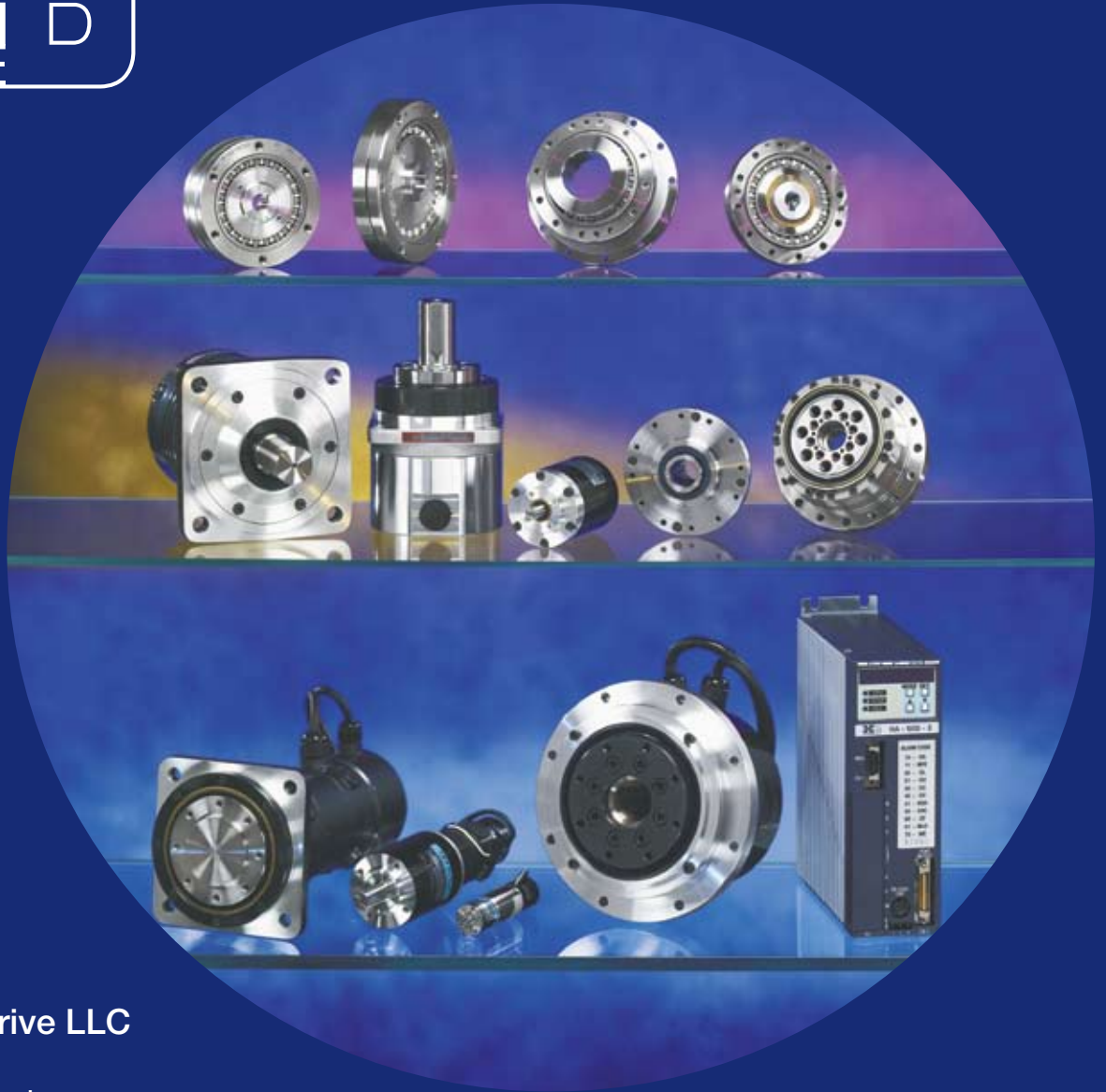

Harmonic Drive LLC

Boston

247 Lynnfield Street
Peabody, MA 01960

New York

89 Cabot Court
Hauppauge, NY 11788

800-921-3332

F: 978-532-9406

www.HarmonicDrive.net

Worldwide Locations:

Harmonic Drive Systems, Inc.
Minamiohi 6-25-3, Shinagawa-ku
Tokyo 140, Japan

Harmonic Drive AG
Hoenbergstr, 14
Limburg/Lahn, D-65555 Germany