

Harmonic Drive LLC

Precision Actuators • Gearheads • Gearing Components



Total
Motion
Control



Excellent Technology for Evolving Industries

Harmonic Drive™ actuators utilize high-precision, zero-backlash Harmonic Drive™ precision gears and play critical roles in robotics, semiconductor manufacturing equipment, factory automation equipment, medical diagnostics and surgical robotics. Additionally, our products are frequently used in mission-critical spaceflight applications which capture the human spirit.

We are proud of our outstanding engineering capabilities that have led to the development of our product line of high performance actuators. We also provide high precision, customer specific solutions to meet application requirements.

Harmonic Drive LLC continues to develop enabling technologies for the evolving motion control market, which drives the pace of global innovation.

Harmonic Drive™ High-Precision Strain Wave Gearing

Features

- High positioning accuracy
- High repeatability
- Compactness
- Light weight, High reduction ratio,
- High torque capacity
- Zero Backlash
- High efficiency
- Quiet operation

Structure

Utilizing a unique operating principle, the gear consists of only 3 basic parts (Wave Generator, Flexspline, and Circular Spline). It provides excellent features not found in other speed reducers.

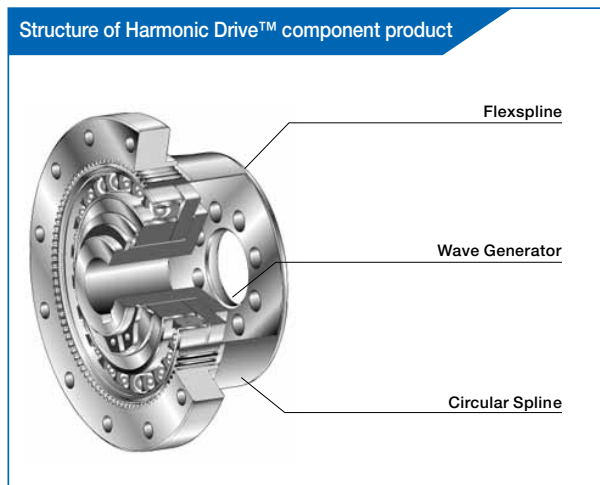

Wave Generator

The Wave Generator is a thin raced ball bearing fitted onto an elliptical hub. This serves as a high efficiency torque converter and is generally mounted onto the input or motor shaft.

Flexspline

The Flexspline is a non-rigid, thin cylindrical cup with external teeth on the open end of the cup. The Flexspline fits over the Wave Generator and takes on its elliptical shape. The Flexspline is generally used as the output of the gear.

Circular Spline

The Circular Spline is a rigid ring with internal teeth. It engages the teeth of the Flexspline across the major axis of the Wave Generator ellipse. The Circular Spline has two more teeth than the Flexspline and is generally mounted onto a housing.

Operating Principle

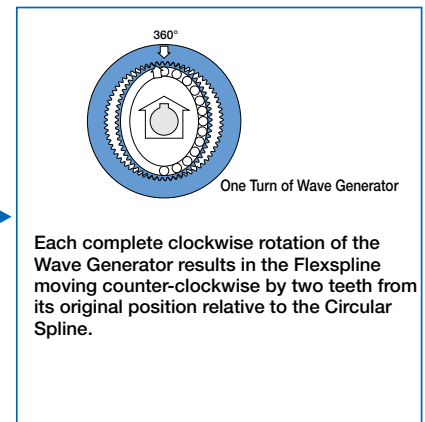
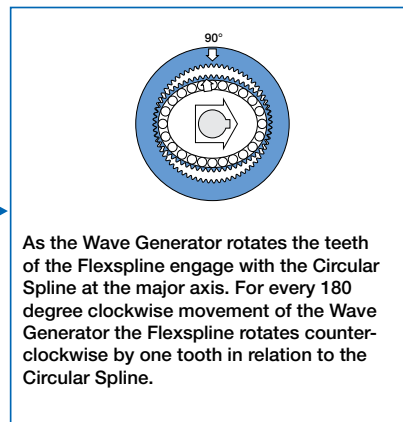
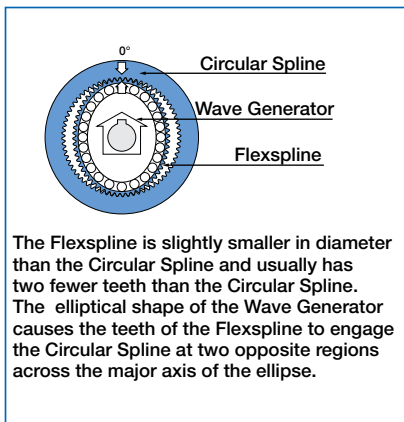

Tooth engagement

The strain wave gear has a unique tooth engagement which results in a Zero-backlash gear mesh that provides high positional accuracy and high torque with a compact form factor.

The Harmonic Drive™ strain wave gear utilizes a unique gear tooth profile which is optimized for its unique tooth engagement. Unlike an involute tooth profile, which is used in conventional gears, this optimized tooth profile ("IH tooth") enables about 30% of the total number of teeth to be engaged at the same time. This technological innovation results in high torque, high torsional stiffness, long life and smooth rotation.

The "IH" tooth profile eliminates stress concentration by widening the tooth root and providing a large tooth root radius. This figure shows the progression of the Flexspline tooth engagement as it meshes with the teeth of the fixed Circular Spline.

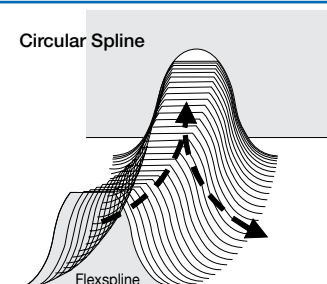



Actuators

Rotary Actuators

AC Servomotors

- Miniature Flat Hollow Shaft **FHA-Cmini**
- Flat Hollow Shaft **FHA-C**
- Flat Hollow Shaft **SHA**
- Ultra Compact Cylinder Type **RSF Supermini**
- Compact Cylinder Type **RSF mini**
- Compact Cylinder Type **RSF**
- Compact Cylinder Type **RKF**

Specification (range)	
Peak Torque (Nm)	Maximum Speed (rpm)
1.8~28	60~200
39~820	22~96
127~3419	17.4~109.8
0.13~1.4	100~333
1.8~28	60~200
34~330	45~90
56~330	45~90

DC Servomotors

- Compact Cylinder Type **RH**

Variation	
Peak Torque (Nm)	Maximum Speed (rpm)
0.39~20	50~180

Direct Drive Motor

- Ultra Precision Direct Drive Motor **KDU**

Variation	
Peak Torque (Nm)	Maximum Speed (rpm)
7.0~15.0	160~180

Linear Actuators

AC Servomotor Driven

- High-Force Positioning Type **LBC**

Variation		
Maximum Driving Force (N)	Maximum Speed (mm/s)	Stroke (mm)
6000~12000	10~20	50

DC Servomotors Driven

- Low-Force Positioning Type **LA**
- Medium-Force Positioning Type **LAH-46**
- Low-Force Positioning Type **LNP**

49	0.9	10~30
392	3.7	10~30
100 or 10kg	10	50

Stepping Motors Driven

- High-Force Positioning Type **LAH-80**

3000	3000	0.9~10
------	------	--------

Custom Actuator

Optical Galvano Scanners

- High Accuracy, High Response

LSA

Moment of Inertia (g.cm ²)	Torque Constant (N·m/A)
1.9~8.5	0.0082~0.05

Sensors

- Super-compact Encoders, Micro Encoders

Micro Encoder

Control Systems

Servo Drivers

DC Digital Servo Drive

- Multiple Operating Modes **DCJ Series**
- Multiple Operating Modes **DDP Series**
- Multiple Operating Modes **DEP Series**

AC Digital Servo Drive

- Multiple Communication Modes **RTL Series**
- Multiple Operating Modes **REL Series**

For AC Servomotors

- Position and Speed Control **HA-720 Series**
- Position and Speed Control **HA-680 Series**
- Position and Speed Control **HA-655 Series**
- With 1 Axis Control Function **HA-675 Series**

For DC Servomotors

- Position and Control Only **HS-360 Series**

Pulse Position Command	Analog Speed Command	Mono-shaft Control (Command)	Interface to Absolute Encoder	Interface to Incremental Encoder
•	•	•	–	•
•	•	•	–	•
–	•	•	•	•
•	•	•	–	•
•	•	•	•	•
•	•	–	–	
•	•	–	–	
•	•	–	•	•
–	–	•	•	•
•	–	–	–	•

The combinations with actuator and driver may not comply with foreign safety standards. Please contact our sales office.



FHA-C mini (Page 8)



FHA-C (Page 9)



SHA (Page 10)



RSF Supermini (Page 12)



RSF Mini (Page 13)



RSF (Page 14)



RKF (Page 15)



RH (Page 16)



KDU (Page 17)



LBC (Page 18)



LA (Page 19)



LAH-46 (Page 20)



LAH-80 (Page 20)



LNP (Page 21)



LSA (Page 22)



Micro Encoder (Page 23)



DDP
(Pages 24-25)



DCJ
(Pages 24-25)



DEP
(Pages 24-25)



RTL/REL
(Pages 24-25)



HA-655/HA-675
(Pages 27)



HA-680
(Pages 26)



HA-720
(Pages 26)



HS-360
(Pages 27)

Product Feature

Drive System

Speed Reducers

Strain Wave Gearing

Harmonic Drive™ precision product

Component / Cup Type

Cup Type

High-torque Type

CSG

Super Flat Type

CSD

Standard Type

CSF

Silk Hat Type

High-torque Type

SHG

Standard Type

SHF

Pancake Type

Standard Type

FB

Standard Type

FR

Standard Type

HBD

Component Sets

These products consist of the three basic components (F/S, W/G, C/S). They often provide the greatest design flexibility.

Unit Type

Unit Type

Component sets are integrated with a housing and combined with a precision cross roller bearing for the output flange, providing a robust design that is easy to use.

High-torque Type

CSG-2UH

Standard Type

CSF-2UH

High-Torque Hollow Shaft Type

SHG-2UH

Hollow Shaft Type

SHF-2UH

High-Torque Hollow Shaft Type

SHG-2UJ

Shaft Input Type

SHF-2UJ

Compact Type

CSF-2XH

Compact Double Shaft Type

CSF-1U

Flat Type

CSD-2UH

Simple Unit Type

Simplicity Unit Type

Component sets are combined with a precision cross roller bearing at the output. The housing is provided by the customer's machine structure.

High-Torque Hollow Shaft Type

SHG-2SH

Flat Hollow Shaft Type

SHF-2SH

High-torque Flat Type

SHG-2SO

Flat Type

SHF-2SO

Super Flat Hollow Shaft Type

SHD-2SH

Flat Type

CSD-2UF

Phase Adjustment Unit

Standard Type

FD

Standard Type

HDI

Variation

Peak Torque (Nm)	Reduction Ratio
23~3400	1/50~1/160

12~820	1/50~1/160
--------	------------

1.8~9200	1/30~1/160
----------	------------

23~3400	1/50~1/160
---------	------------

9.0~1800	1/30~1/160
----------	------------

3.2~510	1/50~1/160
---------	------------

5.4~8000	1/50~1/320
----------	------------

28~655	1/80~1/160
--------	------------

Variation

Peak Torque (Nm)	Reduction Ratio
23~3400	1/50~1/160

9.0~2600	1/30~1/160
----------	------------

23~3400	1/50~1/160
---------	------------

9.0~1800	1/30~1/160
----------	------------

23~3400	1/50~1/160
---------	------------

9.0~1800	1/30~1/160
----------	------------

0.5~28	1/30~1/100
--------	------------

0.13~28	1/30~1/100
---------	------------

12~280	1/50~1/160
--------	------------

Variation

Peak Torque (Nm)	Reduction Ratio
23~3400	1/50~1/160

9.0~1800	1/30~1/160
----------	------------

23~3400	1/50~1/160
---------	------------

9.0~1800	1/30~1/160
----------	------------

12~450	1/50~1/160
--------	------------

12~450	1/50~1/160
--------	------------

Variation

Peak Torque (Nm)	Reduction Ratio
30~4000	1/50~1/320

100~500	1/100
---------	-------



Planetary Gearing

Gear Head Type

Small and Medium-capacity Type

CSF-GH

Small Capacity Type

CSF-2XH

Gear Head Type

Small and Medium-capacity Type

HPG

HPG Right Angle

Variation

Peak Torque (Nm)	Reduction Ratio	Motor Capacity (W)
18~2600	1/50~1/160	30~5000

0.5~28	1/30~1/100	3~30
--------	------------	------

7.8~2200	1/5~1/45	30~10000
----------	----------	----------

150~2000	1/5~1/45	1000~7500
----------	----------	-----------



CSG (Page 29)



CSD (Page 30)



CSF (Page 31)



SHF (Page 33)
SHG (Page 32)



FB (Page 42)



FR (Page 42)



HDB (Page 45)



CSG-2UH (Page 34)



CSF-2UH (Page 35)



SHF-2UH (Page 37)
SHG-2UH (Page 36)

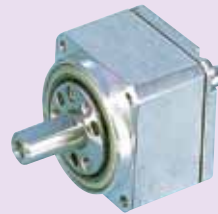

CSF-1U, 2XH (Page 38)



CSD-2UH (Page 39)



SHD-2SH (Page 41)



SHG-2SH (Page 34)



CSD-2UF (Page 40)



FD Series Unit Type (Page 43)



FD Series Component Type (Page 44)



HDI Infnit-Indexer (Page 49)



CSF-GH (Page 46)



HPG (Page 47)



HPG RA (Page 48)

Hollow Shaft Brushless Actuators FHA-C Mini Series



These servo actuators utilize precision Harmonic Drive™ precision gear combined with a performance matched brushless servo motor and incremental encoder. The cube shaped form factor is very compact and features a through hole in the center of the shaft. This hollow shaft may be used to pass cables, tubing or a laser beam through the axis of rotation.

The FHA-mini series is designed to operate with a wide range of third-party drivers, as well as Harmonic Drive LLC's DDP Series, DCJ Series, DEP Series, HA655 and HA675 drivers.

- Large Center Through Hole
- Compact Design
- Body width from 50 mm to 75mm
- Body length from 48.5 mm to 66 mm

•FHA-C mini Series Ratings

Item		Model	FHA-8C			FHA-11C			FHA-14C		
Gear Ratio			30	50	100	30	50	100	30	50	100
Maximum Torque ^{※2}	N•m		1.8	3.3	4.8	4.5	8.3	11	9	18	28
	in-lb		15.9	29.2	42.5	39.8	73.5	97.4	79.7	159.3	247.8
Maximum Positioning Speed		r/min	200	120	60	200	120	60	200	120	60
Torque Constant 100V, 200V	N•m/A		3.9	6.7	14	3.8	6.6	13	4.2	7.2	15
	in-lb/A		34.5	59.3	123.9	33.6	58.4	115.1	37.2	63.7	132.8
Torque Constant 24V	N•m/A		0.8	1.3	2.7	0.8	1.3	2.6	0.8	1.4	2.9
	in-lb/A		7.1	11.5	23.9	7.1	11.5	23.0	7.1	12.4	25.7
Maximum Current ^{※2}	AC100V, 200V	A	0.61	0.64	0.48	1.5	1.6	1.1	2.9	3.2	2.4
	DC 24V		3.0	3.3	2.4	7.8	8.2	5.6	14.8	16.4	12.3
Moment of Inertia	(GD ² /4)	kg•m ²	0.0026	0.0074	0.029	0.0060	0.017	0.067	0.018	0.050	0.20
	(J)	kgf•cm•s ²	0.027	0.075	0.30	0.061	0.17	0.68	0.18	0.51	2.0
One-Way Positioning Accuracy		arc/sec	150	120	120	120	90	90	120	90	90
Permissible Moment Load	N•m		15			40			75		
	in-lb		133			354			664		
Moment Stiffness	N•m/rad		2x10 ⁴			4x10 ⁴			8x10 ⁴		
	in-lb/rad		18x10 ⁴			35x10 ⁴			71x10 ⁴		
Detector Resolution (At x 4) ^{※4}		Pulses/Revolution	240,000	400,000	800,000	240,000	400,000	800,000	240,000	400,000	800,000
Power Supply		V	DC 24, AC 100, AC 200								
Weight		kg	0.40			0.62			1.2		
Protection			Totally closed, self-cooling (Equivalent to IP44)								
Environmental Conditions			Operating temperature: 0 to 40°C • Storage temperature: -20 to +60°C. Operating and storage humidity: 20 to 80% RH (No condensation permitted). Vibration resistance : 25m/s ² (frequency: 10 to 400Hz) • Shock resistance: 300m/s ² . Indoor installation: No dust, no metal powder, no corrosive gas, no inflammable gas, no oil mist, no other foreign matter and no direct sunshine. Altitude 1000m or less. Insulation resistance: 100MΩ or higher (DC 500V). Dielectric strength: AC 1500V/1min. Insulation class: Class B								
Servo Drive Combinations	DC24V		DCJ-055-09/DDP-090-09/DEP-090-09			DCJ-055-18/DDP-090-18/DEP-090-18			DDP-090-36/DEP-090-36		
	AC100/200		RTL-230-18/REL-230-18								
	100V.200V		HA-655-1/HA-675-1								

- 1 The figures in the table are those at the output shaft.
- 2 The figures are measured when combined with an HA-655 servo driver.
- 3 The figures are typical values.

- 4 The quad encoder resolution is obtained by the formula (motor encoder resolution) x4 x (reduction ratio)

Unit: mm

Model of Actuator	A	B	øC	øD
FHA-8C	50	48.5	33.5	6.2
FHA-11C	60	56	41	8
FHA-14C	75	66	52.5	13.5

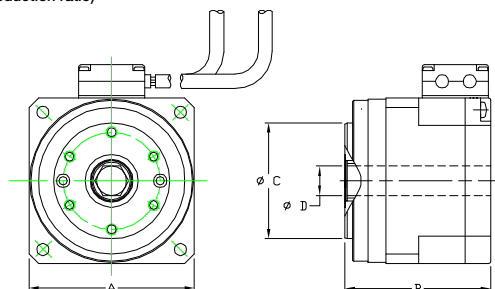

Drawings (DXF) can be downloaded from our home page. URL: <http://HarmonicDrive.net>

Hollow Shaft Brushless Actuators FHA-C Series



These servo actuators utilize precision Harmonic Drive™ precision gear combined with a performance matched brushless servo motor and incremental encoder. Absolute encoders are also available as an option. The FHA has a low profile form factor and features a hollow shaft through the center of the output. This hollow shaft feature may be used to pass cables, tubing or a laser beam through the axis of rotation.

The FHA series is designed to operate with a wide range of third-party drivers, as well as Harmonic Drive LLC's DDP Series, DEP Series, RTL Series, HA655 and HA675 drivers.

- High torque
- Large center through hole
- Compact cylindrical design

•FHA-C Series Ratings

Item		Model			FHA-17C			FHA-25C			FHA-32C			FHA-40C			
Gear Ratio		50	100	160	50	100	160	50	100	160	50	100	160	50	100	160	
Maximum Torque* ²	N•m	39	57	64	150	230	260	281	398	453	500	690	820				
	in-lb	345	504	566	1328	2036	2301	2487	3522	4009	4425	6107	7257				
Maximum Rotational Speed		r/min	96	48	27	90	45	28	80	40	25	70	35	22			
Torque Constant	N•m/A	21	42	67	22	45	72	27	54	86	31	64	102				
	in-lb/A	186	372	593	195	398	637	239	478	761	274	566	903				
Maximum Current* ³		A	2.1	1.6	1.1	7.3	5.6	4.0	11.4	8.0	5.9	17.3	11.8	9.0			
Moment of Inertia	(GD ² /4)	kg•m ²	0.17	0.67	1.7	0.81	3.2	8.3	1.8	7.1	18.1	4.9	19.5	50			
	(J)	kgf•cm•s ²	1.7	6.9	17	8.3	33	85	18	72	185	50	200	510			
One-Way Positioning Accuracy		arc/sec	60	40	40	40	30	30	40	30	30	40	30	30			
Permissible Moment Load	N•m	188			370			530			690						
	in-lb	1664			3275			4691			6107						
Moment Stiffness	N•m/rad	220x10 ³			490x10 ³			790x10 ³			1400x10 ³						
	in-lb/rad	1947x10 ³			4337x10 ³			6992x10 ³			12390x10 ³						
Detector Resolution (At x 4)* ⁴		Pulses/Revolution	500,000	1,000,000	1,600,000	500,000	1,000,000	1,600,000	500,000	1,000,000	1,600,000	500,000	1,000,000	1,600,000			
Power Supply		V	AC 200			AC 200			AC 200			AC 200					
Weight		kg	2.5			4.0			6.5			12					
Protection		Totally closed, self-cooling (Equivalent to IP44)															
Environmental Conditions		Operating temperature: 0 to 40°C/Storage temperature: -20 to 60°C • Operating and storage humidity: 20 to 80% RH (no condensation permitted). Insulation resistance: 100MΩ (DC 500V) • Dielectric strength: AC 1500V/1min. Vibration resistance: 24.5m/s ² (frequency: 10 to 400Hz) • Shock resistance: 294m/s ² . Indoor installation: No dust, no metal powder, no corrosive gas, no oil mist, no other foreign matter and no direct sunshine • Altitude 1000m or less.															
Servo Drive Combinations	DC24V	DDP-090-36/DEP-090-36															
	AC100	RTL-230-18/REL-230-18			RTL-230-36 REL-230-36	RTL-230-18 REL-230-18	RTL-230-36 REL-230-36	RTL-230-18 REL-230-18									
	AC200	RTL-230-18/REL-230-18									RTL-230-36 REL-230-36	RTL-230-18 REL-230-18					
		HA-655-2-200/HA-675-2-200						HA-655-4-200/HA-675-4-200									

- 1 The figures in the table are those at the output shaft.
- 2 The figures are measured when combined with an HA-655 servo driver.
- 3 The figures are typical values.
- 4 The quad encoder resolution is obtained by the formula (motor encoder resolution) x 4 x (reduction ratio)

Units: mm

Size Symbol	FHA-17C	FHA-25C	FHA-32C	FHA-40C
øA	128	155	175	230
øB	70	85	105	130
øC	18	32	35	45
D	21	25	22	30
E	78	90.5	111.5	127

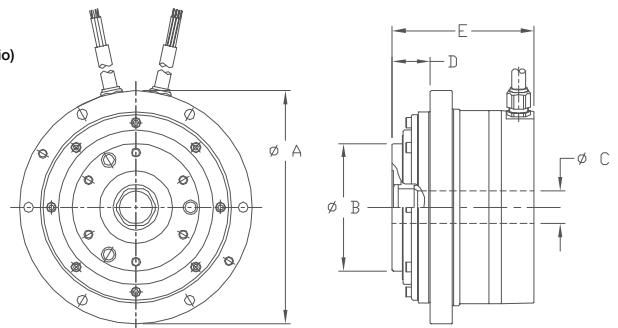

Drawings (DXF) can be downloaded from our home page. URL: <http://HarmonicDrive.net>

Hollow Shaft Brushless Actuators

SHA Series



SHA Series AC Servo Actuators provide high torque and highly accurate rotary operation.

These servo actuators utilize Harmonic Drive™ precision gears combined with a brushless servomotor and magnetic absolute encoder. The SHA Series is an advanced version of current FHA series AC Servo Actuators, having larger, hollow structure in a smaller diameter size.

The SHA Series is designed to operate with a wide range of third-party drivers, as well as Harmonic Drive LLC's REL Series and HA-800 drivers,

- High torque
- Compact, slimmed design
- Large center-through hole

•SHA Series Ratings

Item	Model	SHA25A					SHA32A				
		51	81	101	121	161	51	81	101	121	161
Gear Ratio		51	81	101	121	161	51	81	101	121	161
Maximum Torque <small>Note 2</small>	N•m	127	178	204	217	229	281	395	433	459	484
	in-lb	1124	1575	1805	1920	2027	2487	3496	3832	4062	4283
Maximum Rotational Speed	r/min	109.8	69.1	55.4	46.3	34.8	94.1	59.3	47.5	39.7	29.8
Torque Constant	N•m/A(rms)	19	31	39	46	62	21	33	42	50	66
	in-lb/A(rms)	168	274	345	407	549	186	292	372	443	584
Maximum Current <small>Note 2</small>	A(rms)	8.6	7.5	7.0	6.3	5.2	17.3	15.2	13.5	12.2	9.9
Moment of Inertia $GD^2/4$ (without brake) J	kg•m ²	0.56	1.42	2.2	3.2	5.6	2.0	5.1	8.0	11	20
	kgf•cm•s ²	5.7	14.4	22	32	57	21	52	81	17	207
Moment of Inertia $GD^2/4$ (with brake) J	kg•m ²	0.66	1.66	2.6	3.7	6.6	2.3	5.9	9.2	13	23
	kgf•cm•s ²	6.7	17	26	38	67	24	60	94	135	238
One-Way Positioning Accuracy	arc•sec	50	40	40	40	40	50	40	40	40	40
Permissible Moment Load	N•m	258					580				
	in-lb	2283					5133				
Moment Stiffness	N•m/rad	39.2 x 10 ⁴					100 x 10 ⁴				
	in-lb/rad	346.9 x 10 ⁴					885 x 10 ⁴				
Output Resolution	Pulses/Revolution	6,684,672	10,616,832	13,238,272	15,859,712	21,102,592	6,684,672	10,616,832	13,238,272	15,859,712	21,102,592
Mass (without brake)	kg	2.95					5.9				
Mass (with brake)	kg	3.1					6.2				
Protection Structure		Totally enclosed self-cooled type (equivalent to IP54)									
Environmental Conditions		Operating temperature: 0 to 40°C • Storage temperature: -20 to +60°C. Operating and storage humidity: 20 to 80% RH (No condensation permitted). Vibration resistance : 25m/s ² (frequency: 10 to 400Hz) • Shock resistance: 300m/s ² . Indoor installation: No dust, no metal powder, no corrosive gas, no inflammable gas, no oil mist, no other foreign matter and no direct sunshine. Altitude 1000m or less. Insulation resistance: 100MΩ or higher (DC 500V). Dielectric strength: AC 1500V/1min. Insulation class: Class E									
Servo Drive Combinations AC-200V		REL-230-18					REL-230-18, REL-230-36				
Combined Drivers		HA-800-3D					HA-800-6D				

Note 1: The table shows typical output values of actuators.

Note 2: When combined with a HA-800 driver.

Note 3: Encoder Type: Magnetic absolute encoder. Single Motor Revolution Encoder Resolution: 2¹⁷ (313,072). Motor Multi Revolution Counter: 2¹⁶ (65,536) (Battery back-up).

SHA Series Ratings

Item	Model	SHA40A					SHA58A				SHA65A			
		51	81	101	121	161	81	101	121	161	81	101	121	161
Gear Ratio		51	81	101	121	161	81	101	121	161	81	101	121	161
Maximum Torque <small>Note 2</small>	N•m	523	675	738	802	841	1924	2067	2236	2392	2400	2990	3263	3419
	in-lb	4629	5974	6531	7098	7443	17027	18293	19789	21169	21240	26462	28878	30258
Maximum Rotational Speed	r/min	78.4	49.4	39.6	33.1	24.8	37.0	29.7	24.8	18.6	34.6	27.7	23.1	17.4
Torque Constant	N•m/A(rms)	25	41	51	61	81	54	68	81	108	54	68	81	108
	in-lb/A(rms)	221	363	451	540	717	478	602	717	956	478	602	717	956
Maximum Current <small>Note 2</small>	A(rms)	26.7	21.8	19.4	17.9	14.6	45	39	36	30	55	55	51	41
Moment of Inertia $GD^2/4$ (without brake) J	kg•m ²	5.0	13	20	28	50	96	149	214	379	110	171	245	433
	kgf•cm•s ²	51	130	202	290	513	980	1520	2180	3870	1120	1740	2500	4420
Moment of Inertia $GD^2/4$ (with brake) J	kg•m ²	6.1	15	24	34	61	106	165	237	420	120	187	268	475
	kgf•cm•s ²	62	157	244	350	619	1090	1690	2420	4290	130	1910	2740	4850
One-Way Positioning Accuracy	arc•sec	50	40	40	40	40	40	40	40	40	40	40	40	40
Permissible Moment Load	N•m	849					2,180				2,740			
	in-lb	7514					19293				24249			
Moment Stiffness	N•m/rad	179 x 10 ⁴					531 x 10 ⁴				741 x 10 ⁴			
	in-lb/rad	1584.2 x 10 ⁴					4699.4 x 10 ⁴				6557.9 x 10 ⁴			
Output Resolution	Pulses/Revolution	6,684,672	10,616,832	13,238,272	15,859,712	21,102,592	10,616,832	13,238,272	15,859,712	21,102,592	10,616,832	13,238,272	15,859,712	21,102,592
Mass (without brake)	kg	9.9					29.5				37.5			
Mass (with brake)	kg	10.7					32				40			
Protection Structure		Totally enclosed self-cooled type (equivalent to IP54)												
Environmental Conditions		Operating temperature: 0 to 40°C • Storage temperature: -20 to +60°C. Operating and storage humidity: 20 to 80% RH (No condensation permitted). Vibration resistance : 25m/s ² (frequency: 10 to 400Hz) • Shock resistance: 300m/s ² . Indoor installation: No dust, no metal powder, no corrosive gas, no inflammable gas, no oil mist, no other foreign matter and no direct sunshine. Altitude 1000m or less. Insulation resistance: 100MΩ or higher (DC 500V). Dielectric strength: AC 1500V/1min. Insulation class: Class E												
Servo Drive Combinations AC-200V		REL-230-36, REL-230-40					-				-			
Combined Drivers		HA-800-24D					HA-800-24D				HA-800-24D			

Note 1: The table shows typical output values of actuators.

Note 2: When combined with a HA-800 driver.

Note 3: Encoder Type: Magnetic absolute encoder. Single Motor Revolution Encoder Resolution: 2¹⁷ (313,072). Motor Multi Revolution Counter: 2¹⁶ (65,536) (Battery back-up).

Units: mm

Size Symbol	SHA25A	SHA32A	SHA40A	SHA58A	SHA65A
øA	114	146	175	247	284
øB	86	114	140	203	223
øC	27	35	45	65	65
D	15.5	20	26	37	42.5
E	109	125	148	213	222

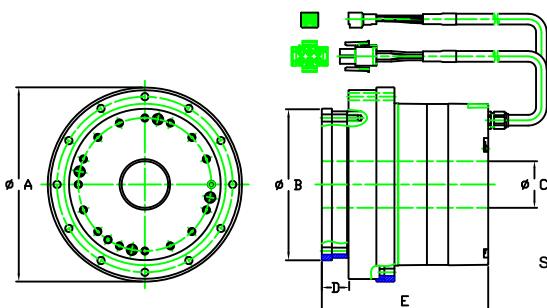

SHA25A, SHA32A, SHA40A

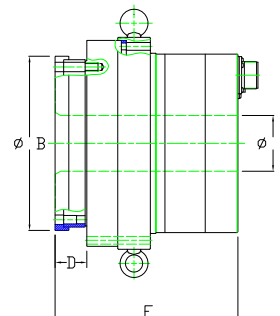

SHA58A, SHA65A

Brushless Actuators RSF-Mini Series





These brushless servo actuators utilize zero backlash Harmonic Drive™ precision gears for precise motion control. The RSF Mini Series is designed to operate with a wide range of third party drivers as well as Harmonic Drive LLC's DCJ Series, DDP Series, DEP Series, HA680 drivers.

- Exceptional Positional Accuracy
- Compact design

•RSF Mini Series Ratings

Item		Model	RSF-8B			RSF-11B			RSF-14B			
Gear Ratio			30	50	100	30	50	100	30	50	100	
Power Supply Voltage		V	DC24									
Maximum Torque (Note 3)		Nm	1.8	3.3	4.8	4.5	8.3	11	9	18	28	
		in-lb	15.9	29.2	42.5	39.8	73.5	97.4	79.7	159	248	
Maximum Speed (Note 3)		r/min	200	120	60	200	120	60	200	120	60	
Maximum Current (Note 3)		A	3.8	3.9	2.9	14.4	15.8	9.4	14.4	17.2	12.3	
Allowable Continuous Torque (Note 3,4)		Nm	0.78	1.4	2.0	1.1	2.0	4.0	1.7	3.0	6.0	
		in-lb	6.9	12.4	17.7	9.7	17.7	35.4	15.0	26.6	53.1	
Allowable Continuous Current (Note 3,4)		A	2.0	2.0	1.5	5.0	4.9	4.9	4.9	4.7	4.7	
Allowable Continuous Speed (Note 3)		r/min	100	60	30	100	60	30	100	60	30	
Torque Constant		Nm/A	0.02	1.1	2.1	0.4	0.66	1.5	0.76	1.3	2.6	
EMF Constant		V(r/min)	0.07	0.11	0.22	0.04	0.07	0.15	0.08	0.13	0.28	
Phase Resistance		Ω (25°C)	0.93			0.19			0.23			
Phase Inductance		mH	0.45			0.1			0.19			
Moment of Inertia		GD ² /4	$\times 10^{-2}$ kg·m ²	0.06	0.16	0.65	0.18	0.49	2.0	0.41	1.1	4.5
		J	$\times 10^{-2}$ kgf·cm·s ²	0.6	1.7	6.6	1.8	5.0	20	4.1	11	46
Allowable Radial Load		N	196			245			392			
		lb	44			55			88			
Allowable Thrust Load		N	98			196			392			
		lb	22			44			88			
One-Way Positioning Accuracy		arc/sec	180	150	150	150	120	120	150	120	120	
Quad Encoder Resolution (Note 6)		p/rev	120000	200000	400000	120000	200000	400000	120000	200000	400000	
Mass		kg	0.3			0.5			0.8			
Insulation Class			B									
Insulation Resistance			100M Ω (DC500V) or more									
Withstanding Voltage			AC500V/1 min									
Servo Drive Combinations		DC24V	DCJ-055-09/DDP-090-09/ DEP-090-09			DDP-090-36/DEP-090-36						
			HA-680-4B-24			HA-680-6B-24						

- Notes:
- 1) The table shows output values of the actuator.
 - 2) All specifications are applicable for actuators mounted on an aluminum heat sink of size: 150 x 150 x 6(mm)
 - 3) Values for saturated actuator temperature. Other values are for actuator temperature of 20°C.
 - 4) Values are during operation at allowable continuous rotation speed.5) All values are typical.
 - 6) Quad encoder resolution is (motor shaft encoder resolution) x 4 x (gear ratio)
 - 7) The specification above are based on using HA-680 driver.

Model	A	B	C	D	ϕ Eh7	ϕ F	G
RSF-8B	124.3	21.8	76.5	26	21	34.5	7.5
RSF-11B	141.7	25	90.7	26	24	32.5	9.5
RSF-14B	168.5	28	114.5	26	30	32.5	11.5

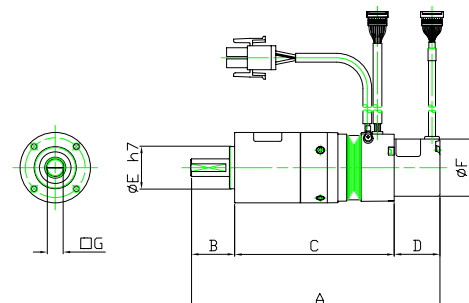

Brushless Actuators RSF Series



These compact and include high-torque AC servo actuators utilize with high rotational accuracy, a shaft output combining Harmonic Drive™ strain wave gearing for precision control and an AC servo motor. The RSF Series is designed to operate with a wide range of third party drivers as well as Harmonic Drive LLC's RTL Series, REL Series, HA-520 and HA-655 drivers.

- Compact and lightweight
- High power
- High positioning and high rotational accuracies

•RSF Series Ratings

Item	Model	RSF-17		RSF-20A		RSF-25A		RSF-32A	
Gear Ratio		50	100	50	100	50	100	50	100
Rated Output	W	62	62	120	111	180	190	310	310
Power Supply Voltage (driver)	W	AC200V							
Rated Torque	Nm	9.8	20	19	35	29	59	49	98
	inlb	87	177	168	310	257	522	434	867
Rated Rotational Speed	r/min	60	30	60	30	60	30	60	30
Continuous Stall Torque	Nm	9.8	20	19	35	29	59	49	98
	inlb	87	177	168	310	257	522	434	867
Max. Momentary Torque	Nm	34	54	56	82	98	157	220	330
	inlb	301	478	496	726	867	1389	1947	2921
Max. Rotational Speed	r/min	90	45	90	45	90	45	90	45
Moment of Inertia	(GD ² /4) kg.m ²	0.047	0.19	0.098	0.39	0.19	0.77	0.67	2.7
	(J) kgfcm ²	0.48	1.9	1.0	4.0	2.0	7.9	6.9	27
One-Way Positioning Accuracy	arc/sec	120		90		90		90	
Permissible Radial Load	N	780		1400		2900		4400	
	Lbf	175		315		652		989	
Permissible Thrust Load	N	780		1370		2900		4400	
	Lbf	175		308		652		989	
Detector Resolution *1	Pulses/ Revolution	400,000	800,000	400,000	800,000	400,000	800,000	400,000	800,000
Mass	Kg	2.1		2.9		4.7		8.7	
Servo Drive Combinations	AC200	RTL-230-18, REL-230-18							
		HA-520-1R-200 HA-655-2B-200		HA-520-1R-200 HA655-2B-200		HA-520-3-200 HA-655-2B-200		HA-655-4B-200	

Notes:

*1: The aforementioned values are those at the output shaft including the Harmonic Drive™ efficiency.

*2: The actuator specification is the value when mounted on the following aluminum radiation plate

RSF-17, RSF-20 250 x 250 x 12mm

RSF-25, RSF-32 300 x 300 x 15mm

*3: The values are those on temperature rise saturation. The other values are those at 20°C.

*4: The moment of inertia is the total of the inertia moments of the motor shaft and Harmonic Drive™ converted into the output shaft side.

*5: Detector resolution is calculated using (Motor shaft encoder resolution) x 4 x (Reduction ratio).

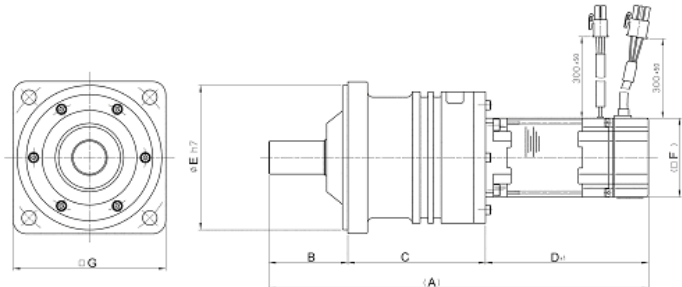

Unit: mm

Model	A	B	C	D±1	ø Eh7	□ F	□ G	Mass(kg)
RSF-17A	210	40	88	82	20	60	76	2.1
RSF-20A	242	48	98	96	85	60	93	2.9
RSF-25A	288.7	60	104.7	124	110	60	116	4.7
RSF-32A	331	80	123	128	130	80	137	8.7



These compact and include high-torque AC servo actuators utilize with high rotational accuracy, a flange output combining a speed reducer Harmonic Drive™ for precision control and an AC servo motor. The RKF Series is designed to operate with a wide range of third party drivers as well as Harmonic Drive LLC's RTL Series, REL Series, HA-520 and HA-655 drivers.

- Compact and lightweight
- High power
- High positioning and high rotational accuracies

•RKF Series Ratings

Item		Model	RKF-20A		RKF-25A		RKF-32A	
Gear Ratio			50	100	50	100	50	100
Rated Output		W	120	111	180	190	310	310
Power Supply Voltage (driver)		W	AC200					
Rated Torque		Nm	19	35	29	59	49	98
		inlb	168	310	257	522	434	867
Rated Rotational Speed		r/min	60	30	60	30	60	30
Continuous Stall Torque		Nm	19	35	29	59	49	98
		inlb	168	310	257	522	434	867
Max. Momentary Torque		Nm	56	82	98	157	220	330
		inlb	496	726	867	1389	1947	2921
Max. Rotational Speed		r/min	90	45	90	45	90	45
Moment of Inertia		(GD ² /4) kg.m ²	0.098	0.39	0.19	0.77	0.67	2.7
		(J) kgfcm ²	1.0	4.0	2.0	7.9	6.9	27
One-Way Positioning Accuracy		arc/sec	90		90		90	
Permissible Radial Load		N	2000		2500		3900	
		Lbf	450		562		877	
Permissible Thrust Load		N	880		1100		1600	
		Lbf	198		247		360	
Detector Resolution *1		Pulses/ Revolution	400,000	800,000	400,000	800,000	400,000	800,000
Mass		Kg	2.9		5.0		9.5	
Servo Drive Combinations		AC200	RTL-230-18, REL-230-18					
			HA-520-1R-200 HA655-2B-200		HA-520-3-200 HA-655-2B-200		HA-655-4B-200	

Notes:

*1: The aforementioned values are those at the output shaft including the Harmonic Drive™ efficiency.

*2: The actuator specification is the value when mounted on the following aluminum radiation plate

RKF-17, RSF-20 250 x 250 x 12mm

RKF-25, RSF-32 300 x 300 x 15mm

*3: The values are those on temperature rise saturation. The other values are those at 20°C.

*4: The moment of inertia is the total of the inertia moments of the motor shaft and Harmonic Drive™ converted into the output shaft side.

*5: Detector resolution is calculated using (Motor shaft encoder resolution) x 4 x (Reduction ratio).

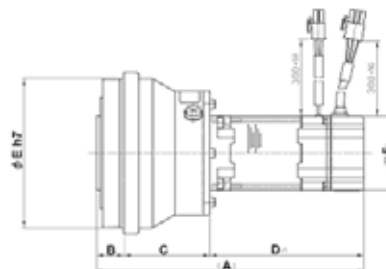
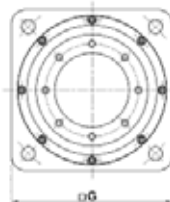

Unit: mm

Model	A	B	C	D±1	ø Eh7	□ F	□ G	Mass(kg)
RKF-20A	180	20	64	96	100	60	108	2.9
RKF-25A	215.5	22	69.5	124	120	60	130	5.0
RKF-32A	241	25.5	87.5	128	155	80	165	9.5

DC Servo Actuators RH Mini Series



This RH Mini Series is a DC servo actuator incorporating Harmonic Drive™ precision gears, a high performance brush DC servo motor and an incremental encoder.

- High Torque
- Precise Positional Accuracy
- Compact Design

•RH Series Ratings

Model		RH-5A			RH-8D		RH-11D		RH-14D	
		8802	5502	4402	6006	3006	6001	3001	6002	3002
Rated Output	W	1.5	1.7	1.4	8.6	6.2	13.6	12.3	20.3	18.5
Rated Voltage	V	12	12	12	24	24	24	24	24	24
Maximum Momentary Torque	N•m	0.39	0.59	0.69	2.7	3.5	4.9	7.8	14	20
	in-lb	3.45	5.22	6.11	23.9	31.0	43.4	60.0	123.9	177.0
Maximum Continuous Stall Torque	N•m	0.24	0.39	0.43	1.5	2.3	2.5	4.4	5.4	7.8
	in-lb	2.12	3.45	3.81	13.3	20.4	22.1	38.9	47.8	69.0
Rated Torque	N•m	0.16	0.29	0.29	1.4	2	2.2	3.9	3.2	5.9
	in-lb	1.42	2.57	2.57	12.4	17.7	19.5	34.5	28.3	52.5
Maximum Positioning Speed	r/min	180	110	90	100	50	100	50	100	50
Rated Positioning Speed	r/min	88	55	44	60	30	60	30	60	30
Maximum Momentary Current	A	0.83	0.78	0.77	1.6	1.1	2.4	2.1	5.4	4.1
Rated Current	A	0.5	0.5	0.5	1.0	0.8	1.3	1.3	1.8	1.8
Torque Constant	N•m/A	0.69	1.11	1.38	2.1	4.2	2.46	4.91	2.92	5.76
	in-lb/A	6.1	9.8	12.2	18.6	37.2	21.7	43.5	25.8	51
Moment of Inertia	kg•m ²	6.3x10 ⁻⁴	16x10 ⁻⁴	25x10 ⁻⁴	37x10 ⁻⁴	150x10 ⁻⁴	110x10 ⁻⁴	430x10 ⁻⁴	210x10 ⁻⁴	810x10 ⁻⁴
	kg•cm•s ²	0.007	0.016	0.026	0.04	0.15	0.11	0.44	0.21	0.83
One-Way Positioning Accuracy	arc/sec	290	290	290	150	150	120	120	120	120
Permissible Thrust Load	N	29	29	29	98	98	196	196	392	392
	lb	7	7	7	22	22	44	44	88	88
Reduction Ratio		50	80	100	50	100	50	100	50	100
Weight	kg	0.09	0.09	0.09	0.3	0.3	0.5	0.5	0.77	0.77
Environmental Conditions	Time constant: Continuous • Protection: Totally closed, self-cooling • Ambient temperature: 0 to 40°C Ambient humidity: 35 to 80% RH (no condensation permitted)									
Driver In Combination		HA-360-1A			HS-360-1B		HS-360-1C		HS-360-1D	

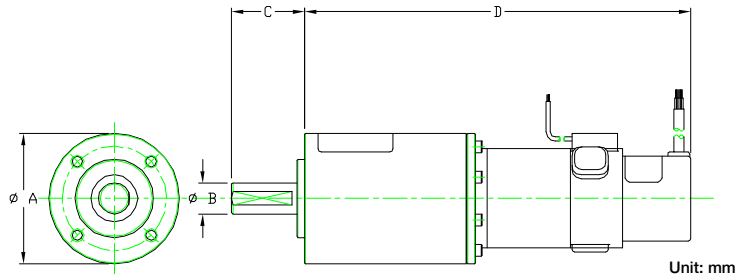

Unit: mm

Model of Actuator	øA	øB	c	D
RH-5A	20	5	11	78
RH-8D	33	8	21.8	107.2
RH-11D	40	10	25	125.2
RH-14D	50	12	28	148

Drawings (DXF) can be downloaded from our home page. URL: <http://HarmonicDrive.net>



The KDU Series are Direct Drive Motors which achieve 10 arc-sec positioning accuracy as well as ± 0.5 arc-sec Repeatability with a resolution of 0.16 arc-sec. Also, the KDU has a large Hollow Shaft design which allow cables, shafts or lasers to pass through the axis of rotation.

- Exceptional positional accuracy
- Exceptional repeatability
- Ultra high resolution

•KDU Series Ratings

Item	Model	KDU-13SA	KDU-13WA
	Maximum Torque *2	Nm	7.0
In.lb		62.0	132.8
Max. Positioning Speed	r/min	180	160
Torque Constant	Nm/A	3.1	6.5
	In.lb/A	27.4	57.5
Input Power Supply Voltage	V	AC 100	
Moment of Inertia GD2/4	kg.m2	0.0047	0.0065
Moment of Stiffness	Nm/rad	2.4×10^5	
	Inlb/rad	2.12×10^4	
Motor Position Sensor	Pulse/rev	Incremental encoder:	
		23 bits (8,388,608)	
Repeatability *3	arc sec	± 0.5	
Absolute Positioning Accuracy *3		10 *4	
Mass	kg.	4.0	5.0
Mounting Direction		Output shaft to face upward	
Combined Driver		HA-720-5-100	

*1. The table above shows output values of output shaft.

*2: The values in the table above are obtained when connected to HA-720 servo driver.

*3. The repeatability and absolute repeatability are the values measured in an environment of 23 ± 0.30 C in temperature, 50% RH in humidity and with output shaft facing upward in mounting direction. Please operate the product after checking "Precautions for maintaining accuracy" below.

*4: Value with angular position error compensation by HA-720.

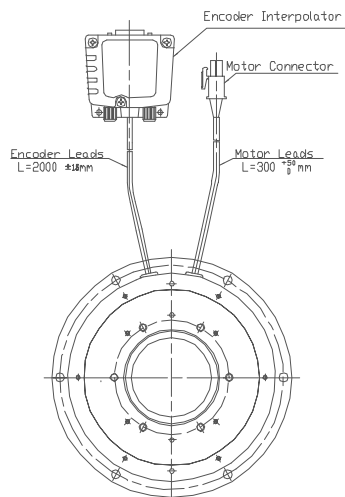

	KDU-13SA	KDU-13WA
A	80	-4

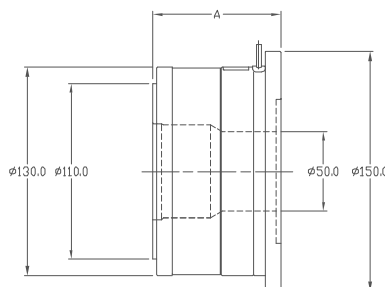

Precision Linear Actuators
LBC Series



The precision lead screw provides positioning accuracy in the micron range with sub-micron repeatability. The actuator is capable of thrust forces up to 12,000 N. This product is useful for precise positioning of heavy loads or applications where high force is required such as molding equipment or precision presses.

•LBC Series Ratings

Model	Item	Drive	Stroke (mm)	Maximum Driving Force (N)	Resolution (μm)	Maximum Speed (mm/s)	Repeatability	Outside Dimensions (mm)	Total length (mm)
LBC-25A-5D6K		Brushless Motor	50	6000	0.32	20	±5μm or less/50mm stroke	φ136	353
LBC-25A-5D12K		Brushless Motor	50	12000	0.16	10			

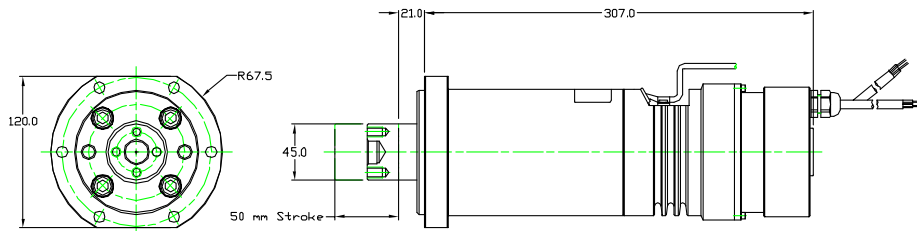

Precision Linear Actuators
LA Series



A precision ball screw provides positioning accuracy better than 2 microns and repeatability of 0.1 microns.

This product is well suited for measuring instruments, test and inspection systems, optical equipment, semiconductor and LCD manufacturing equipment.

- 49 N Force
- 2 micron positioning accuracy
- Brush DC motor with incremental encoder

•LA Series Ratings

Item Model	Drive	Stroke (mm)	Maximum Driving Force (N)	Resolution (μm)	Maximum Speed (mm/s)	Uni-directional Positioning Accuracy	Repeatability	Outside Dimensions (mm)	Total length (mm)
LA-30B-10-F	DC motor	10	49	0.0174	0.9	2 μm or less/40 μm stroke	$\pm 0.1\mu\text{m}$ or less/1mm stroke	$\varnothing 28$	143
LA-32-30-F	DC motor	30	49	0.0174	0.9			$\varnothing 36$	164

Unit: mm

Size	LA-30B-10F	LA-32-30-F
A	28	36
B(Stroke)	10	30
C	10	13.3
D	133	150.8

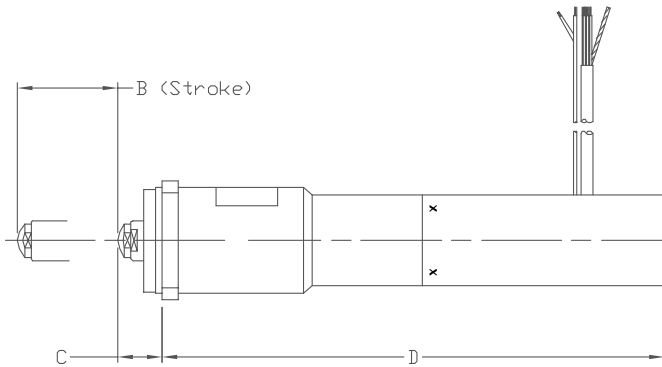
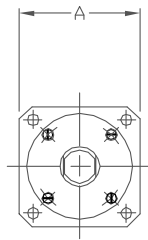

Precision Linear Actuators

LAH Series



LAH-46

LAH-80

A precision ball screw provides positioning accuracy better than 4 microns and repeatability of 1 micron.

This product is well suited for measuring instruments, test and inspection systems, optical equipment, semiconductor and LCD manufacturing equipment.

- 392 to 3000 N Force
- 4 micron positioning accuracy

•LAH Series Ratings

Model	Item	Drive	Stroke (mm)	Maximum Driving Force (N)	Resolution (μm)	Maximum Speed (mm/s)	Uni-directional Positioning Accuracy	Repeatability	Outside Dimensions (mm)	Total length (mm)
LAH-46-1002-F		DC motor	10	392	0.069	3.7	4 μm or less/.02mm stroke	$\pm 0.5\mu\text{m}$ or less/1mm stroke	$\varnothing 47$	185
LAH-46-3002-F		DC motor	30	392	0.069	3.7		$\pm 1\mu\text{m}$ or less/1mm stroke	$\varnothing 47$	204
LAH-80-5020-F-PA		Stepping motor	50	3000	2	10	4 μm or less/2mm stroke	$\pm 1\mu\text{m}$ or less/1mm stroke	$\varnothing 85$	320

Unit: mm

Model Symbol	LAH-46-1002-F	LAH-46-3002-F
A	47	47
B(Stroke)	10	30
C	16	16
D	169	188

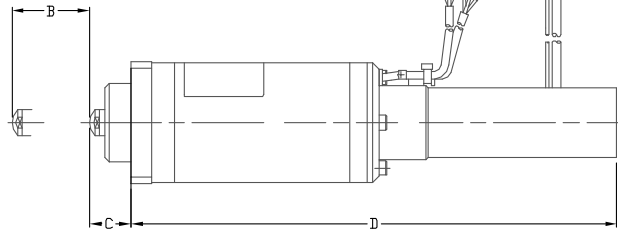
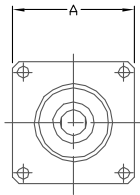

LAH-80

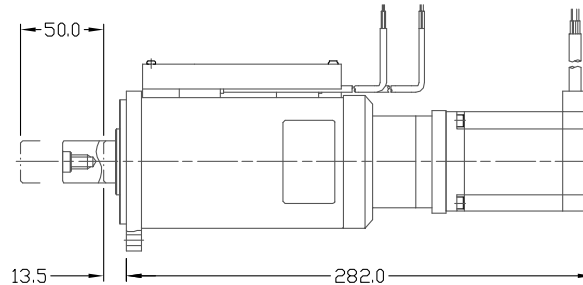
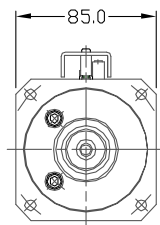

Precision Linear Actuators LNP Series

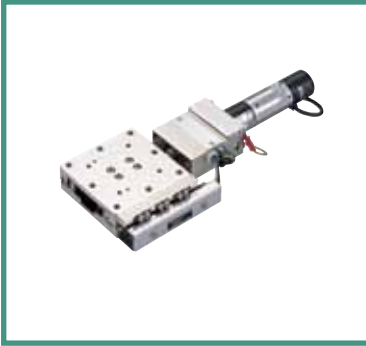

A precision lead screw provides positioning accuracy better than 6 microns and repeatability of 0.5 microns. The LNP also incorporates a high precision linear stage which enables direct mounting of a load to the actuator. Actuators can be combined for two or three axis configurations.

This product is well suited for measuring instruments, test and inspection systems, optical equipment, semiconductor and LCD manufacturing equipment.

- 10 Kg load capacity
- 6 micron positioning accuracy
- Available with Brush DC motor with incremental encoder or stepper motor

•LNP Series Ratings

Model	Item Drive	Stroke (mm)	Table Size (mm)	Load (kg)	Resolution (μm)		Maximum Speed (mm/s)		Uni-directional Positioning Accuracy	Repeatability	Total Length (mm)
LNP-4040-13	Stepping Motor	13	40x40	10	0.04	0.02	1.8	1.5	6.0μm or less	±0.5μm or less	143.3
	DC servomotor				0.056	0.028					172.5
LNP-5050-13	Stepping Motor	13	50x50	10	0.04	0.02	1.8	1.5	6.0μm or less	±0.5μm or less	153.3
	DC servomotor				0.056	0.028					182.5
LNP-6060-15	Stepping Motor	15	60x60	10	0.04	0.02	1.8	1.5	6.0μm or less	±0.5μm or less	163.3
	DC servomotor				0.056	0.028					192.5
LNP-7070-15	Stepping Motor	15	70x70	10	0.04	0.02	1.8	1.5	6.0μm or less	±0.5μm or less	173.3
	DC servomotor				0.056	0.028					202.5

Unit: mm

Model	LNP-4040-13		LNP-5050-13		LNP-6060-15		LNP-770-15	
	Step	DC	Step	DC	Step	DC	Step	DC
A	103.3	132.5	103.3	132.5	103.3	132.5	103.3	132.5
B	143.3	172.5	153.3	182.5	163.6	192.5	173.3	202.5
C	40	40	50	50	60	60	70	70
D	58.1	58.1	68.5	68.5	78.5	78.5	88.5	88.5
E	20	20	20	20	20	20	20	20

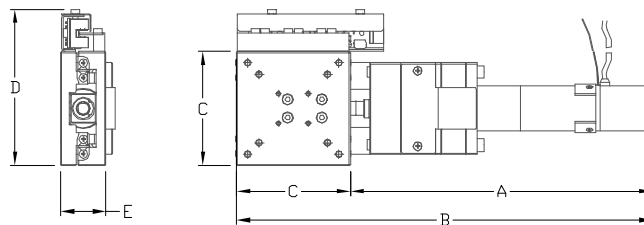

Galvano Optical Scanners LSA Series



- Galvanometric Laser Scanning Actuator
- High response frequency
 - High accuracy / repeatability
 - Continuous scanning or discrete pointing

•LSA Series Ratings

Model		Item	LSA-10A-30
Maximum Angular Runout		Degrees	±15
Rotor Moment of Inertia		g•cm ²	1.9
Torque Constant		N•m/A	0.008
Coil Resistance		Ω	0.28
Coil Inductance		mH	0.098
Sensor Linearity (At full scale)		%	±0.06
Sensor Angle Sensitivity		V/°	0.275
Offset Drift		μrad/°C	25
Scale Drift		%/°C	0.005
Repeatability (Excluding offset/scale drift)* 1		mrاد	±5
1°step Response Load Condition: (2g•cm ²)* 2		ms	0.5
Sensor Power Supply		V	5±5%-15±5%
Sensor Power Consumption	5V±5%	mA	90(Max)
	-15V±5%	mA	120(Max)
Weight		g	180

- 1: All angles are mechanical angles.
- 2: Values are at combination with a standard Harmonic Drive™r

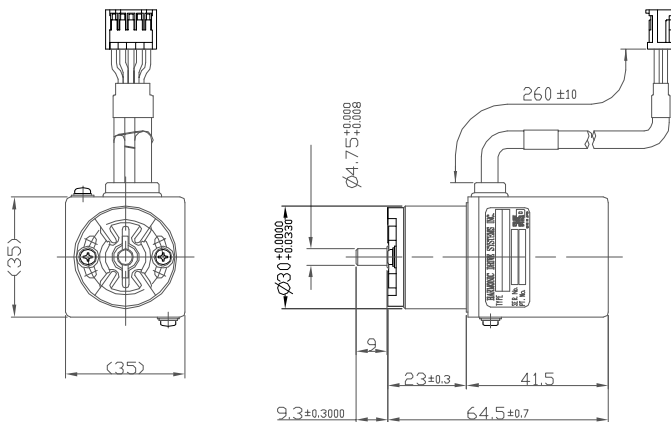

LSA-10A-30

Servo Drivers

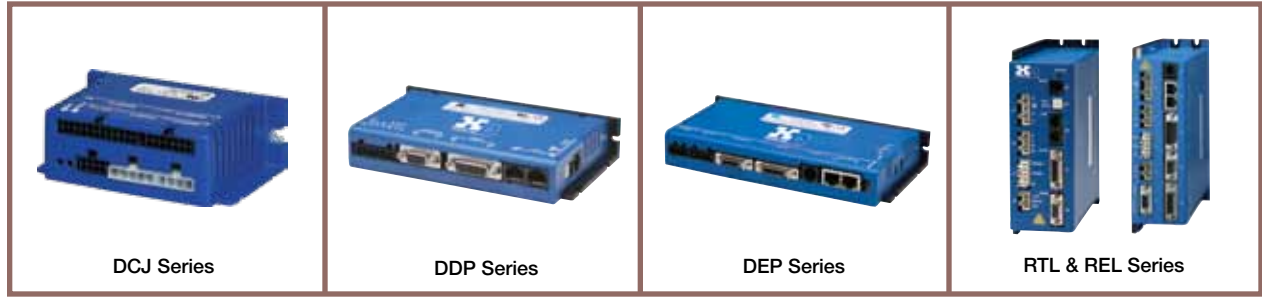

• Servo Driver Specifications

• DC Digital Servo Drive DCJ Series

MODEL	Vdc	Ic	Ip	Control Modes	Control Interface	Encoder
DCJ-055-09	20-55	3	9	Indexer, Point-to-Point, PVT Camming, Gearing, Position, Velocity, Torque	CANopen/DeviceNet ASCII and discrete I/O, Stepper commands ± 10V position/velocity/torque command PWM velocity/torque command Master encoder (Gearing/Camming)	14 Wire Standard Incremental Encoder Type
DCJ-055-18	20-55	6	18			
DCJ-090-03	20-90	1	3			
DCJ-090-09	20-90	3	9			
DCJ-090-12	20-91	6	12			

• DC Digital Servo Drive DDP Series

MODEL	Vdc	Ic	Ip	Control Modes	Control Interface	Encoder
DDP-090-09	90	3	9	Indexer, Point-to-Point, PVT Camming, Gearing, Position, Velocity, Torque	CANopen/DeviceNet ASCII and discrete I/O, Stepper commands ± 10V position/velocity/torque command PWM velocity/torque command Master encoder (Gearing/Camming)	14 Wire Standard Incremental Encoder Type
DDP-090-18	90	6	18			
DDP-090-36	90	12	36			
DDP-055-18	55	6	18			
DDP-180-09	180	3	9			
DDP-180-18	180	6	18			

• DC Digital Servo Drive DEP Series

MODEL	Vdc	Ic	Ip	Control Modes	Control Interface	Encoder
DEP-090-09	90	3	9	Indexer, Point-to-Point, PVT Camming, Gearing, Position, Velocity, Torque	CANopen over EtherCAT (CoE) ASCII and discrete I/O ± 10V position/velocity/torque command Master encoder (Gearing/Camming)	14 Wire Standard Incremental Encoder Type
DEP-090-18	90	6	18			
DEP-090-36	90	12	36			
DEP-055-18	55	6	18			
DEP-180-09	180	3	9			
DEP-180-18	180	6	18			4 Wire Serial Communication Incremental Encoder
DEP-090-09	90	3	9			
DEP-090-18	90	6	18			
DEP-090-36	90	12	36			
DEP-090-09	90	3	9			HD Absolute Encoder A Type
DEP-090-18	90	6	18			
DEP-090-36	90	12	36			

• AC Digital Servo Drive RTL Series

MODEL	Vdc	Ic	Ip	Control Modes	Control Interface	Encoder
RTL-230-18	100-240	6	18	Indexer, Point-to-Point, PVT Camming, Gearing, Position, Velocity, Torque	CANopen/DeviceNet ASCII and discrete I/O, Stepper commands ± 10V position/velocity/torque command PWM velocity/torque command Master encoder (Gearing/Camming)	14 Wire Standard Incremental Encoder Type
RTL-230-36	100-240	12	36			
RTL-230-40	100-240	20	40			

• AC Digital Servo Drive REL Series

MODEL	Vdc	Ic	Ip	Control Modes	Control Interface	Encoder
REL-230-18	100-240	6	18	Indexer, Point-to-Point, PVT Camming, Gearing, Position, Velocity, Torque	CANopen over EtherCAT (CoE) ASCII and discrete I/O, Stepper commands ± 10V position/velocity/torque command PWM velocity/torque command Master encoder (Gearing/Camming)	14 Wire Standard Incremental Encoder Type
REL-230-36	100-240	12	36			
REL-230-18	100-240	6	18			4 Wire Serial Communication Incremental Encoder
REL-230-36	100-240	12	36			
REL-230-18	100-240	6	18			
REL-230-36	100-240	12	36			HD Absolute Encoder S Type
REL-230-18	100-240	6	18			
REL-230-36	100-240	12	36			HD Absolute Encoder A Type
REL-230-40	100-240	20	40			

Combinations with Driver

•Combinations with Servo Drive and Actuator

•DC Digital Servo Drive DCJ Series

MODEL	Vdc	Ic	Ip	Supply Voltage	Combination Actuator
DCJ-055-09	20-55	3	9	DC24V	FHA-8C-30 / 50 / 100-US200-E, RSF-8B-30 / 50 / 100-F100-24B, RSF-5A-30 / 50 / 100-US050, RSF-3B-30 / 50 / 100-US020
DCJ-055-18	20-55	6	18		FHA-11C-30 / 50 / 100-US200-E
DCJ-090-03	20-90	1	3		-
DCJ-090-09	20-90	3	9		-
DCJ-090-12	20-91	6	12		-

•DC Digital Servo Drive DDP Series

MODEL	Vdc	Ic	Ip	Supply Voltage	Combination Actuator
DDP-090-09	90	3	9	DC24V	FHA-8C-30 / 50 / 100-US200-E, RSF-8B-30 / 50 / 100-F100-24B, RSF-5A-30 / 50 / 100-US050, RSF-3B-30 / 50 / 100-US020
DDP-090-18	90	6	18		FHA-11C-30 / 50 / 100-US200-E
DDP-090-36	90	12	36		FHA-14C-30 / 50 / 100-US200-E, FHA-17C50* / 100 / 160-US250-E-SP, RSF-14B-30 / 50 / 100-F100-24B, RSF-11B-30 / 50 / 100-F100-24B
DDP-055-18	55	6	18		-
DDP-180-09	180	3	9		-
DDP-180-18	180	6	18		-

•DC Digital Servo Drive DEP Series

MODEL	Vdc	Ic	Ip	Supply Voltage	Combination Actuator
DEP-090-09	90	3	9	DC24V	FHA-8C-30 / 50 / 100-US200-E, RSF-8B-30 / 50 / 100-F100-24B, RSF-5A-30 / 50 / 100-US050, RSF-3B-30 / 50 / 100-US020
DEP-090-18	90	6	18		FHA-11C-30 / 50 / 100-US200-E
DEP-090-36	90	12	36		FHA-14C-30 / 50 / 100-US200-E, FHA-17C50* / 100* / 160-US250-E-SP, RSF-14B-30 / 50 / 100-F100-24B, RSF-11B-30 / 50 / 100-F100-24B
DEP-090-09	90	3	9		FHA-8C-30 / 50 / 100-US200-E
DEP-90-18	90	6	18		FHA-11C-30 / 50 / 100-US200-E
DEP-90-36	90	12	36		FHA-14C-30 / 50 / 100-US200-E
DEP-090-09	90	3	9		FHA-8C-30 / 50 / 100-XXXX
DEP-90-18	90	6	18		FHA-11C-30 / 50 / 100-XXXX
DEP-90-36	90	12	36		FHA-14C-30 / 50 / 100-XXXX
DEP-055-18	55	6	18		-
DEP-180-09	180	3	9		-
DEP-180-18	180	6	18		-

•AC Digital Servo Drive RTL Series

MODEL	Vdc	Ic	Ip	Supply Voltage	Combination Actuator
RTL-230-18	100-240	6	18	AC100/200V	FHA-8C-30 / 50 / 100-US200, FHA-11C-30 / 50 / 100-US200, FHA-14C-30 / 50 / 100-US200
				AC100V	FHA-17C-50 / 100 / 160-US250-A, FHA-25C-100 / 160-US250-A, FHA-32C-160-US250-A
				AC200V	FHA-17C-50 / 100 / 160-US250, FHA-25C-100 / 160-US250, FHA-32C-160-US250, FHA-40C-100 / 160-US250
RTL-230-36	100-240	12	36	AC100V	FHA-25C-50-US250-A, FHA-32C-50 / 100-US250-A
				AC200V	FHA-40C-50-US250
RTL-230-40	100-240	20	40	AC200V	-

•AC Digital Servo Drive REL Series

MODEL	Vdc	Ic	Ip	Supply Voltage	Combination Actuator
REL-230-18	100-240	6	18	AC100/200V	FHA-8C-30 / 50 / 100-US200, FHA-11C-30 / 50 / 100-US200, FHA-14C-30 / 50 / 100-US200
				AC100V	FHA-17C-50 / 100 / 160-US250-A, FHA-25C-100 / 160-US250-A, FHA-32C-160-US250-A
				AC200V	FHA-17C-50 / 100 / 160-US250, FHA-25C-50 / 100 / 160-US250, FHA-32C-50 / 100 / 160-US250, FHA-40C-100 / 160-US250
REL-230-36	100-240	12	36	AC100V	FHA-25C-50-US250-A, FHA-32C-50 / 100-US250-A
				AC200V	FHA-40C-50-US250
REL-230-18	100-240	6	18	AC100/200V	FHA-8C-30 / 50 / 100-E200, FHA-11C-30 / 50 / 100-E200, FHA-14C-30 / 50 / 100-E200
				AC100V	FHA-17C-50 / 100 / 160-E250-A, FHA-25C-100 / 160-E250-A, FHA-32C-160-E250-A
				AC200V	FHA-17C-50 / 100 / 160-E250, FHA-25C-50 / 100 / 160-E250, FHA-32C-50 / 100 / 160-E250, FHA-40C-100 / 160-E250
REL-230-36	100-240	12	36	AC100V	FHA-25C-50-E250-A, FHA-32C-50 / 100-E250-A
				AC200V	FHA-40C-50-E250
REL-230-18	100-240	6	18	AC100V	FHA-17C-50 / 100 / 160-S248-A, FHA-25C-100 / 160-S248-A, FHA-32C-160-ES248-A
				AC200V	FHA-17C-50 / 100 / 160-S248, FHA-25C-50 / 100 / 160-S248, FHA-32C-50 / 100 / 160-ES248, FHA-40C-100 / 160-ES248
REL-230-36	100-240	12	36	AC100V	FHA-25C-50-S248-A, FHA-32C-50 / 100-ES248-A
				AC200V	FHA-40C-50-S248
REL-230-18	100-240	6	18	AC200V	SHA-25-51 / 81 / 101 / 121 / 161, SHA-32-161,
REL-230-36	100-240	12	36		SHA-32-51 / 81 / 101 / 121, SHA-40-121 / 161,
REL-230-40	100-240	20	40		SHA-40-51 / 81 / 101

Servo Drivers



• Servo Driver Specifications

• AC Servo Digital Drivers HA-720 Series

Model	HA-720-5-100
Rated Current	5A
Maximum Current	10A
Power Supply	AC100V ±10%
Encoder	Incremental Encoder: Phase A,B and Z Line driver output
Control System	Sine wave PWM control: 20kHz
Control Mode	Positioning control by pulse input or by command
Mass	1.4kg

• AC Servo Drivers HA-680 Series

Model	HA-680-4-24		HA-680-6-24	HA-680-4B-24	
Combined actuator	FHA-8C-xx-E200-CE	FHA-11C-xx-E200-CE	FHA-14C-xx-E200-CE	RSF-3A-xx-E020-C	RSF-5A-xx-E050 RSF-5A-xx-E050-B
Rated Current	1.8A	3.9A	6.0A	0.65A	1.2A
Maximum Current	3.4A	8.4A	16.5A	1.2A	2.3A
Power Supply	Main Circuit	DC24V(20-28V)			
	Control Circuit	DC24V(20-28V)			
Encoder	4-line specification, serial transmission method, line driver input			14-line specification line driver input	
Control System	Sinusoidal PWM control , switching frequency: 12.5 kHz				
Control Mode	Speed, position and torque control				
Mass	0.23kg				
Field Bus	Mechatrolink, CC-link, CAN Selectable				

Servo Drivers



• Servo Driver Specifications

• AC Servo Digital Drivers HA-655 Series

Model	Incremental	HA-655-1-100 HA-655-1B-100	HA-655-2-200 HA-655-2B-200	HA-655-4-200 HA-655-4B-200	HA-655-1-100 HA-655-1B-100	HA-655-2-100 HA-655-2B-100	HA-655-4-100 HA-655-4B-100
	Absolute	—	HA-655-2A-200	HA-655-4A-200	—	HA-655-2A-100	HA-655-4A-100
Rated Current	1.0A		2.4A	1.4A	1.0A	2.4A	4A
Maximum Current	3.2A		7.3A	18.0A	3.2A	7.3A	18.0A
Power Supply	Main Circuit	AC200~240V (Single phase/3 phases) +10~-15%			AC100~115V (Single phase) +10~-15%		
	Control Circuit	AC100~115V (Single phase) or AC200~240V (Single phase) +10~-15%			AC100~115V (Single phase) +10~-15%		
Control System	Sine wave PWM control						
Control Mode	Position control, speed control						
Weight	1.5kg		1.5kg	1.7kg	1.5kg	1.5kg	1.7kg

• AC Servo 1 Axis Controller Drivers HA-675 Series

Model	Incremental	HA-675-1-200	HA-675-2-200	HA-675-4-200	HA-675-1-100	HA-675-2-100	HA-675-4-100
	Absolute	—	HA-675-2A-200	HA-675-4A-200	—	HA-675-2A-100	HA-675-4A-100
Rated Current	1.0A		2.4A	4.0A	1.0A	2.4A	4.0A
Maximum Current	3.2A		7.3A	18.0A	3.2A	7.3A	18.0A
Power Supply	Main Circuit	AC200~240V (single phase/3 phases) +10~-15%			AC100~115V (Single phase) +10~-15%		
	Control Circuit	AC100~115V (Single phase) or AC200~240V (Single phase) +10~-15%			AC100~115V (Single phase) +10~-15%		
Control System	Sine wave PWM control						
Weight	1.5kg		1.5kg	1.7kg	1.5kg	1.5kg	1.7kg

• DC Servo Drivers HS-360 Series

Model	HS-360-1A	HS-360-1B	HS-360-1C	HS-360-1D	HS-360-3
Rated Current	1.0A	1.4A		3.2A	
Maximum Current	1.0A	2.6A	3.7A	4.2A	10A
Power Source Voltage	AC100V (Single Phase)±10%				
Encoder	Incremental Encoder (A, B and Z phase output), line driver system				
Control System	PWM control (control device: IPM), switching frequency: 12.5kHz				
Control Mode	Position control by pulse train output				
Weight	0.8kg	0.8kg	0.8kg	0.8kg	1.1kg

• Common Specification to Servo Driver Series

Environmental Conditions	Operating temperature: 0 to 50°C • Storage temperature: -20 to +85°C • Operating and storage humidity: 95% RH or lower (No condensation permitted). Vibration resistance: 4.9m/s ² (frequency: 0 to 55Hz) • Shock resistance: 98 m/S ² . No metal shaves and chips, no dust, no oil mist and no corrosive gas.
Structure/Mounting Direction	Totally enclosed, self cooling type/Wall-mount orientation

Combinations with Driver

•Combinations with Actuator and Servo Drive

Rotary Actuators

Type	Motor Type	Bus Voltage V	Encoder Type	Encoder Output Form	Servo Drive				
					HA-360	HA-655	HA-675	HA-680	US OEM
RSF-3B	Brushless DC	DC24	200 Line Incremental	8 wire open collector	x	x	x	x	o
				14 wire line driver (with relay cable option)	x	x	x	o	o
RSF-5A	Brushless DC	DC24	500 Line Incremental	8 wire open collector	x	x	x	x	o
				14 wire line driver (with relay cable option)	x	x	x	o	o
RSF-8B, 11B, 14B	Brushless DC	DC24	1000 Line Incremental	14 wire line driver	x	x	x	o	o
FHA-8C, 11C, 14C	Brushless DC	DC24	2000 Line Incremental	4 wire serial	x	o	o	x	x
				14 wire line driver	x	o	o	x	o
	Brushless DC	AC100 AC200	2000 Line Incremental	4 wire serial	x	o	o	x	x
				14 wire line driver	x	o	o	x	o
FHA-17C, 25C, 32C	Brushless DC	AC100 AC200	2,500 Line Incremental	4 wire serial	x	o	o	x	x
				14 wire line driver	x	0	0	x	0
			13bit Absolute	4 wire serial	x	o	o	x	x
FHA-40C	Brushless DC	AC200	2,500 Line Incremental	4 wire serial	x	o	o	x	x
				14 wire line driver	x	o	o	x	o
			13bit Absolute	4 wire serial	x	0	0	x	x
RH-5A	Brush DC	DC12	200, 360, or 500 Line Incremental	8 wire open collector	o	x	x	x	o
				14 wire line driver	o	x	x	x	o
RH-8D, 11D, 14D	Brush DC	DC24	200, 360, 500 or 1000 Line Incremental	8 wire open collector	o	x	x	x	o
				14 wire line driver	o	x	x	x	o

Galvano Optical Scanner

Series	Model No.	Servo Drive
LSA	All models	PSM-130

Linear Actuators

Series	Model No.	Servo Drive
LA*	30	HS-360-1A-100
	32	HS-360-1A-100
LAH*	46	HS-360-1A-100
	80	
LBC	25	HA-655-2B-200
		HA-675-2B-200
LNP*		HS-360-1A-100

• RH,LA,LAH,LNP series actuators will require servo drive encoder when used in conjunction with a HS-360 driver.

Cup Type High Torque CSG Series

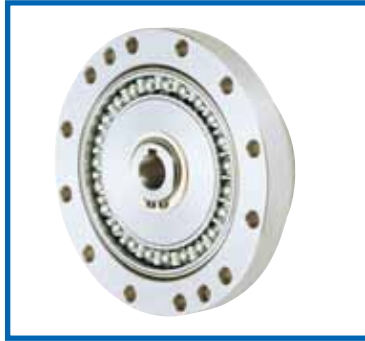

- Compact and simple design
- High torque capacity
- High torsional stiffness
- Zero backlash
- High positioning accuracy
- Housed unit type is available (see p. 28)
- 30% higher torque than a CSF unit

L_{10} Life: 10,000 h

Comparison of Features. High Torque Harmonic Drive™ CSG Series vs. CSF Series

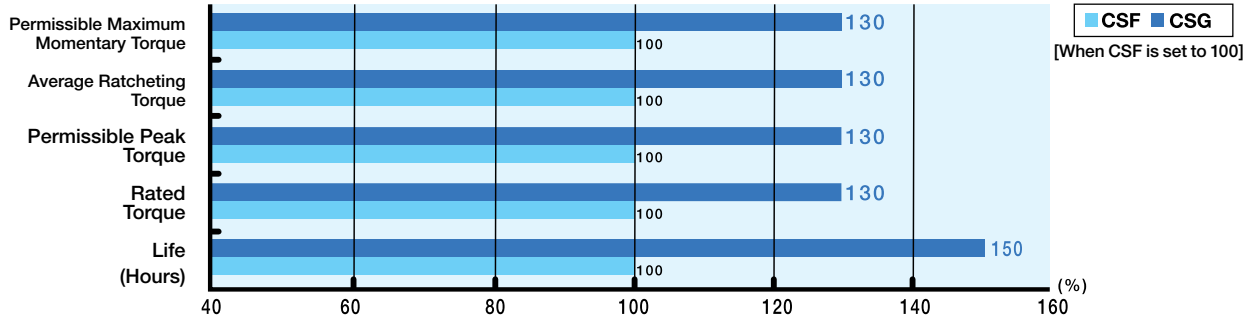

•CSG Series Ratings

Item	Reduction Ratio	Rated Torque at 2000rpm		Limit for Repeated Peak Torque		Permissible Maximum Momentary Torque	
		N•m	In.lb	N•m	In.lb	N•m	In.lb
14	50	7.0	62	23	204	46	407
	80	10	89	30	266	61	540
	100	10	89	36	319	70	620
17	50	21	186	44	389	91	805
	80	29	257	56	496	113	1000
	100	31	274	70	620	143	1266
20	50	33	292	73	646	127	1124
	80	44	389	96	850	165	1460
	100	52	460	107	947	191	1690
25	50	51	451	127	1124	242	2142
	80	82	726	178	1575	332	2938
	100	87	770	204	1805	369	3266
32	50	99	876	281	2487	497	4398
	80	153	1354	395	3496	738	6531
	100	178	1575	433	3832	841	7443

Item	Reduction Ratio	Rated Torque at 2000rpm		Limit for Repeated Peak Torque		Permissible Maximum Momentary Torque	
		N•m	In.lb	N•m	In.lb	N•m	In.lb
40	50	178	1575	523	4629	892	7894
	80	268	2372	675	5974	1270	11240
	100	345	3053	738	6531	1400	12390
	120	382	3381	802	7098	1530	13541
45	50	229	2027	650	5753	1235	10930
	80	407	3602	918	8124	1651	14611
	100	459	4062	982	8691	2041	18063
	120	523	4629	1070	9470	2288	20249
50	50	523	4629	1147	10151	2483	21975
	80	484	4283	1223	10824	2418	21399
	100	611	5407	1274	11275	2678	23700
	120	688	6089	1404	12425	2678	23700
58	50	688	6089	1534	13576	3185	28187
	80	714	6319	1924	17027	3185	28187
	100	905	8009	2067	18293	4134	36586
	120	969	8576	2236	19789	4329	38312
65	50	969	8576	2392	21169	4459	39462
	80	969	8576	2743	24276	4836	42799
	100	1236	10939	2990	26462	6175	54649
	120	1236	10939	3263	28878	6175	54649

Unit: mm

Model No	14	17	20	25	32	40	45	50	58	65
Symbol										
∅ A	50	60	70	85	110	135	155	170	195	215
B	28.5	32.5	33.5	37	44	53	58.5	64	75.5	83

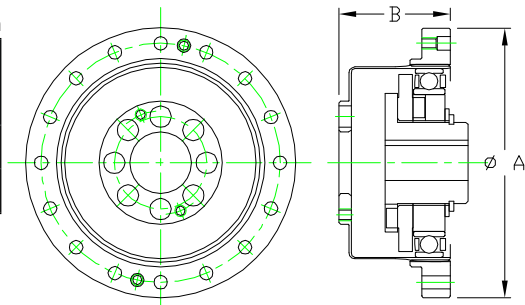

Drawings (DXF) can be downloaded from our home page. URL: <http://www.HarmonicDrive.net>

Cup Type - Super Flat Type
CSD Series



- Superior axial compactness
- Hollow through bore
- Excellent Repeatability
- Also available with extra large through bore

L₁₀ Life: 7,000 h

•CSD Series Ratings

Item Model No.	Reduction Ratio	Rated Torque at 2000 rpm		Limit for Repeated Peak Torque		Permissible Maximum Monetary Torque	
		N•m	In.lb	N•m	In.lb	N•m	In.lb
14	50	3.7	33	12	106	24	212
	100	5.4	48	19	168	31	274
17	50	11	97	23	204	48	425
	100	16	142	37	327	55	487
20	50	17	150	39	345	69	611
	100	28	248	57	504	76	673
	160	28	248	64	566	76	673
25	50	27	239	69	611	127	1124
	100	47	416	110	974	152	1345
	160	47	416	123	1089	152	1345
32	50	53	469	151	1336	268	2372
	100	96	850	233	2062	359	3177
	160	96	850	261	2310	359	3177
40	50	96	850	281	2487	480	4248
	100	185	1637	398	3522	694	6142
	160	206	1823	453	4009	694	6142
50	50	172	1522	500	4425	1000	8850
	100	329	2912	686	6071	1440	12744
	160	370	3275	823	7284	1577	13956

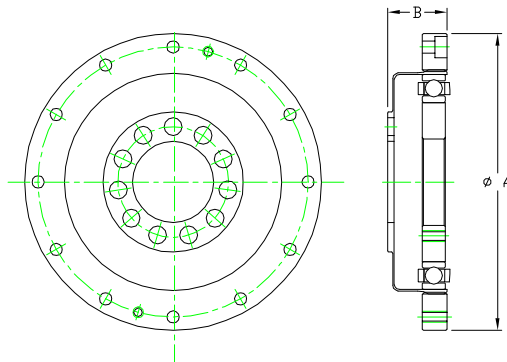

Unit: mm

No	14	17	20	25	32	40	50
Symbol							
ø A h7	50	60	70	85	110	135	170
B	11	12.5	14	17	22	27	33

Cup Type CSF Series

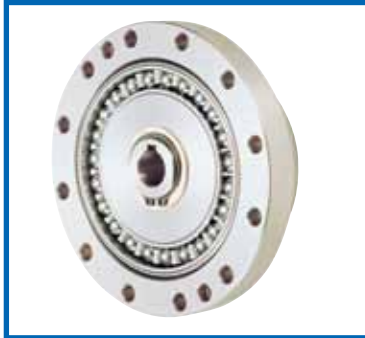

- Compact design
- High torque capacity
- High torsional stiffness
- Zero backlash
- High positioning accuracy
- Housed configuration is available (see p. 29)

L_{10} Life: 7,000 h

•CSF Series Ratings

Item Model No.	Reduction Ratio	Rated Torque at 200rpm		Limit for Repeated Peak Torque		Permissible Maximum Momentary Torque	
		N•m	In.lb	N•m	In.lb	N•m	In.lb
8	30	0.9	8	1.8	16	3.3	29
	50	1.8	16	3.3	29	6.6	58
	100	2.4	21	4.8	42	9.0	80
11	30	2.2	19	4.5	40	8.5	75
	50	3.5	31	8.3	73	17	150
	100	5.0	44	11	97	25	221
14	30	4.0	35	9.0	80	17	150
	50	5.4	48	18	159	35	310
	80	7.8	69	23	204	47	416
17	30	8.8	78	16	142	30	266
	50	16	142	34	301	70	620
	80	22	195	43	381	87	770
20	30	24	212	54	478	108	956
	50	25	221	56	496	98	867
	80	34	301	74	655	127	1124
25	30	15	133	27	239	50	443
	50	25	221	56	496	98	867
	80	34	301	74	655	127	1124
32	30	54	478	100	885	200	1770
	50	76	673	216	1912	382	3381
	80	118	1044	304	2690	568	5027
40	30	137	1212	333	2947	647	5726
	50	137	1212	353	3124	686	6071
	80	137	1212	372	3292	686	6071
45	30	137	1212	402	3558	686	6071
	50	206	1823	519	4593	980	8673
	80	265	2345	568	5027	1080	9558
50	30	294	2602	617	5460	1180	10443
	50	294	2602	647	5726	1180	10443

Item Model No.	Reduction Ratio	Rated Torque at 200rpm		Limit for Repeated Peak Torque		Permissible Maximum Momentary Torque	
		N•m	In.lb	N•m	In.lb	N•m	In.lb
45	50	176	1558	500	4425	950	8408
	80	313	2770	706	6248	1270	11240
	100	353	3124	755	6682	1570	13895
	120	402	3558	823	7284	1760	15576
50	160	402	3558	882	7806	1910	16904
	50	245	2168	715	6328	1430	12656
	80	372	3292	941	8328	1860	16461
	100	470	4160	980	8673	2060	18231
58	120	529	4682	1080	9558	2060	18231
	160	529	4682	1180	10443	2450	21683
	50	353	3124	1020	9027	1960	17346
	80	549	4859	1480	13098	2450	21683
65	100	696	6160	1590	14072	3180	28143
	120	745	6593	1720	15222	3330	29471
	160	745	6593	1840	16284	3430	30356
	50	490	4337	1420	12567	2830	25046
80	80	745	6593	2110	18674	3720	32922
	100	951	8416	2300	20355	4750	42038
	120	951	8416	2510	22214	4750	42038
	160	951	8416	2630	23276	4750	42038
90	50	872	7717	2440	21594	4870	43100
	80	1320	11682	3430	30356	6590	58322
	100	1700	15045	4220	37347	7910	70004
	120	1990	17612	4590	40622	7910	70004
100	160	1990	17612	4910	43454	7910	70004
	50	1180	10443	3530	31241	6660	58941
	80	1550	13718	3990	35312	7250	64163
	100	2270	20090	5680	50268	9020	79827
100	120	2570	22745	6160	54516	9800	86730
	160	2700	23895	6840	60534	11300	100005
	50	1580	13983	4450	39383	8900	78765
	80	2380	21063	6060	53631	11600	102660
100	100	2940	26019	7350	65048	14100	124785
	120	3180	28143	7960	70446	15300	135405
	160	3550	31418	9180	81243	15500	137175

Unit: mm

Model No	8	11	14	17	20	25	32	40
Symbol								
øA	30	10	50	60	70	85	110	135
B	22.1	25.8	28.5	32.5	33.5	37	44	53
Model No	45	50	58	65	80	90	100	
Symbol								
øA	155	170	195	215	265	300	330	
B	58.5	64	75.5	83	101	112.5	125	

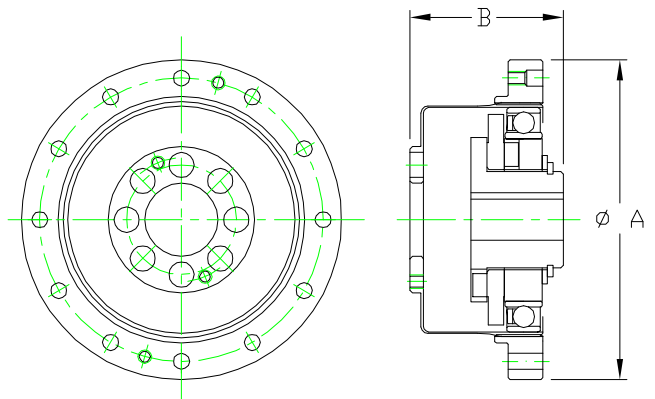

Drawings (DXF) can be downloaded from our home page. URL: <http://www.HarmonicDrive.net>

Silk Hat Type - High-Torque SHG Series



- Hollow bore units available
- Zero backlash
- Excellent positioning accuracy
- Compact and simple design
- High torque capacity
- High torsional stiffness
- 30% higher torque rating than SHF series

L₁₀ Life: 10,000h

•Comparison of Features. High Torque Harmonic Drive™ High Torque SHG Series

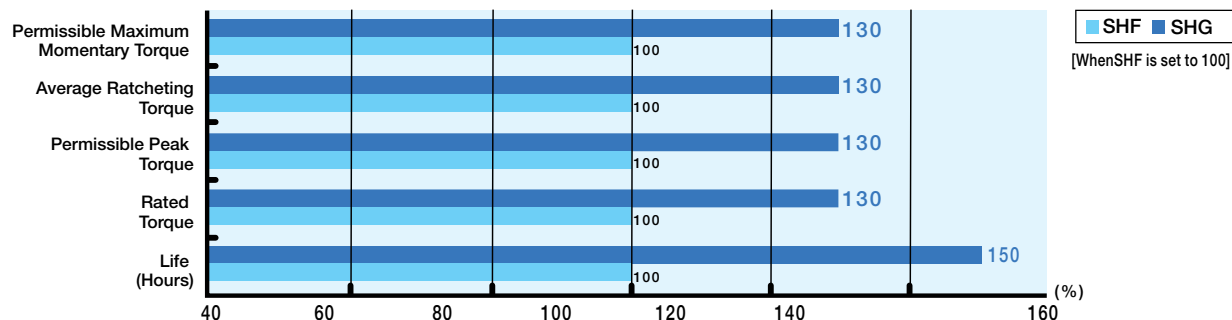

•SHG Series Ratings

Item Model No.	Reduction Ratio	Rated Torque at 2000rpm		Permissible Peak Torque		Permissible Maximum Momentary Torque	
		N•m	In.lb	N•m	In.lb	N•m	In.lb
14	50	7.0	62	23	204	46	407
	80	10	89	30	266	61	540
	100	10	89	36	319	70	620
17	50	21	186	44	389	91	805
	80	29	257	56	496	113	1000
	100	31	274	70	620	143	1266
20	50	33	292	73	646	127	1124
	80	44	389	96	850	165	1460
	100	52	460	107	947	191	1690
25	50	51	451	127	1124	242	2142
	80	82	726	178	1575	332	2938
	100	87	770	204	1805	369	3266
32	50	99	876	281	2487	497	4398
	80	153	1354	395	3496	738	6531
	100	178	1575	433	3832	841	7443

Item Model No.	Reduction Ratio	Rated Torque at 2000rpm		Permissible Peak Torque		Permissible Maximum Momentary Torque	
		N•m	In.lb	N•m	In.lb	N•m	In.lb
40	50	178	1575	523	4629	892	7894
	80	268	2372	675	5974	1270	11240
	100	345	3053	738	6531	1400	12390
	120	382	3381	802	7098	1530	13541
45	50	229	2027	650	5753	1235	10930
	80	407	3602	918	8124	1651	14611
	100	459	4062	982	8691	2041	18063
	120	523	4629	1070	9470	2288	20249
50	50	229	2027	650	5753	1235	10930
	80	484	4283	1223	10824	2418	21399
	100	611	5407	1274	11275	2678	23700
	120	688	6089	1404	12425	2678	23700
58	50	229	2027	650	5753	1235	10930
	80	714	6319	1924	17027	3185	28187
	100	905	8009	2067	18293	4134	36586
	120	969	8576	2236	19789	4329	38312
65	50	229	2027	650	5753	1235	10930
	80	969	8576	2743	24276	4836	42799
	100	1236	10939	2990	26462	6175	54649
	120	1236	10939	3263	28878	6175	54649

Unit: mm

Model No	14	17	20	25	32	40	45	50	58	65
Symbol										
∅A	50	60	70	85	110	135	155	170	195	215
B	28.5	32.5	33.5	37	44	53	58.5	64	75.5	83

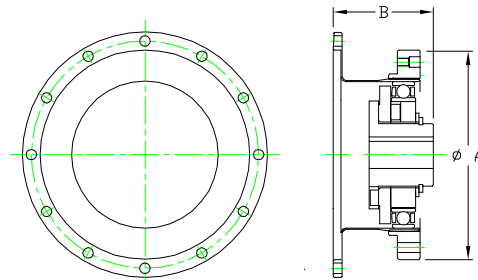

Drawings (DXF) can be downloaded from our home page. URL: <http://www.HarmonicDrive.net>



- Hollow bore units available
- Compact and simple design
- Zero backlash
- High torque capacity
- High positioning accuracy
- High torsional stiffness
- Housed in is available (see p. 31))

L₁₀ Life: 7,000 h

•SHF Series Ratings

Item Model	Reduction Ratio	Rated Torque at 2000rpm		Permissible Peak Torque		Permissible Maximum Momentary Torque		Item Model	Reduction Ratio	Rated Torque at 2000rpm		Limit for Repeated Peak Torque		Permissible Maximum Momentary Torque	
		N•m	In.lb	N•m	In.lb	N•m	In.lb			N•m	In.lb	N•m	In.lb	N•m	In.lb
14	30	4.0	35	9.0	80	17	150	40	50	137	1212	402	3558	686	6071
	50	5.4	48	18	159	35	310		80	206	1823	519	4593	980	8673
	80	7.8	69	23	204	47	416		100	265	2345	568	5027	1080	9558
	100	7.8	69	28	248	54	478		120	294	2602	617	5460	1180	10443
17	30	8.8	78	16	142	30	266		160	294	2602	647	5726	1180	10443
	50	16	142	34	301	70	620		50	176	1558	500	4425	950	8408
	80	22	195	43	381	87	770	80	313	2770	706	6248	1270	11240	
	100	24	212	54	478	110	974	100	353	3124	755	6682	1570	13895	
20	120	24	212	54	478	86	761	120	402	3558	823	7284	1760	15576	
	30	15	133	27	239	50	443	160	402	3558	882	7806	1910	16904	
	50	25	221	56	496	98	867	50	245	2168	715	6328	1430	12656	
	80	34	301	74	655	127	1124	80	372	3292	941	8328	1860	16461	
	100	40	354	82	726	147	1301	100	470	4160	980	8673	2060	18231	
	120	40	354	87	770	147	1301	120	529	4682	1080	9558	2060	18231	
25	160	40	354	92	814	147	1301	160	529	4682	1180	10443	2450	21683	
	30	27	239	50	443	95	841	50	353	3124	020	9027	1960	17346	
	50	39	345	98	867	86	1646	80	549	4859	1480	13098	2450	21683	
	80	63	558	137	1212	255	2257	100	696	6160	1590	14072	3180	28143	
	100	67	593	157	1389	284	2513	120	745	6593	1720	15222	3330	29471	
	120	67	593	167	1478	304	2690	160	745	6593	1840	16284	3430	30356	
32	160	67	593	176	1558	314	2779	30	54	478	100	885	200	1770	
	30	54	478	100	885	200	1770	50	76	673	216	1912	382	3381	
	50	76	673	216	1912	382	3381	80	118	1044	230	2036	568	5027	
	80	118	1044	230	2036	568	5027	100	137	1212	333	2947	647	5726	
	120	137	1212	353	3124	686	6071	120	137	1212	353	3124	686	6071	
	160	137	1212	372	3292	686	6071	160	137	1212	372	3292	686	6071	

Unit: mm

Size	14	17	20	25	32	40	45	50	58
Symbol									
øA	50	60	70	85	110	135	155	170	195
B	28.5	32.5	33.5	37	44	53	58.5	64	75.5

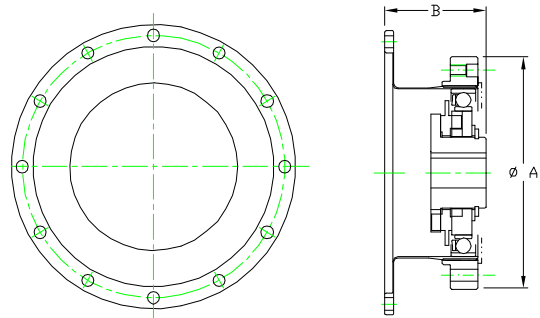

High Torque Type CSG Series

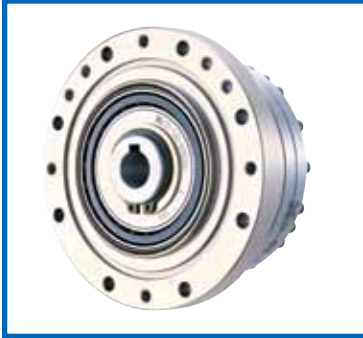

- High torque capacity
- High torsional stiffness
- Compact and simple design
- Zero backlash
- High positioning accuracy
- 30% higher torque than a CSF unit

L_{10} Life: 10,000h

•CSG Series Ratings

Item Model No.	Reduction Ratio	Rated Torque at 2000rpm		Limit for Repeated Peak Torque		Permissible Maximum Momentary Torque	
		N•m	In.lb	N•m	In.lb	N•m	In.lb
14	50	7.0	62	23	204	46	407
	80	10	89	30	266	61	540
	100	10	89	36	319	70	620
17	50	21	186	44	389	91	805
	80	29	257	56	496	113	1000
	100	31	274	70	620	143	1266
20	50	33	292	73	646	127	1124
	80	44	389	96	850	165	1460
	100	52	460	107	947	191	1690
25	50	51	451	127	1124	242	2142
	80	82	726	178	1575	332	2938
	100	87	770	204	1805	369	3266
32	50	99	876	281	2487	497	4398
	80	153	1354	395	3496	738	6531
	100	178	1575	433	3832	841	7443
40	50	178	1575	484	4283	892	7894
	80	268	2372	675	5974	1270	11240
	100	345	3053	738	6531	1400	12390
45	50	229	2027	650	5753	1235	10930
	80	407	3602	918	8124	1651	14611
	100	459	4062	982	8691	2041	18063
50	50	523	4629	1070	9470	2288	20249
	80	611	5407	1274	11275	2678	23700
	100	688	6089	1404	12425	2678	23700
58	50	688	6089	1534	13576	3185	28187
	80	714	6319	1924	17027	3185	28187
	100	905	8009	2067	18293	4134	36586
65	50	969	8576	2236	19789	4329	38312
	80	969	8576	2392	21169	4459	39462
	100	969	8576	2743	24276	4836	42799
65	50	1236	10939	2990	26462	6175	54649
	80	1236	10939	3263	28878	6175	54649
	100	1236	10939	3419	30258	6175	54649

Item Model No.	Reduction Ratio	Rated Torque at 2000rpm		Limit for Repeated Peak Torque		Permissible Maximum Momentary Torque	
		N•m	In.lb	N•m	In.lb	N•m	In.lb
40	50	178	1575	523	4629	892	7894
	80	268	2372	675	5974	1270	11240
	100	345	3053	738	6531	1400	12390
	120	382	3381	802	7098	1530	13541
45	50	229	2027	650	5753	1235	10930
	80	407	3602	918	8124	1651	14611
	100	459	4062	982	8691	2041	18063
	120	523	4629	1070	9470	2288	20249
50	50	523	4629	1147	10151	2483	21975
	80	484	4283	1223	10824	2418	21399
	100	611	5407	1274	11275	2678	23700
	120	688	6089	1404	12425	2678	23700
58	50	688	6089	1534	13576	3185	28187
	80	714	6319	1924	17027	3185	28187
	100	905	8009	2067	18293	4134	36586
	120	969	8576	2236	19789	4329	38312
65	50	969	8576	2392	21169	4459	39462
	80	969	8576	2743	24276	4836	42799
	100	1236	10939	2990	26462	6175	54649
	120	1236	10939	3263	28878	6175	54649

•Cross Roller Bearing Specification

Item Model No.	Basic Rated Load				Permissible Moment Load Mc		Moment Stiffness Km	
	Basic Dynamic Rated Load C		Basic Static Rated Load Co		N•m	In.lb	x 10 ⁴ N•m /rad	In.lb/arc-min
	x 10 ³ N	lb	x 10 ³ N	lb				
14	47	1057	60.7	1365	41	363	4.38	113
17	52.9	1189	75.5	1697	64	566	7.75	200
20	57.8	1299	90.0	2023	91	805	12.8	330
25	96.0	2158	151	3394	156	1381	24.2	623
32	150	3372	250	5620	313	2770	53.9	1388
40	213	4788	365	8205	450	3983	91.0	2343
45	230	5170	426	9576	686	6071	141	3631
50	348	7823	602	13533	759	6717	171	4403
58	518	11645	904	20322	1180	10443	283	7287
65	556	12499	1030	23154	1860	16461	404	10403

- "Basic dynamic rated load" is a constant stationary radial load that achieves a basic dynamic rated life of the bearing of one million revolutions.
- "Basic static rated load" is a static load that achieves a contact stress of a constant level (408kN/mm²) at the center of a contact zone between the rolling element receiving a maximum load and track.
- The moment stiffnesses are mean values.

Unit: mm

Model No.	14	17	20	25	32	40	45	50	58	65
Symbol										
øA	73	79	93	107	138	160	180	190	226	260
B	41	45	45.5	52	62	72.5	79.5	90	104.5	115

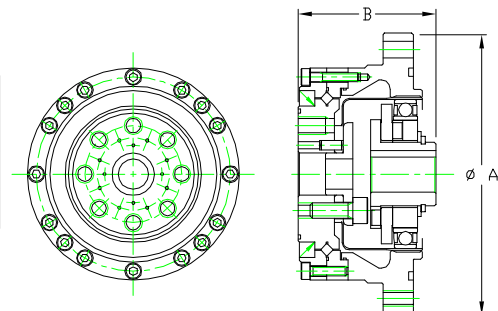

Drawings (DXF) can be downloaded from our home page. URL: <http://www.HarmonicDrive.net>

CSF Series

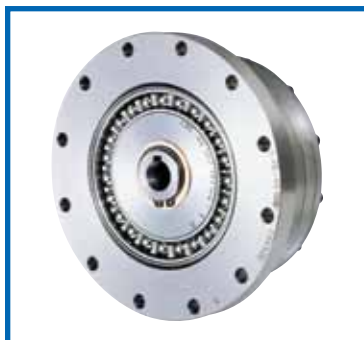

- Compact and simple design
- High torque capacity
- High torsional stiffness
- Zero backlash
- High positioning accuracy

L_{10} Life: 7,000 h

•CSF Series Ratings

Item Model No.	Reduction Ratio	Rated Torque at 2000rpm		Limit for Repeated Peak Torque		Permissible Maximum Momentary Torque	
		N•m	In.lb	N•m	In.lb	N•m	In.lb
14	30	4.0	35	9.0	80	17	150
	50	5.4	48	18	159	35	310
	80	7.8	69	23	204	47	416
17	100	7.8	69	28	248	54	478
	30	8.8	78	6	142	30	266
	50	16	142	34	301	70	620
	80	22	195	43	381	87	770
20	100	24	212	54	478	108	974
	120	24	212	54	478	86	761
	30	15	133	27	239	50	443
	50	25	221	56	496	98	867
25	80	34	301	74	655	127	1124
	100	40	354	82	726	147	1301
	120	40	354	87	770	147	1301
	160	40	354	92	814	147	1301
32	30	27	239	50	443	95	841
	50	39	345	98	867	186	1646
	80	63	558	137	1212	255	2257
	100	67	593	157	1389	284	2513
	120	67	593	167	1478	304	2690
40	160	67	593	176	1558	314	2779
	30	54	478	100	885	200	1770
	50	76	673	216	1912	382	3381
	80	118	1044	304	2036	568	5027
	100	137	1212	333	2947	647	5726
45	120	137	1212	353	3124	686	6071
	160	137	1212	372	3292	686	6071

Item Model No.	Reduction Ratio	Rated Torque at 2000rpm		Limit for Repeated Peak Torque		Permissible Maximum Momentary Torque	
		N•m	In.lb	N•m	In.lb	N•m	In.lbs
14	50	137	1212	402	3558	686	6071
	80	206	1823	519	4593	980	8673
	100	265	2345	568	5027	1080	9558
	120	294	2602	617	5460	1180	10443
	160	294	2602	647	5726	1180	10443
17	50	176	1558	500	4425	950	8408
	80	313	2770	706	6248	1270	11240
	100	353	3124	755	6682	1570	13895
	120	402	3558	823	7284	1760	15576
	160	402	3558	882	7806	1910	16904
20	50	245	2168	715	6328	1430	12656
	80	372	3292	941	8328	1860	16461
	100	470	4160	980	8673	2060	18231
	120	529	4682	1080	9558	2060	18231
	160	529	4682	1180	10443	2450	21683
25	50	353	3124	1020	9027	1960	17346
	80	549	4859	1480	13098	2450	21683
	100	686	6160	1590	14072	3180	28143
	120	745	6593	1720	15222	3330	29471
	160	745	6593	1840	16284	3430	30356
32	50	490	4337	1420	12567	2830	25046
	80	745	6593	2110	18674	3720	32922
	100	951	8416	2300	20355	4750	42038
	120	951	8416	2510	22214	4750	42038
	160	951	8416	2630	23276	4750	42038

•Cross Roller Bearing Specification

Item Model No.	Basic Rated Load				Permissible Moment Load Mc		Moment Stiffness Km	
	Basic Dynamic Rated Load C		Basic Static Rated Load Co		N•m	In.lb	x 10 ³ N•m /rad	In.lb/arc-min
	x 10 ³ N	lb	x 10 ³ N	lb				
14	47	1057	60.7	1365	41	363	4.38	113
17	52.9	1189	75.5	1697	91	566	7.75	200
20	57.8	1299	90.0	2023	91	805	12.8	330
25	96.0	2158	151	3394	156	1381	24.2	623
32	150	3372	250	5620	313	2770	53.9	1388
40	213	4788	365	8205	450	3983	91.0	2343
45	230	5170	426	9576	686	6071	141	3631
50	348	7823	602	13533	759	6717	171	4403
58	518	11645	904	20322	1180	10443	283	7287
65	556	12499	1030	23154	1860	16461	404	10403

- "Basic dynamic rated load" is a constant stationary radial load that achieves a basic dynamic rated life of the bearing of one million revolutions.
- "Basic static rated load" is a static load that achieves a contact stress of a constant level (408kN/mm²) at the center of a contact zone between the rolling element receiving a maximum load and track.
- The moment stiffnesses are mean values.

Model No. Symbol	Unit: mm									
	14	17	20	25	32	40	45	50	58	65
øA	73	79	93	107	138	160	180	190	226	260
B	41	45	45.5	52	62	72.5	79.5	90	104.5	115

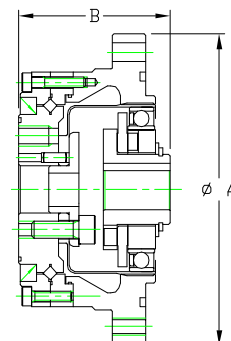
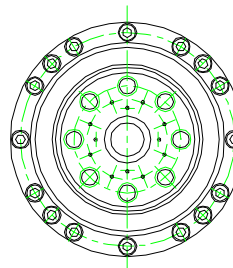

Drawings (DXF) can be downloaded from our home page. URL: <http://www.HarmonicDrive.net>



Unit High-torque Hollow Shaft / Input Shaft Types
Simple Unit/High-torque Flat, Hollow, High-torque Flat Types

SHG Series



- Large hollow thru bore
- Flat profile
- Zero backlash
- High positioning accuracy
- Compact and simple design
- High torque capacity
- High torsional stiffness
- Shaft input units available
- 30% increased torque compared to SHF Units

L₁₀ Life: 10,000 h

•SHG Series Ratings

Item Model No.	Reduction Ratio	Rated Torque at 2000rpm		Limit for Repeated Peak Torque		Permissible Maximum Momentary Torque	
		N•m	In.lb	N•m	In.lb	N•m	In.lb
14	50	7.0	62	23	204	46	407
	80	10	89	30	266	61	540
	100	10	89	36	319	70	620
17	50	21	186	44	389	91	805
	80	29	257	56	496	113	1000
	100	31	274	70	620	143	1266
20	120	31	274	70	620	112	991
	50	33	292	73	646	127	1124
	80	44	389	96	850	165	1460
	100	52	460	107	947	191	1690
25	120	52	460	113	1000	191	1690
	160	52	460	120	1062	191	1690
	50	51	451	127	1124	242	2142
	80	82	726	178	1575	332	2938
32	100	87	770	204	1805	369	3266
	120	87	770	217	1920	395	3496
	160	87	770	229	2027	408	3611
	50	99	876	281	2487	497	4398
40	80	153	1354	395	3496	738	6531
	100	178	1575	433	3832	841	7443
	120	178	1575	459	4062	892	7894
	160	178	1575	484	4283	892	7894

Item Model No.	Reduction Ratio	Rated Torque at 2000rpm		Limit for Repeated Peak Torque		Permissible Maximum Momentary Torque	
		N•m	In.lb	N•m	In.lb	N•m	In.lb
40	50	178	1575	523	4629	892	7894
	80	268	2372	675	5974	1270	11240
	100	345	3053	738	6531	1400	12390
	120	382	3381	802	7098	1530	13541
45	160	382	3381	841	7443	1530	13541
	50	229	2027	650	5753	1235	10930
	80	407	3602	918	8124	1651	14611
	100	459	4062	982	8691	2041	18063
50	120	523	4629	1070	9470	2288	20249
	160	523	4629	1147	10151	2483	21975
	80	484	4283	1223	10824	2418	21399
	100	611	5407	1274	11275	2678	23700
58	120	688	6089	1404	12425	2678	23700
	160	688	6089	1534	13576	3185	28187
	80	714	6319	1924	17027	3185	28187
	100	905	8009	2067	18293	4134	36586
65	120	969	8576	2236	19789	4329	38312
	160	969	8576	2392	21169	4459	39462
	80	969	8576	2743	24276	4836	42799
	100	1236	10939	2990	26462	6175	54649
65	120	1236	10939	3263	28878	6175	54649
	160	1236	10939	3419	30258	6175	54649

•Cross Roller Bearing Specification

Item Model No.	Basic Rated Load				Permissible Moment Load Mc		Moment Stiffness Km	
	Basic Dynamic Rated Load C		Basic Static Rated Load Co					
	x 10 ² N	lb	x 10 ² N	lb	N•m	In.lb	x 10 ⁴ N•m / rad	In.lb/arc-min
14	58	1304	86	1933	74	655	8.5	219
17	104	2338	163	3664	124	1097	15.1	389
20	146	3282	220	4946	187	1655	25.2	649
25	218	4901	358	8048	258	2283	39.2	1009
32	382	8587	654	14702	580	5133	100	2575
40	433	9734	816	18344	849	7514	179	4609
45	776	17444	1350	30348	1127	9974	257	6618
50	816	18344	1490	33495	1487	13160	351	9038
58	874	19648	1710	38441	2180	19293	531	13673
65	1300	29224	2230	50130	2740	24249	741	19081

• "Basic dynamic rated load" is a constant stationary radial load that achieves a basic dynamic rated life of the bearing of one million revolutions.
 "Basic static rated load" is a static load that achieves a contact stress of a constant level (408kN/mm²) at the center of a contact zone between the rolling element receiving a maximum load and track.

Unit: mm

Model No.	14	17	20	25	32	40	45	50	58	65
Symbol										
øA	54	64	75	90	115	140	160	175	201	221
B	52.5	56.5	51.5	55.5	65.5	79	85	93	106	128

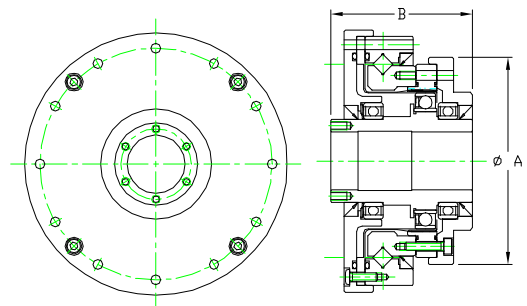

Drawings (DXF) can be downloaded from our home page. URL: <http://www.HarmonicDrive.net>

SHF Series Unit/Standard Type

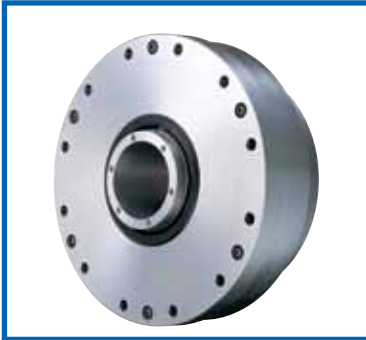

- Large hollow thru bore
- Flat profile
- Zero backlash
- High positioning accuracy
- Compact and simple design
- High torque capacity
- High torsional stiffness
- Shaft input units available

L_{10} Life: 7,000 h

•SHF Series Ratings

Item Model No.	Reduction Ratio	Rated Torque at 2000rpm		Limit for Repeated Peak Torque		Permissible Maximum Momentary Torque	
		N•m	In.lb	N•m	In.lb	N•m	In.lb
14	30	4.0	35	9.0	80	17	150
	50	5.4	48	18	159	35	310
	80	7.8	69	23	204	47	416
	100	7.8	69	28	248	54	478
17	30	8.8	78	6	142	30	266
	50	16	142	34	301	70	620
	80	22	195	43	381	87	770
	100	24	212	54	478	110	974
20	30	15	133	27	239	50	443
	50	25	221	56	496	98	867
	80	34	301	74	655	127	1124
	100	40	354	82	726	147	1301
25	30	27	239	50	443	95	841
	50	39	345	98	867	186	1646
	80	63	558	137	1212	255	2257
	100	67	593	157	1389	284	2513
32	30	54	478	100	885	200	1770
	50	76	673	216	1912	382	3381
	80	118	1044	230	2036	568	5027
	100	137	1212	333	2947	647	5726
40	30	27	239	50	443	95	841
	50	39	345	98	867	186	1646
	80	63	558	137	1212	255	2257
	100	67	593	157	1389	284	2513
45	30	27	239	50	443	95	841
	50	39	345	98	867	186	1646
	80	63	558	137	1212	255	2257
	100	67	593	157	1389	284	2513
50	30	27	239	50	443	95	841
	50	39	345	98	867	186	1646
	80	63	558	137	1212	255	2257
	100	67	593	157	1389	284	2513
58	30	27	239	50	443	95	841
	50	39	345	98	867	186	1646
	80	63	558	137	1212	255	2257
	100	67	593	157	1389	284	2513

Item Model No.	Reduction Ratio	Rated Torque at 2000rpm		Limit for Repeated Peak Torque		Permissible Maximum Momentary Torque	
		N•m	In.lb	N•m	In.lb	N•m	In.lb
40	50	137	1212	402	3558	686	6071
	80	206	1823	519	4593	980	8673
	100	265	2345	568	5027	1080	9558
	120	294	2602	617	5460	1180	10443
45	50	176	1558	500	4425	950	8408
	80	313	2770	706	6248	1270	11240
	100	353	3124	755	6682	1570	13895
	120	402	3558	823	7284	1760	15576
50	50	245	2168	715	6328	1430	12656
	80	372	3292	941	8328	1860	16461
	100	470	4160	980	8673	2060	18231
	120	529	4682	1080	9558	2060	18231
58	50	529	4682	1180	10443	2450	21683
	80	529	4682	1180	10443	2450	21683
	100	529	4682	1180	10443	2450	21683
	120	529	4682	1180	10443	2450	21683

•Cross Roller Bearing Specification

Item Model No.	Basic Rated Load				Permissible Moment Load Mc		Moment Stiffness Km	
	Basic Dynamic Rated Load C		Basic Static Rated Load Co					
	x 10 ³ N	lb	x 10 ³ N	lb	N•m	In.lb	x 10 ⁴ N•m / rad	In.lb/arc-min
14	58	1304	86	1933	74	655	8.5	219
17	104	2338	163	3664	124	1097	15.1	389
20	146	3282	220	4946	187	1655	25.2	649
25	218	4901	358	8048	258	2283	39.2	1009
32	382	8587	654	14702	580	5133	100	2575
40	433	9734	816	18344	849	7514	179	4609
45	776	17444	1350	30348	1127	9974	257	6618
50	816	18344	1490	33495	1487	13160	351	9038
58	874	19648	1710	38441	2180	19293	531	13673

• "Basic dynamic rated load" is a constant stationary radial load that achieves a basic dynamic rated life of the bearing of one million revolutions.
"Basic static rated load" is a static load that achieves a contact stress of a constant level (408kN/mm²) at the center of a contact zone between the rolling element receiving a maximum load and track.

Unit: mm

Size Symbol	14	17	20	25	32	40	45	50	58
øA	54	64	75	90	115	140	160	172	201
B	52.5	56.5	51.5	55.5	65.5	79	85	93	106

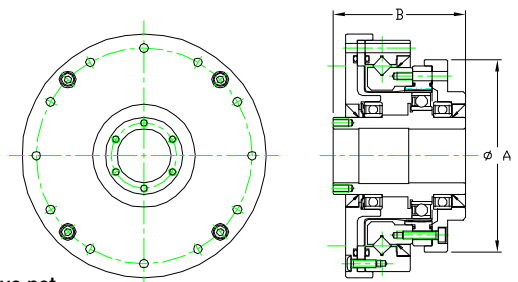

Drawings (DXF) can be downloaded from our home page. URL: <http://www.HarmonicDrive.net>

CSF Mini Series Unit

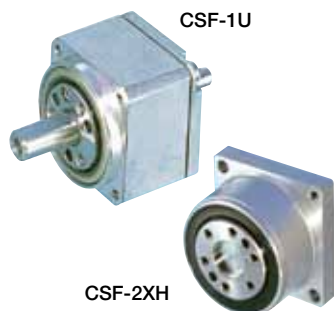

- Zero backlash, high positioning accuracy
- Compact and lightweight
- High torque capacity
- High radial, axial, and moment load capacity
- Features 4 point contact bearing
- Available in ratios from 30:1 up to 100:1
- Flange output
- Shaft output
- Shaft input and Output

L₁₀ Life: 7,000h

•CSF Mini Series Ratings

Item Model No.	Reduction Ratio	Rated Torque at 2000 rpm		Limit for Repeated Peak Torque		Permissible Maximum Momentary Torque	
		N•m	In.lb	N•m	In.lb	N•m	In.lb
3	30	0.06	0.53	0.13	1.15	0.22	1.95
	50	0.11	0.97	0.21	1.86	0.41	3.63
	100	0.16	1.42	0.3	2.66	0.57	5.04
5	30	0.25	2.2	0.5	4.4	0.9	8.0
	50	0.4	3.5	0.9	8.0	1.8	16
	100	0.6	5.3	1.4	12.4	2.7	24
8	30	0.9	8.0	1.8	16	3.3	29
	50	1.8	16	3.3	29	6.6	58
	100	2.4	21	4.8	42	9	80
11	30	2.2	19	4.5	40	8.5	75
	50	3.5	31	8.3	73	17	150
	100	5	44	11	97	25	221
14	30	4	35	9	80	17	150
	50	5.4	48	18	159	35	310
	80	7.8	69	23	204	47	416
	100	7.8	69	28	248	54	478

•4 Point Contact Bearing Specification

Item Model No.	Basic Rated Load				Permissible Moment Load Mc		Moment Stiffness Km	
	Basic Dynamic Rated Load C		Basic Static Rated Load Co		N•m	In.lb	N•m/rad	Inlb/arc.min
	x10 ² N	lb	x10 ² N	lb				
3	6.65	149	4.24	95	0.27	2	0.9x10 ²	0.2
5	9.14	205	7.63	172	0.89	8	7.41x10 ²	1.9
8	21.6	486	19.0	427	3.46	31	2.76x10 ³	1.7
11	38.9	874	35.4	796	6.6	58	7.41x10 ³	19.0
14	61.2	1376	58.5	1315	13.2	117	1.34x10 ⁴	34.5

Unit: mm

Model No.	3	5	8	11	14
Symbol					
øA	17.5	29	43.5	58	73
B	27	17	28.7	38.3	45
C	7	22	32	43	53

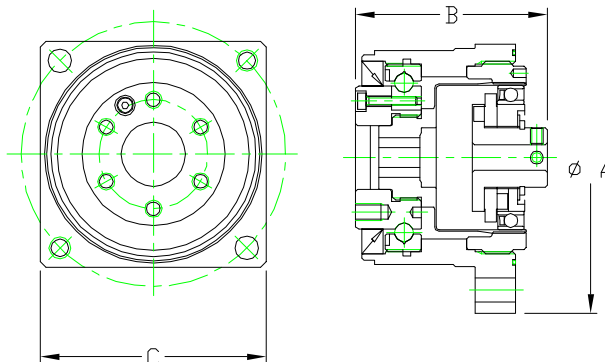
Drawings (DXF) can be downloaded from our home page. URL: <http://www.HarmonicDrive.net>

CSD-2UH Series



- Compact, Simple
- Lightness
- Hollow Shaft Construction

L₁₀ Life: 7,000 h

•CSD-2UH Series Ratings

Item Size	Ratio	Rated Torque at 2000 rpm		Repeated Peak Torque		Maximum Momentary Torque	
		N•m	In.lb	N•m	In.lb	N•m	In.lb
14	50	3.7	33	12	106	24	212
	100	5.4	48	19	168	35	310
17	50	11	97	23	204	48	425
	100	16	142	37	327	71	628
20	50	17	150	39	345	69	611
	100	28	248	57	504	95	841
	160	28	248	64	566	95	841
25	50	27	239	69	611	127	1124
	100	47	416	110	974	184	1628
	160	47	416	123	1089	204	1805
32	50	53	469	151	1336	268	2372
	100	96	850	233	2062	420	3717
	160	96	850	261	2310	445	3938
40	50	96	850	281	2487	480	4248
	100	185	1637	398	3522	700	6195
	160	206	1823	453	4009	765	6770
50	50	172	1522	200	1770	1000	8850
	100	329	2912	686	6071	1440	12744
	160	370	3275	823	7284	1715	15178

• Cross Roller Bearing Specification

Item Model No.	Basic Rated Load				Permissible Moment Load Mc		Moment Stiffness Km	
	Basic Dynamic Rated Load C		Basic Static Rated Load Co		N•m	In.lb	x10 ⁴ N.m/rad	In.lb/arc.min
	x10 ² N	lb	x10 ² N	lb				
14	47	1057	60.7	1365	41	363	3.48	90
17	52.9	1189	75.5	1697	64	566	7.75	200
20	57.8	1299	90	2023	91	805	12.8	330
25	96	2158	151	3394	156	1381	24.2	623
32	150	3372	250	5620	313	2770	53.9	1388
40	213	4788	365	8205	450	3983	91	2343
50	348	7823	602	13533	759	6717	171	4403

Unit: mm

Size	14	17	20	25	32	40	50
Symbol							
øA h7	55	62	70	85	112	126	157
B	25	26.5	29.5	37.1	43	51.7	62.5

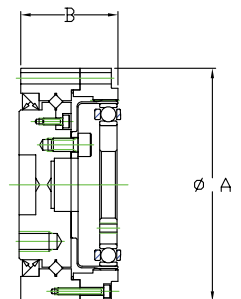
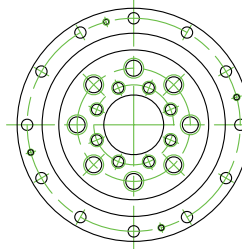

Hollow Shaft, Simplicity Unit

CSD-2UF Series



- Hollow shaft construction
- Compact , Lightness
- Increase the load capacity

L₁₀ Life: 7,000h

•CSD-2UF Series Ratings

Item Size	Ratio	Rated Torque at 2000 rpm		Repeated Peak Torque		Maximum Momentary Torque	
		N•m	In.lb	N•m	In.lb	N•m	In.lb
14	50	3.7	33	12	106	24	212
	100	5.4	48	19	168	35	310
17	50	11	97	23	204	48	425
	100	16	142	37	327	71	628
20	50	17	150	39	345	69	611
	100	28	248	57	504	95	841
	160	28	248	64	566	95	841
25	50	27	239	69	611	127	1124
	100	47	416	110	974	184	1628
	160	47	416	123	1089	204	1805
32	50	53	469	151	1336	268	2372
	100	96	850	233	2062	420	3717
	160	96	850	261	2310	445	3938
40	50	96	850	281	2487	480	4248
	100	185	1637	398	3522	700	6195
	160	206	1823	453	4009	765	6770

• Cross Roller Bearing Specification

Model No.	Item	Basic Rated Load				Permissible Moment Load Mc		Moment Stiffness Km	
		Basic Dynamic Rated Load C		Basic Static Rated Load Co		N•m	In.lb	x10 ⁴ N.m/rad	In.lb/arc.min
		x10 ² N	lb	x10 ² N	lb				
14		57.8	1299	90	2023	91	805	12.8	330
17		104	2338	163	3664	124	1097	15.4	397
20		146	3282	220	4946	187	1655	25.2	649
25		218	4901	358	8048	258	2283	39.2	1009
32		382	8587	654	14702	580	5133	100	2575
40		433	9734	816	18344	849	7514	179	4609

Unit: mm

Size	14	17	20	25	32	40
Symbol						
øA h7	70	80	90	110	142	170
B	22	22.7	26.8	31.5	37	45

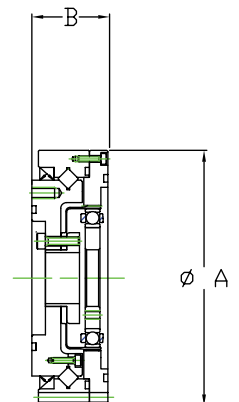
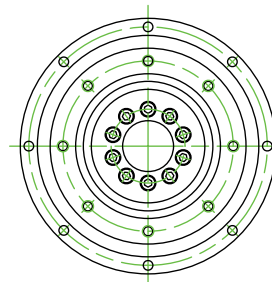

SHD Series



- Extremely flat profile
- Hollow thru bore
- High positioning accuracy
- High stiffness cross roller bearing output
- High radial, axial, and moment load capacity

L_{10} Life: 7,000 h

•SHD Series Ratings

Item Model No.	Reduction Ratio	Rated Torque at 2000 rpm		Limit for Repeated Peak Torque		Permissible Maximum Momentary Torque	
		N•m	In.lb	N•m	In.lb	N•m	In.lb
14	50	3.7	33	12	106	23	204
	100	5.4	48	19	168	35	310
17	50	11	97	23	204	48	425
	100	16	142	37	327	71	628
20	50	17	150	39	345	69	611
	100	28	248	57	504	95	841
	160	28	248	64	566	95	841
25	50	27	239	69	611	127	1124
	100	47	416	110	974	184	1628
	160	47	416	123	1089	204	1805
32	50	53	469	151	1336	268	2372
	100	96	850	233	2062	420	3717
	160	96	850	261	2310	445	3938
40	50	96	850	281	2487	480	4248
	100	185	1637	398	3522	700	6195
	160	206	1823	453	4009	765	6770

•Cross Roller Bearing Specification

Item Model No.	Basic Rated Load				Permissible Moment Load Mc		Moment Stiffness Km	
	Basic Dynamic Rated Load C		Basic Static Rated Load Co		N•m	In.lb	x10 ⁴ N•m/rad	In.lb /arc-min
	x10 ³ N	lb	x10 ³ N	lb				
14	29	652	43	967	37	327	7.08	182
17	52	1169	81	1821	62	549	12.7	327
20	73	1641	110	2473	93	823	21	541
25	109	2450	179	4024	129	1142	31	798
32	191	4294	327	7351	290	2567	82.1	2114
40	216	4856	408	9172	424	3752	145	3734

• “Basic dynamic rated load” is a constant stationary radial load that achieves a basic dynamic rated life of the bearing of one million revolutions.
 “Basic static rated load” is a static load that achieves a contact stress of a constant level (4kN/mm²) at the center of a contact zone between the rolling element receiving a maximum load and track.

Unit: mm

Model No.	14	17	20	25	32	40
Symbol						
øA	70	80	90	110	142	170
B	17.5	18.5	19	22	27.9	33

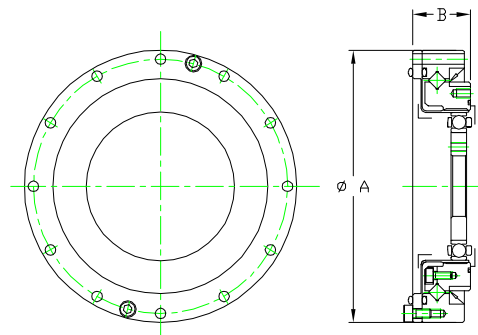

Pancake Type
FB and FR Series

FB

FR

- Flat profile
- Easily adapted to customer supplied assembly
- FB type uses single wave generator bearing
- FR is heavy duty version of the FB
- FR uses double wave generator bearing

L₁₀ Life: 3,000 h

• **FB, FR Series Ratings**

Size	Ratio	Rated Torque at 2000rpm			
		FB Series		FR Series	
		N•m	In.lb	N•m	In.lb
14	50	2.6	23	4.4	39
	88	4.9	43	5.9	52
	100	5.9	52	7.8	69
	110	5.9	52	7.8	69
20	50	14	124	25	221
	80	17	150	34	301
	100	22	195	40	354
	128	24	212	40	354
	160	24	212	40	354
25	50	23	204	39	345
	80	31	274	56	496
	100	39	345	67	593
	120	39	345	67	593
	160	39	345	67	593
	200	-	-	67	593
32	50	44	389	76	673
	78	63	558	108	956
	100	82	726	137	1212
	131	82	726	137	1212
	157	82	726	137	1212
	200	-	-	137	1212
	260	-	-	137	1212
	260	-	-	137	1212
40	50	88	779	137	1212
	80	118	1044	196	1735
	100	157	1389	255	2257
	128	167	1478	294	2602
	160	167	1478	294	2602
	200	-	-	294	2602
	258	-	-	294	2602
	258	-	-	294	2602

Size	Ratio	Rated Torque at 2000rpm			
		FB Series		FR Series	
		N•m	In.lb	N•m	In.lb
50	80	216	1912	363	3213
	100	284	2513	470	4160
	120	304	2690	559	4947
	160	304	2690	559	4947
	200	-	-	559	4947
	242	-	-	559	4947
65	78	-	-	745	6593
	104	-	-	1070	9470
	132	-	-	1070	9470
	158	-	-	1070	9470
	208	-	-	1070	9470
	260	-	-	1070	9470
80	80	-	-	1320	11682
	96	-	-	1660	14691
	128	-	-	2300	20355
	160	-	-	2350	20798
	194	-	-	2350	20798
	258	-	-	2350	20798
100	80	-	-	2330	20621
	100	-	-	3200	28320
	120	-	-	3890	34427
	160	-	-	4470	39560
	200	-	-	4470	39560
	242	-	-	4470	39560
320	-	-	4470	39560	

Unit: mm

Size	Symbol	FB	FR
	∅A	B	C
14	50	10.5	18
20	70	12.5	25
25	85	16.5	29
32	110	20.5	37
40	135	27.0	43
50	170	33.0	53
65	215	-	71
80	265	-	83
100	330	-	101

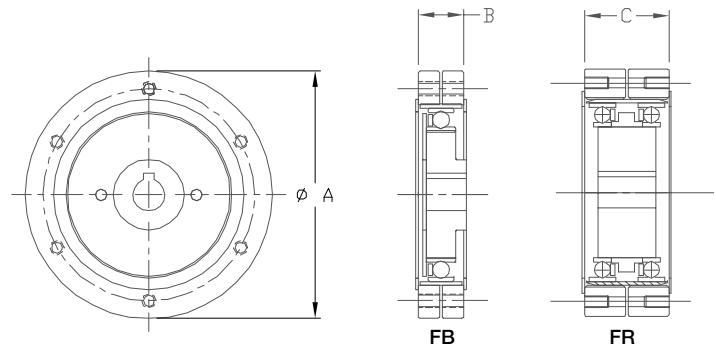

Phasing Differential FD Series Unit Type



- Pancake type
- Ultra compact differential unit
- Backlash is very small and unit requires no assembly adjustment.

• FD Series Ratings

Size	Gear Ratio	Rotational Speed r/min.									
		3500 RPM		2850 RPM		1450 RPM		960 RPM		500 RPM	
		N•m	In.lb	N•m	In.lb	N•m	In.lb	N•m	In.lb	N•m	In.lb
20	80	29	257	30	266	30	266	30	266	30	266
	100	30	266	31	274	36	319	36	319	36	319
	128	31	274	34	301	43	381	43	381	43	381
	160	32	283	35	310	45	398	49	434	49	434
25	80	46	407	50	443	57	504	57	504	57	504
	100	49	434	53	469	67	593	79	699	79	699
	120	52	460	55	487	70	620	82	726	96	850
	160	54	478	57	504	73	646	83	735	108	956
200	55	487	59	522	74	655	84	743	108	956	
	78	98	867	108	956	108	656	108	956	108	956
	100	108	956	118	1044	147	1301	157	1389	157	1389
	131	108	956	118	1044	157	1389	176	1558	206	1823
32	157	108	956	118	1044	157	1389	176	1558	216	1912
	200	108	956	118	1044	157	1389	176	1558	216	1912
	260	108	956	118	1044	157	1389	176	1558	216	1912
	80	196	1735	196	1735	196	1735	196	1735	196	1735
40	100	235	2080	245	2168	265	2345	265	2345	265	2345
	128	235	2080	245	2168	314	2779	363	3213	372	3292
	160	235	2080	245	2168	314	2779	363	3213	451	3991
	200	235	2080	245	2168	314	2779	363	3213	451	3991
258	235	2080	245	2168	314	2779	363	3213	451	3991	
	80	353	3124	353	3124	353	3124	353	3124	353	3124
	100	441	3903	470	4160	559	4947	559	4947	559	4947
	120	441	3903	470	4160	588	5204	666	5894	666	5894
50	160	441	3903	470	4160	588	5204	676	5983	843	7461
	200	441	3903	470	4160	588	5204	676	5983	843	7461
	242	441	3903	470	4160	588	5204	676	5983	843	7461
	78	-	-	-	-	764	6761	764	6761	764	6761
65	104	-	-	-	-	1100	9735	1190	10532	1190	10532
	132	-	-	-	-	1100	9735	1250	11063	1570	13895
	158	-	-	-	-	1100	9735	1250	11063	1570	13895
	208	-	-	-	-	1100	9735	1250	11063	1570	13895
260	-	-	-	-	-	1100	9735	1250	11063	1570	13895
	80	-	-	-	-	1370	12125	1370	12125	1370	12125
	96	-	-	-	-	1800	15930	1800	15930	1800	15930
	128	-	-	-	-	2180	19293	2490	22037	2710	23984
80	160	-	-	-	-	2180	19293	2490	22037	3130	27701
	194	-	-	-	-	2180	19293	2490	22037	3130	27701
	258	-	-	-	-	2180	19293	2490	22037	3130	27701
	320	-	-	-	-	2180	19293	2490	22037	3130	27701
100	80	-	-	-	-	2470	21860	2470	21860	2470	21860
	100	-	-	-	-	3720	32922	3720	32922	3720	32922
	120	-	-	-	-	3980	35223	4560	40356	4740	41949
	160	-	-	-	-	3980	35223	4560	40356	5720	50622
200	-	-	-	-	-	3980	35223	4560	40356	5720	50622
	242	-	-	-	-	3980	35223	4560	40356	5720	50622
	320	-	-	-	-	3980	35223	4560	40356	5720	50622

Unit: mm

Model No.	20	25	32	40	50	65	80	100
Symbol								
øA	85	95	120	145	185	235	290	360
B	73	81	95	113	132	147	178	212

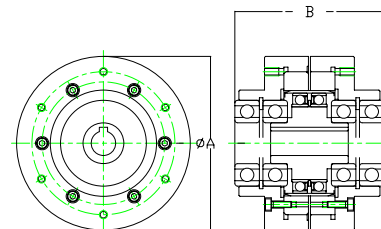



Phasing Differential

FD Series Component Type



- Pancake type
- Ultra compact differential unit
- Backlash is very small and unit requires no assembly adjustment.

• FD Series Ratings

Size	Gear Ratio	Rotational Speed r/min.									
		3500 RPM		2850 RPM		1450 RPM		960 RPM		500 RPM	
		N•m	In.lb	N•m	In.lb	N•m	In.lb	N•m	In.lb	N•m	In.lb
20	80	29	257	30	266	30	266	30	266	30	266
	100	30	266	31	274	36	319	36	319	36	319
	128	31	274	34	301	43	381	43	381	43	381
	160	32	283	35	310	45	398	49	434	49	434
25	80	46	407	50	443	57	504	57	504	57	504
	100	49	434	53	469	67	593	79	699	79	699
	120	52	460	55	487	70	620	82	726	96	850
	160	54	478	57	504	73	646	83	735	108	956
25	200	55	487	59	522	74	655	84	743	108	956
	78	98	867	108	956	108	656	108	956	108	956
	100	108	956	118	1044	147	1301	157	1389	157	1389
	131	108	956	118	1044	157	1389	176	1558	206	1823
32	157	108	956	118	1044	157	1389	176	1558	216	1912
	200	108	956	118	1044	157	1389	176	1558	216	1912
	260	108	956	118	1044	157	1389	176	1558	216	1912
	80	196	1735	196	1735	196	1735	196	1735	196	1735
40	100	235	2080	245	2168	265	2345	265	2345	265	2345
	128	235	2080	245	2168	314	2779	363	3213	372	3292
	160	235	2080	245	2168	314	2779	363	3213	451	3991
	200	235	2080	245	2168	314	2779	363	3213	451	3991
40	258	235	2080	245	2168	314	2779	363	3213	451	3991
	80	353	3124	353	3124	353	3124	353	3124	353	3124
	100	441	3903	470	4160	559	4947	559	4947	559	4947
	120	441	3903	470	4160	588	5204	666	5894	666	5894
50	160	441	3903	470	4160	588	5204	676	5983	843	7461
	200	441	3903	470	4160	588	5204	676	5983	843	7461
	242	441	3903	470	4160	588	5204	676	5983	843	7461
	78	-	-	-	-	764	6761	764	6761	764	6761
65	104	-	-	-	-	1100	9735	1190	10532	1190	10532
	132	-	-	-	-	1100	9735	1250	11063	1570	13895
	158	-	-	-	-	1100	9735	1250	11063	1570	13895
	208	-	-	-	-	1100	9735	1250	11063	1570	13895
65	260	-	-	-	-	1100	9735	1250	11063	1570	13895
	80	-	-	-	-	1370	12125	1370	12125	1370	12125
	96	-	-	-	-	1800	15930	1800	15930	1800	15930
	128	-	-	-	-	2180	19293	2490	22037	2710	23984
80	160	-	-	-	-	2180	19293	2490	22037	3130	27701
	194	-	-	-	-	2180	19293	2490	22037	3130	27701
	258	-	-	-	-	2180	19293	2490	22037	3130	27701
	320	-	-	-	-	2180	19293	2490	22037	3130	27701
100	80	-	-	-	-	2470	21860	2470	21860	2470	21860
	100	-	-	-	-	3720	32922	3720	32922	3720	32922
	120	-	-	-	-	3980	35223	4560	40356	4740	41949
	160	-	-	-	-	3980	35223	4560	40356	5720	50622
100	200	-	-	-	-	3980	35223	4560	40356	5720	50622
	242	-	-	-	-	3980	35223	4560	40356	5720	50622
	320	-	-	-	-	3980	35223	4560	40356	5720	50622

Unit: mm

Model No.	20	25	32	40	50	65	80	100
Symbol								
øA	70	85	110	135	170	215	265	330
B	25	29	37	43	53	71	83	101

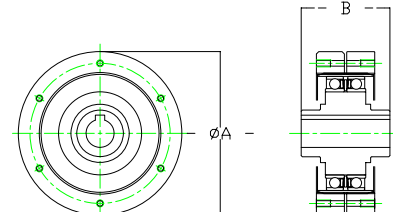

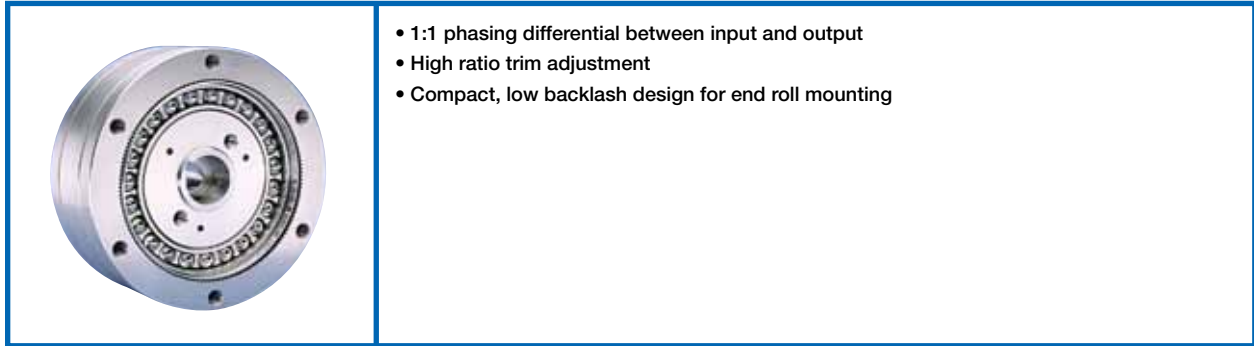

- 1:1 phasing differential between input and output
- High ratio trim adjustment
- Compact, low backlash design for end roll mounting

• HDB Series Ratings

Size	Ratio	Limit for Repeated Peak Torque		Maximum Momentary Input RPM		Rated Output Torque									
						Input Speed									
						500 RPM		1000 RPM		1500 RPM		2000 RPM		3000 RPM	
lb-in	Nm	Oil	Grease	lb-in	Nm	lb-in	Nm	lb-in	Nm	lb-in	Nm	lb-in	Nm		
20	80	250	28	6000	3500	373.3	42	296	33	259	29	235	27	206	23
	100	300	34												
	120	350	40												
	160	390	44												
25	80	425	48	5000	3500	616.2	70	489	55	427	48	388	44	339	38
	100	600	68												
	120	700	79												
	160	780	88												
32	80	950	107	4500	3500	1229	139	976	110	853	96	775	88	677	76
	100	1200	136												
	120	1400	158												
	160	1550	175												
40	80	1700	192	4000	3000	2588	292	2054	232	1795	203	1631	184	1425	161
	100	2400	271												
	120	2700	305												
	160	3100	350												
50	80	3100	350	3500	2500	4826	545	3831	433	3347	378	3042	344	2658	300
	100	4200	475												
	120	5200	588												
	160	5800	655												

HDB	No Load Starting Torque	No Load Starting Torque	Input Inertia	Input Inertia
	in-oz	Ncm	ib in ²	kgcm ²
20	4.5	3.2	0.049	0.143
25	6	4.2	0.124	0.363
32	8	5.7	0.45	1.32
40	27	19.1	1.17	3.42
50	50	35.3	3.39	9.91

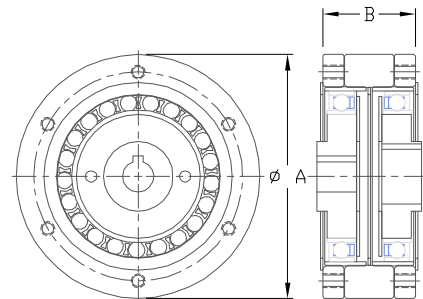

Unit: mm

Model No.	20	25	32	40	50
Symbol					
ø A	70	85	110	134	170
B	26.5	34.8	42	56.5	-

**High-performance Harmonic Drive™ Gear Head
Quick Connect Type for Servomotors**

Speed reducer

CSF-GH Series

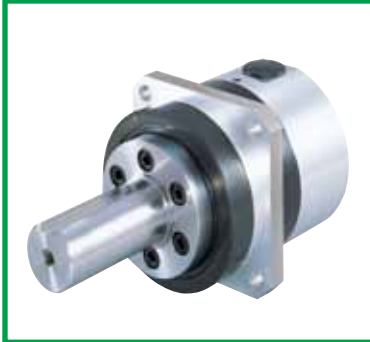

This quick connect design allows easy installation and mounting to a wide variety of servo motors

- Easy mounting to various servomotor manufacturers
- Zero backlash
- High moment capacity cross roller output bearing

L₁₀ Life: 7,000 h

•CSF-GH Series Ratings

Item Model No.	Reduction Ratio	Output Torque at 2000rpm		Limit for Repeated Peak Torque		Maximum Momentary Torque	
		N•m	In.lb	N•m	In.lb	N•m	In.lb
14	50	5.4	48	18	159	35	310
	80	7.8	69	23	204	47	416
	100	7.8	69	28	248	54	478
20	50	25	221	56	496	98	867
	80	34	301	74	655	127	1124
	100	40	354	82	726	147	1301
	120	40	354	87	770	147	1301
	160	40	354	92	814	147	1301
32	50	76	673	216	1912	382	3381
	80	118	1044	304	2690	568	5027
	100	137	1212	333	2947	647	5726
	120	137	1212	353	3124	686	6071
	160	137	1212	372	3292	686	6071
45	50	176	1558	500	4425	950	8408
	80	313	2770	706	6248	1270	11240
	100	353	3124	755	6682	1570	13895
	120	402	3558	823	7284	1760	15576
65	160	402	3558	882	7806	1910	16904
	80	745	6593	2110	18674	3720	32922
	100	951	8416	2300	20355	4750	42038
	120	951	8416	2510	22214	4750	42038
	160	951	8416	2630	23276	4750	42038

•Cross Roller Bearing Specification

Item Model No.	Basic Rated Load				Permissible Moment Load Mc		Moment Stiffness Km	
	Basic Dynamic Rated Load C		Basic Static Rated Load Co		N•m	In.lb	×10 ⁴ N•m/rad	In.lb/ arc.min
	×10 ⁴ N	lb	×10 ⁴ N	lb				
14	51.1	1149	70.6	1587	27	239	30	773
20	106	2383	173	3889	145	1283	17	438
32	205	4608	328	7373	258	2283	42	1082
45	416	9352	760	17085	797	7053	100	2575
65	816	18344	1490	33495	2156	19081	323	8317

• "Basic dynamic rated load" is a constant stationary radial load that achieves a basic dynamic rated life of the bearing of one million revolutions.
 "Basic static rated load" is a static load that achieves a contact stress of a constant level (4kN/mm²) at the center of a contact zone between the rolling element receiving a maximum load and track.

•Corresponding servomotor capacity

The CSF-GH series is designed to mount to a range of servo motors with output power ranging from 30W to 5000W.

Unit: mm					
Size	14	20	32	45	65
Symbol					
A	60	90	120	170	230
B	21	27	35	53	57
C (ref.)	55	72	105.5	128	157
D	37	53	98	103	135
øE	16	25	40	50	70

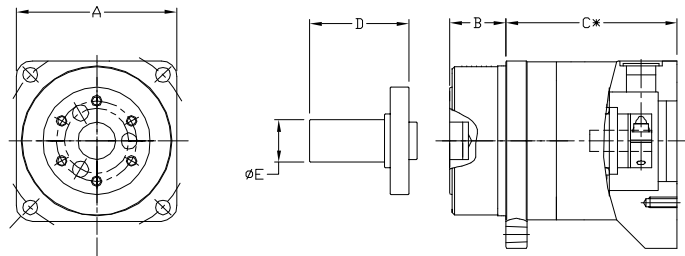

* The length and shape of the motor adapter flange will depend upon the specific motor that is selected for use with the gearhead. Please contact Harmonic Drive LLC for a detailed drawing.

HPG Series



- High precision Planetary gearhead
- Low backlash: Less than 3 arc min (less than 1 arc min optional)
- Reduction ratios between 3:1 and 45:1
- Easy mounting to various servomotor manufacturers
- High torque capacity
- High moment capacity cross roller output bearing
- High efficiency, 90% or higher (85% for Model 14)
- Sealed structure
- Shaft input as well as flange and shaft output versions available

L_{10} Life: 10,000 h

•HPG Series Ratings

Model No.	Gear Ratio	274 Rated Torqu584e at 3000 rp779m 814		Repeated Peak Torque		Max. Momentary Peak Torque	
		N•m	In.lb	N•m	In.lb	N•m	In.lb
		5	2.5	22	7.8	69	20
11	9	2.5	22	3.9	35	20	177
	21	3.4	30	9.8	87	20	177
	37	3.4	30	9.8	87	20	177
	45	3.4	30	9.8	87	20	177
	3	2.9	26	15	133	37	327
14	5	5.9	52	23	204	56	496
	11	7.8	69	23	204	56	496
	15	9.0	80	23	204	56	496
	21	9	78	23	204	56	496
	33	10	89	23	204	56	496
20	45	10	89	23	204	56	496
	3	8.8	78	64	566	124	1097
	5	16	142	100	885	217	1920
	11	20	177	100	885	217	1920
	15	24	212	100	885	217	1920
32	21	25	221	100	885	217	1920
	33	29	257	100	885	217	1920
	45	29	257	100	885	217	1920
	3	31	274	225	1991	507	4487
	5	66	584	300	2655	650	5753
	11	88	779	300	2655	650	5753
	15	92	814	300	2655	650	5753
50	21	98	867	300	2655	650	5753
	33	108	956	300	2655	650	5753
	45	108	956	300	2655	650	5753
	3	97	858	657	5814	1850	16373
	5	170	1505	850	7523	1850	16373
	11	200	1770	850	7523	1850	16373
	15	230	2036	850	7523	1850	16373
65	21	260	2301	850	7523	1850	16373
	33	270	2390	850	7523	1850	16373
	45	270	2390	850	7523	1850	16373
	4	500	4425	2200	19470	4500	39825
	5	530	4691	2200	19470	4500	39825
	12	600	5310	2200	19470	4500	39825
	15	730	6461	2200	19470	4500	39825
65	20	800	7080	2200	19470	4500	39825
	25	850	7523	2200	19470	4500	39825

•Cross Roller Bearing Specification

Item	Basic Rated Load				Allowable Moment Load MC		Moment Stiffness Km	
	Basic Dynamic Rated Load C		Basic Static Rated Load Co		N•m	In.lb	x10 ⁴ N•m/rad	In.lb/ arc-min
	x10 ² N	lb	x10 ² N	lb				
11	31.16	700	40.87	919	9.50	84	0.88	23
14	51.1	1149	70.6	1587	32.3	286	3.0	77
20	106	2383	173	3889	183	1620	16.8	433
32	206	4631	328	7373	452	4000	42.1	1084
50	416	9352	760	17085	1076	9523	100	2575
65	906	20367	1480	33270	3900	34515	364	9373

•Corresponding servomotor capacity

The HPG series is designed to mount to a range of servo motors with output power ranging from 30W to 5000W.

Unit: mm

Size	11	14	20	32	50	65
A	40	60	90	120	170	230
B	15	21	27	35	53	57
C (ref.)	30.5	64	71	104	123	184.5
D	27	37	53	98	103	-
øE	8	16	25	40	50	-

*The length and shape of the motor adapter flange will depend upon the specific motor that is selected for use with the gearhead. Please contact Harmonic Drive LLC for a detailed drawing.
--- Size 65 – Shaft is available as special request. ---

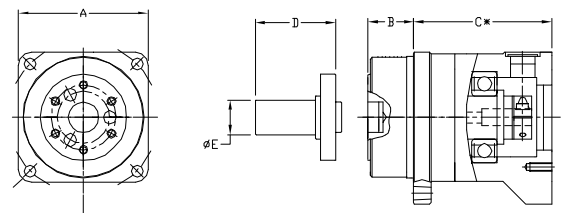

HPG RA Series



- High precision Planetary gearhead
- Low backlash: Less than 3 arc min (less than 1 arc min optional)
- Easy mounting to various servomotor manufacturers
- High torque capacity
- High moment capacity cross roller output bearing
- Right angle configuration allows for use in limited space

•HPG RA Series Ratings

Size	Ratio	Rated Torque		Max. Average Load Torque		Limit for Repeated Peak Torque		Max. Momentary Torque	
		N•m	In.lb	N•m	In.lb	N•m	In.lb	N•m	In.lb
32	5	66	584	150	1328	150	1328	650	5753
	11	88	779	170	1505	300	2655		
	15	92	814	170	1505				
	21	98	867	170	1505				
50	5	170	1505	340	3009	400	3540	1850	16373
	11	200	1770	400	3540				
	15	230	2036	450	3983				
	21	260	2301	500	4425				
	33	270	2390	500	4425				
	45	270	2390	500	4425				
65	5	400	3540	400	3540	400	3540	4500	39825
	12	600	5310	960	8496				
	15	730	6461	1200	10620				
	20	800	7080	1500	13275				
	25	850	7523	1500	13275				

•Cross Roller Bearing Specification

Item	Basic Rated Load				Allowable Moment Load MC		Moment Stiffness Km	
	Basic Dynamic Rated Load C		Basic Static Rated Load Co		N•m	In.lb	x10 ⁴ N•m/rad	In.lb/ arc-min
	x10 ² N	lb	x10 ² N	lb				
32	205	4608	328	7373	452	4000	42.1	1084
50	416	9352	760	17085	1076	9523	100	2575
65	906	20367	1480	33270	3900	34515	364	9373

Unit: mm

Size	A	øB	C	D	*E	F	G
32	120	115H7	35	107	140/175	175/197/217	130/180/220
50	170	165H7	53	144	168/200	209/234/254	130/180/220
65	230	220H8	57	226	168/200	291/316/336	130/180/220

*E
 Left side description: The limited length of the Motor shaft is 81mm.
 Right side description: The limited length of the Motor shaft is 116mm.

Note:
 Dimensions F & G depend on the chosen Motor flange square size.
 Contact Harmonic Drive LLC for special flange motor combination.

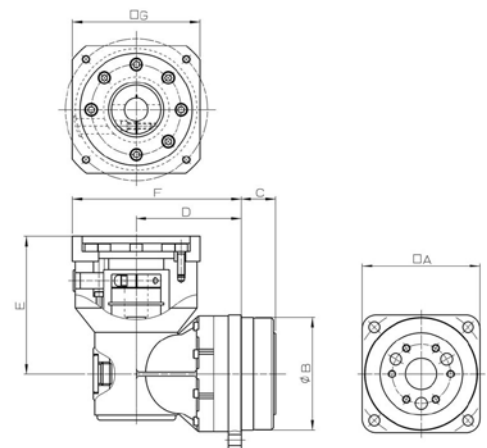

HDI Infnit-Indexer® Phase Adjuster



- Fine tune rotational position of shafts and machine parts
- Phase cams
- Adjust roll registration
- Take up backlash in spur and worm gears
- Synchronize indexing devices

Infnit-Indexers® are available from immediate stock in the standard bore sizes shown with keyways, set screws, and tapped holes for face mounting of either hub. It is possible for the user to modify these configurations by disassembling the unit. The hub material is low carbon steel with suitable sizes shown in notes to the dimensional drawings. Additional sizes and configurations are available by special order.

•3 Models, 6 Bore Sizes Available From Stock

HDI Size	Bore Size	O.D.	Length	Torque Capacity
-10	1/2"	2 3/8" (60.33mm)	1 11/16" (42.9mm)	1000 lb-in (113 Nm)
	5/8"			
	3/4"			
-25	3/4"	3" (76.2mm)	2 3/16" (76.2mm)	2500 lb-in (283 Nm)
	1"			
-50	1 1/4"	3 3/4" (95.3mm)	2 3/8" (95.3mm)	5000 lb-in (565 Nm)

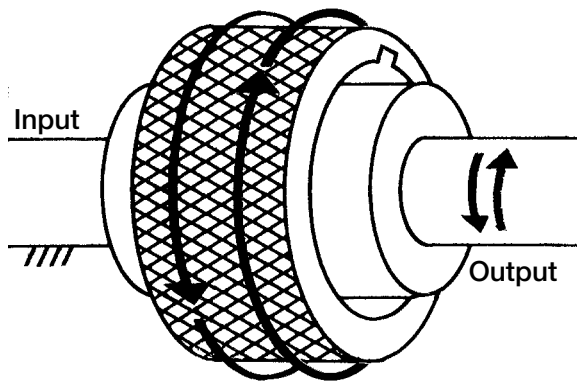

To operate, hand rotate the adjusting ring in either direction to produce a 100:1 reduction between the ring and the output. Adjust the friction adjustment/locking screw to desired resistance. For some applications, one adjustment will be sufficient for both shaft turning and phase adjusting modes. For more severe loading, such as hard stops or high peak torque situations, the friction adjustment/locking screw may be used to lock the adjusting ring in place to maintain phase.

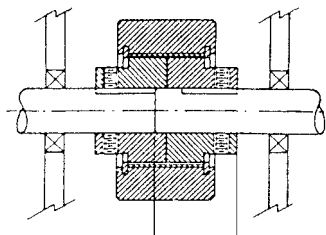

IN-LINE SHAFT

HDI Size	L DIM
-10	1.09
-25	1.34
-50	1.43

Flexible Couplings

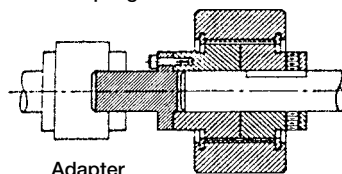

Adapter

IN-LINE SHAFT

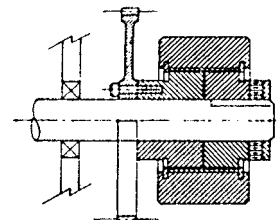

CONCENTRIC SHAFT

Unit : inch

Size	10	10	10	25	25	50
øA	2.38	2.38	2.38	3.00	3.00	3.75
B	1.69	1.69	1.69	2.19	2.19	2.37
øC	0.500	0.625	0.750	0.750	1.000	1.250
D	1.38	1.38	1.38	1.75	1.75	2.17

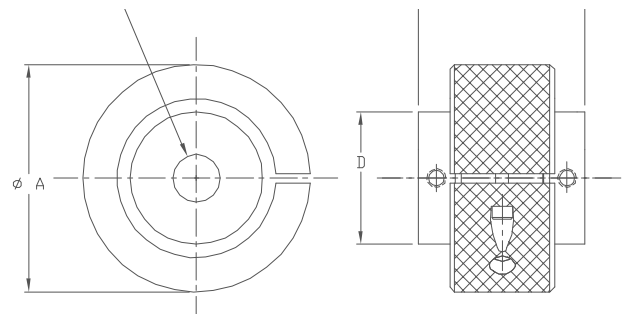

Applications

Robots



Industrial robots
Robot peripheral equipment

Primary axis
End effectors
Linear axis
Indexing table
Peripheral equipment

- FHA-Mini
- FHA-C
- RSF
- Micro Encoder

- CSG
- CSD
- CSF
- SHG
- SHF
- SHD
- HPG

Humanoid Robots

Humanoid Robots

Joint articulation
Robotic hand
Vision sensor positioning
Torque sensing

- FHA-Mini
- FHA-C
- RSF-Supermini
- RSF-Mini
- Micro Encoder

- CSG
- CSD
- CSF
- SHG
- SHF
- SHD
- HPG



Metal Machine Tools



Machining centers
Turning centers
NC lathes
Work transfer systems
Grinders
EDM systems

Tool changer
Tool magazine
Work positioning equipment
Rotary table
C Axis

- FHA-C
- RSF
- LAH
- CSG
- CSF
- SHG
- SHF
- HPG

Metal Working Machines

Bending machines
Rolling machines
Presses
Work transfer systems

Bending axis
Work positioning
Work transfer

- FHA-C
- RSF
- LSA
- SHG
- SHF
- HPG



Printing, Bookbinding and Paper Processing Machines



Printing presses
Folding machines
Paper changing machines
Paper positioning machines
Paper machines

Web tension control
Cutting blade positioning
Phase adjusting
Head box slice lip positioning
Roller height adjustment

- FHA-C
- RSF
- CSG
- CSF
- SHG
- SHF
- FB
- FR
- FD
- HPG

Semiconductor Manufacturing Systems



Mask and reticle manufacturing
 Wafer fabrication equipment
 Wafer processing equipment
 Test & Assembly equipment
 Inspection equipment
 Wafer transfer equipment

Wafer transfer robots
 Positioning drive
 Indexing tables
 Wafer flipper
 Valve opening/closing

FHA-Cmini	Micro Encoder
FHA-C	CSF
RSF	SHD
RSF-Supermini	SHF
KDU	HPG
RH	
LA	
LAH	

Photometric equipment
 Three-dimensional measuring instruments
 Metal tensile test machines
 Soil-column yield strength test machines

Transfer systems
 Positioning drive
 Prism positioning drive
 Indexing tables
 Direct transmission tables

FHA-C mini
RSF
RSF-Supermini
KDU
RH
LSA
Micro Encoder

CSF
SHF



Medical Equipment



Three-dimensional manipulators
 X-ray photographing and CT-NMR systems
 X-ray film developing and take-off machines
 Surgical operation assistant robots

Precision joint drive
 Bed lifting and inclination drive
 Positioning table drive

FHA-Cmini
FHA-C
RSF
RH
CSF
SHF

Optical Machines

X-ray analytical systems
 Optical component inspection systems
 Laser oscillation machines
 Optical measuring instruments
 Surface inspection systems
 Optical disc manufacturing systems
 Laser markers

Positioning table drive
 Lens positioning drive
 Laser mirror drive
 Prism drive
 Probe drive
 Sensor positioning drive

FHA-Cmini
RSF
RSF-Supermini
KDU
RH
LSA
Micro Encoder
CSF
SHF

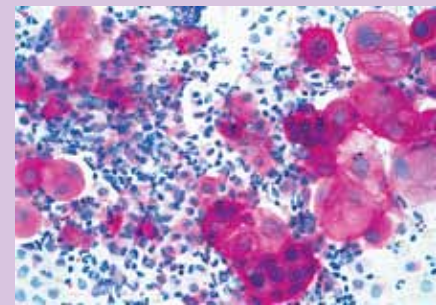

Telescopes



Condenser mirror adjusting mechanisms
 Electromagnetic wave micrometer adjusting mechanisms
 Secondary mirror position control
 Robot arms for maintenance servicing

X, Y, Z axis drive
 Indirect drive mechanisms

FHA-Cmini
RSF-Supermini
RSF
KDU
LA
LAH
LBC
CSF
SHF
HPG

Applications

Wood, Light Metal and Plastic Machine Tools



Woodworking machines
5-shaft machining centers
Large 3-dimension processing machines
Work transfer systems

- Milling head drive
- Tool revolver drive
- Tool changer drive
- Tool magazine drive
- Work positioning machines
- Rotary table drive
- Tool positioning machine drive
- Direct transmission shaft drive
- Shaft drive

- FHA-Cmini
- FHA-C
- RSF
- RSF-Supermini
- LAH
- CSG
- CSF
- SHG
- SHF
- HPG

Energy

Oil exploration robot
Wind power equipment
Electric power equipment
Photovoltaics

- Digging angle positioning drive
- Propeller angle positioning drive
- Condensing board positioning drive

- FHA-C
- CSF
- FR



Paper-making Machines



Paper-making machines
Corrugated fiberboard box making and printing machines

- Coating-process roller positioning drive
- Paper thickness adjusting mechanism drive
- Cutter knife positioning
- Cutter knife traveling drive

- RSF
- FHA-C
- RH
- CSF
- SHF
- HPG

Crating and Packaging Machines

Sealing machines
Label printing machines
Label attaching machines
Robots
Work transfer systems

- Shaft synchronizing drive
- Roll synchronizing drive
- Joint drive
- Trolley drive

- FHA-C
- RSF
- RH
- CSF
- SHF
- FB
- FR
- FD

- HPG



Flat Panel Display Manufacturing Systems



Array process equipment
Cell process equipment
Assembly process equipment
Work transfer systems

- Transfer systems
- Parts positioning drive
- Indexing tables
- Direct transmission tables
- Work reversing machines
- Tension controllers
- Hatch opening/closing drive
- Joint drive
- Trolley drive

- FHA-Cmini
- FHA-C
- RSF
- RSF-Supermini
- KDU
- RH
- LA
- LAH

- CSF
- SHF
- SHD
- HPG

Communication Equipment



Antennas
Microphones
Cameras
Wavelength duplexers
Radars

Pan & Tilt drives
Prism drive

FHA-C mini
FHA-C
RSF
RSF-Supermini
RH
LA
LSA
HPG

Micro Encoder

Electronic component insertion machines
Solder paste dispensing machines
Board inspection systems
Transfer systems

Drilling head drive
Tool changer drive
Tool magazine drive
Work positioning machines
Rotary table drive
Tool positioning machine drive
Shaft drive

FHA-C mini
FHA-C
RSF
RSF-Supermini
LAH
CSG
CSF
SHG
SHF
HPG



Space Equipment



Communication
Antennas
Solar cell paddles
Robotic joints
Robotic arms

Pan & Tilt drive
Joint drive
Wheel drive

CSF
SHF
SHD

Aircraft

Flight simulators
Cargo handling and transfer systems
Reconnaissance cameras
Valves

Valve actuator
Trolley drive
Cargo wheel power drive unit
Fly-by-Wire Components

FHA-Cmini
FHA-C
RSF
RSF-Supermini
RH
CSF
HPG



Glass and Ceramic Manufacturing Systems



Ceramic forming machines
Glass polishing machines
Sheet glass cutting machines

Valve opening and closing
Valve positioning
Traveling trolley drive

FHA-Cmini
FHA-C
RSF
LSA
CSF
SHF
HPG



Robots



Humanoid Robots



**Printing, Bookbinding
and Paper**

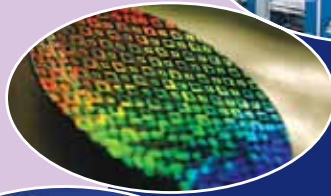

**Semiconductor Manufacturing
Systems**



Optical Machines



**Wood, Light Metal and Plastic
Machine Tools**

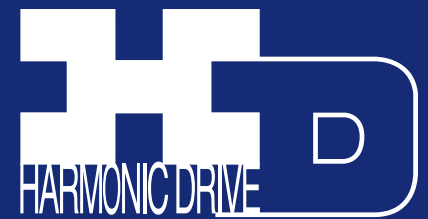

Paper-making Machines



**Flat Panel Display
Manufacturing Systems**



**Printed Circuit Board
Manufacturing Machines**



Aircraft



Metal Working Machine



Processing Machines



Measurement, Analytical and Test Systems



Medical Equipment



Telescopes



Energy



Crating and Packaging Machines



Communication Equipment



Space Flight



Glass and Ceramic Manufacturing Systems

Primary Application Areas

All products are warranted to be free from design or manufacturing defects for a period of one year from the date of shipment. Such items will be repaired or replaced at the direction of Harmonic Drive LLC. The seller makes no warranty, express or implied, concerning the material to be furnished other than it shall be of the quality and specifications stated. The seller's liability for any breach is limited to the purchase price of the product. All efforts have been made to assure that the information in this catalog is complete and accurate. However, Harmonic Drive LLC is not liable for any errors, omissions or inaccuracies in the reported data. Harmonic Drive LLC reserves the right to change the product specifications, for any reason, without prior notice.

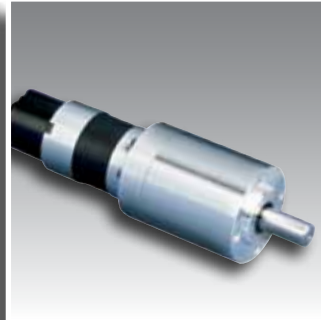
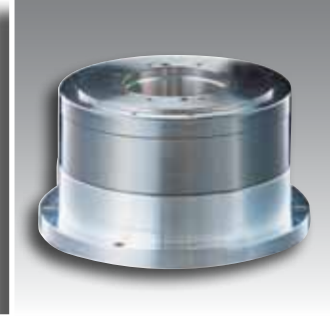
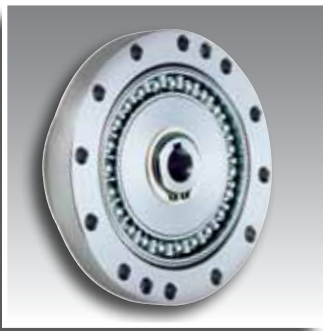

Harmonic Drive LLC

247 Lynnfield Street
Peabody, MA 01960

T: 800.921.3332
T: 978.532.1800
F: 978.532.9406

www.HarmonicDrive.net

Group Companies

Harmonic Drive Systems, Inc.
6-25-3 Minami-Ohi, Shinagawa-ku
Tokyo 141-0013, Japan

Harmonic Drive AG
Hoenbergstrasse, 14, D-6555
Limburg/Lahn Germany

Harmonic Drive is a trademark of Harmonic Drive LLC.

