

Harmonic Drive[®]

DC Servo Driver

HS-360 Series Technical Manual

- Thank you very much for your purchasing our HS-360 series servo driver.
- Be sure to use sufficient safety measures when installing and operating the equipment so as to prevent an accident resulting in a serious physical injury damaged by a malfunction or improper operation.
- Product specifications are subject to change without notice for improvement purposes.
- Keep this manual in a convenient location and refer to it whenever necessary in operating or maintaining the units.
- End user of the driver should have a copy of this manual.

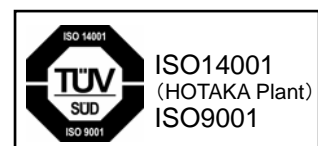



HS Series
Safety guide for handling servomotors



 **Warning** : Indicates a potentially hazardous situation, which, if not avoided, could result in death or serious personal injury.

 **CAUTION** : Indicates a potentially hazardous situation, which, if not avoided, may result in minor or moderate personal injury and/or damage to the

LIMITATION OF APPLICATIONS: This equipment may not be used for the following applications.



- * Space equipment * Aircraft, aeronautic equipment * Nuclear equipment * Amusement equipment, sport equipment, game machines * Vacuum equipment * Automobile, automotive parts * Machine or devices acting directly on the human body * Instruments or devices to transport or carry people * Apparatus or devices used in special environments * Explosion proof equipment

Please consult us, if you intend to use our products in one of the areas mentioned above.





Safety measures are essential to prevent accidents resulting in death, injury or damage of the equipment due to malfunction or

Precautions when using an Actuator

APPLICATION DESIGN: Read the technical manual before designing.





 Caution	<p>Use it in designed conditions.</p> <ul style="list-style-type: none"> ● The actuator must only be used indoors, where the following conditions are provided: - Ambient temperature: 0°C to 40°C - Ambient humidity: 20% to 80%RH (Non-condensation) - Vibration: Max 24.5 m/S² - No contamination by water, oil or foreign matters 	 Caution	<p>Follow exactly the instructions for installation.</p> <ul style="list-style-type: none"> ● Ensure exact alignment of motor shaft center and corresponding center in the application. ● Failure to observe this caution may lead to vibration, resulting in damage of the bearings.
----------------------------------------------------------------------------------------------------	------------------------------------------------------------------------------------------------------------------------------------------------------------------------------------------------------------------------------------------------------------------------------------------------------------------------------------------------------------------------------------------------------------	-----------------------------------------------------------------------------------------------------	----------------------------------------------------------------------------------------------------------------------------------------------------------------------------------------------------------------------------------------------------------------------------------------------------------------------

OPEARTION DESIGN: Read technical manual before operating





 Caution	<p>Do not exceed the allowable torque.</p> <ul style="list-style-type: none"> ● Avoid any torque over the maximum torque from being exerted. ● Be aware that if the arm hits the output shaft when coming into contact with it, the output shaft may become uncontrollable, or the actuator may be damaged. 	 Warning	<p>Never connect cables directly to the outlet or power supply.</p> <ul style="list-style-type: none"> ● The actuator needs to be connected to the dedicated driver to operate. ● Never connect the actuator directly to the commercial power supply or batteries, etc. The actuator may be damaged, resulting in fire.
 Caution	<p>Protect the actuator from impact and shocks.</p> <ul style="list-style-type: none"> ● Do not use a hammer to position the actuator during installation. ● Failure to observe this caution could damage the encoder and may cause uncontrollable operation. 	 Caution	<p>Avoid handling of the actuator by its cables.</p> <ul style="list-style-type: none"> ● Failure to observe this caution may damage the wiring, causing uncontrollable or faulty operation.

Precautions when using a Driver

APPLICATION DESIGN: Read the technical manual before designing.

 Caution	<p>Always use the driver in an environment where the following conditions are provided.</p> <ul style="list-style-type: none"> ● Keep sufficient distance to other devices to let the heat generated by the driver radiate freely * Mount in a vertical position * Ambient temperature: 0°C to 50°C, humidity: less than 95% RH (Non-condensations) * Protect the driver from impact or shock. * No corrosive, inflammable or explosive gas. 	 Caution	<p>Provide sufficient noise suppression and safe grounding.</p> <ul style="list-style-type: none"> ● Always keep signal wire away from noises to avoid vibration and malfunction. * Keep signal and power leads separated. * Keep leads as short as possible. * Ground actuator and driver at one single point, minimum ground resistance class: D. * Do not use a power line filter in the motor circuit.
 Caution	<p>Be careful when turning from the load side.</p> <ul style="list-style-type: none"> ● Be careful with turning the actuator from the output side as this may damage the driver. ● Please consult our sales office, if you intent to use the product in such an application. 	 Caution	<p>Use a fast-response type ground-fault detector designed for PWM inverters.</p> <ul style="list-style-type: none"> ● Do not use a time-delay-type ground-fault detector.

OPEARTION DESIGN: Read technical manual before operating

 Warning	<p>Never change wiring while power is ON.</p> <ul style="list-style-type: none"> ● Be sure to turn OFF power before servicing the product. ● Failure to observe this caution may result in electric shock or personal injury. 	 Warning	<p>Do not touch the terminals right after turning off power.</p> <ul style="list-style-type: none"> ● Otherwise residual electric charges may result in electric shock. ● Provide a housing for the control unit to avoid contact with electric parts.
 Caution	<p>Do not make a voltage resistance test.</p> <ul style="list-style-type: none"> ● Failure to observe this caution may result in damage of the control unit. ● Please consult our sales office, if you intent to use in such an application. 	 Caution	<p>Do not operate a control unit by means of power ON/OFF switching.</p> <ul style="list-style-type: none"> ● Start/stop operation should be performed via input signals. ● Failure to observe this caution may result in deterioration of electronic parts.

Disposal of an actuator, a motor, a control unit or their parts

 Caution	<p>All products or parts have to be disposed of as industrial waste.</p>
------------------------------------------------------------------------------------------------------	--------------------------------------------------------------------------

Contents

Chapter 1	Outline of HS-360 driver	1
1-1	Main features.....	1
1-2	Ordering information of HS-360 driver	2
1-3	Combination with actuator.....	2
1-4	Specification of HS-360 driver	3
1-5	External drawing of HS-360 driver	4
1-6	Names and functions of front panel components	5
Chapter 2	Connector pin layout	7
2-1	T B 1 power supply terminal pin layout	7
2-1	T B 2 actuator cable connection terminal pin layout	7
2-3	C N 1 external I/O connector pin layout.....	7
2-4	C N 2 encoder and limit signal connector pin layout	8
2-5	C N 3 serial port connector pin layout EIA232C-compliant (RS-232C).....	9
Chapter 3	Control input/output	10
3-1	command pulse input (CN1).....	10
3-2	Selecting the command pulse input configuration	11
3-2-1	2-pulse train (FWD and REV pulse train).....	11
3-2-2	1-pulse train (polarity + pulse train).....	11
3-2-3	2-pulse train (2-phase pulses with 90-degree difference).....	11
3-3	Control Input Signals (CN1, CN2).....	12
3-3-1	CN1 input signal connection and functions	12
3-3-2	CN2 input signal connection and functions	14
3-4	Control output Signals (CN1, CN2).....	15
3-4-1	CN1 input signal connection and functions	15
3-4-2	CN2 input signal connection and functions(encoder monitor output)	17
3-5	Encoder input (CN2).....	18
3-6	External connection examples	19
Chapter 4	Installing driver	21
4-1	Receiving Inspection	21
4-2	Notices on handling drivers	22
4-3	Location and installation	23
4-3-1	Environment of location	23
4-3-2	Notices on installation.....	23
4-3-3	Installing	24
4-4	Suppressing noise	24
4-4-1	Devices for grounding	24
4-4-2	Installing noise filters	25
4-4-3	Instructions for cabling	26

4-5	Connecting power cables.....	27
4-5-1	Instructions for power supply.....	27
4-5-2	Power cables and ground wires.....	27
4-5-3	Connecting power cables.....	28
4-5-4	Isolation transformer (sold optionally).....	28
4-5-5	Protecting the power line.....	29
4-6	Connecting the ground wire.....	29
4-7	Connecting the actuator cable.....	29
4-8	Connecting cables for the encoder and the I/O.....	30
4-8-1	Preparing the encoder cable and the I/ O cable.....	30
4-8-2	Pin layout of external I/O connector (CN1).....	30
4-8-3	Pin layout of encoder connector (CN2).....	30
4-9	Power on and off sequences.....	31
Chapter 5	Operations.....	32
5-1	Trial run.....	32
5-2	Usual operation.....	34
5-2-1	Notices for daily operations.....	34
5-2-2	Daily maintenance.....	35
Chapter 6	Operating the display panel.....	36
6-1	Outline of modes.....	36
6-2	Changing a mode.....	36
6-3	Monitor mode display details.....	37
6-3-1	Servo state display.....	37
6-3-2	Alarms.....	37
6-3-3	Resetting the alarm.....	37
6-3-4	Displaying the alarm history.....	37
6-3-5	Clearing the alarm history.....	37
6-4	Outline of parameter setup mode.....	38
6-4-1	Operating parameter setup mode.....	38
6-5	Outline of numeric monitor mode.....	39
6-5-1	Numeric monitor list.....	39
6-5-2	Displaying numeric monitor data.....	39
6-5-3	Clearing the torque peak.....	40
6-5-4	Displaying stop cause.....	40
6-5-5	Displaying control state.....	40
6-5-6	Displaying I/O state.....	40
6-6	JOG operation mode.....	41
6-6-1	JOG operations procedure.....	41
6-7	Displaying and setting data of high- and low-order digits.....	43
Chapter 7	Parameter details.....	44
7-1	Default setup parameters.....	44
7-2	Parameter details.....	45

Chapter 8	Protective functions	59
8-1	Outline of protective functions	59
8-2	Details of protective functions.....	60
Chapter 9	Troubleshooting procedure and action	67
9-1	No rotation of actuator	67
9-2	Unstable rotation of actuator.....	68
9-3	Poor positioning accuracy	70
INDEX.....		72

Memo

Chapter 1 Outline of HS-360 drivers

Each HS-360 driver is available exclusively for an RH/RHS/RFS/LA/LAH Series actuator, consisting of a combined system of a small-sized precision control reduction gear Harmonic drive® and small DC servomotor.

HS-360 drivers have many features to exhibit fully the characteristics of each actuator.

1-1 Main features

● Easy parameter setting

Parameters have been set to match the driver with the actuator you have ordered. Users do not need to make any settings for the actuator, except in case of using particularly specific parameters.

For this driver, the parameters to optimize the higher-level system and controllability can easily be set or changed by viewing "Parameter mode" the seven-segment LED display.

● Substantial monitoring functions

The status of operation can be continuously displayed as either "Status display mode" or "Numeric monitor mode", and the settings of the desired parameters can be monitored. Information of "Command", "Feedback", and "Error counter", specifically important for the servo system, can be monitored.

Up to eight previous events of "Alarm history" can be shown, and also the process diagnosing a problem can be viewed.

● Easy test operation

In "JOG mode", operating buttons on the panel enables "JOG" operation.

● Electronic gear suitable for mechanical system

The electronic gear "Command pulse input factor" function adjusts commands to the feed pitch or angle of the driven mechanism.

● Three types of input signals for position commands

Three types of input signals for the position command are selectable: "Two-pulse train", "Single-pulse train", and "Two-phase pulse train".

1-2 Ordering information of HS-360 driver

The HS-360 driver model indication and the mark shown in this manual are as follows:

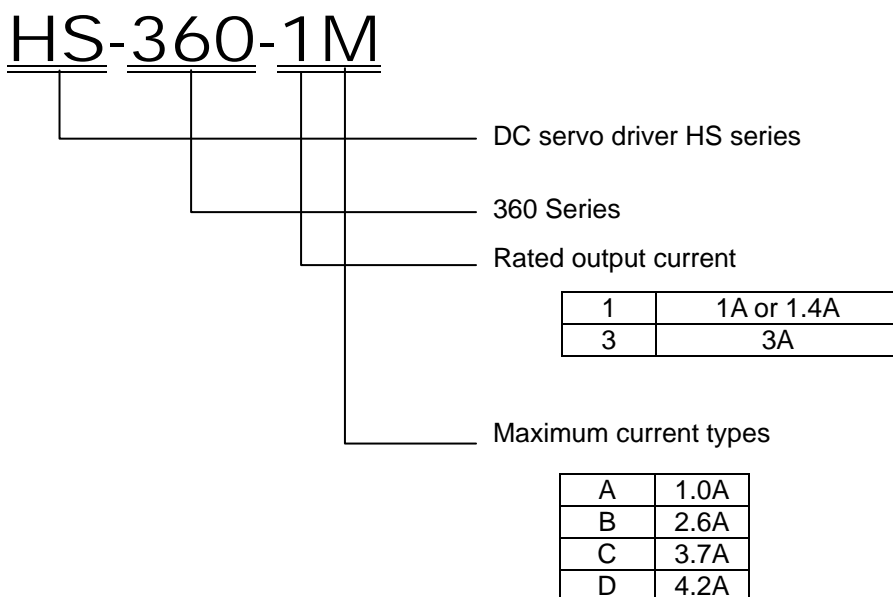

Be sure to use a power supply voltage with the specified voltage. Otherwise, damage of driver or fire may occur.

1-3. Combinations with actuator

The following table lists the actuators that can be combined with HS-360 drivers:

Driver type	HS-360-1A	HS-360-1B	HS-360-1C	HS-360-1D	HS-360-3
Combined Actuator type	RH-5A-8802 RH-5A-5502 RH-5A-4402	RH-8D-6006 RH-8D-3006	RH-11D-6001 RH-11D-3001	RH-14D-6002 RH-14D-3002	RHS-20-6007 RHS-20-3007 RHS-20-6012 RHS-20-3012 RHS-25-6012 RHS-25-3012
	(Linear Actuator) LA-30B-10-F-L LA-32-30-F-L LAH-46-1002-F-L LAH-46-3002-F-L LNP-XXX-XX-R24A-XXX-DC(AL)		RHS-14-6003 RHS-14-3003	RHS-17-6006 RHS-17-3006	RFS-20-6007 RFS-20-3007 RFS-20-6012 RFS-20-3012 RFS-25-6012 RFS-25-3012

The 1000P/R line driver specification is recommended as the encoder resolution of DC servo actuators. The encoder resolution for the RH-5A and linear series will be, however, the line driver specification of 360P/R or 500P/R.



Signal exchanges of the HS-360 series between the driver and encoder are only with a line driver. Use at the open collector is not feasible.

1-4 Specification of HS-360 drivers

Item	Model	HS-360-1A	HS-360-1B	HS-360-1B	HS-360-1D	HS-360-3
Rated output current (rms) Note 1		1.0A	1.4A			3.2A
Maximum output current (rms) Note 2		1.0A	2.6A	3.7A	4.2A	10A
Operating current	Single-phase AC100V±10% 50/60Hz					
Controlling	PWM control (control element: IPM), switching frequency: 12.5kHz					
Applicable position sensor	Incremental encoder (Phase-A, B, Z, output) Line driver					
Structure/installation	Self-cooling, Base mount (installing on the surface)					
Control function	Positioning control by pulse train input					
Maximum input pulse frequency	400kp/s (Max)(line driver) 200kp/s(Max)(open collector)					
Command pulse input configuration	1 pulse, 2 pulse, 2-phase pulse					
Control input signal	Servo on, Alarm reset, Error counter reset, Forward (FWD) inhibit, Reverse (REV) inhibit					
Control output signal	Ready, Alarm, In-position					
Encoder monitor output	Phase Z open collector output. Phase-A, B, Z-voltage output (+5V).					
Serial interface	EIA232C (RS232C) dedicated cable connection					
Monitor	Operational status, alarm history, I/O, and parameters can be monitored. The operation waveform can also be monitored with using the dedicated software.					
Protective functions	Memory failure, overload, encoder failure, regeneration failure, system failure, over-current, excessive error, IPM failure, over-speed					
Built-in circuit	Dynamic brake circuit, regeneration unit connection terminal					Note 3
Built-in functions	Operated manually (JOG running, alarm history clear, etc.)					
Ambient conditions	Service temperature: 0 to +50°C Service humidity: 90%RH or less (non-condensation)		Storage temperature: -20 to +85°C Storage humidity: 90%RH or less (non-condensation)		Vibration resistance: 4.9 m/s ² (10 to 55Hz) Impact resistance: 98m/s ²	
Mass	Atmosphere: Must not contain any metal powder, dust, oil moisture, or corrosive gas.					
	0.8kg					

Note: The parameters have been factory-set in this product so that it operates as suitable for operation of the actuator (i.e., motor) with which it combines. Do not use the product for any actuator other than the preset one.

Note 1: Indicates the continuous output current from the driver.

This value is restricted, depending on the combination with the actuator.

Note 2: The maximum output current indicates the maximum momentary current.

This value is restricted, depending on the combination with the actuator.

Note 3: The regeneration unit is not required for the object actuator.

1-5 External drawing of the HA-360 drivers

The external drawing is shown below:

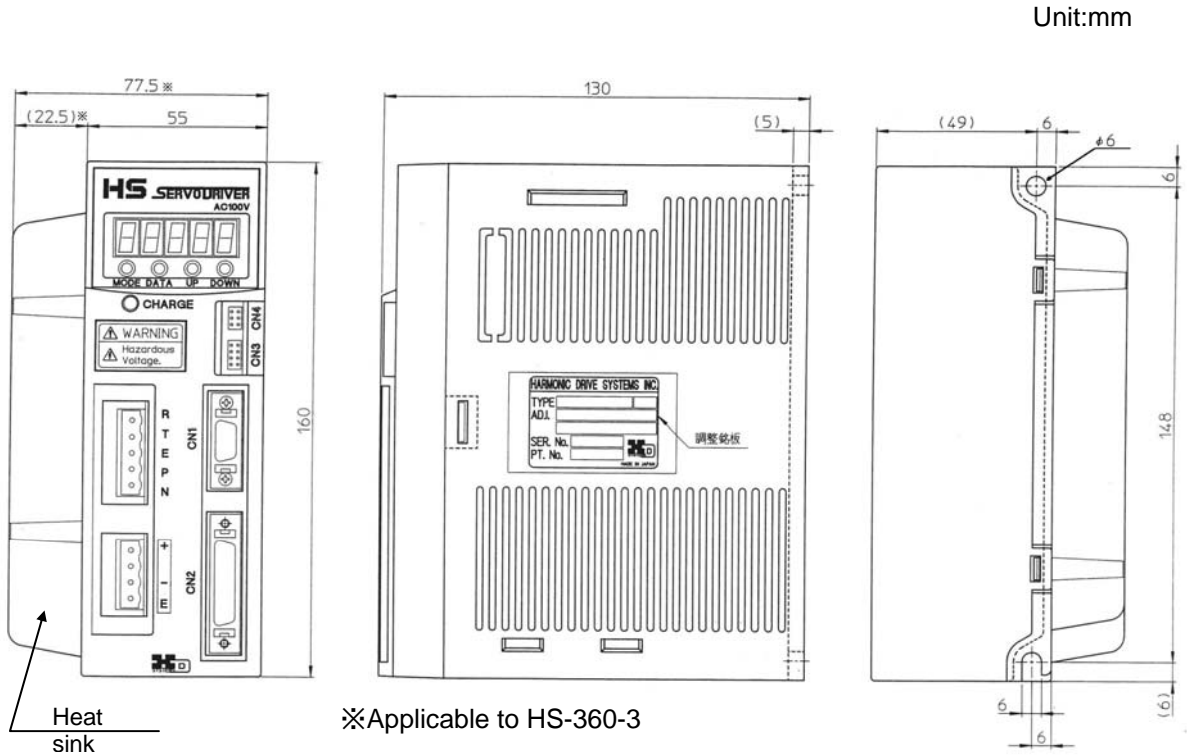

● External drawing of the DC reactor 15mH

The following illustrations show the shape and dimensions of a DC reactor.

※A DC reactor of 15mH needs to be connected between the driver and actuator when the HS-360-1A is used. A DC reactor of 15mH will be supplied with the driver as an accessory.

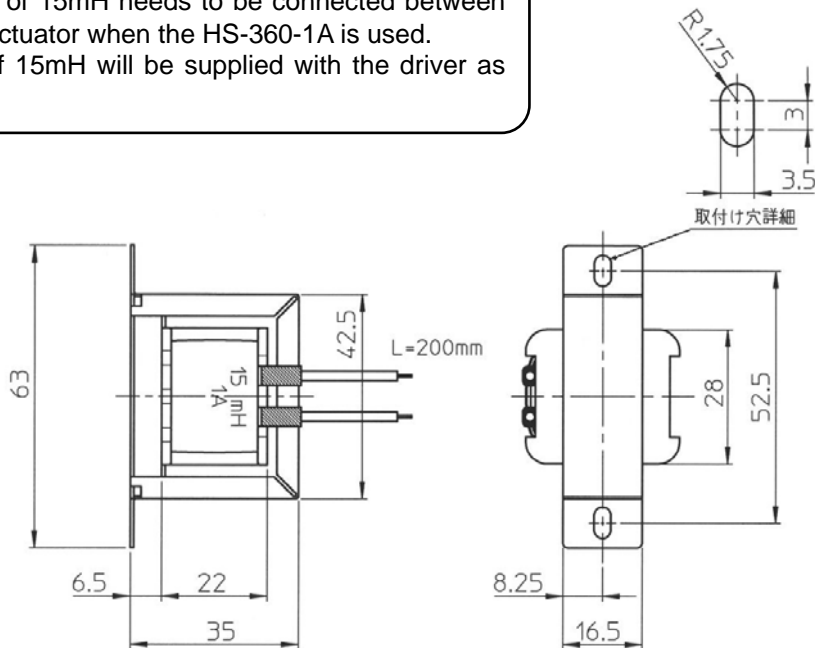

1-6 Names and functions of front panel components

● Display panel component names

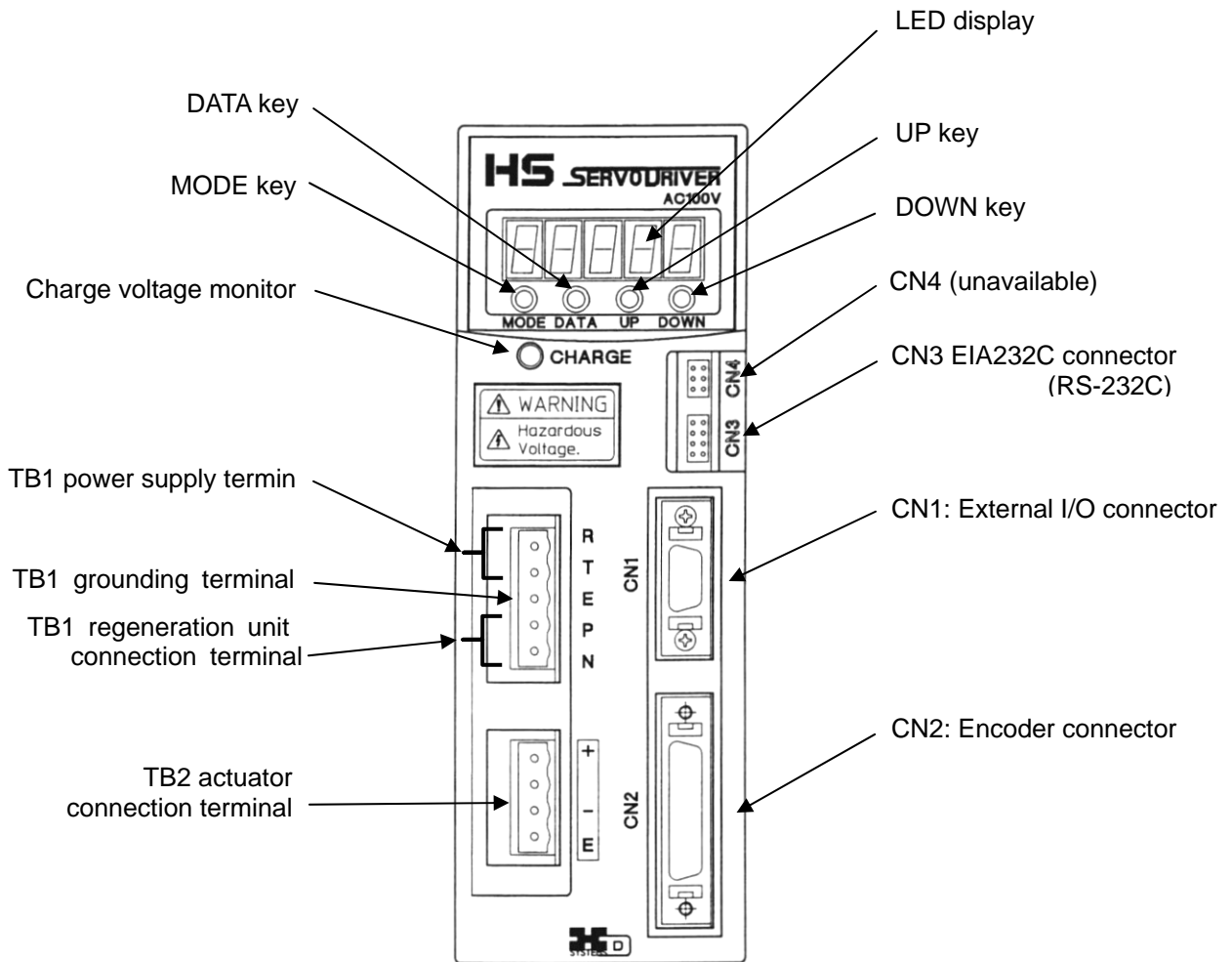

● Functions of display panel component

◆ LED display

Indicates operating states of the HS-360 driver, parameters, alarms, by a 5-digit 7 segment-LED.

◆ [MODE], [DATA], [UP], and [DOWN] keys

Are used for changing indications, setting and tuning functional parameter values, and manual JOG operation of actuators.

◆ Charge voltage monitor

Indicate the monitored voltage of the power supply terminal. While the LED is on, do not touch the terminal because it is at high voltage.

◆ CN1: external I/O connector

Used to exchange control signals with the high-level controller.

- ◆ **CN2: encoder connector**
Used to connect the position detection encoder cable of the actuator or the cable of the FWD/REV inhibit limit sensor.
(Enables the encoder signal output to be monitored.)
- ◆ **CN3: EIA232C (RS232C) serial port connector**
Used for connection with a personal computer. Parameters can be set or changed, or the status can be monitored through this connector. (The dedicated communication cable (sold optionally) and software are necessary.)
- ◆ **CN4: Unavailable**
Do not attempt to use this.
- ◆ **TB1: power supply terminal (R, T)**
Power supply connection AC 100 V power supply terminals.
Be sure to use only the voltage not shown on the driver.
- ◆ **TB1: grounding terminal (E)**
Used for grounding. To prevent electric shock, be sure to connect the ground wire to the ground.
- ◆ **TB1: external regeneration unit connection terminal (P, N)**
If the start/stop frequency is high because the moment of inertia of the load is large and the internal regeneration capacity is insufficient, a regeneration unit should be connected to this terminal.
- ◆ **TB2: actuator connection terminal (+, -, E)**
Used to connect the actuator lead wire. Associate the actuator colors and HS-360 driver symbols with the proper counterparts. If the association contains an error, the driver or actuator may break.

Chapter 2 Connector pin layouts

2-1 TB1 power supply terminal pin layout

Pin No.	Signal name	Description
1	R	Power supply terminal AC 100V, 50/60Hz
2	T	
3	E	Grounding terminal
4	P	Regeneration unit connection terminal
5	N	

(1) Applicable terminal type for cable: Plug: 231-305/026-000 (manufacturer: WAGO)

(2) Applicable electric wire for cable: AWG14 (2.0mm²)



Warning

Be sure to use a power supply voltage with the specified voltage.

Otherwise, the driver may break, or fire may occur.



Warning

P-N is a terminal to which the unit's regeneration connector should be connected. If another terminal is connected here, the driver may break, or fire may occur.

2-2 TB2 actuator cable connection terminal pin layout

Pin No.	Signal name	Description
1	+	Actuator(+)connection terminal
2	NC	Non-Terminating Terminal
3	-	Actuator (-) connection terminal
4	E	Grounding terminal

(1) Applicable terminal type for cable: Plug: 231-304/026-000 (manufacturer: WAGO)

(2) Applicable electric wire for cable: AWG16 (1.5mm²)

(3) Maximum wiring length: 10m

2-3 CN1 external I/O connector pin layout

	Pin No.	Signal name	Description
Pulse train	1	FWD+	FWD operation pulse (+)
	2	FWD-	FWD operation pulse (-)
	3	REV+	REV operation pulse (+)
	4	REV-	REV operation pulse (-)
Control input	5	ENABLE	Servo On
	6	ALM-RST	Alarm Reset
	7	CLEAR	Error Counter Reset
	8	IN-COM	Input Signal Common
Control output	9	READY	Ready
	10	ALARM	Alarm Output
	11	IN-POS	In-Position
	12	Z-IZ	Encoder Phase-Z
	13	OUT-COM	Output Signal Common
	14	FG	Frame Ground

Refer to Chapter 3 for details.

(1) Applicable terminal type for cable: Cover: 10314-52F0-008

Plug: 10114-3000VE (manufacturer: 3M)

(2) Applicable electric wire for cable: 0.2mm² or more, shielded wire

(3) Maximum wiring length: 3 m or less

2-4 CN2 encoder and limit signal connector pin layout

	Pin No.	Signal name	Description		
Actuator encoder input	1	PG-Vcc	Encoder +5V Power Supply	+5V power to the encoder. Supplied from the inside of the servo amplifier.	
	2				
	3				
	4				
	5	PG-0V	Encoder Power Common	Common terminal for the +5V power to the encoder.	
	6				
	7				
	8				
	9	A	Phase-A Input	Input terminal for the encoder signals from the actuator (line receiver input).	
	10	\bar{A}	Phase-A Reversal Input		
	11	B	Phase-B Input		
	12	\bar{B}	Phase-B Reversal Input		
	13	Z	Phase-Z Input		
	14	\bar{Z}	Phase-Z Reversal Input		
	15	NC	Non Terminating Terminal	Note 3	
	16	NC			
	17	NC			
	18	NC			
	19	NC			
	20	NC			
Monitor Output	21	EPG-Vcc	Encoder External (+5V) Supply Power	Used to supply the +5V power from the encoder from the outside. Note 2	
	22	EPG-0V	Encoder External Supply Power Common	Common terminal to supply the +5V power from the outside. Note 2	
	23	MON-Vcc	+5V Encoder Monitor Power	Used to supply the +5V encoder monitor pulse from the outline.	
	24	MON-0V	Encoder Monitor Power Common	+5V power common terminal for encoder monitor pulse output.	
	25	MON-A	Encoder Monitor Phase-A Output	Encoder monitor pulse output (open collector output).	
	26	MON-B	Encoder Monitor Phase-B Output		
	27	MON-Z	Encoder Monitor Phase-Z Output		
	28	NC	Non-Terminating Terminal	Note 3	
	Limit input	29	LMT-Vcc	LMT Signal Power	Used to supply the +24V limit input power from the outside.
		30	NC	Non-Terminating Terminal	Note 3
31		FWD-LMT	FWD Inhibit	Terminating terminal of FWD side rotation limit switch.	
32		NC	Non-Terminating Terminal	Note 3	
33		REV-LMT	LEV Inhibit	Terminating terminal of REV side rotation limit switch.	
34		NC	Non-Terminating Terminal	Note 3	
FG	35	FG	Frame Ground	Connected to the frame and power supply grounding terminal.	
	36				

Note 1: Connect the shielded wire to the connector's FG terminal or ground plate.

Note 2: When the internal encoder supply power voltage drops and it does not operate normally, the external signal is supplied through this terminal. Use of this terminal requires changing the driver's internal switch settings. For details of its use, consult with a business office of Harmonic Drive Systems.

Note 3: Unavailable. Do not attempt to use this terminal

(1) Applicable terminal type for cable: Cover: 10336-52F0-008

Plug: 10136-3000VE (manufacturer: 3M)

(2) Applicable electric wire for cable: 0.2mm² or more shielded twisted pair cable

(3) Maximum wiring length: 10 m or less

2-5 CN3 serial port connector pin EIA232C-compliant (RS-232C)

C N 3 EIA232C (RS232C)

Pin No.	Signal name	Description
1	FG	Frame Ground
2	RXD	Receive Data
3	TXD	Transmit Data
4	DTR	Data Terminal Ready
5	GND	Signal Ground
6	DSR	Data Set Ready
7	RTS	Request To Send
8	CTS	Request To Send

※ Connect the communication cable shielded wire to the Pin 1 [FG: Frame Ground].

(1) Applicable terminal type for cable: (driver)

Socket terminal: DF11-2428-SCF (manufacturer: Hirose)

Socket terminal: DF11-2428-SCF (manufacturer: Hirose)

(2) Applicable electric wire for cable: 0.2mm² shielded electric wire

(3) Maximum wiring length: 10m or less

(4) Configure the communication cables

Configure the communication cables according to the following figure:

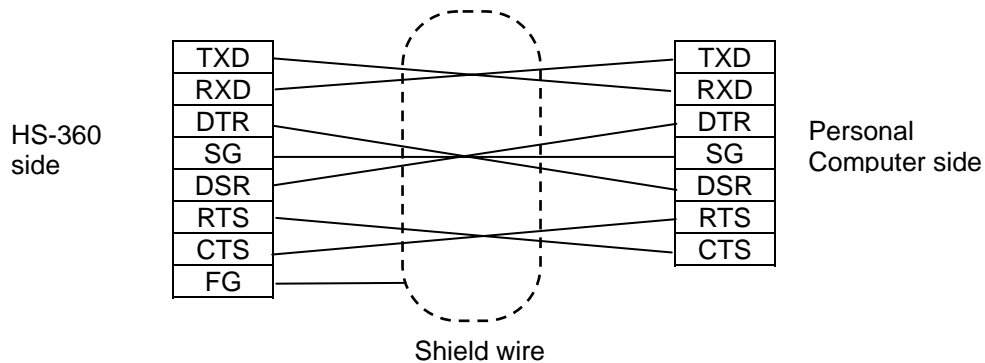

● Personal computer monitoring

On a personal computer, various items of monitored information can be displayed, parameters can be read and written, and the operational-status waveform can be displayed.

Personal computer software:

Software product name: PSF-520

Available in the Windows 2000 or XP environment

Sold optionally:

EIA232C (RS-232C) communication cable Model: HDM-RS232C



Caution

CN4 is an unavailable connector.

Attempting to use CN4 may cause the driver to break.

Chapter 3 Control input/output

3-1 Command pulse input (CN1)

This inputs the pulse train input to FWD+, FWD-, REV+, and REV-. This section shows a connection with a line driver command and that with an open collector command. The standard input current shall be 20mA, while the maximum input current shall be 30mA.

◆ Connection with a line driver command

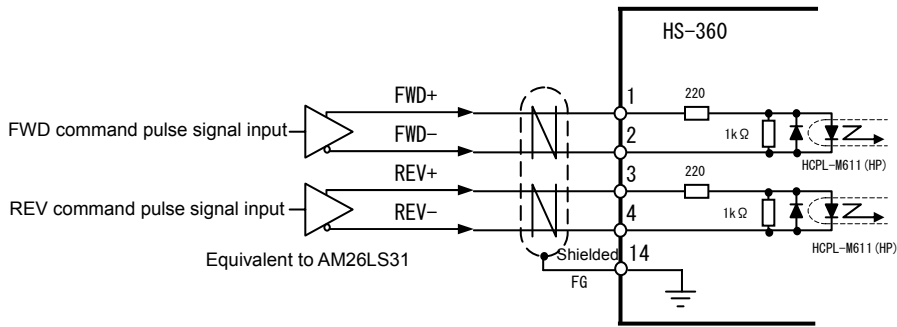

◆ Connection with an open collector command

● For +5V external power

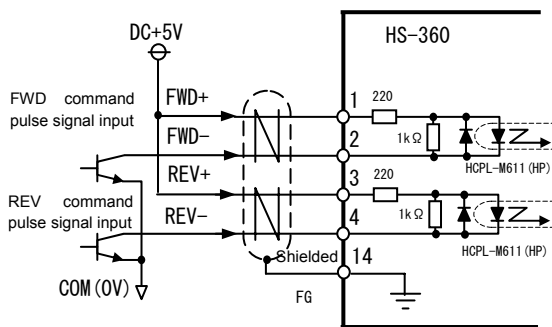

● For +24V external power

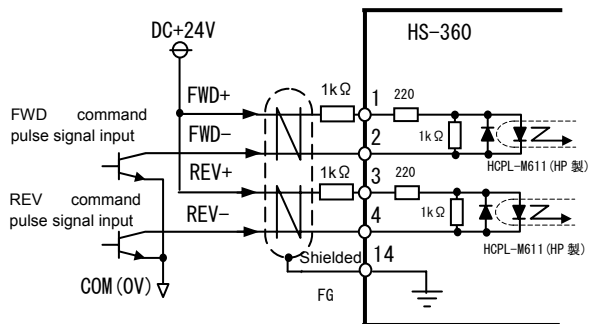

If the +24V supply voltage is used with an open collector command, the connection must be made in a different way.

For the supply voltage, "+5V" is the standard. For "+24V", add a 1kΩ resistor serially to the connection. If the 1kΩ resistor is omitted, the driver may break.



Encoder signal processing

The HS-360 driver executes the internal feedback process with a signal that is obtained by multiplying the encoder feedback signal by 4.

By default, the amount of movement is obtained by multiplying the encoder resolution by 4 relative to the command pulse input count.

3-2 Selecting the command pulse input configuration

Two ports of CN1-1&2 and CN1-3&4 are available for pulse input signals. Each of the signals input through these two ports has one of three pulse input configurations.

◆ Setting a command configuration

[Parameter setup mode]→ [31: selecting the pulse input configuration]

3-2-1 2-pulse train (FWD and REV pulse train)

As shown in the figure, “FWD commands” are input through the “FWD” port, while “REV commands” through the “REV” port. While the input is in progress, keep the other port “off”. This is also called the “FWD and REV pulse train method”, and is the default setting.

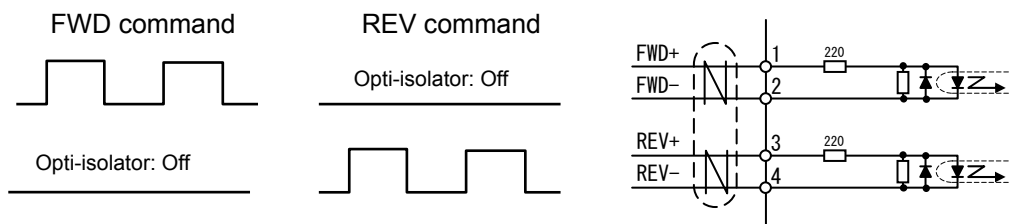



Caution If the other port is turned “on” while a command pulse is being input through the port, the command pulse will be disabled when being turned on.

3-2-2 1-pulse train (polarity + pulse train)

One pair of terminals is assigned dedicatedly for command pulse train, and the other is assigned to a sign for rotary direction. Position commands are input in the “FWD” port pair only and the “REV” port pair accepts the sign of rotary direction, as shown in the figure below. [Off] or [Low level] state is for the FWD command and [On] or [High] level is for the REV command.

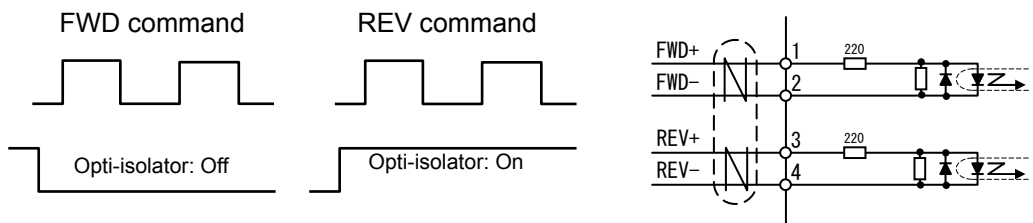

3-2-3 2-pulse train (A-B phase pulses with 90-degree difference)

Both port pairs receive the command pulse trains that have a 90-electronic-degree difference relative to each other as shown in the figure below. For the “FWD command”, the pulse train to the “FWD” ports advances 90 degrees from the REV port train. For the “REV command”, the “REV” port train advances from the FWD port train.

Actuator encoder monitor signals are output according to this method.

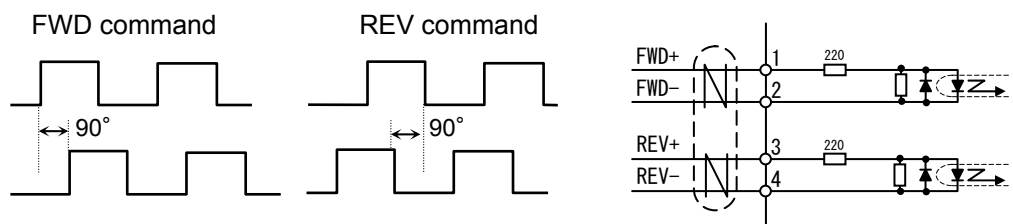

● **Multiplication of command**

When the command configuration is a [2-phase pulse] type, it is possible to multiply the command pulse train by 2 or 4 for the command pulse train to an actuator.

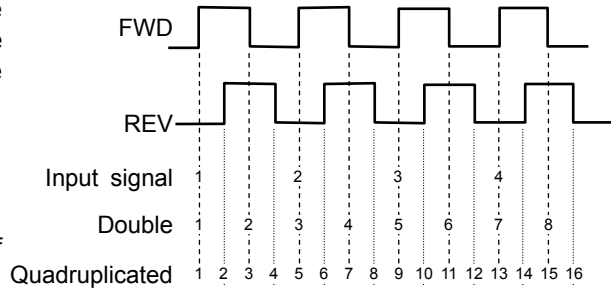

◆ **Setting**

[Parameter setup mode] → [42: multiplication of 2-phase pulse]

3-3 Control Input Signals (CN1, CN2)

This section shows connection examples and details of the functions with respect to the CN1 input signals.

3-3-1 CN1 input signal connection and functions

The input signals are ENABLE, ALM-RST, and CLEAR.

The input circuit power supply is at DC 24V. (The input current is at approximately 10mA per circuit.) Prepare it separately.

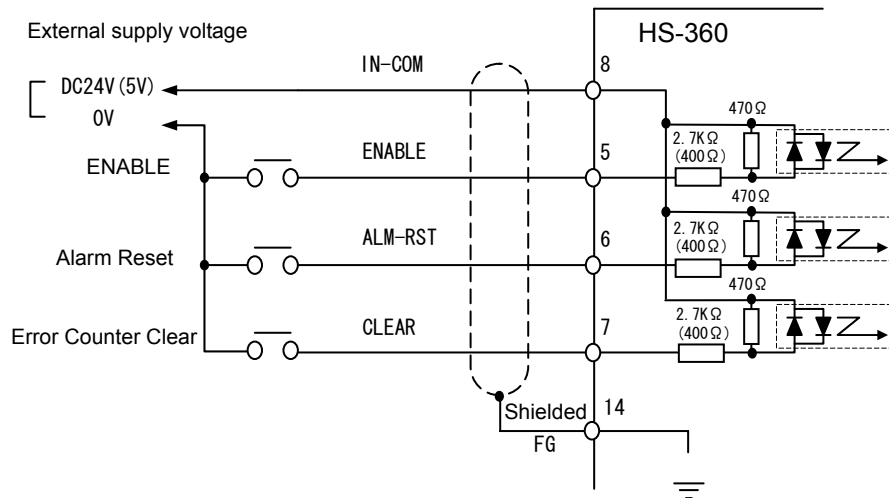

- ※ Values in () are the values when 5V power supply is impressed. External power supply of 5V is needed.
- ※ The voltage is set to 24V during preshipment inspection. Set all “1” to “4” on the DIP switch (DS1) on the printed circuit board in the driver to “ON” when 5V power supply is impressed to the input circuit.
- ※ Select only 24V or 5V as voltage for external power supply. (Single power supply voltage)

DIP switch state	Control power voltage
All ON	5V
All OFF	24V

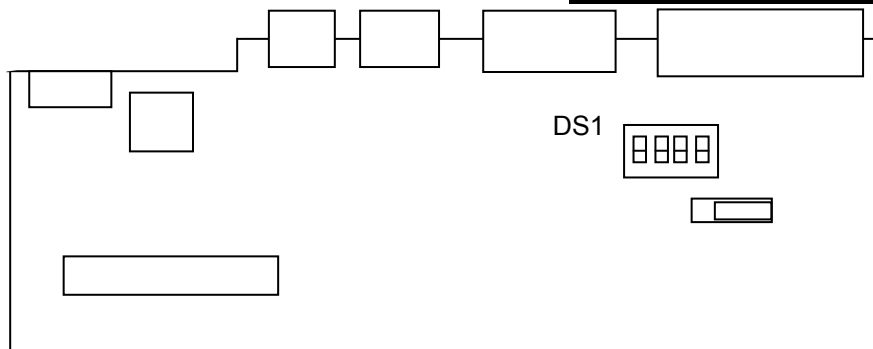

Configuration of DIP switch DS1 on printed circuit board

CN1-5 Servo on: ENABLE**◆ Functions**

- (1) This signal turns on/off the driver circuit of the HS-360 driver.
When this input is on, the driver servo goes on, causing the driver to be ready. When it is off, the servo goes off, causing the servo to be free, or the dynamic brake to be active.
- (2) The dynamic brake on/off selection can be made by selecting [Parameter setup mode] → [46: Dynamic brake on/off].
- (3) The logic can be changed by selecting [Parameter setup mode] → [38: Input pin logic]. The default is 0 (CLOSE), and the signal is meaningful.
- (4) If [Parameter setup mode] is selected and 1 is selected in [41: CLEAR signal functions], the error counter is also cleared and the error pulse count is set to 0.

◆ Connection

- (1) For the input circuit power supply, prepare DC 24V separately.
- (2) The input current is at approximately 10mA per circuit.

CN1-6 alarm reset: ALM-RST**◆ Functions**

- (1) When an alarm occurs
The alarm is cleared, and the driver is made ready. The edge is used for detection. If an unclearable alarm occurs, turn off the power once. In this case, turn the power on again after removing the cause of the alarm.
- (2) The logic can be changed by selecting [Parameter setup mode] → [38: Input pin logic]. The default is 0 (CLOSE falling edge), and the signal is meaningful.
- (3) If [Parameter setup mode] is selected and 1 is selected in [41: CLEAR signal functions], the error counter is also cleared and the error pulse count is set to 0.

□ Connection

- (1) For the input circuit power supply, prepare DC 24V separately.
- (2) The input current is at approximately 10mA per circuit.

CN1-7 error counter clear: CLEAR**◆ Functions**

- (1) Clear the error counter, and set the error pulse count to 0.
- (2) The logic can be changed by selecting [Parameter setup mode] → [38: Input pin logic]. The default is 0 (CLOSE falling edge), and the signal is meaningful.
- (3) If [Parameter mode] is selected and 0 is selected in [41: CLEAR signal functions], this input signal will be enabled. If 1 is selected there, it will be disabled.

◆ Connection

- (1) For the input circuit power supply, prepare DC 24V separately.
- (2) The input current is at approximately 10mA per circuit.

CN1-8 input signal common: IN-COM

◆ **Function**

This is a common signal to “CN1-5, -6, and -7”, and supplies power form the outside for input signals.

◆ **Connection**

The externally supplied voltage for input signals is “+24V”.

3-3-2 CN2 input signal connection and functions

FWD-LMT and REV-LMT are available for input signals.

No running torque is generated at the terminal through which this signal is being input.

For the input circuit power, prepare DC 24V separately (the current consumption is approximately 10mA per circuit).

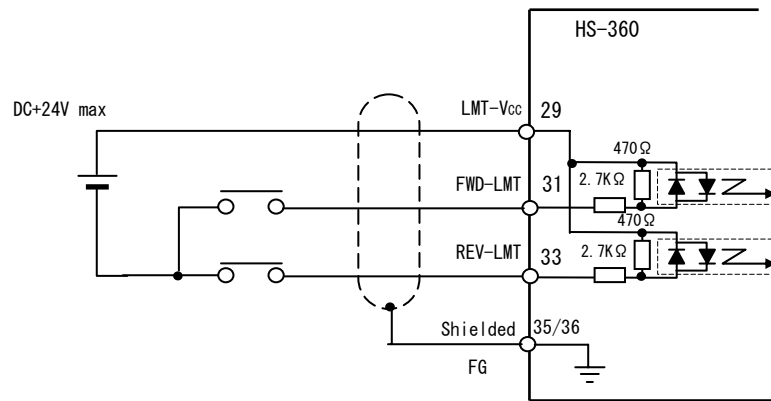

CN2-31 FWD inhibit: FWD-LMT

CN2-33 REV inhibit: REV-LMT

◆ **Functions**

- (1) FWD (or REV) inhibit: The actuator does not generate any forward (or reverse) torque while the input signal is being generated. If both of the input signals are generated, the actuator generates neither forward nor reverse torque. The inputs may be used to limit the motion range between limit sensors.
- (2) All pulses that are input to the detected portion during limit sensor detection are ignored.
- (3) The logic can be changed by selecting [Parameter setup mode] → [38: Input pin logic]. The default is 0. When the input signal causes the opti-isolator to be on, the limit function works.

◆ **Connection**

- (1) For the input circuit power supply, prepare DC 24V separately.
- (2) The input current is at approximately 10mA per circuit.

CN2-29 LMT signal power: LMT-Vcc

◆ **Function**

FWD-LMT and REV-LMT are power supply terminals.

◆ **Connection**

Connect the 24VDC external power.

3-4 Control output signals (CN1, CN2)

3-4-1 CN1 output signal connection and functions

READY, ALARM, IN-POS, and Z-IZ are available as control output signals.

Prepare the output circuit power supply separately. It can also be used in common with the input circuit power supply. In this case, to obtain the power supply capacity, add the output power supply capacity to the input power supply capacity.

The maximum control output applied voltage is 30V. The maximum allowable output current is 100mA per circuit, except that, for the Z-IZ signal, it shall be 30mA per circuit.

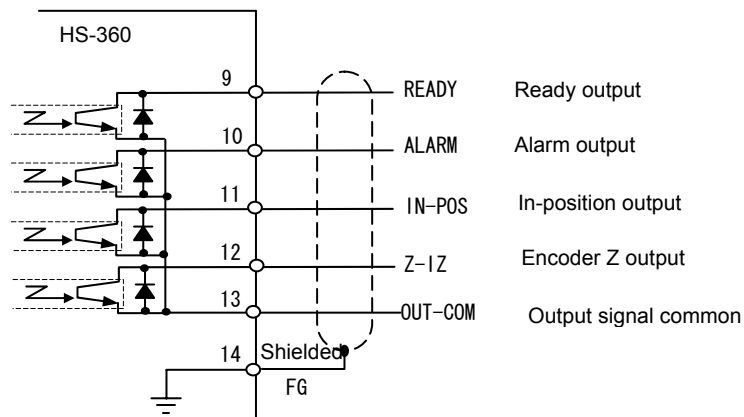

CN1-13 output signal common: OUT-COM

◆ Function

This is a common terminal for the READY, ALARM, IN-POS, and Z-IZ output signals.

CN1-9 ready output: READY

◆ Function

- (1) When a servo on input when the driver is normal, this signal is output, indicating that the actuator is operating normally.
When an alarm occurs, this signal remains off.
- (2) The logic can be changed by selecting [Parameter setup mode] → [39: Output pin logic]. The default is 0. When the driver is ready for normal operation, the transistor goes on.

◆ Connection

Design the receiving circuit so that the following are satisfied:

Voltage: DC 30V or less

Current: 100mA or less

CN1-10 alarm output: ALARM**◆ Function**

- (1) This signal is output when the driver detects a failure.
- (2) The logic can be changed by selecting [Parameter setup mode] → [39: Output pin logic]. The default is 1. When the driver is operating normally, the transistor goes on. When a failure is detected, it goes off.

◆ Connection

Design the receiving circuit so that the following are satisfied:

Voltage: DC 30V or less

Current: 100mA or less

CN1-11 In-position output: IN-POS**◆ Function**

- (1) This signal is output when the error counter value reaches or goes below the setting made in [Parameter setup mode] → [01: In-position range]. The higher-level system uses it for an in-position confirmation signal, for example.
- (2) The logic can be changed by selecting [Parameter setup mode] → [39: Input pin logic]. The default is 0. When the amount of accumulated pulses for the error counter is equal to or less than the in-position range setting, the output transistor goes on.

◆ Connection

Design the receiving circuit so that the following are satisfied:

Voltage: DC 30V or less

Current: 100mA or less

CN1-12 encoder Phase-Z output: Z-IZ**◆ Function**

This outputs the encoder Phase-Z pulse signal. One pulse is output during one revolution of the motor. The Harmonic Driver Systems actuator outputs the same pulse count as the reduction ratio during one revolution of the output spindle. This signal is useful, for example, to recognize the accurate position of the origin together with the origin sensor signal of the automatic mechanism.

This signal output is enabled when the motor revolution speed is 200r/min or less.

◆ Connection

Design the receiving circuit so that the following are satisfied:

Voltage: DC 30V or less

Current: 30mA or less



When monitoring the encoder Phase-Z pulse, operate the motor at a revolution speed of 200r/min or less.

This signal is no longer output when the motor revolution speed exceeds 200r/min. When monitoring this signal, be sure to operate the motor at a revolution speed of 200r/min or less.

3-4-2 CN2 output signal connection and functions (encoder monitor output)

CN2-23 encoder monitor +5V power: MON-Vcc

- ◆ **Function**
This is a power supply terminal for MON-A, -B, and -Z.
- ◆ **Connection**
Connect the DC 5V external power.

CN2-24 encoder monitor power common: MON-COM

- ◆ **Function**
This is a common terminal for the MON-A, -B, and -Z output signals.

CN2-25 encoder monitor Phase-A output: MON-A

CN2-26 encoder monitor Phase-B output: MON-B

CN2-27 encoder monitor Phase-Z output: MON-Z

- ◆ **Function**
To output the Phase-A, -B, or -Z pulse with the appropriate voltage to indicate the monitored result of the encoder.
Prepare DC 5V for the output circuit power separately.

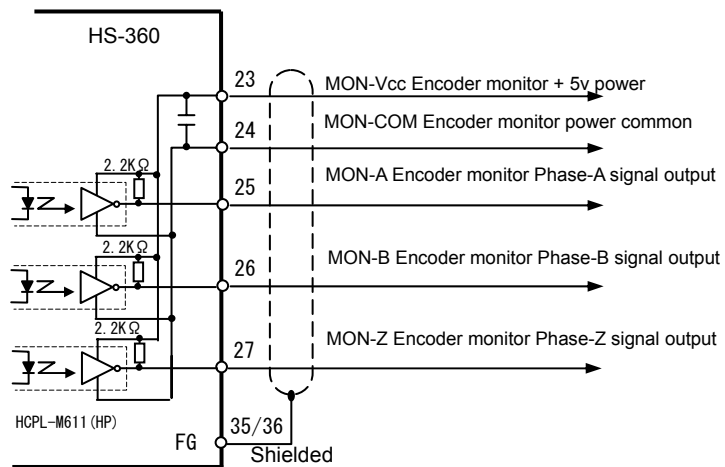

- ◆ **Connection**
 - (1) The external supply voltage is required. The power supply voltage is DC 5V.
 - (2) The monitor signal is the voltage output.



The maximum allowable supply voltage is 5V.

The maximum allowable supply voltage is 5V.
Connection of any voltage exceeding 5V may break the driver.

3-5 Encoder input (CN2)

- ◆ **Function**
Connect this with the DC servo actuator encoder.

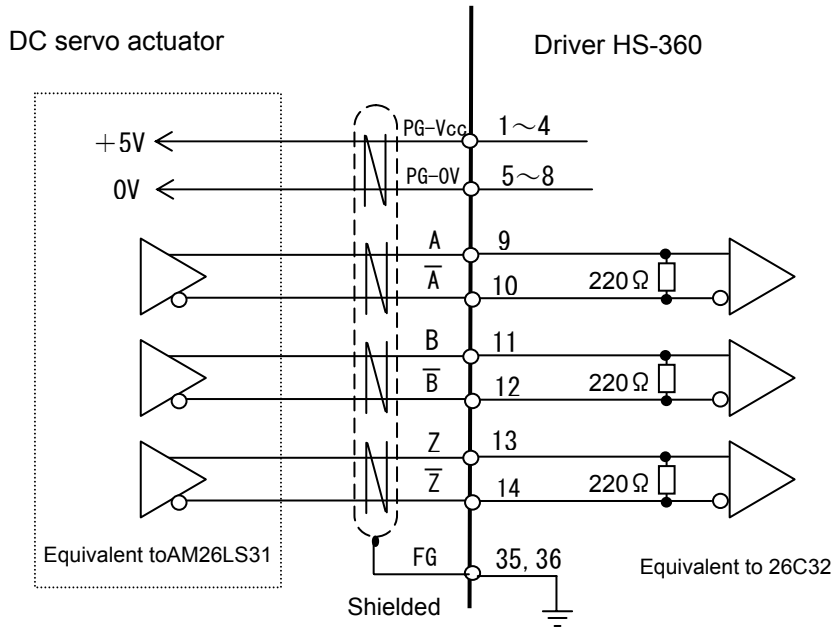

- ◆ **Connection**
- (1) Connect the shielded wire securely to CN1-35 and 36.



Only a line driver can be connected to the encoder.

Encoder output such as an open collector or TTL cannot be connected.

3-6 External connection examples

- ◆ The following is an external connection example where the pulse output configuration is a line driver.
- ◆ The command configuration is 2-pulse train.

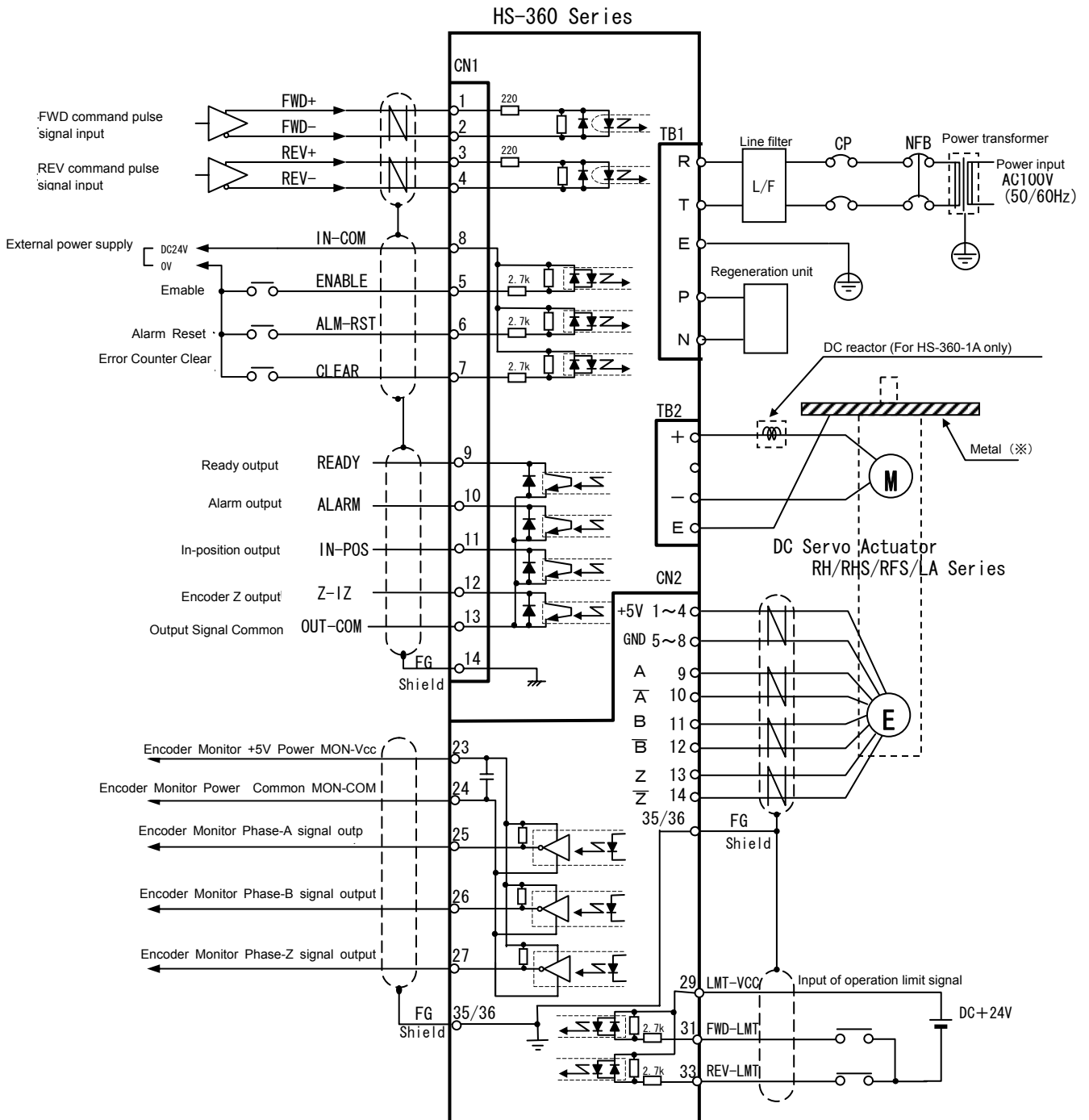

Note: The required voltage may be AC 100V, depending on the combination with the actuator. Be sure to use the product with the predetermined voltage

※ : Be certain to connect the mounting part of the actuator and “E” of TB2 by wire. An encoder error (Alarm 02) may result if wire is not installed.

- ◆ The following is an external connection example where the pulse output configuration is open collector.
- ◆ The command configuration is 2-pulse train.

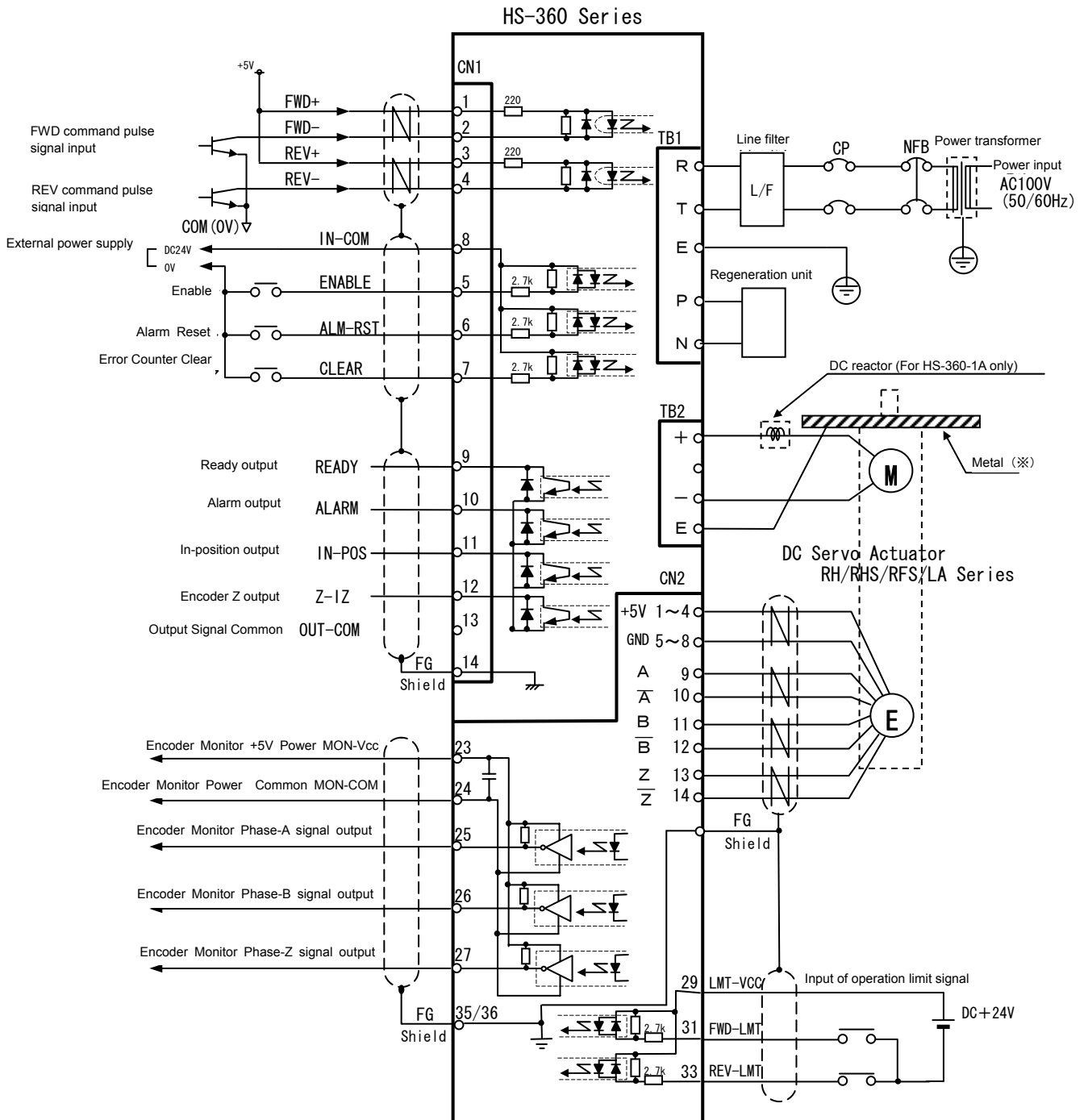

Note: The required voltage may be AC 100, depending on the combination with the actuator. Be sure to use the product with the predetermined.

※ : Be certain to connect the mounting part of the actuator and “E” of TB2 by wire. An encoder error (Alarm 02) may result if wire is not installed.

Chapter 4 Installing driver

4-1 Receiving Inspection

Check the followings when products are unpackaged.

● Inspection procedure

(1) Check the shipping item for any damage that may have been caused during transportation. If the item is damaged, immediately contact the dealer it was purchased from.

(2) On its side, the driver has the nameplate shown on the right.

The model of the driver is denoted in the "TYPE" field on the nameplate.

Check that the delivered model is exactly the product you ordered. Should it be a different model, immediately contact the dealer.

HARMONIC DRIVE SYSTEMS INC.	
TYPE	<input type="text"/>
INPUT VOL.	100VAC 50/60Hz
ADJ.	<input type="text"/>
SER. No.	<input type="text"/>
PT. No.	<input type="text"/>
 MADE IN JAPAN	

The model indication represents the following:

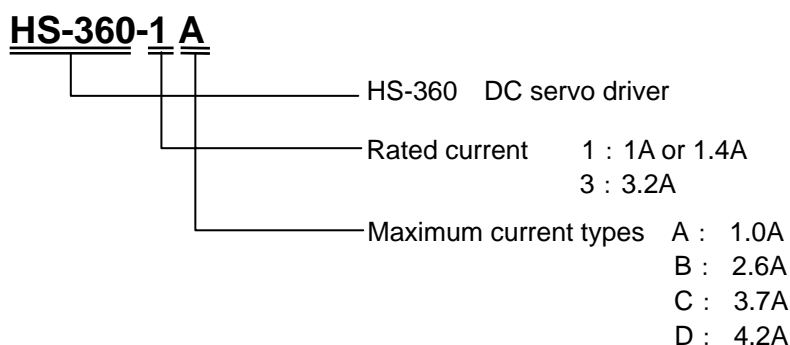

(3) The "ADJ." field on the nameplate shows the DC servo actuator model that must be used in combination with this HS-360 driver.



Warning

Do not combine the driver with any actuator that differs from the one shown on the nameplate.

The characteristics of the HS-360 driver have been factory-set according to the associated actuator. Combination with an incompatible actuator may cause it to burn because of insufficient torque or over current. If this happens, you may be injured, or fire may occur.

(4) Checking accessories

The following parts are attached as accessories. Check them.

- | | |
|------------------------------------|----------------------------------------------------------------|
| 1) CN1 External I/O Connector | Cover : 10314-52F0-008
Plug : 10114-3000VE (Manufacture:3M) |
| 2) CN2 Encoder Connector | Cover : 10336-52F0-008
Plug : 10136-3000VE (Manufacture:3M) |
| 3) TB1 Power supply terminal | Plug : 231-305/026-000 (Manufacture:WAGO) |
| 4) TB2 Actuator connector terminal | Plug : 231-304/026-000 (Manufacture:WAGO) |
| 5) TB1, TB2 | Operation lever: 231-131 |
| 6) DC Reactor (HS-360-1A Only) | : 15mH reactor |

(5) The driver input power supply voltage is shown in the "INPUT VOL." on the nameplate and at the top of the front panel of the driver. (Refer to Section 1-6, "Front panel".)



Warning

Do not connect the driver to any power supply the voltage of which differs from the value specified on the nameplate.

If the driver is connected to any power supply the voltage of which differs from the value specified on the nameplate, it may break, resulting in injury or fire.

100 : Single-phase, AC 100V

4-2 Notices on handling drivers

The drivers are electronic devices. Handle them with care and take the following precautions.



Warning

(1) Do not drop screws, solder balls, wire chips, or any other foreign objects through the ventilation gaps of the driver. Failure to observe this caution may result in electric shock or personal injury.

(2) Do not insert electric wire, steel wire, or a screwdriver through the ventilation gaps of the driver. Failure to observe this caution may result in electric shock or personal injury.



Caution

(1) Because the case is made of plastic, do not apply excess force or shock.

(2) The vibration resistance of the driver is 4.9m/s^2 (10 to 55Hz). Do not mount or transport the HS-360 driver in a manner where it would be subjected to high levels of vibration.

(3) Do not put the HS-360 driver on the place from where it can easily fall down.

(4) Do not put anything on the driver. The case of the driver may break.

(5) The allowable storage temperature is from -20°C to $+85^{\circ}\text{C}$. Do not expose it to sunlight for long periods of time, and do not store it in areas where temperatures are likely to fluctuate greatly.

(6) The allowable storage relative humidity is less than 90%. Do not store it in highly humid place or in areas where temperatures are likely to fluctuate greatly.

(7) Do not store the driver in areas where in corrosive gas or particles may be present

(8) When the driver is to be powered on again after the driver input power is turned off, do this after a lapse of 30s or more. It takes longer time to complete the startup due to the residual charge.

4-3 Location and installation

4-3-1 Environment of location

The environmental conditions of the location are as follows:

◆ **Service temperature:** 0°C to +50°C

Use the driver in a cabinet. The temperature in the cabinet can be higher than the atmosphere because of power loss of the housed devices and its size. Plan the cabinet size, ventilation system, and device locations so the ambient temperature of the driver, which is always less than 50°C.

◆ **Service humidity:** less than 90% relative humidity, without condensation

Make sure that water condensation does not occur due to fluctuating temperatures in the storage area or because of frequent heat-and-cool (run-and-stop) operations.

◆ **Vibration:** less than 4.9m/s² (0.5G) (10Hz to 55Hz)

When there is a great deal of vibration near the driver, attach a shock absorber under the base to dampen the vibration.

◆ **Impact:** less than 19.6m/s² (2G)

◆ **Make sure that dust, water condensation, metal powder, corrosive gas, water, water drops, or oil mist is not exposed to the HS-360 driver**

Do not install the driver in a corrosive gas environment, because the gas may cause damage to connecting parts (connectors, etc.).

◆ **Install the driver in a cabinet. Do not expose it to the sunlight.**

4-3-2 Notices on installation

Install the driver vertically and allow for wide spaces for air to flow sufficiently.

Leave 30mm or more from walls, 50mm or more from floor and 100mm from ceiling, and adjacent devices as shown the figure below.

When planning the ventilation system for the cabinet refer to the table below, which lists the power consumption of the driver.

Driver	HS-360-1 *	HS-360-3
Power consumption	20W	40W

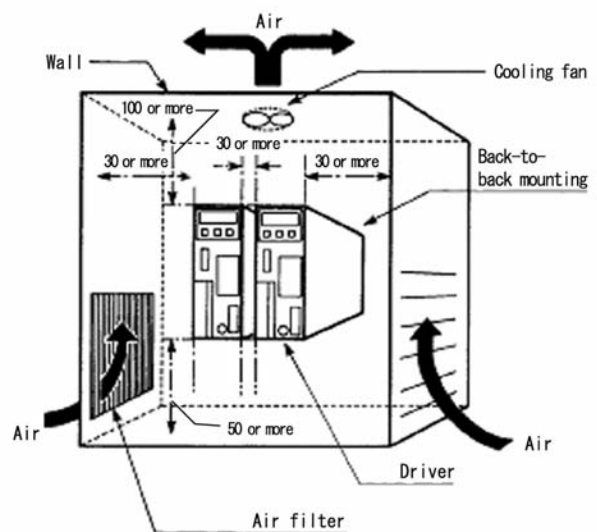

4-3-3 Installing

The HS-360 driver should be mounted on a wall as shown in the figure to the right.

Two mounting holes are provided on the back of the driver. The thickness of the wall should be more than 2mm.

● Procedure

- (1)Screw an M5 machine screw in the tapped hole on the wall.
- (2)Put the power mounting hole (cut hole) of the back of the driver on the M5 screw.
- (3)Screw tightly through the upper mounting hole with M5 screws.
- (4)Tighten the lower M5 screw.

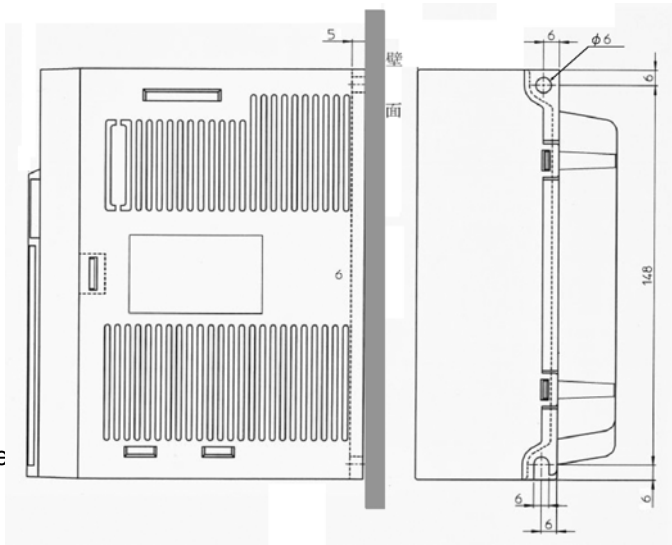

4-4 Suppressing noise

The HS-360 driver employs an IPM (power module) with a PWM control for main circuit. As the IPM generates switching noise by high-speed power switching, the noise may cause incorrect motion of other equipment or radio noise interference due to poor cabling or poor grounding.

In addition, it is necessary to provide proper cable management in order to suppress incorrect motion of the HS-360 driver by external noise from hosts, which contain electronic components, such as a CPU.

To prevent troubles by noise emissions always install cabling and grounding as follows:

4-4-1 Devices for grounding

Refer to the figure below when grounding all devices of the system.

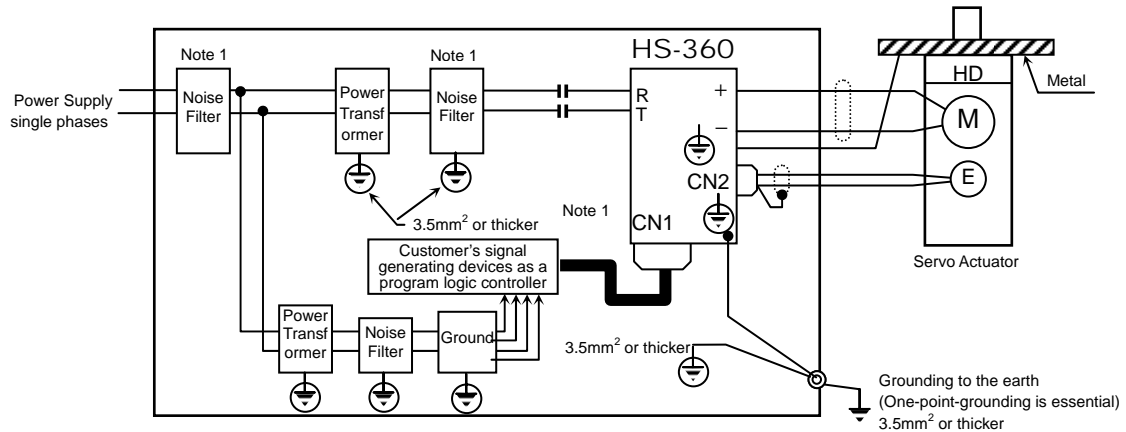

Note 1: For the grounding line filters refer to [4-4-2 installing noise filter].

● **Grounding motor frame**

When actuators are grounded at driven machine through the motor frame, current flows through floating capacity (Cf) of the motor from power amplifier of the driver. To avoid influence of the current, always connect the ground terminal (motor frame) of the motor to the ground terminal of the driver, and connect the ground terminal of the driver to the ground directly.

● **Grounding ducts**

When the motor cables are housed in a metal conduit or a metal box, ground their metal parts. The ground should be connected to earth at a single point.

4-4-2 Installing noise filters

Noise filters are recommended to guard against incorrect motion caused by impulse noise that may be emitted from power line and to suppress noise emissions to the line from inside of the driver simultaneously.

When plural drivers are used, ground noise filters for each driver.

Select bi-directional noise filters that can suppress external and internal noise.

Recommended noise filters are listed in the figure below:

Driver	Model	Ratings	Manufacturer
HS-360-1 *	SUP-P5H-EPR	250V,5A	Okaya Electric
HS-360-3	SUP-P10H-EPR	250V, 10A	

Install the noise filters and the HS-360 driver as near as possible with one another.

Install the noise filters to the lines of the electric devices other than the HS-360 driver in the same way. Especially, always install the noise filters to the source of high frequency noise, such as electric welders and electrical discharge machines.

Incorrect use of noise filters can seriously reduce its effectiveness. Inspect them with the following instructions:

◆ Separate the filtered side and the unfiltered side of the power supply cables from each other. Do not bundle both together. Do not encase them within the same duct.

◆ Do not bundle the grounding cable with the filtered side of power cables or signal wires. Do not encase them within the same duct.

◆ Avoid daisy-chain wiring of ground cables. Ground them to a frame box or ground plate at a single point.

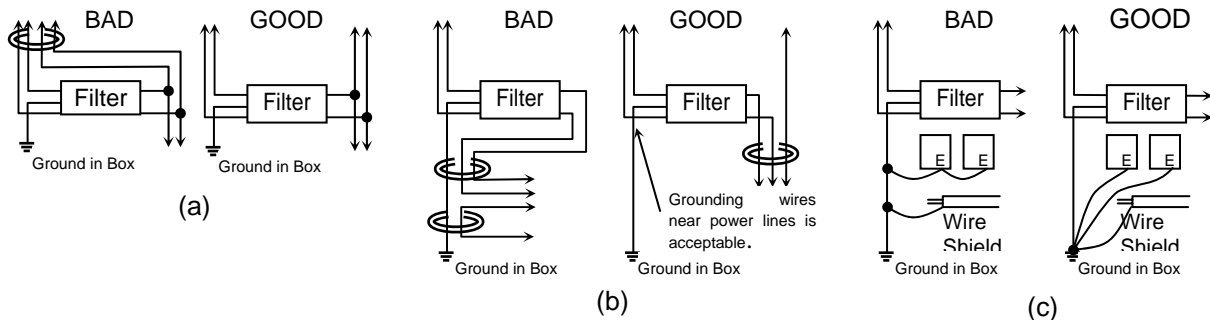

4-4-3 Instructions for cabling

In addition to the noise suppression mentioned previously, one must also follow these instructions:

- (1) Use shield cables for I/O signals. When a host controls several drivers, prepare I/O signal cables for each driver individually.
- (2) Use twisted pair cables for encoder signal cables.
- (3) Make the length of signal cables as short as possible.
 - (a) I/O signal cable: 3m or less
 - (b) Encoder signal cable (user's responsibility): 10m or less, providing that the condition of wire conductivity is less than 0.04 ohm/m.
- (4) Install surge protector devices to magnetic relays coils, magnetic switches, and solenoids.
- (5) Separate power cables (power source cables and motor cables) and I/O signal cables by more than 30cm. Do not encase both cables in one pipe or duct, and do not bundle them.
- (6) As the HS-360 driver is designed for industrial use, it provides no specific radio interference provisions. Accordingly, line filters should be inserted for the power supply cables in the event that the driver:
 - is used in the vicinity of private residences.
 - causes apparent radio interference.

4-5 Connecting power cables

4-5-1 Instructions for power supply



Warning

Before connecting the power cable to the HS-360 driver, turn-off the electricity to avoid electric shock. Failure to observe this caution may result in electric shock or personal injury.



Caution

- (1) Connect the power cable to the HS-360 driver only after installing the driver on a wall.
- (2) Ground the HS-360 driver, to avoid electric shock, malfunctions caused by external noise, and for the suppression of radio noise emissions.

4-5-2 Power cables and ground wires

The minimum allowable wire sizes of power cables, ground wires, and other cables are listed below. We recommend the thickest wires possible.

Terminal/connector	Symbol	Allowable Wire Sizes (mm ²)		
		HS-360-1A	HS-360-1B,1C,1D	HS-360-3
Power supply terminal	R,T	1.25		
Actuator connection terminal	+,-	0.3	0.5	0.75
Connection terminal	E	3.5		
Regeneration unit connection terminal	P,N	0.75		
External I/O connector	CN1	0.2mm ² shielded cable		
Encoder connector	CN2	0.3mm ² twist pair shielded cable		

Note 1. When bundling wires or encasing into conduits (plastic or metal pipes), use the wire of one upper size.

Note2. In hot environments, such as the temperature in a cabinet, use heat-resistant cable (IV or HIV).

4-5-3 Connecting power cables

The “terminal block for the power” is located on the front panel of the HS-360 driver. Use the operating lever annexed to the optional connector shown below.

Shown the figure to the right, strip the end of wires of the power supply cable and the motor cable, and connect wires to each terminal firmly.

Install “isolation transformer” and “noise filter” in the power lines to avoid electric shock and to guard against malfunctions caused by external noise.

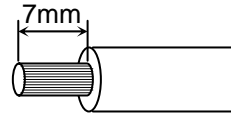

If the regeneration unit is required, connect this with "P, N" terminal.

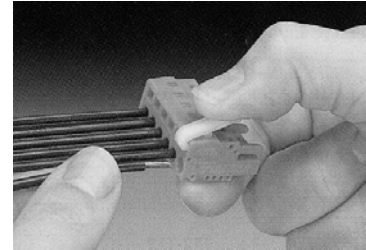
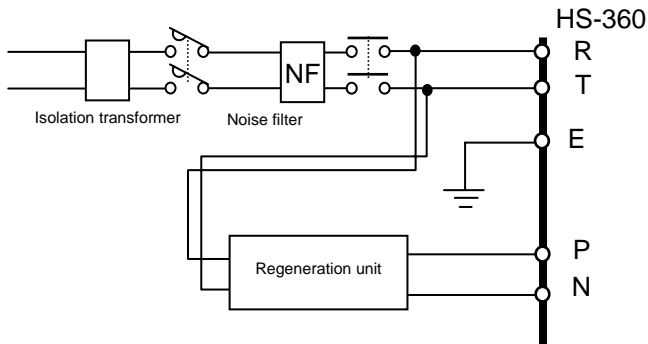

Plug: 231-305/026-000
(Manufacture: WAGO)

The driver contains a surge-current-suppress-circuit of capacitor type. Although the circuit reduces line voltage fluctuation, avoid daisy-chain wiring of the power lines, and connect units with a main switch.

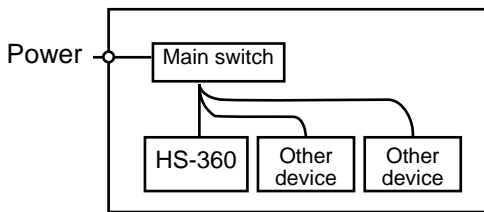

Good cable management

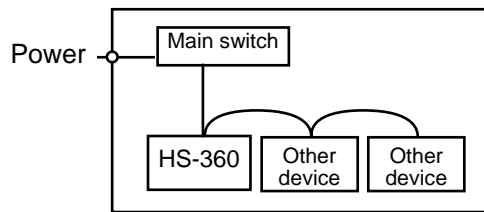

Bad cable management

4-5-4 Isolation transformer (sold optionally)

The use of an isolation transformer is recommended to prevent problems caused by improper grounding and external noises. Optional transformers for single-phase power supply are available as follows:

Isolation transformer	Driver
PT1-10002-100	HS-360-1A,1B,1C,1D
PT1-10004-100	HS-360-3

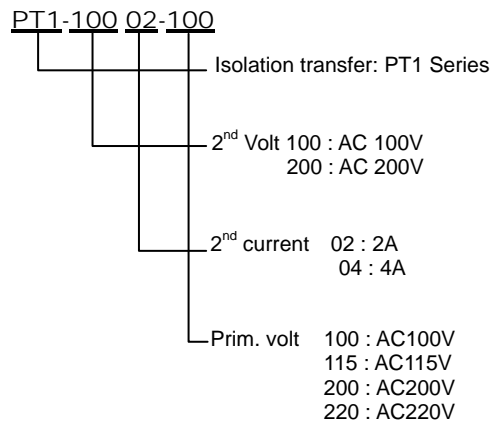

4-5-5 Protecting the power line

Be sure to use a circuit breaker (MCB) or circuit protector for the power line in order to protect it. Select the circuit breaker or protector based on the following table:

Combination of actuator and driver	HS-360-1A,1B,1C,1D	HS-360-3
Power interrupting capacity (A) of circuit protector Note 1	5	10
Required power capacity per driver (Kva) Note2	0.1	0.3
Power-on rush current (A) Note 3	8	15

Note 1: Use lag type for circuit protector and motor brake for brake
 Note 2: When the actuator allowable continuous output is in progress.
 Note 3: When the ambient temperature is 25°C.

4-6 Connecting the ground wire

Use an electric wire of the following size or more:

Terminal/connector	Symbol	Minimum allowable wire size (mm ²)
Grounding terminal (E)	Grounding mark	3.5

The HS-360 driver is provided with grounding terminal. Make connection between the ground with the cabinet and the grounding wire from the actuator.

The leakage current is generated at the maximum of 10mA.

Be sure to connect an electric wire with a cross section of 3.5mm² or more to the grounding terminal.

4-7 Connecting the actuator cable

Connect the actuator cable to the “+”, “-” and “E” terminals on the driver, as shown in the figure below. To do this, use the operating lever included with the product (refer to the figure below).

Before beginning, examine the phase sequence in an actuator technical material. Make connection between the terminals marked with the same symbol. For treatment of the cable end, refer to “Section 4-5-3, Connecting power cables”.

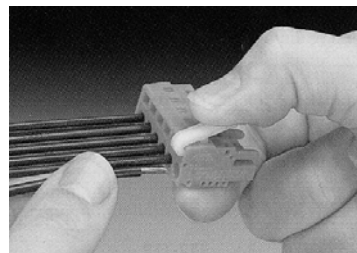

Plug : 231-304/026-000
 (Manufacturer WAGO)

4-8 Connecting cables for the encoder and the I/O

4-8-1 Preparing the encoder cable and the I/O cable

Follow these instructions for the preparation of the encoder cable and the I/O cable.

- (1) Use twisted pair cables for I/O signal cables and for encoder signal cables. When a host controls several drivers, install I/O signal cables for each driver individually.
- (2) Make the length of signal cables as short as possible.
 - ① I/O signal cable: 3m or less
 - ② Encoder cable (user's responsibility): 10m or less, providing that the condition of wire conductivity is less than 0.04 ohm/m
- (4) Separate power cables (power source cables and motor cables) and I/O signal cables more than 30cm. Do not encase both cables in one pipe or duct, nor bundle them.

Terminals/Connectors	Symbol	Allowable Wire Sizes (mm ²)
External I/O connector	CN1	0.2mm ² twist pair cable, or twist pair whole-shielded cable
Encoder connectors	CN2	0.3mm ² twist pair shielded cable

4-8-2 Pin layout of external I/O connector (CN1)

The models and the pin layout of the external I/O connectors are as follows:

Plug: Model 10114-3000VE
Cover: Model 10314-52F0-008

Manufacturer: 3M
Manufacturer: 3M

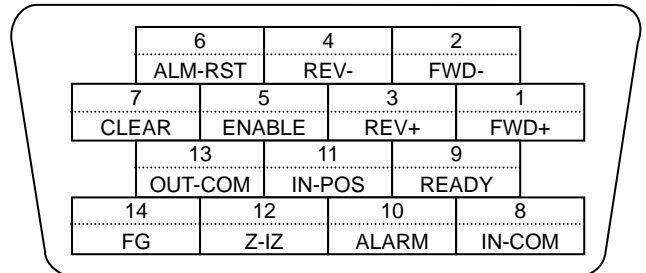
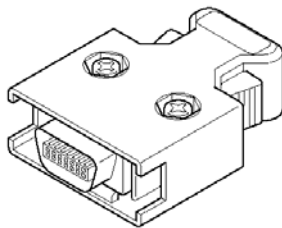

Viewed from soldering side

4-8-3 Pin layout of encoder connector (CN2)

The models and the pin layout of the encoder connectors are as follows:

Plug: Model 10136-3000VE
Cover: Model 10336-52F0-008

Manufacturer: 3M
Manufacturer: 3M

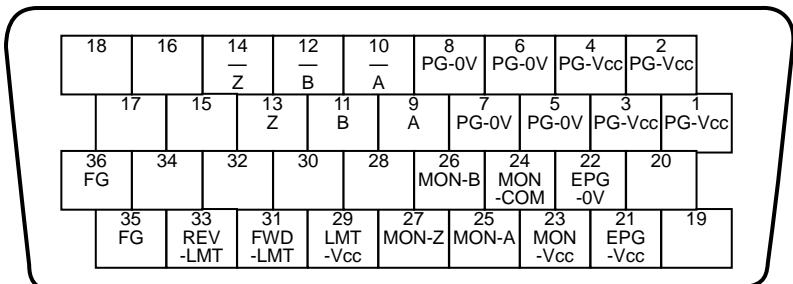
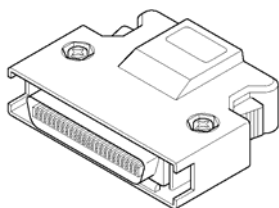

Viewed from soldering side

4-9 Power on and off sequences

Program the sequence on the high-level equipment to power on and off the HS-360 driver at the following timings:

● Power on/off sequences

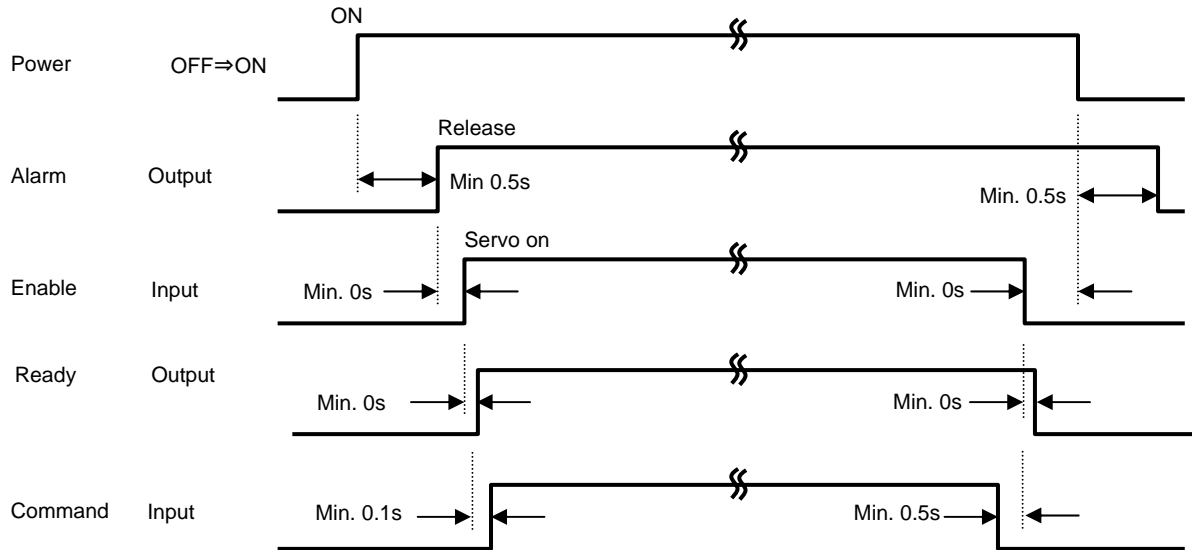

Chapter 5 Operations

Follow these instructions prior to operations.



Warning

1. **Inspect the cabling before turning the power ON and correct poor cabling if necessary.**
 - (1) Is the cabling correct?
 - (2) Is there any temporary cabling? Are all wires connected to the terminals?
 - (3) Are there any loose terminal connections?
 - (4) Are the wires grounded properly?
2. **Never wire the unit or make changes to the wiring while the power is ON. Turn the power OFF first.**
3. **Clean around the equipment. Make sure there are no wire chips or tools in the equipment.**

5-1 Trial run



Caution

1. **Complete the trial run before actual operation.**
2. **Drive the actuator only during the trial run; disconnect the actuator from the driven mechanism or load.**

Drive the actuator only without load during the trial run.

● Objectives for the trial run

- (1) Verifying the power cable wiring
- (2) Verifying the motor cable wiring (the servomotor cable and the encoder cable)

● Trial run procedure

◆ Powering on the driver and checking the power supply, motor, and encoder wiring

- (1) Power on the driver

- ☺ Check that no failure has occurred.
- ⇒ The state data mode display appears on the HS-360 driver.

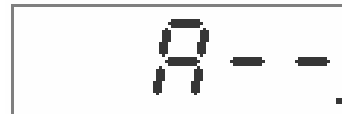

- (2) When a failure occurs, the alarm number blinks as shown in the figure below. This indicates that a failure was found regarding the power supply, motor, or encoder wiring. According to the instructions in Chapter 8, "Protective functions", power off the driver, and then check the wiring.

Example: When Alarm 02 [encoder failure] occurs, the alarm number blinks.

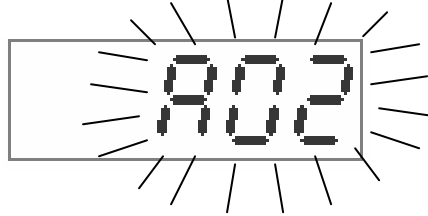

◆ **Operating the actuator by manual JOG**

By working with the built-in display panel, pulse command input can be checked, and the actuator rotation can be checked without connecting the input signal. Refer to "Chapter 6, Operating the display panel".

If the rotation does not take place normally, this indicates that a failure has occurred regarding the power, motor, or encoder wiring. In this case, power off the driver, and then check the wiring.

If normal operation is verified, terminate JOG. Move the mode to Monitor according to the instructions in Section 6-2, "Selecting a mode" in "Chapter 6, Operating the display panel".

This completes the entire trial run.

5-2 Usual operation

No particular operations are required because the HS-360 driver operates according to the commands from the higher-level system. When a failure occurs, the alarm number blinks as in the figure below. In this case, power off the driver and remove the alarm cause according to the instructions in “Chapter 8, Protective functions” and “Chapter 9, Troubleshooting”.

Example: When Alarm 02 [encoder failure] occurs, the alarm number blinks.

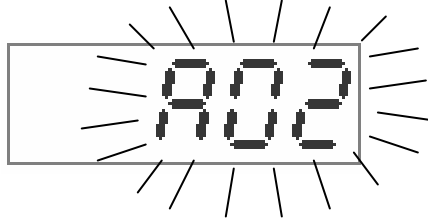

If the actuator does not rotate in response to pulse input while the normal state is on display, take action according to the instructions in a “Section 9-1, The actuator does not rotate” in “Chapter 9, Troubleshooting”.

This section describes notices on usual operations and daily maintenance.

5-2-1 Notices for daily operations



Warning

1. Do not make any wiring while power is active.

Disconnecting wires or connectors while power is active may cause electric shock or abnormal mechanical motion resulting in serious physical injury.

2. Immediately after the driver is powered off, do not touch any terminal.

The driver contains electricity inside also after being powered off. Do not touch any terminal until the charge voltage monitor LED goes out on the display panel.

3. Do not operate drivers with frequent ON/OFF operation.

Frequent power ON/OFF operation may cause deterioration of electronic elements. Start/stop operation should be performed with using input signals.

5-2-2 Daily maintenance

Since the HS-360 driver employs highly reliable parts, no special daily maintenance is required except the maintenance under user's rules for electronic equipment.



Warning

1. Shut down electric power before maintenance.

Maintenance while power is active may cause electric shock.

2. Immediately after the driver is powered off, do not touch any terminal.

The driver contains electricity inside also after being powered off.

To avoid electric shock, do not touch any terminal until the charge voltage monitor LED goes out on the display panel after being powered off.

3. Do not perform insulation resistance or high voltage breakdown tests.

The test causes damage to the HS-360 driver circuit that results in abnormal motion.

Check point	Interval	Inspection standard	Treatment
Terminal screws	Yearly	No loosen screws	Tightening screws
Exterior circuitry	Yearly	No dust or metal chips on the case	Cleaning
Interior circuitry	Yearly	No color change, no faults, no abnormalities	Consult with Harmonic drive systems

Chapter 6 Operating the display panel

The display panel of the driver is equipped with a five-digit LED display segment and four operation keys. This display segment can display all the information, and allows you to make all the adjustments, settings, and operations.

6-1 Outline of modes

The driver provides the following four modes:

● Monitor mode

While the driver is operating normally, its operating state is displayed with bits (refer to 6-3-1).

When an alarm occurs, the alarm number blinks (refer to 6-3-2). The view is forcibly changed to this display even when an alarm occurs when a non-monitor mode has been selected.

When the driver is powered on, the “monitor mode” page appears. After the driver is powered on, the mode can be changed from this page to another mode by operating a key as shown in the figure below.

● Parameter setup mode

This mode allows you to view or change servo parameters.

Parameters related to the basics of operation, including operation related to the higher-level system (e.g., loop gains, input signal configurations, electronic gear functions, speed/torque limits).

● Numeric monitor mode

This mode displays the alarm position, speed, torque data, and other information in real time. When the driver is operating normally, the servo operation state is displayed with bits.

● JOG operation mode

This mode allows JOG operation, and includes the functions required for testing in system construction.

6-2 Changing a mode

Immediately after being powered on, the driver automatically enters the “monitor mode”. The mode can be changed by using the “MODE” key on the front of the driver.

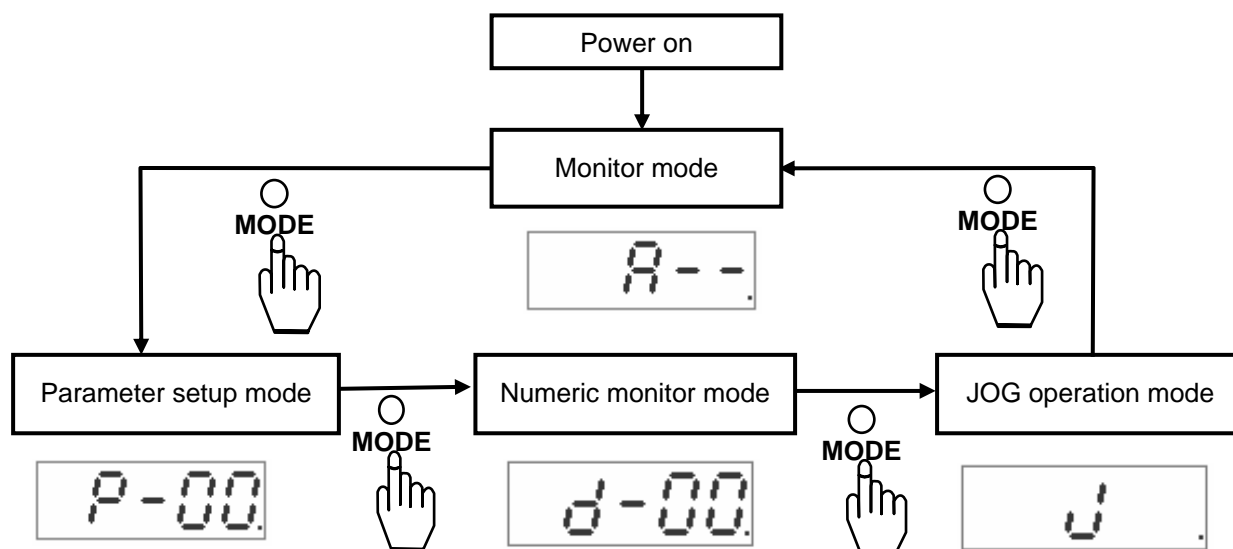

6-3 Monitor mode display details

6-3-1 Servo state display

When the middle character A remains displayed rather than blinking, this indicates that the driver is operating normally. The state is displayed on bit.

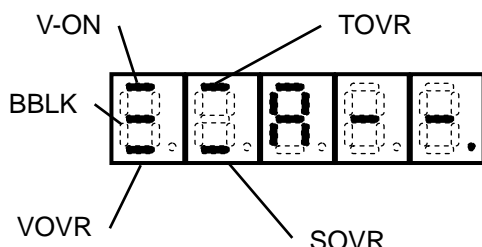

Bit	Description
V-ON	On while the AC 100 V supply voltage is being input.
BBLK	On while the servomotor is energized.
VOVr	On while the power supply voltage is being input with the servomotor energized.
TOVr	On while the torque is restricted.
SOVr	On while the speed is restricted.

6-3-2 Alarm state display

When an alarm occurs, the alarm number blinks as shown in the figure below. Even when an alarm occurs when a non-monitor mode has been selected, the view is forcibly changed to this display. In this case, pressing the MODE key changes the mode.

To take action against display of an alarm number, refer to "Chapter 8, Protective functions".

Example: When Alarm 02 [encoder failure] occurs, the alarm number blinks.

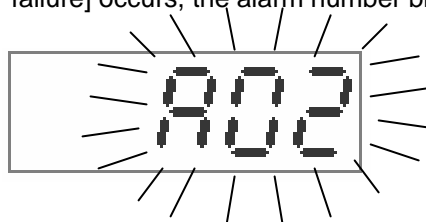

6-3-3 Resetting the alarm

Some alarms can be reset by pressing the UP and DOWN keys together in the monitor mode. If an alarm occurs that cannot be reset, power off the driver once. (For alarms that cannot be reset, refer to "Section 8-1, Protective functions".)

6-3-4 Displaying the alarm history

When the servo state is on display or alarm number is blinking, the alarm history is displayed pressing the DATA key. The alarm history code can be changed by pressing the UP or DOWN key at this time. The history contains up to eight alarm events.

Example: When Alarm 01 [overload failure] occurs as the sixth last alarm:



6-3-5 Clearing the alarm history

Alarm history information can be cleared by pressing the UP and DOWN keys together when an alarm is on display. The data disappears from the alarm number field at this time.



6-4 Outline of parameter setup mode

This mode allows you to view the servo or change parameters.

Parameters related to the basics of operation, including operation related to the higher-level system (e.g., loop gains, input signal configurations, electronic gear functions, speed/torque limits). The parameters are detailed in Chapter 7.

6-4-1 Operating parameter setup mode

Parameters can be viewed or changed using the procedure below.

Change to a parameter causes the data to be rewritten in EEPROM. (The changes to the data are also after the driver is powered off.)

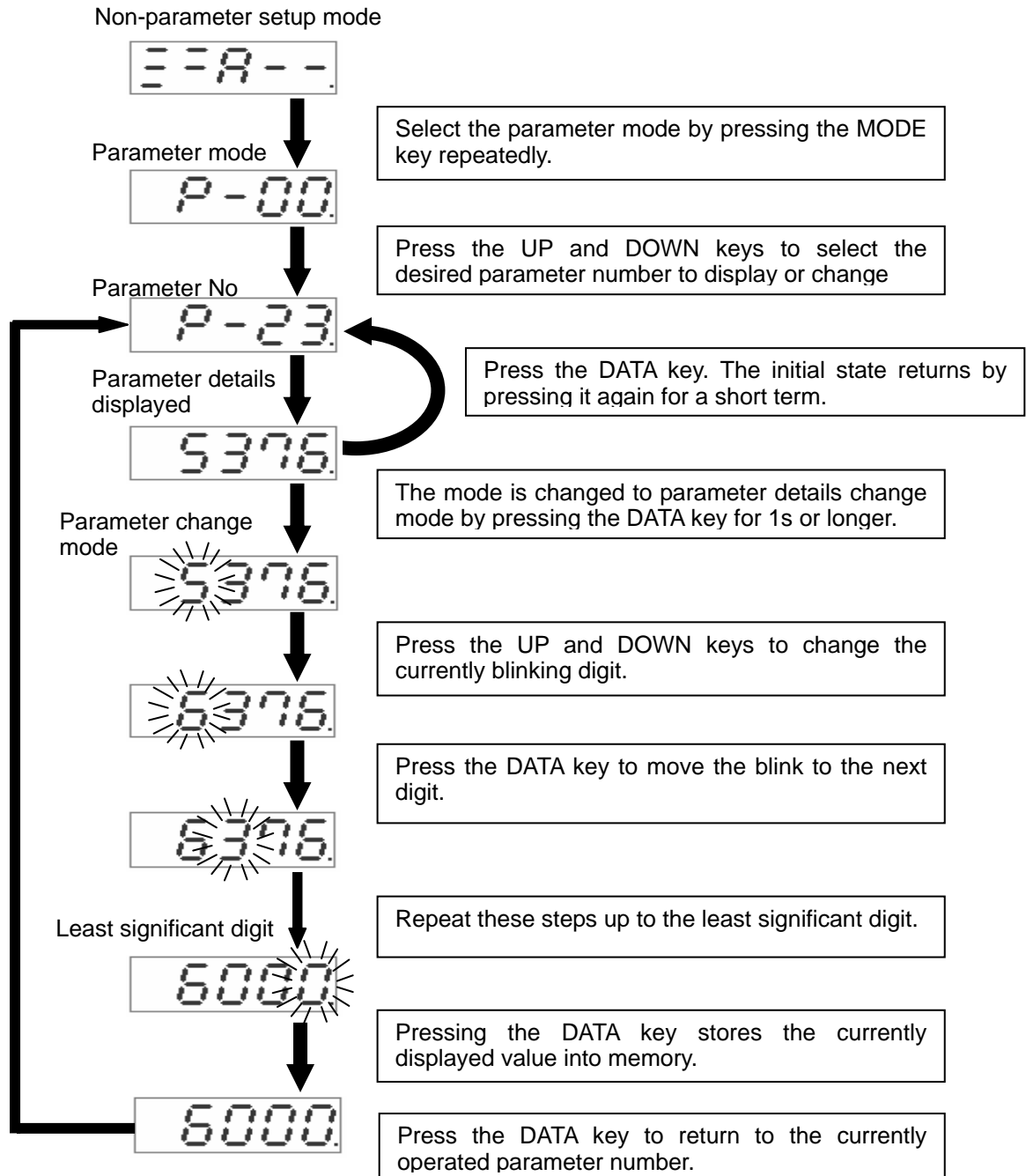

If the entered data exceeds the parameter setting range, or the MODE key is pressed during a change process, the pre-written, or initial, data is displayed with the data rewrite canceled. For performing operations for the parameter to display the higher or lower digit, refer to Section 6-7.

6-5 Outline of numeric monitor mode

The numeric monitor mode displays the position, speed, torque data, and other information about the actuator.

6-5-1 Numeric monitor list

Monitor No.	Contents	Unit	Digits displayed
00	Number of feedback pulses (encoder value multiplied by 4)	Pulses	High and low-order digits
01	Number of command pulses (encoder value multiplied by 4)	Pulses	High and low-order digits
02	Number of error pulses (encoder value multiplied by 4)	Pulses	High and low-order digits
04	Current speed (motor shaft) display	[r/min]	Low order digits only
05	Command speed (motor shaft) display	[r/min]	Low order digits only
06	Torque command	Rated torque (%)	Low order digits only
07	Effective duty ratio display	Rated torque (%)	Low order digits only
09	Torque peak display	Rated torque (%)	Low order digits only
14	Command pulse frequency display	Frequency (kHz)	Low order digits only
15	Stop cause display	—	Refer to Section 6-5-4.
16	Control state display	—	Refer to Section 6-5-5.
17	I/O state display	—	Refer to Section 6-5-6.

6-5-2 Displaying numeric monitor data

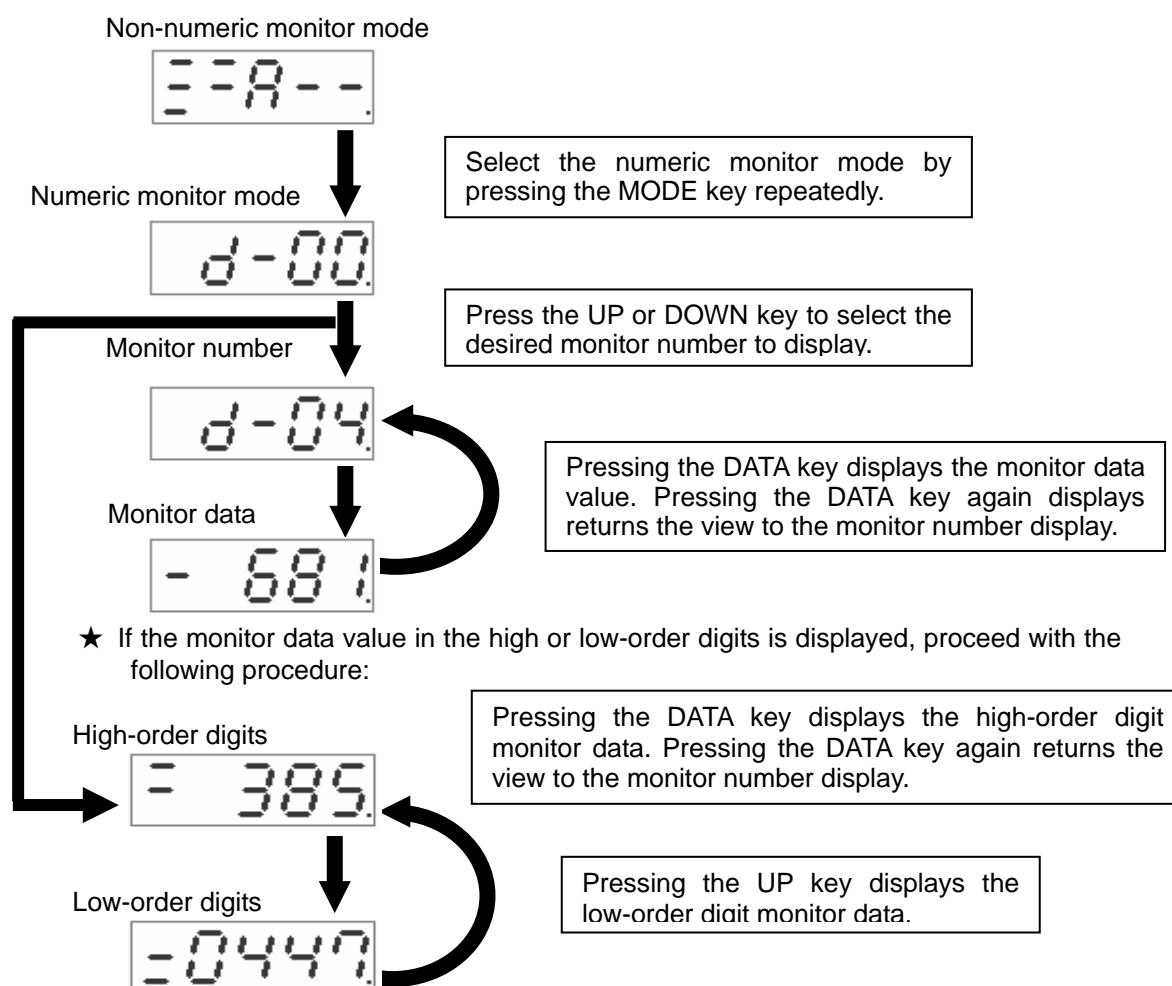

6-5-3 Clearing the torque peak

By pressing and holding down the UP and DOWN keys together while monitor number "9: Torque peak" is on display, the peak is updated with that of the torque values resulting while the keys are held down.

6-5-4 Displaying stop cause

Selecting Monitor No. 15 displays the stop cause.

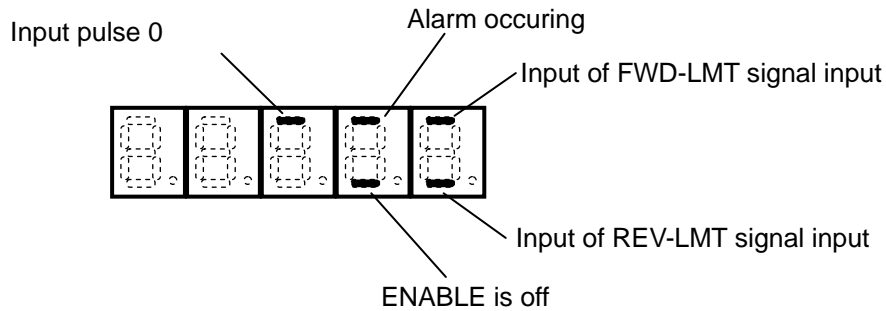

6-5-5 Displaying control state

Selecting Monitor No. 16 displays the servo state.

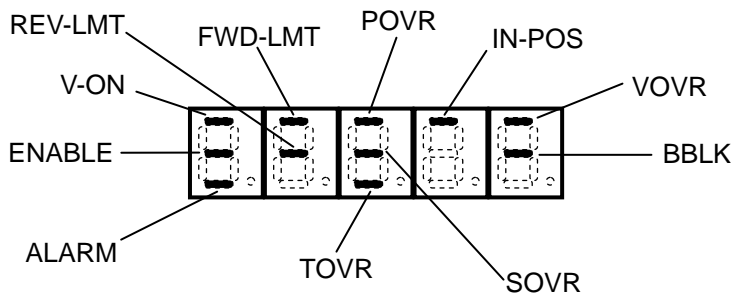

Control state display

Bit	Description
V-ON	On when the AC 100 V supply voltage is being input.
ALARM	On when an alarm has occurred.
ENABLE	On when the servo is on.
FWD-LMT	On when the FWD-LMT external input signal has been detected.
REV-LMT	On when the REV-LMT external input signal has been detected.
POVR	On when a position error allowance excessive alarm has occurred.
SOVR	On when the speed limit is working.
TOVR	On when the torque limit is working.
IN-POS	On when positioning is complete.
VOVR	On while over-voltage for power supply (DC 380V or more) is being applied with the servo on.
BBLK	On while the servomotor is energized.

6-5-6 Displaying I/O state

Selecting Monitor No. 17 displays the control I/O terminal state.

For both the input and output, the segments light up when the contact closes.

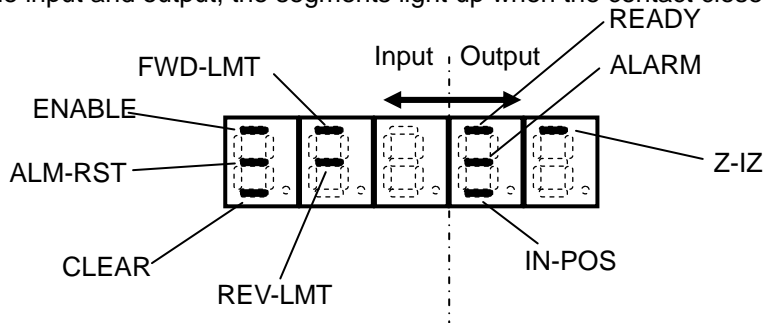

6-6 JOG operation mode

The JOG mode enables JOG operations.

6-6-1 JOG operations procedure

When JOG is off, the driver operates according to the pulse input commands. Even if the servo is on, the driver cannot be operated in JOG mode unless JOG is on.

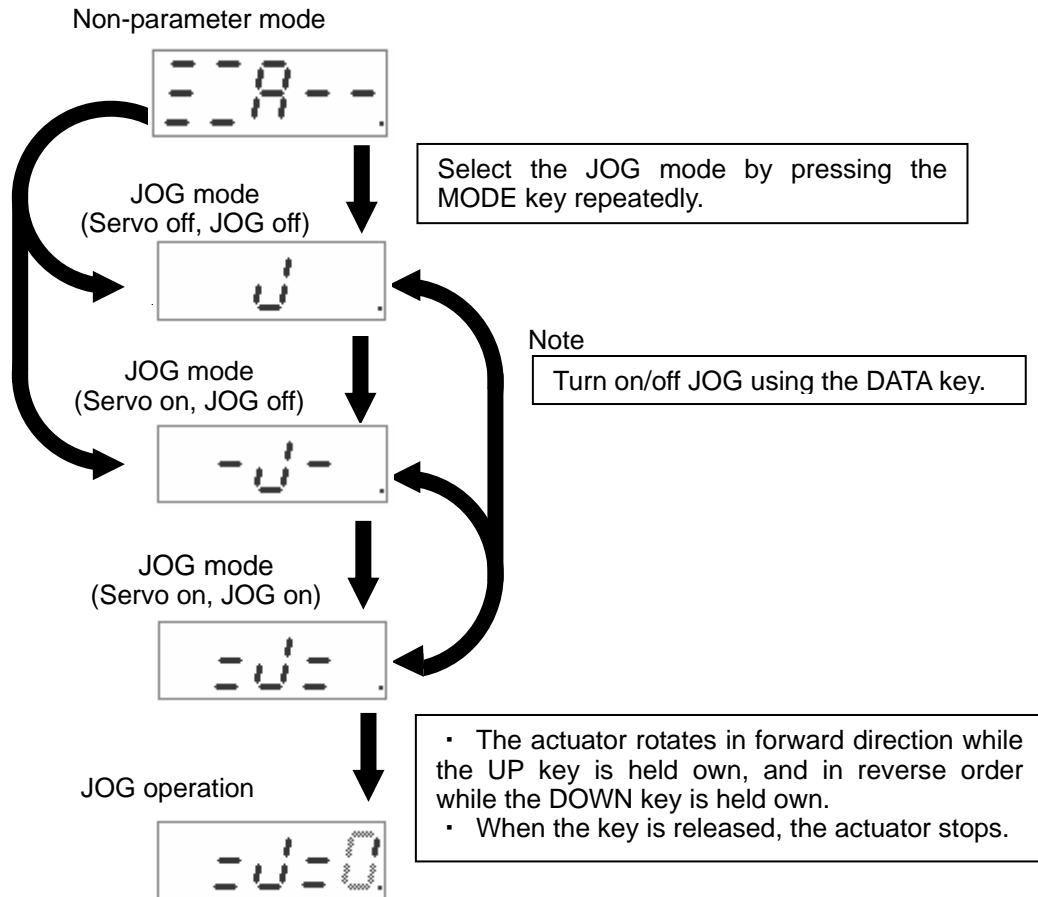

During JOG, the segments rotate in the rotary direction of the motor. However, if 1 has been set for [09: Rotary direction command] of [Parameter setup mode], the actuator will rotate in the reverse direction to the actuator rotation displayed with segments.

Note: When JOG is on, the mode cannot be changed even if the MODE key is pressed.

● JOG operation patterns

JOG operates in an environment that has been set up by the following parameters:

[19: JOG operation speed]

[20: JOG feed pulse count]

[40: JOG acceleration/deceleration time constant]

[43: JOG character-S selection]

For details, refer to “Chapter 7-2, Parameter details

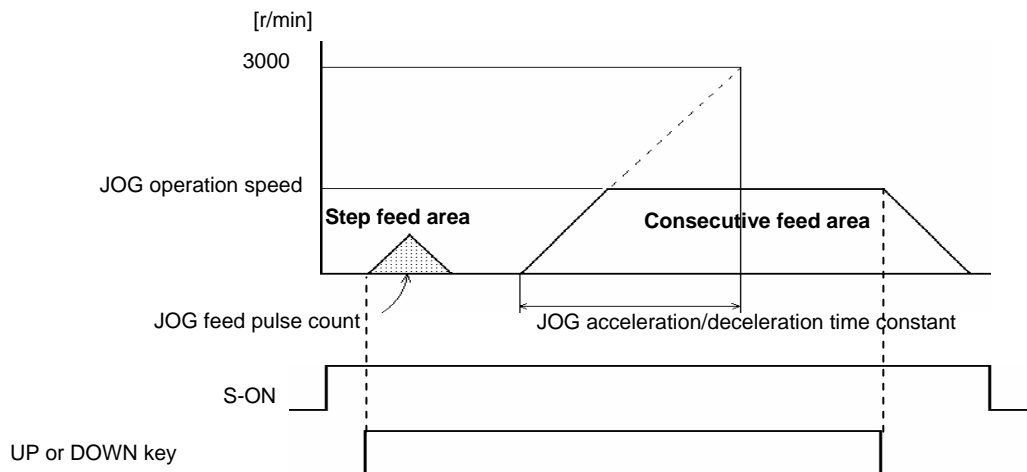

Step feed area: When the “UP” or “DOWN” key is pressed, the forward or reverse step takes place for the pulse count that has been set for [20: JOG feed pulse count] of [Parameter setup mode].

Consecutive feed actuator: When the “UP” or “DOWN” key is pressed and held down, the operation in the step feed takes place; the consecutive feed actuator is then entered, and the rotation continues at the speed that has been set for [19: JOG speed] of [Parameter setup mode]. Releasing the “UP” or “DOWN” key causes the actuator to decelerate and stop.

6-7 Displaying and setting data of high- and low-order digits

For numeric data of five or more digits, the high- and low-order digits are displayed separately.

	No.	Description	Lower limit	Upper limit
Parameter	P 0 0	Position error allowance	0	32767
Numeric monitor	d 0 0	Feedback pulse count (display of 4 times of encoder)	—	—
	d 0 1	Command pulse count (display of 4 times of encoder)	—	—
	d 0 2	Error pulse count (display of 4 times of encoder)	—	—

Example: Displaying/changing parameter No. 00 = 30000

Display of high-order digits

Display of low-order digits

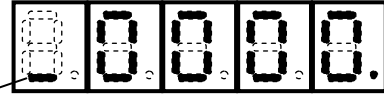
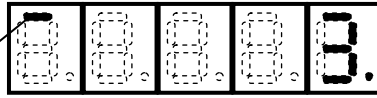

Lights up while the high-order digits are on display.

Lights up while the low-order digits are on display.

Parameter No.



High-order digits

Press the DATA key to display the high-order digits.



Low-order digits

Press the UP key to display the high-order digits. Press the DOWN key to display the low-order digits.



Note: The numeric monitor can only display a numeric value without permitting you to change it.

Changing the high-order digits

Press and hold down the DATA key for 1s or longer. The most significant digit blinks to indicate the change mode.



Each time the DATA key is pressed, the blink moves to the next lower digit.

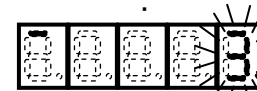

Press the DATA key at the right end to display the four lower digits.

Changing the low-order digits

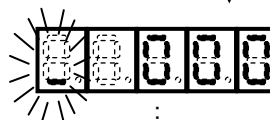

Press the DATA key at the least significant digit to complete the change.

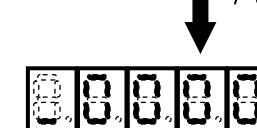
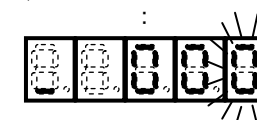

Chapter 7 Parameter details

7-1 Default setup parameters

The following table summarizes the default parameters:

Display	Parameter name	Unit	Lower limit	Upper limit	Default
00	Position error allowance	Pulse	0	32767	15000
01	In-position range	Pulse	0	9999	20
02	Position loop gain	S ⁻¹	10	9999	Note 1
03	Speed loop proportional gain	—	10	9999	Note 1
04	Speed loop integral gain	—	0	9999	Note 1
05	Speed loop action gain	—	0	9999	0
06	Speed feed forward factor	—	0	9999	0
07	Acceleration feed forward factor	—	0	9999	0
08	Torque command filter	—	0	9999	0
09	Rotational direction command	—	0	1	1
10	Electronic gear - numerator	—	1	999	1
11	Electronic gear - denominator	—	1	999	1
12	Speed step correction	—	0	9999	0
13	Torque step correction	—	0	9999	0
15	Forward torque limit	%	0	Note 2	Note 2
16	Reverse torque limit	%	0	Note 2	Note 2
19	JOG operation speed	r/min	0	Note 2	1000
20	JOG feed pulse count	Pulse	0	9999	100
21	2nd Position loop gain	S ⁻¹	10	9999	Note 4
22	2nd Speed loop proportional gain	—	10	9999	Note 4
23	2nd Speed loop integral gain	—	0	9999	Note 4
24	2nd control switching range	Pulse	0	9999	Note 4
28	Control input filter time constant	ms	0	99	0
29	— Note 3	—	0	0	0
31	Command pulse input configuration	—	0	2	2
33	Power supply voltage switch	—	0	1	0
38	Input pin logic setting(bit)	—	0(00h)	31(1Fh)	0
39	Output pin logic setting(bit)	—	0	7	0
40	JOG acceleration/deceleration	ms	1	9999	100
41	CLEAR signal function selection	—	0	1	1
42	Multiplication of 2-phase pulse	—	1	4	4
43	JOG character-S selection	—	0	1	0
44	Communication condition	—	0	23	12
45	Speed limit	r/min	0	Note 2	Note 2
46	Dynamic break on/off	—	0	2	1
47	Regeneration brake on/off	—	0	1	0

Note: For the procedure for changing a parameter setting, refer to "Chapter 6, Operating the display panel".

Note 1: The actual setting varies with the DC servo actuator model. When changing the setting, consider this default as the standard (guide setting).

Note 2: The maximum value that is determined, depending on the DC servo actuator model. No value above this can be set.

Note 3: Do not change the setting. If it is changed, the alarm will be unable to operate normally.

Note 4: A change is not necessary when operated under normal operating conditions. If controllability is not improved by "Parameter Mode No.: 02 to 05," controllability is sometimes enhanced by changing this parameter. Please consult Harmonic Drive Systems before making a change.

7-2 Parameter details

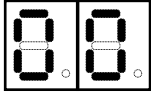

Position error allowance

● Function

This parameter specifies the allowable range of the difference (i.e., position error) between the command and feedback pulses in the control system.

If the position error exceeds this setting, [07: Excessive error alarm] is displayed. In this case, the servo shuts off, and the “ALARM” (CN1-10 pin) is output.

The relationship between the position error allowance, position loop gain, and electronic gear, and pulse command speed is determined by the following formula in the stationary state; a value matching the speed must be set for the maximum pulse command:

$$\text{Position error allowance} = \frac{\text{Pulse command speed (p/s)}}{\text{Position loop gain}} \times \frac{\text{Electronic gear - numerator}}{\text{Electronic gear - denominator}}$$

In addition, rotary operation is no longer enabled due to a mechanical failure against the actuator that attempts rotary operation by the command pulse input, and an alarm is output when the error pulse exceeds the allowance.

● Setting

Unit	Lower limit	Upper limit	Default
Pulses	0	32767	15000

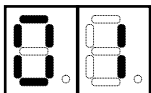

In-position range

● Function

When the difference (i.e., position error) between the command and feedback pulses decreases below this setting, the in-position signal “IN-POS” (CN1-11 pin) is output.

This value is only used to monitor the position error state.

It does not directly relate to rotational control of the DC servo actuator.

● Setting

Unit	Lower limit	Upper limit	Default
Pulses	0	9999	20

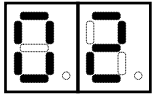

Position loop gain

● Function

This parameter specifies the gain of the position loop. And it determines the value based on the frictional torque and rigidity of the machine.

High setting \Rightarrow The position error is small, and high tracking performance to commands is obtained. If the setting is too high, the servo system will be unstable and hunting may easily occur; it should be decreased so that no hunting can occur.

Low setting \Rightarrow If the setting is too low, a problem may occur; for example, the tracking performance to commands may be poor, or position precision may not be obtained.

When no hunting occurs and neither overshoot nor undershoot occurs, set the maximum gain.

● Setting

Unit	Lower limit	Upper limit	Default
s^{-1}	10	9999	Note

Note: The actual setting varies with the DC servo actuator model. When changing the value, consider the defaults shown in Section 7-1, "Default parameters" as the standard (guide setting).

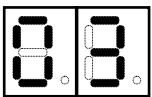

Speed loop proportional gain

● Function

This parameter specifies the proportional gain of the speed loop. Determine the value based on the moment of inertia, the frictional torque, and the rigidity of the machine.

High setting \Rightarrow If the setting is too high, the servo system will be unstable (hunting) and overshoot will easily occur.

Low setting \Rightarrow If the setting is too low, the responsiveness and tracking performance will be poor.

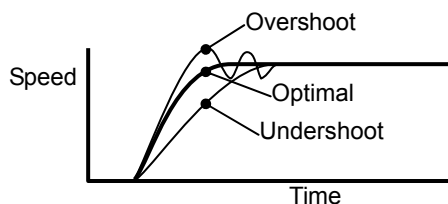

When no hunting occurs and neither overshoot nor undershoot occurs, set the maximum gain.

● Setting

Unit	Lower limit	Upper limit	Default
—	10	9999	Note

Note: The actual setting varies with the DC servo actuator model. When changing the value, consider the defaults shown in "Section 7-1, Default parameters" as the standard (guide setting).

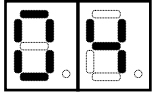

Speed loop integral gain

● Function

This parameter specifies the speed loop integral gain.

High setting ⇒ If the setting is too high, the servo system will be unstable (hunting) and overshoot will easily occur.

Low setting ⇒ If the setting is too low, the responsiveness and tracking performance will be poor.

● Setting

Unit	Lower limit	Upper limit	Default
—	0	9999	Note

Note: The actual setting varies with the DC servo actuator model. When changing the value, consider the defaults shown in "Section 7-1, Default parameters" as the standard (guide setting).

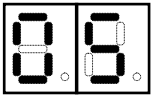

Speed loop action gain

● Function

This parameter specifies the speed loop action gain.
Generally, set this factor 0.

High setting ⇒ If the setting is too high, the servo system will be unstable (hunting) and overshoot will easily occur.

● Setting

Unit	Lower limit	Upper limit	Default
—	0	9999	0

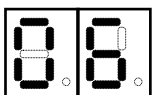

Speed feed forward factor

● Function

This parameter specifies the factor used to give the first-order derivative value to a speed command.
Usually set this factor to 0.

This setting is usually required to improve the speed.

● Setting

Unit	Lower limit	Upper limit	Default
—	0	9999	0

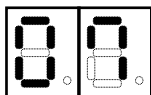

Acceleration feed forward factor

● Function

This parameter specifies the factor used to give the second-order derivative value to a torque command. Usually set this factor to 0.

This setting is usually required to improve the speed.

● Setting

Unit	Lower limit	Upper limit	Default
—	0	9999	0

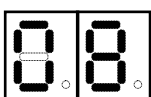

Torque command filter

● Function

For the purpose of suppressing the self-excited oscillation with the mechanical system, this parameter specifies the factor for the cutoff frequency of the low pass filter of a torque command. Usually set this factor to 0.

● Setting

Unit	Lower limit	Upper limit	Default
—	0	9999	0

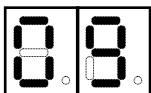

Rotary direction

(After the setting is changed, the driver must be powered on again.)

● Function

This parameter specifies the rotary direction of the actuator.

Note: For DC servo actuator, the rotary direction is reverse to the rotation that takes place when the monitor is used as a standalone machine. This is because the actuator is equipped with a harmonic drive decelerator.

0: When a forward command pulse is input, the actuator rotates in the counterclockwise direction relative to the actuator output shaft.

1: When a forward command pulse is input, the actuator rotates in the clockwise direction relative to the actuator output shaft.

* After the setting is changed, the power must be turned on again.

● Setting

Unit	Lower limit	Upper limit	Default
—	0	1	1

Note: The default is 1. When a forward command pulse signal is input, the actuator rotates clockwise relative to the actuator output shaft.

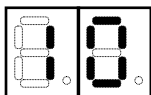

Electronic gear - numerator

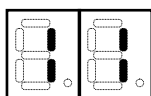

Electronic gear - denominator

(After the setting is changed, the power must be turned on again.)

● Function

This parameter provides consistency between the amount of movement specified with a command and the actual amount of movement of the machine. This is achieved by multiplying the position command value by a factor.

This parameter is useful to associate the control unit with the angular unit during rotation. For a direct action system, it is also useful to provide association with the feed relative to the ball screw pitch.

◆ For rotary operation:

$$\text{Angle of movement per input pulse} = \frac{\text{Command pulse input factor - numerator}}{\text{Command pulse input factor - denominator}} \times \frac{360}{\text{*Actuator resolution}} \times \frac{1}{\text{Reduction ratio of load mechanism}}$$

◆ For linear operation:

$$\text{Angle of movement per input pulse} = \frac{\text{Command pulse input factor - numerator}}{\text{Command pulse input factor - denominator}} \times \frac{\text{Load mechanism feed pitch}}{\text{*Actuator resolution}}$$

* Actuator resolution = Encoder resolution (4 times) x Actuator duty

On the basis of this formula, set the parameter value so that both the numerator and denominator will be integers.

* After the setting is changed, the power must be turned on again.

● Setting

	Unit	Lower limit	Upper limit	Default
Numerator	—	1	999	1
Denominator	—	1	999	1

Note: By default, the internal pulse is performed with the encoder resolution (4 times). The amount of movement of the actuator will thus be the one corresponding to the encoder resolution (4 times).

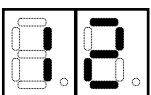

Speed step correction

● Function

This parameter specifies the speed command correction amount that is to be added to the speed command, depending on the positive or negative amount in the command.

Usually set this parameter to 0, but it should be set when the speed is to be improved.

High setting ⇒ If the setting is too high, the servo system will be unstable (hunting) and overshoot will easily occur.

● Setting

Unit	Lower limit	Upper limit	Default
—	0	9999	0

The setting relates to the one in [24: Step correction switching range] of [Parameter setup mode].

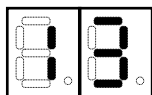

Torque step correction

● Function

This parameter specifies the torque command correction amount that is to be added to the torque command, depending on the positive or negative amount in the command. Usually set this parameter to 0, but it should be set when the speed is to be improved.

High setting ⇒ If the setting is too high, the servo system will be unstable (hunting) and overshoot will easily occur.

● Setting

Unit	Lower limit	Upper limit	Default
—	0	9999	0

The setting relates to the one in [24: Step correction switching range] of [Parameter setup mode].

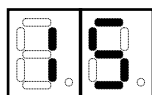

Forward torque limit

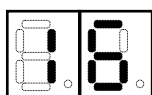

Reverse torque limit

● Function

This parameter specifies the maximum value of the forward or reverse torque with the percentage relative to the rated torque.

● Setting

Unit	Lower limit	Upper limit	Default
%	0	Note	Note

Note: The actual setting varies with the AC servo actuator model. The upper limit is calculated by assigning to the following formula the values listed in the brochure or technical material. The rated torque is defined as 100%.

Maximum momentary torque ÷ Rated torque x 100 (%) = Lower limit (default, %)

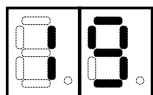

JOG operation speed

● Function

This parameter specifies the maximum revolution speed of the motor that operates according to JOG commands.

● Setting

Unit	Lower limit	Upper limit	Default
r/min	0	Note	500

Note: The upper limit is restricted, depending on the DC servo actuator model.
The upper limit is determined by the following formula:

Upper limit of JOG speed = Maximum revolution speed of actuator x Reduction ratio

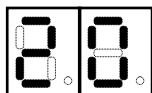

JOG feed pulse count

● Function

When the "UP" or "DOWN" key is pressed in JOG mode during JOG operation, forward or reverse rotation takes place until the pulse count set for this parameter is reached.

This parameter corresponds to the step feed actuator that is shown in the figure in "Section 6-6-1, JOG operations procedure".

If a large pulse count is set, the maximum revolution speed will equal the value in [19: JOG speed] of [Parameter setup mode].

● Setting

Unit	Lower limit	Upper limit	Default
Pulse	0	9999	100

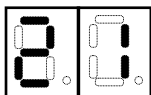

2nd position loop gain

● Function

A position loop gain that functions when the cumulative number of pulses in the deviation counter falls below the pulse number set by "Parameter setting mode" → "24: "2nd control switching range."

● Setting

Unit	Lower limit	Upper limit	Default
S ⁻¹	10	9999	Note

Note: Setting of this parameter is not required for servo operations under normal operating conditions. Setting is sometimes effective for applications that require enhanced controllability. This function does not operate if the value in "Parameter" → "24: "2nd control switching range" is "0."

Be certain to consult the HarmonicDrive System sales office about a set value when a value other than "0" is set to enable this function.

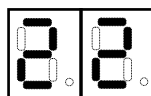

2nd Speed loop proportional gain

● Function

A speed loop proportional gain that functions when the cumulative number of pulses in the deviation counter falls below the pulse number set by "Parameter setting mode" → "24: "2nd control switching range."

● Setting

Unit	Lower limit	Upper limit	Default
—	10	9999	Note

Note: Setting of this parameter is not required for servo operations under normal operating conditions. Setting is sometimes effective for applications that require enhanced controllability. This function does not operate if the value in "Parameter" → "24: "2nd control switching range" is "0."

Be certain to consult the Harmonic Drive System sales office about a set value when a value other than "0" is set to enable this function.

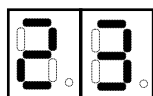

2nd Speed loop integral gain

● Function

A speed loop integral gain that functions when the cumulative number of pulses in the deviation counter falls below the pulse number set by "Parameter setting mode" → "24: "2nd control switching range."

● Setting

Unit	Lower limit	Upper limit	Default
—	0	9999	Note

Note: Setting of this parameter is not required for servo operations under normal operating conditions. Setting is sometimes effective for applications that require enhanced controllability. This function does not operate if the value in "Parameter" → "24: "2nd control switching range" is "0."

Be certain to consult the HarmonicDrive System sales office about a set value when a value other than "0" is set to enable this function.

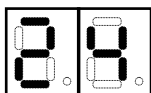

2nd control switching range

● Function

This parameter is controlled by a gain set by “Parameter setting mode” → 21: “2nd position loop gain,” 22: “2nd speed loop proportional gain” and 23 “2nd speed loop integral gain” when the cumulative number of pulses in the deviation counter falls below the pulse number set here.

● Setting

Unit	Lower limit	Upper limit	Default
Pulse	0	9999	0

Note: Use this parameter as it is set to “0” for operations under normal operating conditions. Be certain to consult the HarmonicDrive System sales office before changing this parameter when a change seems necessary.

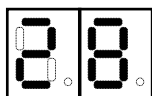

Control input filter time constant

● Function

This parameter specifies the time constant of the soft low pass filter to be applied to control input terminal signals other than forward and reverse command pulses.

If the driver is used in an environment where external high-frequency noise is generated, the control input signals may experience interference.

● Setting

Unit	Lower limit	Upper limit	Default
ms	0	99	0

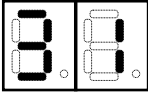

Command pulse input configuration

(After the setting is changed, the power must be turned on again.)

● Function

This parameter specifies the pulse input configuration.

0: 2-phase pulse (90-degree phase difference)

1: 1-pulse

A pulse is input for Phase-A input, and a code for Phase-B input.

2: 2-pulse

A pulse is input for FWD or REV.

The rotary direction indicates operation of the standalone motor. For DC servo actuator RH Series, the rotary direction will be reverse because it is equipped with a harmonic drive reduction gear.

For details, refer to “Section 3-2, Selecting the command pulse input configuration”.

Setting	FWD Command	REV Command
0		
1		
2		

● Setting

Unit	Lower limit	Upper limit	Default
—	0	2	2

* After the setting is changed, the power must be turned on again.

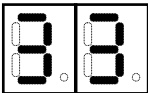

Power supply voltage switch

(After the setting is changed, the power must be turned on again.)

● Function

This parameter switches the power supply voltage.

0: 100V Always set to “0” and do not change.

● Setting

Unit	Lower limit	Upper limit	Default
—	0	1	0

The setting can be changed. However, the actuators manufactured by HarmonicDrive System are based on 100V specification. Do not change to a value other than “0.”

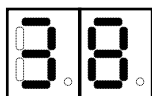

Input pin logic setting(bit)

(After the setting is changed, the power must be turned on again.)

● Function

This parameter specifies the logic that enables the functionality of external input signals.

Setting procedure:

Using the table below (in decimal notation), sum up the desired values of the logics to be set. Then, convert the sum into a hexadecimal number (h).

Example:

To set the error counter clear and forward/reverse inhibit input command to Open and the other to Close, convert the following into a hexadecimal number (h): $0 + 0 + 4 + 8 + 16 = 28$ (dec.). The resulting value is 1Ch. Set 1C for the parameter.

Signal	Circuit state where the input signal has the meaning	
	Close	Open
CN1-5 Enable :ENABLE	0	1
CN1-6 Alarm reset :ALM-RST	0	2
CN1-7 Error counter clear :CLEAR	0	4
CN2-31 Forward inhibit :FWD-LMT	0	8
CN2-33 Reverse inhibit :REV-LMT	0	16

● Setting

Unit	Lower limit	Upper limit	Default
—	0h(0)	1Fh(31)	0h

* After the setting is changed, the power must be turned on again.

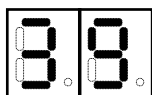

Output pin logic setting(bit)

(After the setting is changed, the power must be turned on again.)

● Function

This parameter specifies the logic used to determine the functional operation state of external output signals. Using the table below, sum up the desired values of the logic to be set, and set the sum for the parameter.

Example:

To set the ready, in-position, and alarm output off command, set 7 for the parameter rather than $1 + 2 + 4 = 7$.

Signal	Circuit state where the input signal has the meaning	
	ON	OFF
CN1-9 Ready :READY	0	1
CN1-11 In-position :IN-POS	0	2
CN1-10 Alarm :ALARM	0	4

● Setting

Unit	Lower limit	Upper limit	Default
—	0	7	0

* After the setting is changed, the power must be turned on again

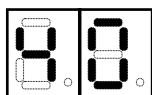

JOG acceleration/deceleration time constant

● Function

This parameter specifies the acceleration/deceleration time that is needed to reach 3,000r/min with the JOG motor shaft.

● Setting

Unit	Lower limit	Upper limit	Default
ms	1	9999	100

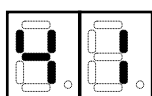

CLEAR signal function selection

● Function

This parameter specifies the input signal with which one, to clear the error counter.

0: Clears the error counter when the CLEAR signal is input.

1: Clears the error counter when the ALM-RST or ENABLE signal is input.

● Setting

Unit	Lower limit	Upper limit	Default
—	0	1	1

Note: Setting this parameter to 1 disables the function of the error counter input signal [CN1-7: CLEAR].

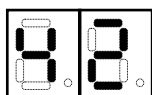

Multiplication of 2-phase pulse

(After the setting is changed, the power must be turned on again.)

● Function

This parameter is available also when 0 is set for [31: Command configuration] of [Parameter setup mode] (selecting of 2-phase pulse train).

1: 1 time

2: 2 times

4: 4 times

● Setting

Unit	Lower limit	Upper limit	Default
—	1	4	4

* After the setting is changed, the power must be turned on again

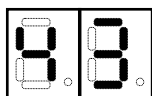

JOG operation character-S selection

● Function

This parameter specifies that character S can be selected during JOG operation.

0: Character S off (linear acceleration/deceleration)

1: Character S on (character S acceleration/deceleration)

● Setting

Unit	Lower limit	Upper limit	Default
—	0	1	0

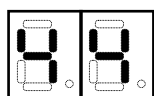

Communication condition

(After the setting is changed, the power must be turned on again.)

● Function

This parameter specifies the EIA232C (RS-232C) communication baud rate and parity bit.

Set the baud and parity bit values based on the following table:

Baud rate (bps) \ Parity bit	Baud rate (bps)							
	38400	28800	19200	14400	9600	4800	2400	1200
EVEN	0	3	6	9	12	15	18	21
ODD	1	4	7	10	13	16	19	22
NONE	2	5	8	11	14	17	20	23

● Setting

Unit	Lower limit	Upper limit	Default
—	0	23	12

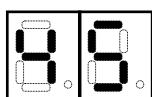

Speed limit

● Function

This parameter limits the revolution speed of the motor shaft.

When this value (+10r/min) is exceeded by 0.5s or more, an over-speed alarm occurs.

● Setting

Unit	Lower limit	Upper limit	Default
r /min	0	Note	Note

The revolution speed of the actuator is as shown in the following formula:

Speed limit = Maximum revolution speed of actuator x Reduction ratio

Note: This parameter specifies the upper limit that was determined by the actuator motor or reduction gear.

This parameter cannot be set to any value beyond the default.

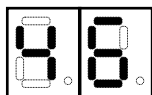

Dynamic brake on/off

● Function

This parameter specifies whether or not the dynamic brake should be when an alarm occurs, operated with the servo-off.

0: If the servo is turned on once in the on state, when the driver is powered on. After this, the brake does not operate.

1: The brake operates when either the driver is powered on or an alarm occurs.

2: The brake operates when either the driver is powered on or the servo is turned off.

* When the driver is powered off, the dynamic brake is always in operation.

● Setting

Unit	Lower limit	Upper limit	Default
—	0	2	1

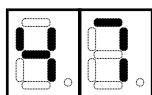

Regeneration brake on/off

● Function

If this parameter is set on, input of a servo-on signal causes an emergency stop according to the driver control (regeneration brake), and the servo is turned off after it stops.

If this parameter is set off, input of a servo-on signal causes an immediate servo-off according to the driver control, and the motor is left free.

0: Does not operate the regeneration brake.

1: Operates the regeneration brake.

● Setting

Unit	Lower limit	Upper limit	Default
—	0	1	0

Chapter 8 Protective functions

8-1 Outline of protective functions

The HS-360 driver contains various functions that protect the alarm and driver from abnormal circumstances. When one of them operates, the actuator driving stops and a two-digit alarm code is displayed in the display panel segment.

When an alarm occurs, an external output [ALARM] signal is output with the motor placed in the servo-off state. An emergency stop may occur, or the servo-free mode may be entered, depending on the setting of parameter No. 46 [Dynamic brake on/off].

Alarm code	Alarm name	Description of detection	Alarm clear
00	Memory failure	Indicates that an attempt to read or write data for EEPROM resulted in failure.	Impossible
01	Overload	Indicates that the motor remains overloaded with its electronic thermal detector.	Possible
02	Encoder failure	Indicates that cable disconnection of the motor encoder was detected.	Impossible
03	Regeneration failure	Indicates that over supply voltage was detected.	Impossible
04	Overheat	Indicates that the temperature of the driver's radiator plate exceeded the allowable temperature (75°C).	Possible
05	CPU failure	Indicates that the system has operated abnormally due to an unknown cause.	Impossible
06	Over-current	Indicates that motor current exceeding the predetermined level flowed for 1ms or longer.	Impossible
07	Excessive error	Indicates that the amount of accumulated pulses for command pulses exceeded the parameter error limit.	Possible
09	IPM failure	Indicates that the IPM does not operate normally.	Impossible
12	Over-speed	Indicates that the revolution speed of the motor exceeded the speed limit plus 10rpm for 0.5s or longer.	Possible

Below are details of the causes of alarms and actions against them.

Note: If any alarm is indicated as "Alarm clear: Impossible", turn off the power first of all before taking action against the alarm. After the cause of the alarm has been resolved, turn on the power again.

In addition, if the driver system can no longer continue control due to noise or another cause, the display blinks, as follows, in the LED display segment on the front of the body:

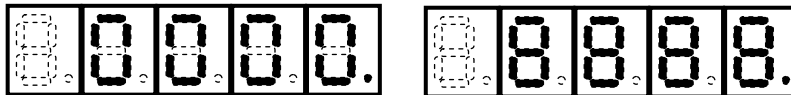

All operations are disabled, and alarm signal output does not take place at this time. Remove the cause of the alarm, and then power on the driver. If the alarm is not yet reset, contact a business office of Harmonic Drive Systems.



Warning

1. During troubleshooting, do not perform wiring with power on. Before beginning wiring, be sure to power off the driver.
2. Clear up objects around the equipment. In particular, make a careful inspection to ensure that no extra objects (e.g., chips of wires, tools) remain in the equipment.
3. If two or more persons are working with the equipment, before powering it on make arrangements to bear mutual safety in mind.

8-2 Details of protective functions

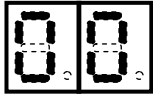

Memory failure (Alarm clear: Impossible)

● Description

This function indicates that an alarm has occurred due to driver EEPROM memory failure. This alarm cannot be reset.

● Possible causes

(1) If the alarm occurs when the power is turned on:

- ◆ Cause 1: Failure in HS-360 driver control circuit
⇒ Action: Contact a business office of Harmonic Drive Systems.
(Replacing the HS-360 driver)

(2) If the alarm occurs during operation:

- ◆ Cause 1: A device of the HS-360 driver control circuit malfunctioned.
⇒ Action: Contact a service department or a business office of Harmonic Drive Systems.
(Replacing the HS-360 driver)

In addition, check whether there is any improper point regarding the ambient conditions for the location of instruction. Do this according to the instructions in “Section 4-3, Location and installing”.

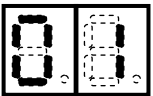

Overload (Alarm clear: Possible)

● Description

This function continuously monitors the motor current. When both the current and the time applied exceed the curve shown in the figure, this function causes an overload alarm to occur.

For example,

(1) When a current of approximately 1.2-times the actuator rated current is generated for a long time, the alarm occurs.

(2) When a current of approximately 3-times the actuator rated current is generated for approximately 20s, the alarm occurs.

● Possible causes

(1) If alarm occurs when the power is turned on:

- ◆ Cause 1: A device of the HS-360 driver control circuit malfunctioned.
⇒ Action: Contact a service department or a business office of Harmonic Drive Systems.
(Replacing the HS-360 driver)

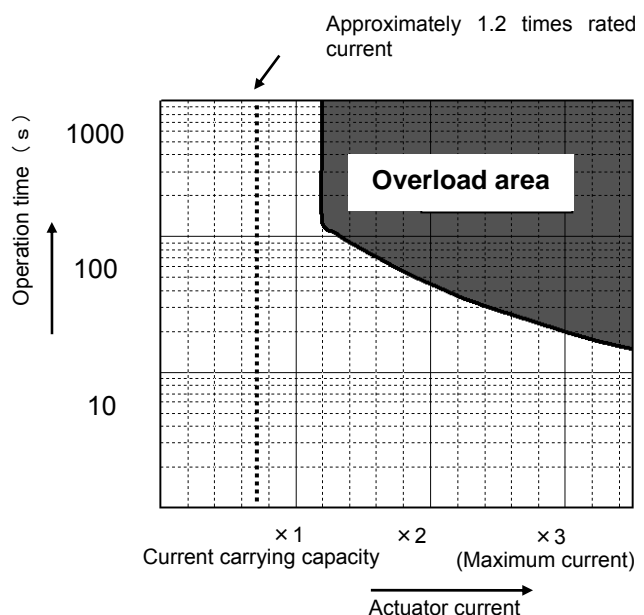

(2) If the alarm occurs when the servo is powered on:

- ◆ Cause 1: The encoder connector (CN2) is not connected.
⇒ Action: Check whether the encoder connector (CN2) is connected properly.

(3) If the alarm occurs during operation of overload with the actuator:

- ◆ Cause 1: Overloaded operation
⇒ Action: Reconsider the effective duty ratio of the actuator to decrease it.

(4) If the alarm occurs after the actuator continues hunting:

- ◆ Cause 1: Hunting phenomenon occurs due to defect of gain adjustment
⇒ Action: Make the following adjustments so that the actuator matches the load:
[Parameter setup mode] → [02: Position loop gain], [03: Speed loop proportion gain], [04: Speed loop integral gain], and [05: Speed loop derivative gain].

(5) If the alarm occurs when the actuator is in standalone mode (no load):

- ◆ Cause 1: The motor or encoder is connected incorrectly
⇒ Action: Correct the connection according to the instructions in “Chapter 4, Installing the HS-360 driver”.



Encoder failure (Alarm clear: Impossible)

● **Description**

This alarm occurs when the signal from the encoder stops. The only way to reset it is to examine the cause, and shut off and then turn on the power.

● **Possible causes**

(1) If the alarm occurs when the power is turned on:

- ◆ Cause 1: The encoder connector (CN2) is not connected, or the connection is faulty or disconnected.
⇒ Action: Reconnect the CN2 connector firmly, or check the wiring.
- ◆ Cause 2: Noise is included on the encoder cable.
⇒ Action: Check whether the connection of the encoder cable shielded wire is separated, and whether both the actuator and driver are grounded.
- ◆ Cause 3: A component in the encoder broke, or the driver is broken.
⇒ Action: Contact a business office of Harmonic Drive Systems.
(Replacing the actuator or driver)

(2) If the alarm occurs during operation: (normally restored by cooling the actuator)

- ◆ Cause 1: The encoder malfunctioned due to an actuator temperature rise.
⇒ Action: Reconsider the actuator instruction location and the cooling systems.



Regeneration failure (Alarm clear: Impossible)

● Description

This alarm occurs when an over power supply voltage is detected.
The only way to reset it is to examine the cause, and shut off and then turn on the power.

● Possible causes

(1) If the alarm occurs during deceleration:

- ◆ Cause 1: The ambient conditions of operation are severe.
⇒ Action: Recheck that the ambient conditions are not problematic in terms of the specifications.
(Increase the acceleration/deceleration time or quiescent time, if required)
- ◆ Cause 2: Insufficient capacity of regeneration
⇒ Action: A regeneration unit needs to be added.
Refer to "Section 10-6, Regeneration unit", and reconsider this action.



Pay sufficient attention to operation when rotating the actuator from the load side.

- If the driver is operated while the alarm is rotated from the load side, the driver may burn.



Overheat (Alarm clear: Possible)

● Description

This alarm occurs when the temperature of the HS-360 driver radiator plate exceeds the allowable temperature (75°C).
After the temperature decreases below the operation detection temperature, reset the alarm or power on the driver again.

● Possible causes

(1) If the alarm occurs when the power is turned on:

- ◆ Cause 1: HS-360 driver control circuit failure
⇒ Action: Contact a business office of Harmonic Drive Systems.
(Replacing the HS-360 driver)

(2) If the alarm occurs during operation (the operation can resume after a lapse of 4 to 5 min):

- ◆ Cause 1: Overloaded operation
⇒ Action: Reconsider the effective duty ratio of the actuator to decrease it.
- ◆ Cause 2: The ambient temperature of the HS-360 driver is higher than 50°C.
⇒ Action: Reconsider the actuator instruction location and the cooling system.

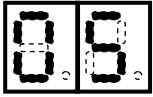

CPU failure (Alarm clear: Impossible)

● Description

This alarm occurs due to a driver CPU failure. It cannot be reset.

● Possible causes

(1) If the alarm occurs when the power is turned on:

- ◆ Cause 1: While the actuator is rotating, the driver is powered on due to an unknown cause.
 - ⇒ Action: Configure the system so that the actuator cannot rotate when the driver is powered on.
- ◆ Cause 2: HS-360 driver control circuit failure
 - ⇒ Action: Contact a business office of Harmonic Drive Systems.
(Replacing the HS-360 driver)

(2) If the alarm occurs during operation:

- ◆ Cause 1: Malfunction caused by external noise
 - ⇒ Action: Suppress the noise according to the instructions in “Section 4-4, Suppressing noise”.
- ◆ Cause 2: HS-360 driver control circuit failure
 - ⇒ Action: Contact a business office of Harmonic Drive Systems.
(Replacing the HS-360 driver)

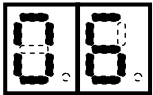

Over-current (Alarm clear: Impossible)

● Description

This alarm occurs when the maximum current, depending on the DC servo actuator model, is detected for 1ms or longer. The only way to reset it is to examine the cause, and shut off and then turn on the power.

● Possible causes

(1) If the alarm occurs when the power is turned on:

- ◆ Cause 1: HS-360 driver control circuit failure
 - ⇒ Action: Contact a business office of Harmonic Drive Systems.
(Replacing the HS-360 driver)

(2) If the alarm occurs when the input signal [CN1-5: S-ON] is input (ON):

- ◆ Cause 1: HS-360 driver control circuit failure
 - ⇒ Action: Contact a business office of Harmonic Drive Systems.
(Replacing the HS-360 driver)

(3) If the alarm occurs when the input signal [CN1-5: ENABLE] is input (ON), but normal operation is restored by removing the motor cables (+,-):

- ◆ Cause 1: Motor cable short circuit
⇒ Action: Inspect and reconnect or replace/repair the motor cables.
- ◆ Cause 2: Motor winding short circuit
⇒ Action: Contact a business office of Harmonic Drive Systems.
(Replacing the actuator)

(4) If the alarm occurs during acceleration or deceleration:

- ◆ Cause 1: Excessive moment of inertia of load and excessively short acceleration/deceleration time
⇒ Action: Decrease the moment of inertia of load.
- ◆ Cause 2: The gain is too high or low.
⇒ Action: Make the following adjustments according to the load: [Parameter setup mode] → [02: Position loop gain], [03: Speed loop proportion gain], [04: Speed loop integral gain], and [05: Speed loop derivative gain].

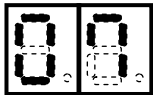
**Excessive error** (Alarm clear: Possible)**● Description**

This alarm occurs when the error counter value reaches or exceeds the pulse count being set for [00: Transmission error allowance] of [Parameter setup mode]. It can be reset by inputting the signal to [CN1-7 Error counter clear: CLEAR] or [CN1-6 Alarm reset: ALM-RST]. The error counter is also cleared at the same time.

● Possible causes**(1) If the alarm occurs when the power is turned on:**

- ◆ Cause 1: HS-360 driver control circuit failure
⇒ Action: Contact a business office of Harmonic Drive Systems.
(Replacing the HS-360 driver)

(2) If the alarm occurs during acceleration or deceleration:

- ◆ Cause 1: Excessive moment of inertia of load
⇒ Action1: Try to decrease the moment of inertia of the load.
⇒ Action2: Increase or decrease the command pulse frequency of the higher-level system.
- ◆ Cause 2: The [Area of excessive error] or [Gain] value of [Parameters] is too small.
⇒ Action: Extend [Area of excessive error]. Alternatively, make the following adjustments according to the load: [Parameter mode] → [02: Position loop gain], [03: Speed loop proportion gain], [04: Speed loop integral gain], and [05: Speed loop derivative gain].
- ◆ Cause 3: [Command pulse frequency] is too large.
⇒ Action: Decrease the [Command output pulse frequency] setting of the higher-level system.

(3) If the speed does not increase according to the command and the alarm occurs after a while:

- ◆ Cause 1: One or more encoder or motor cables are disconnected.
⇒ Action: Check whether the encoder and motor cable are connected properly.

(4) If the alarm occurs due to a failure in the external mechanical system:

- ◆ Cause 1: A mechanical-system failure disabled the rotation of the actuator, which attempted to perform the rotation in response to the command pulse input. As a result, the error pulse exceeded the allowance.
⇒ Action: Remove the obstacle from the mechanical system.

**IPM failure** (Alarm clear: Impossible)**● Description**

This alarm occurs when the IPM does not operate normally. The only way to reset it is to turn on the power.

● Possible causes**(1) If the alarm occurs when the power is turned on:**

- ◆ Cause 1: A motor wire has been earth fault.
⇒ Action: Ensure that motor wires are not earth fault.
- ◆ Cause 2: HS-360 driver circuit failure
⇒ Action: Contact a business office of Harmonic Drive Systems.
(Replacing the HS-360 driver)

(2) If the alarm occurs during operation:

- ◆ Cause 1: A device of the HS-360 driver control circuit malfunctioned.
⇒ Action: Contact a business office of Harmonic Drive Systems.
(Replacing the HS-360 driver)

In addition, check whether the ambient conditions of the instruction location contain no inappropriate point. Do this according to the instructions in "Section 4-3, Location and installing".

- ◆ Cause 2: Short circuit of actuator motor winding
⇒ Action: Contact a business office of Harmonic Drive Systems.
(Replacing the actuator)

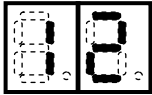

Over-speed (Alarm clear: Possible)

● Description

The alarm occurs when the motor revolution speed exceeds the motor speed limit plus 10r/min for 0.5s. This alarm can be reset.

● Possible causes

(1) If the alarm occurs when the power is turned on:

- ◆ Cause 1: The forcible rotation to the actuator output shaft is faulty.
⇒ Action: If the rotation takes place with the external force applied to the actuator output shaft, modify the equipment so that this rotation cannot take place.
- ◆ Cause 2: Disconnection or wiring failure of encoder cable
⇒ Action: Check the encoder cables and their wiring.
- ◆ Cause 3: HS-360 driver control circuit failure
⇒ Action: Contact a business office of Harmonic Drive Systems.
(Replacing the HS-360 driver)

(2) If the alarm occurs when input of a rotation command causes high-speed rotation of the actuator:

- ◆ Cause 1: Rapid raising of [Command pulse frequency]
⇒ Action: Set an earlier raising time point.
- ◆ Cause 2: Large overshoot caused by improper gain adjustment
Make the following adjustments so that the raising time matches the load: [Parameter setup mode] → [02: Position loop gain], [03: Speed loop proportion gain], [04: Speed loop integral gain], and [05: Speed loop derivative gain].

Chapter 9 Troubleshooting procedure and action

This chapter details the troubleshooting procedure and action flow for actuator operation failures other than the alarms. It consists of the following sections:

- 9-1 No rotation
- 9-2 Unusable rotation
- 9-3 Poor positioning accuracy

Note: In the flowcharts, "Y" and "N" represent "Yes" and "No", respectively.

9-1 No rotation of actuators

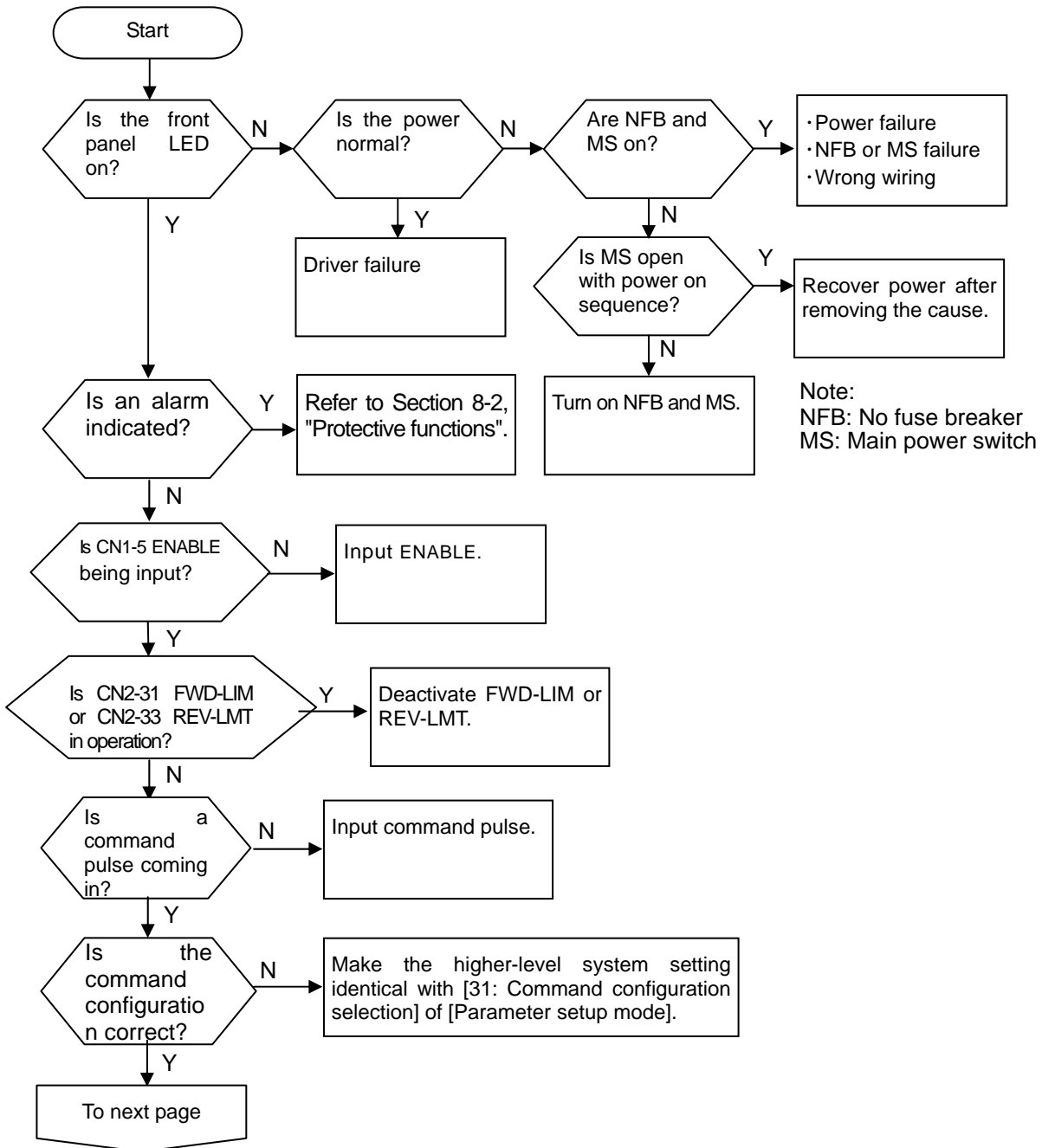

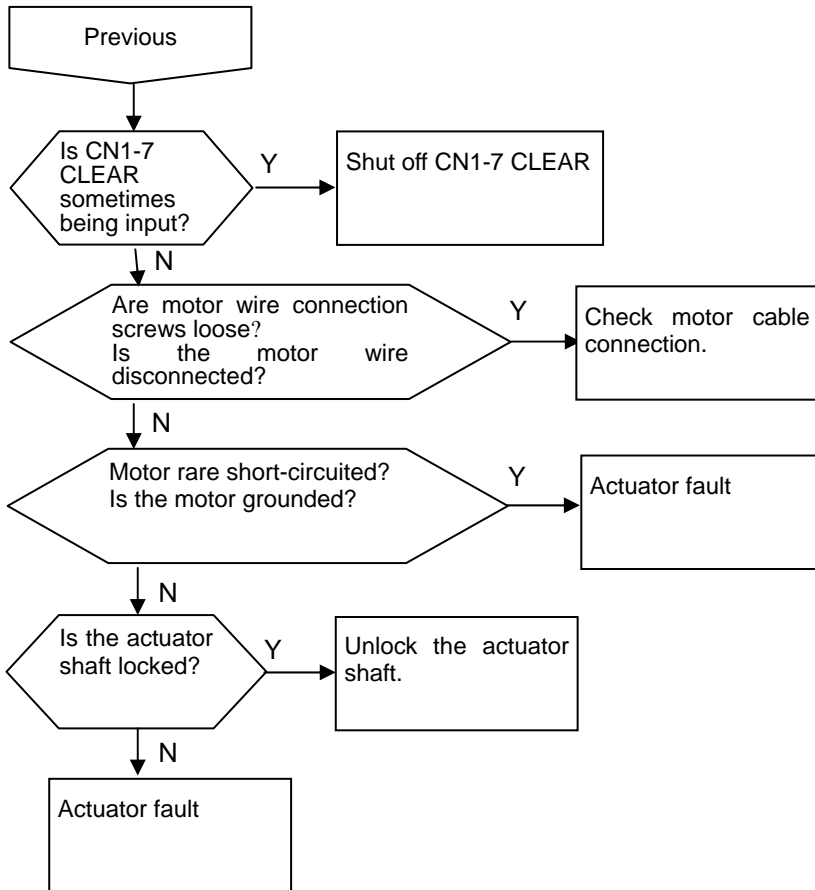

9-2 Unstable rotation of actuator

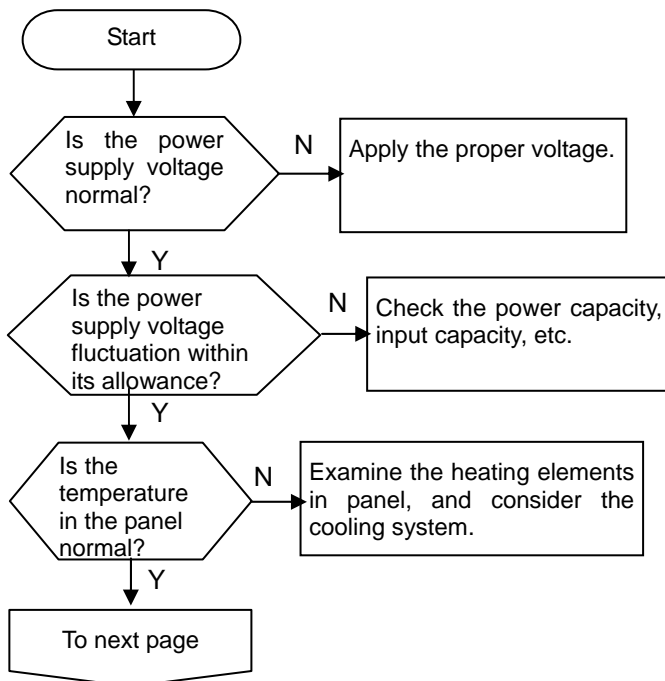

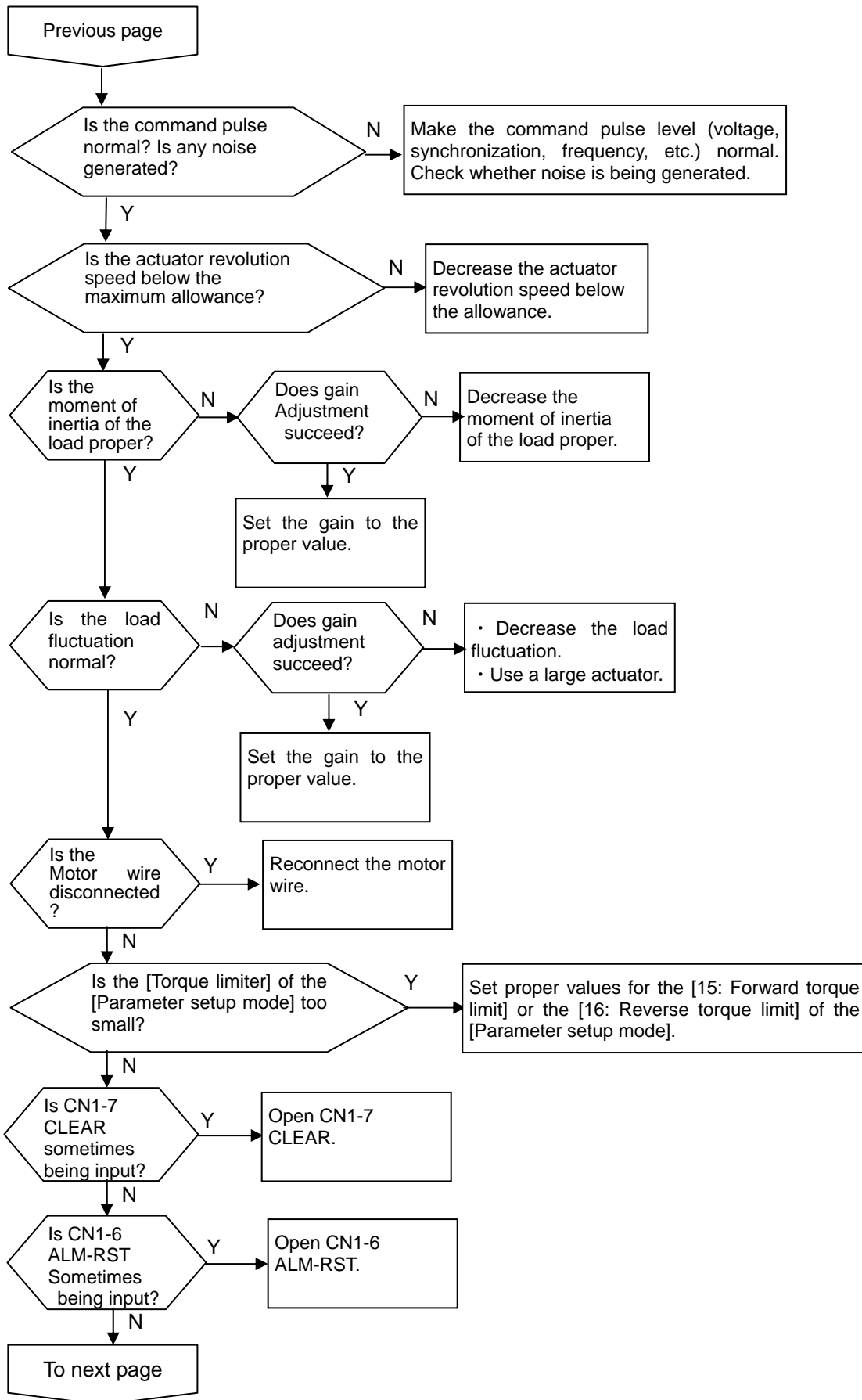

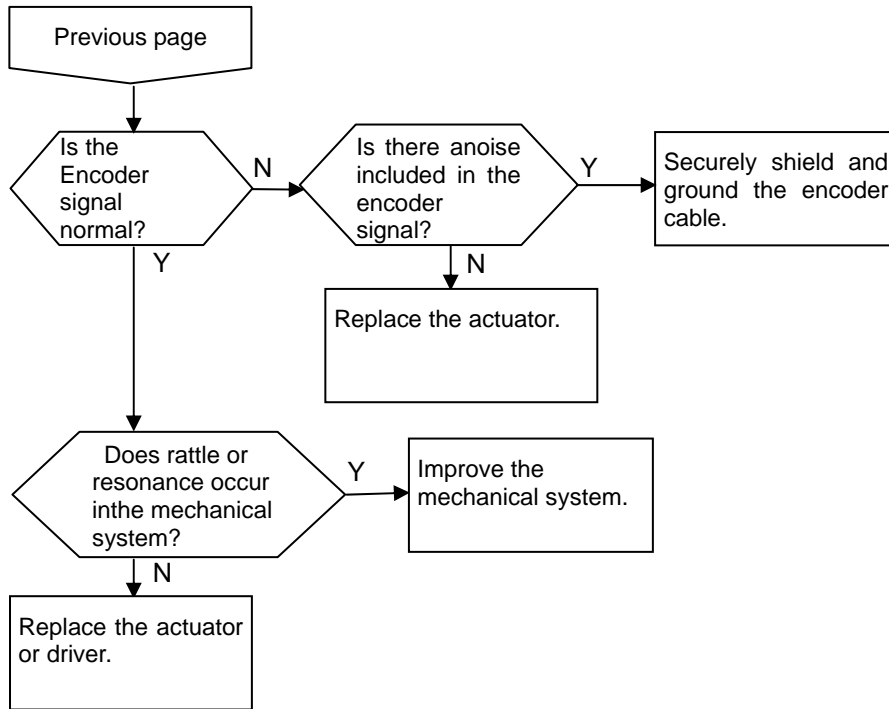

9-3 Poor positioning accuracy

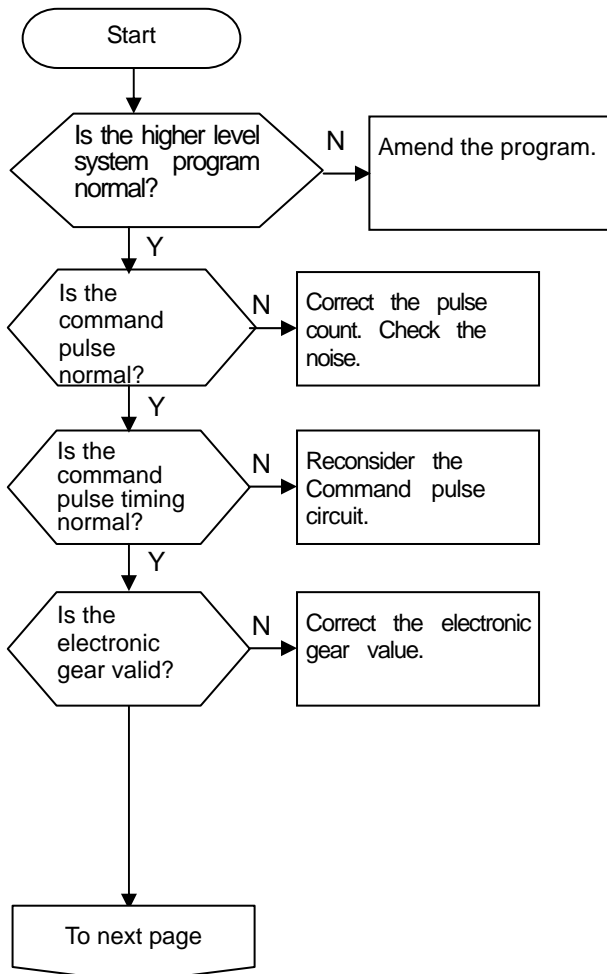

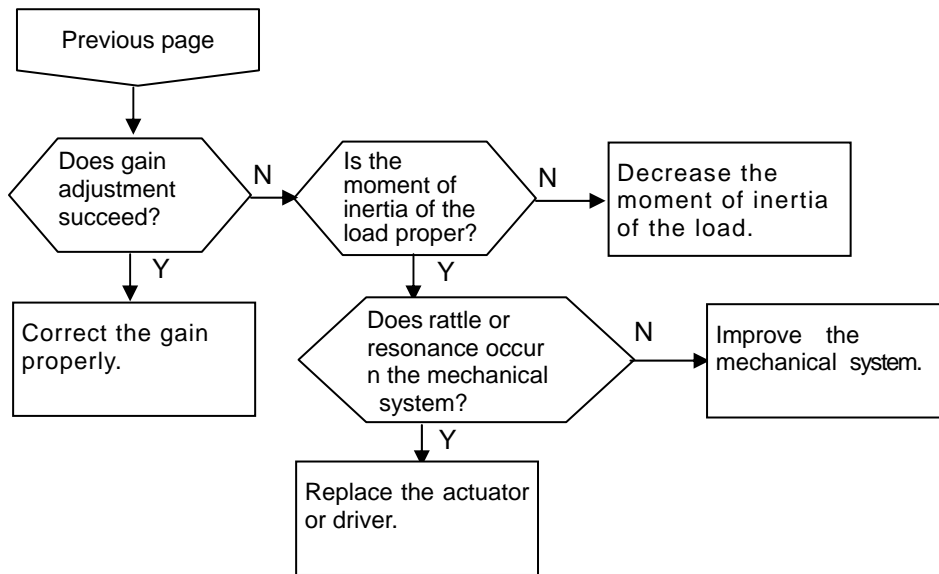

INDEX

1 pulse train	11,54
2-pulse train	11,19,20,54
Multiplication of 2-phase pulse	44,56
2-phase pulse train	11,54,56
A-B phase pulses with 90-degree difference	11
A-A	8
ALARM	7,16,40,55,59
ALM-RST	7,13,54
Phase-A input	8
Phase-A reversal input	8
B · B	8,18
Phase-B input	8
Phase-B reversal input	8
CLEAR	7,13,40,55
CLEAR signal function selection	44,56
CN1	5,7,10,12,15,30
CN2	6,8,17,18,30
CN3	6,9
CN4	6
CTS	9,73
DATA key	5,37,38,39,41
DOWN key	5,37,38
DSR	9,73
DTR	9,73
E	7,27,29
EIA232C	6,9,57,73
EGP-0V	8
EPG-Vcc	8
FG	7,8,9
FWD+	7,10,11
FWD -	7,10,11
FWD-LMT	8,14,40,54
FWD and REV pulse train	11
FWD operation pulse (+)	7
FWD operation pulse (-)	7
IN-COM	7,12,13
IN-POS	7,15,16,40
IPM failure	59,65
JOG operation mode	36,41
JOG operation	41
JOG character-S selection	42,44,57
JOG acceleration/deceleration time constant	42,44,56
JOG feed pulse count	42,44,51
JOG operation speed	42,44,51
LED display segment	5
LMT-VCC	8
LMT signal power supply	8,14
MODE key	5,36,38,39,41
MON-A	8
MON-B	8
MON-Vcc	8
MON-0V	8
MON-Z	8
N	7,27,28
OUT-COM	7,15
P	7,27,28
PG-0V	8,18
PG-VCC	8,18
POS-OVR	40
POW-ON	37,40
PSF-520	9,73
R	7,27,28
READY	7,15,40
REV+	7,10,11
REV -	7,10,11
REV-LMT	8,14,40,51,55
REV operation pulse (+)	7
REV operation pulse (-)	7
RS-232C-compliant	6,9
RS-232C communication cable	9,73
RTS	9
V-ON	37,40
RXD	9
ENABLE	7,13,37,40,54
SPD-LMT	37,40
T	7,27,28
TB	7,16
TB2	6,7
TRQ-LMT	37,40
TXD	9
UP key	5,37,38
VOL-OVR	37,40
Z · Z	8,18
Z-IZ	7,15,16
Phase-Z input	8
Phase-Z reversal input	8
Actuator cable	29
Actuator connection terminal	6,7
Reset an alarm	37
Alarm reset	7,12,13
Alarm output	7,12,16
Alarm display	37
Clear the alarm history	37
Display the alarm history	37
In-position	7,15,16
In-position range	44,45
Position loop gain	44,45,46
Operation	32
Ready	7,15
Encoder +5V power supply	8
Encoder Phase-Z	7,16
Encoder failure	59,61
Encoder, external power supply	8
Encoder, external power supply common	8
Encoder cable	30
Encoder connector	6,8,30
Encoder power supply common	8
Encoder input	18
Encoder monitor Phase-A output	8,17
Encoder monitor Phase-B output	8,17
Encoder monitor Phase-Z output	8,17
Encoder monitor output	3,17
Encoder monitor 5V power supply	8,17
Encoder monitor power supply common	8,17
Open collector command	10,20
External dimensions	4
Regeneration failure	59,62
Regeneration brake on/off	44,58
Regeneration unit connection terminal	7,28
Rotary direction command	44,48
External regeneration unit connection terminal	6
External I/O connector	5,7,30
Over-speed	59,66

Acceleration feed forward factor	44,48	Speed feed forward factor	44,47
Model	2,21	Speed loop integral gain	44,47
Over-current	59,63	Speed loop derivative gain	44,47
Overheat	59,62	Speed loop proportional gain	44,46
Overload	59,60	2nd Position loop gain	44,53
Feedback pulses count	39,43	2nd Speed loop proportional gain	44,53
Reverse inhibit	8,14	2nd speed loop integral gain	44,53
Reverse torque limit	44,50	2nd Control switching range	44,53
Position error allowance	40,43,44,45,	Dynamic brake on/off	13,44,58
Current speed	39	Data Set Ready	9
Structure/installing procedure	3	Data Terminal Ready	9
Troubleshooting	67	Charge voltage monitor	5,34
Circuit breaker	28	Clear to send	9
Circuit protector	28	Communication condition setting	44,57
Servo on	7,13	Rated output current (rms)	3
Servo state display	37	Stop cause display	39,40
Servo parameters setup software	73	Applicable position sensor	3
Maximum output current (rms)	3	Power supply terminal	6,7
Maximum input pulse frequency	3	Power cable	27
Trial run	32	Power supply voltage	22, 44,54
Signal ground	9	Power on sequence	31
System failure	59,63	Power loss	23
Effective duty ratio	39	Accessories	21
Shutoff sequence	31	Torque command filter	44,48
Ambient conditions	3	Torque command	39
Receive data	9	Torque step correction	44,50
Output signal common	7,15	Torque peak	39
Output pin logic setting (bit)	44,55	Built-in circuit	3
Service temperature	3,23	Built-in functions	3
Impact	23	I/O state display	39,40
Service humidity	3,23	I/O signal cable	30
State display mode	36,37	Input signal	12,13
Service power supply	3	Input signal common	7,13
Serial interface	3	Input pin logic setting (bit)	44,55
Serial port connector	6,9	Action against noise	24
Command speed	39	Noise filter	25,28
Command pulse frequency	39	Parameters	44
Cause pulse count	39,43	Parameter setup mode	36,38
Command pulse input	10	Pulse output configuration	19,20
Electronic gear-numerator	44,49	Non-connection terminal	7
Electronic gear-denominator	44,49	Display panel component names	5
Command pulse input configuration	44,54	Code plus pulse train	11
Vibration	23	Frame ground	7,8,9
Numeric monitor mode	36,39	Error counter reset	7,14
Control function	3	Excessive error	59,64
Control output signal	3	Error pulse count	39,43
Control state display	39,40	Protective functions	3,59
Control I/O	10,12	Maintenance	34
Control I/O connector	6	Usual operation	34
Control I/O signal	3	Nameplate	21
Control input filter time constant	44,53	Memory failure (EEPROM)	59,60
Control method	3	Monitor	3
Forward inhibit	8,14	Line driver command	10,19
Forward torque limit	44,50		
Isolation transformer	28,74		
Connector	28,72		
Grounding terminal	6,7,29		
Installing	23,24		
Grounding	24		
Ground wire cable	27,29		
Location	23		
Operations	32		
Transmit data	9		
Request to transmit	9		
Speed step correction	44,49		
Speed limit	44,57		

Warranty Period and Terms

The HS-360 series servo drivers are warranted as follows:

■ Warranty period

Under the condition that the actuator are handled, used and maintained properly followed each item of the documents and the manuals, all the HS-360 series drivers are warranted against defects in workmanship and materials for the shorter period of either one year after delivery or 2,000 hours of operation time.

■ Warranty terms

All the HS-360 series drivers are warranted against defects in workmanship and materials for the warranted period. This limited warranty does not apply to any product that has been subject to:

- (1) user's misapplication, improper installation, inadequate maintenance, or misuse.
- (2) disassembling, modification or repair by others than Harmonic Drive Systems, Inc.
- (3) imperfection caused by the other than the HS-360 servo driver.
- (4) disaster or others that does not belong to the responsibility of Harmonic Drive Systems, Inc.

Our liability shall be limited exclusively to repairing or replacing the product only found by Harmonic Drive Systems, Inc. to be defective. Harmonic Drive Systems, Inc. shall not be liable for consequential damages of other equipment caused by the defective products, and shall not be liable for the incidental and consequential expenses and the labor costs for detaching and installing to the driven equipment



Certified to ISO14001 (HOTAKA Plant) / ISO9001 (TÜV Management Service GmbH)
All specifications and dimensions in this manual subject to change without notice.

	<p>Head Office: Believe Omori 7F 6-25-3 Minami-Ohi, Shinagawa-ku, Tokyo, Japan 140-0013 TEL +81-(0)3-5471-7800 FAX +81-(0)3-5471-7811</p> <p>Overseas Division: Believe Omori 7F, 6-25-3 Minami-Ohi, Shinagawa-ku, Tokyo, Japan 140-0013 TEL +81-(0)3-5471-7800 FAX: +81-(0)3-5471-7811</p> <p>Hotaka Plant: 1856-1 Maki, Hotaka, Azumino-shi, Nagano, Japan 399-8305 TEL +81-(0)263-83-6800 FAX +81-(0)263-83-6901</p> <p>Harmonic Drive AG: Hoenbergstrasse 14 D-65555 Limburg a.d. Lahn Germany TEL +49-6431-5008-0 FAX +49-6431-5008-18</p> <p>Harmonic Drive L.L.C.: 247 Lynnfield Street, Peabody, MA, 01960, U.S.A. TEL 978-532-1800 FAX 978-532-9406</p>
--	--------------------------------------------------------------------------------------------------------------------------------------------------------------------------------------------------------------------------------------------------------------------------------------------------------------------------------------------------------------------------------------------------------------------------------------------------------------------------------------------------------------------------------------------------------------------------------------------------------------------------------------------------------------------------------------