

NOTICE TO USE "FHA / RS / RKS / RJ / MAA Series" Actuators and Motors, "HA Series" Control Units, "RH / RHS / RFS Series" Actuators, and "HS Series" Control Units, "RP Series Actuators, and "UDX Series" Driver, "LA / LAH / LNP / LBC Series" Linear Actuators



## SAFETY GUIDES



**WARNING:** Indicates precaution that could possibly result in loss of human life or serious physical injury by unheeded usage.



**CAUTION:** Indicates precaution that could result in relatively serious or minor physical injury, or damage to the product by unheeded usage.

### LIMITATION OF APPLICATIONS:

We restrict not to use the equipment listed in this document for the applications as follows:



Space equipment	Automobile, automotive parts
Aircraft, aeronautic equipment	Amusement equipment, sport equipment, game machines
Nuclear equipment	Machines or devices acting to human body directly
Household apparatus	Vehicles or apparatus to carry human body
Vacuum equipment	Apparatus or devices used in special environment

When your application for the products will be expected of at least one of above, consult us before your planning.





**You must install sufficient safety measures to the applied equipment to prevent an accident resulting in loss of human life, or serious physical injury or a damage by a malfunction or miss operation.**

### NOTICES TO USE AN ACTUATOR

Notices for designing an application: Always read the relating technical documents for the purpose.

 <p><b>Caution!</b></p> <p>Always use the actuators and motors in the specified environment.          *Use the actuators and motors with the following indoor conditions:          -Ambient temperature: 0°C to 40°C          -Ambient humidity: 20% to 80%RH (Non condensation)          -Vibration: Less than 24.5 m/S<sup>2</sup>          -No water or oil drips          -No corrosive gas or no explosive gas</p>	 <p><b>Caution!</b></p> <p>Install the actuator or the motor with the applied equipment precisely following the relating instruction manuals.          -Align the shaft of actuator or the motor with the applied equipment properly following the relating instruction manual.          -If the alignment is not precise, vibration will occur, resulting in damage to the bearings.</p>
------------------------------------------------------------------------------------------------------------------------------------------------------------------------------------------------------------------------------------------------------------------------------------------------------------------------------------------------------------------------------------------------------------------------------------------------------------------------------------------------------------------------------------	--------------------------------------------------------------------------------------------------------------------------------------------------------------------------------------------------------------------------------------------------------------------------------------------------------------------------------------------------------------------------------------------------------------------------------------------------------------------------------------





Notices for operation: Always read the relating operation manual and technical documents for the purpose.

 <p><b>Caution!</b></p> <p>Do not apply torque exceeding the actuator's or motor's maximum torque.          -When a load-arm attached to the actuator directly, output rotation might become uncontrolled by an accident that the load-arm hit something.</p>	 <p><b>Caution!</b></p> <p>Do not plug actuators or motors directly to the commercial power supply.          -An actuator or a motor cannot run without paired control unit.          -Direct connection to the commercial power supply will damage the actuator or motor, and may cause fire.</p>
 <p><b>Caution!</b></p> <p>Do not hit actuators or motors.          -As an actuator or a motor houses an encoder, do not hit it with a wooden hammer or others.          -When an encoder is fault, the actuator or the motor runs uncontrollably</p>	 <p><b>Caution!</b></p> <p>Do not pull lead wires.          -Pulling lead wires will damage wire connections, causing uncontrolled rotation.</p>

## NOTICES TO USE A CONTROL UNIT





### Notices for designing an application

Always read the relating technical documents for the purpose.

 <p><b>Caution!</b></p> <p>Always use the control units in the specified environment.</p> <p>* A control unit generates heat. Install the control unit so that it can radiate heat freely under the following conditions:</p> <ul style="list-style-type: none"> <li>-Install it with vertical orientation having enough space from other devices.</li> <li>-Ambient temperature: 0°C to 50°C</li> <li>-Ambient humidity: less than 95%RH (Non condensation)</li> <li>-No vibration, no shock</li> <li>-No corrosive gas, no explosive gas, no dust, or no powder</li> </ul>	 <p><b>Caution!</b></p> <p>Make sufficient noise suppression and grounding.</p> <p>* Electric noise on a signal wire may cause result in unit malfunction or unexpected occurrence of troubles. Keep the following conditions:</p> <ul style="list-style-type: none"> <li>-Separate signal wires from power lines.</li> <li>-Make electric wires short as much as possible.</li> <li>-Actuators and control units should be grounded at one single point having grounding resistance class 3 or more.</li> <li>-Do not use a power line filter into motor circuit.</li> </ul>
 <p><b>Caution!</b></p> <p>Do not apply overhung-load to actuators or motors.</p> <p>* Overhung load on an actuator or a motor may damage a control unit.</p> <ul style="list-style-type: none"> <li>-Consult to our sales organization regarding this.</li> </ul>	 <p><b>Caution!</b></p> <p>Use a fast-response type ground-fault detector designed for PWM inverters.</p> <p>* Do not use a time-delay-type ground-fault detector.</p>

### Notices for operation:

Always read the relating operation manual and technical documents for the purpose.

 <p><b>Warning!</b></p> <p>Do not change wiring whenever power supply is active.</p> <p>* Turn power OFF at first, then disconnect or connect connectors or wires.</p> <p>* Getting an electric shock or abnormal damage may occur by changing wire during power active.</p>	 <p><b>Warning!</b></p> <p>Do not touch a terminal after at least three minutes from power-OFF.</p> <p>* Even after power-OFF, electric charge remains in the control unit. To avoid an electric-shock-accident, inspection must start after three minutes from power-OFF.</p> <p>* The control unit should be housed in a cabinet box designed not to touch electric parts easily.</p>
 <p><b>Caution!</b></p> <p>Do not make a withstanding voltage test.</p> <p>* Do not make a withstand test or a voltage resistance test. The test causes damage to the control unit.</p>	 <p><b>Caution!</b></p> <p>Do not operate an control unit by means of power ON/OFF operation.</p> <p>* The frequent power ON/OFF operation may cause deterioration of the electronic elements.</p> <p>* Start/stop operation should be performed by means of input signals.</p>

### Abandonment of an actuator, a motor, a control unit and their parts:

 <p><b>Caution!</b></p> <p>Abandon an actuator, and a motor, a control unit and their parts as industrial waste.</p>	
---------------------------------------------------------------------------------------------------------------------------------------------------------------------------------------------------------	--

# CONTENTS

1.	ABSTRACT .....	5
2.	HOW TO ORDER .....	5
3.	EXTERNAL VIEW .....	6
4.	SPECIFICATIONS .....	7
4.1	ACTUATOR SPECIFICATIONS .....	7
4.2	ENCODER SPECIFICATIONS .....	8
5.	ACCURACY .....	9
6.	TESTING SYSTEM AND STANDARDS FOR TESTING .....	10
6.1	TESTING SYSTEM .....	10
6.2	STANDARD FOR TESTING .....	11
7.	MECHANICAL CHARACTERISTICS .....	13
7.1	ALLOWABLE LOADS .....	13
7.2	AXIAL STIFFNESS OF OUTPUT ROD .....	13
7.3	IMPACT .....	13
7.4	VIBRATION .....	13
7.5	LIFE .....	14
8.	NOTICES AT SYSTEM DESIGN AND ON USAGE .....	14
8.1	ENVELOPMENT .....	14
8.2	INSTALL DIRECTION .....	14
8.3	LOAD DIRECTION .....	15
8.4	NOTICES AT DRIVING .....	15
8.5	STROKE LIMITS AND ROD POSITION AT SHIPPING .....	15
8.6	LIMIT SWITCHES .....	16
8.7	RELATIONSHIP BETWEEN INPUT SIGNAL AND ACTUATOR MOTION .....	16
9.	CONNECTIONS .....	17
9.1	MOTOR CONNECTION AND MOVING DIRECTION .....	17
9.2	COLOR OF ENCODER LEADS .....	17
9.3	TREATMENT OF ENCODER LEAD .....	17
9.4	MOTOR LEAD EXTENSION .....	17
9.5	ENCODER LEAD EXTENSION .....	17
10.	CONTROL UNIT .....	21
11.	TRIAL OPERATION .....	23
12.	STORING .....	23
12.1	STORING PLACE .....	23
12.2	ANTI-CORROSION .....	23
12.3	STORING POSTURE .....	23

# 1. Abstract

The LAH series actuators (DC motor model) are linear actuators incorporating a precise ball screw, a DC motor for closed-loop positioning, and a Harmonic drive® component having small size, high precision, and no backlash. With a dedicated control unit, the actuators offer remarkable preciseness in positioning and the smoothest motion from top speed to extremely low speed responding to input signals.

## Features:

- Ultra-high positioning accuracy in sub-micron-meter-meter order
- High repeatability in positioning
- High thrust, small size
- Closed-loop positioning
- Low vibration, No skip step, Low heat radiation
- Long travel

## 2. How to order

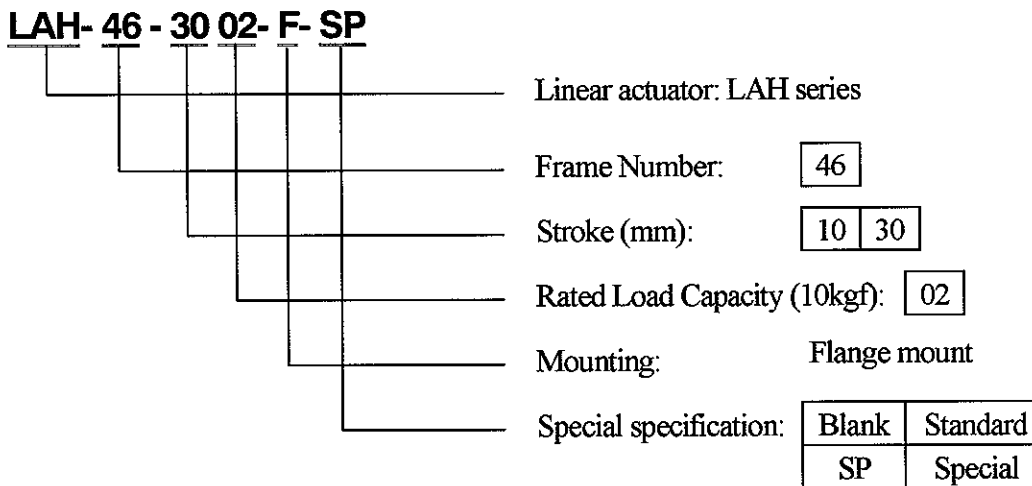

### 3. External view

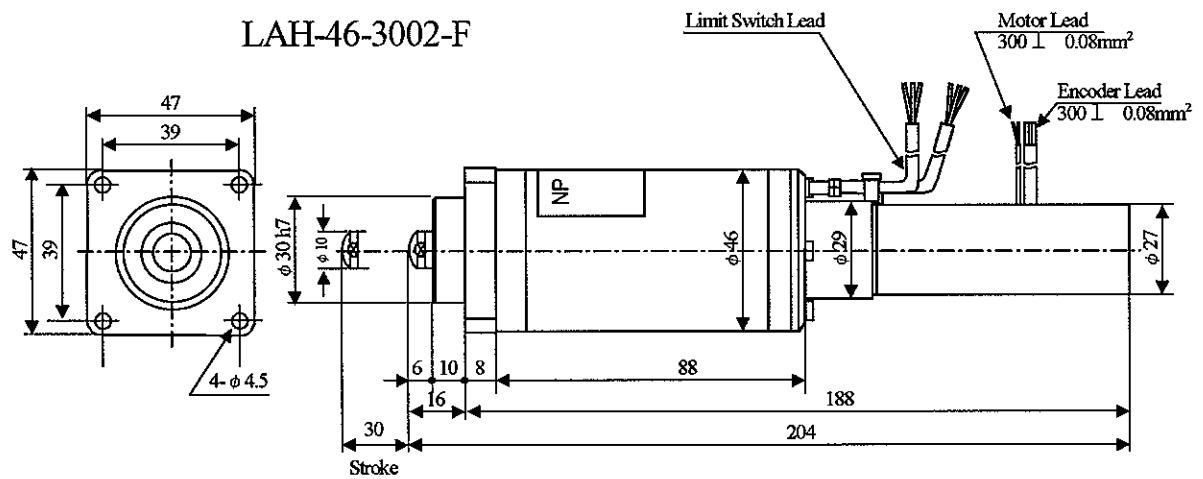
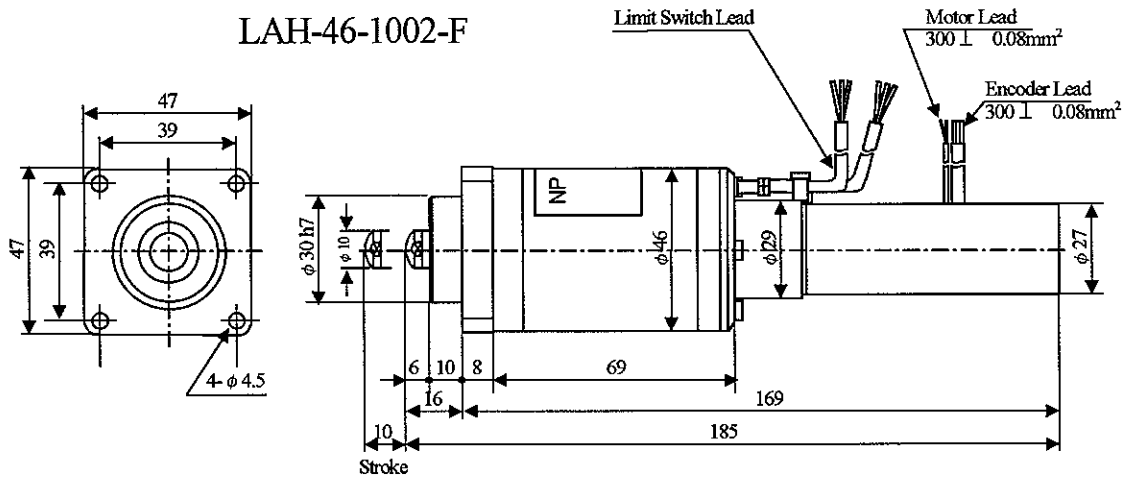

## 4. Specifications

### 4.1 Actuator specifications

Specifications		Models	
		LAH-46-1002-F	LAH-46-3002-F
Resolution per encoder pulse		0.069 $\mu$ m	
Stroke		10 mm	30 mm
Rated speed		2 mm/sec	
Maximum speed		3.7 mm/sec	
Rated load capacity		20 kgf (196N)	
Maximum load capacity		40 kgf (392N)	
Motor	Rated voltage	DC 12V	
	Rated current	0.5 A	
	Excitation	Permanent Magnet	
	Insulation class	B class	
	Withstand voltage	AC 500V, 1 minute	
	Insulation resistance	DC 500V 10M $\Omega$ or more	
	Enclosure	Totally Enclosed	
Ambient temperature		10°C to 25°C	
Lubrication		Grease	
Storage temperature		-20°C to +50°C	
Mass		0.81 kg	0.85 kg

## 4.2 Encoder specifications

Signal output	Open collector
Resolution	360 pulses/rev
Output channel	3 channels (A, B, Z)
Power supply	DC5V, $\pm 5\%$ , 60mA Max.
Output level	$V_{OL} \leq 0.5V$
Output current	$I_{OL} \leq 20\text{ mA}$
Signal power supply	$+5V \leq V_{CC} \leq +15V$
Allowable signal voltage	36VDC Max.
Signal rise time	$1\ \mu\text{S}$ Max. ( $R_L=1k\ \Omega$ )
Signal fall time	$1\ \mu\text{S}$ Max. ( $R_L=1k\ \Omega$ )
Max. response frequency	60 kHz
Light source	LED

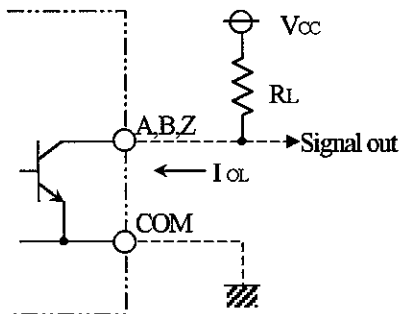
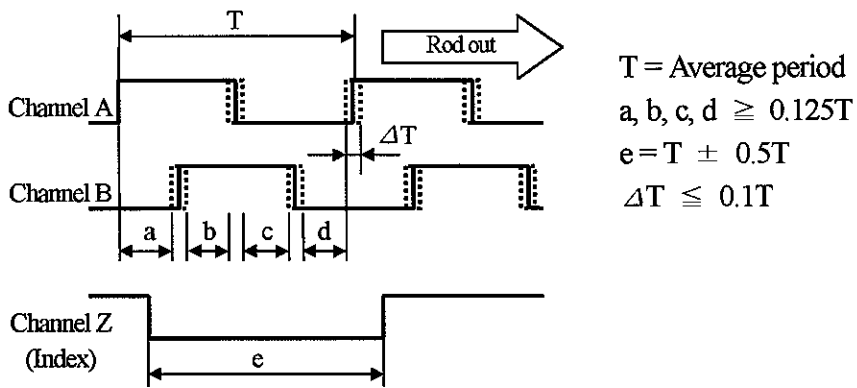

$V_{CC} = +5\text{ V to } +15\text{ V}$   
 $I_{OL} = 20\text{ mA Max.}$

## 5. Accuracy

Accuracy	Stroke	Model	
		LAH-46-1002-F	LAH-46-3002-F
Repetitive accuracy	1 mm	$\pm 0.5 \mu\text{m}$ or less	$\pm 0.5 \mu\text{m}$ or less
Full stroke positioning accuracy	Full stroke 0.2mm pitch	$7 \mu\text{m}$ or less for 10mm	$10 \mu\text{m}$ or less for 30mm
Short stroke positioning accuracy	Stroke: 0.2mm 0.002mm pitch	$4 \mu\text{m}$ or less for 0.2mm travel	$4 \mu\text{m}$ or less for 0.2mm travel
Lost motion	1 mm	$0.5 \mu\text{m}$ or less	$0.5 \mu\text{m}$ or less

Note. Measuring temperature:  $20^{\circ}\text{C} \pm 1^{\circ}\text{C}$

## 6. Testing system and standards for testing

### 6.1 Testing system

The LAH series linear actuators are guaranteed with the following tests under JIS B6201 standard using our original measuring system.

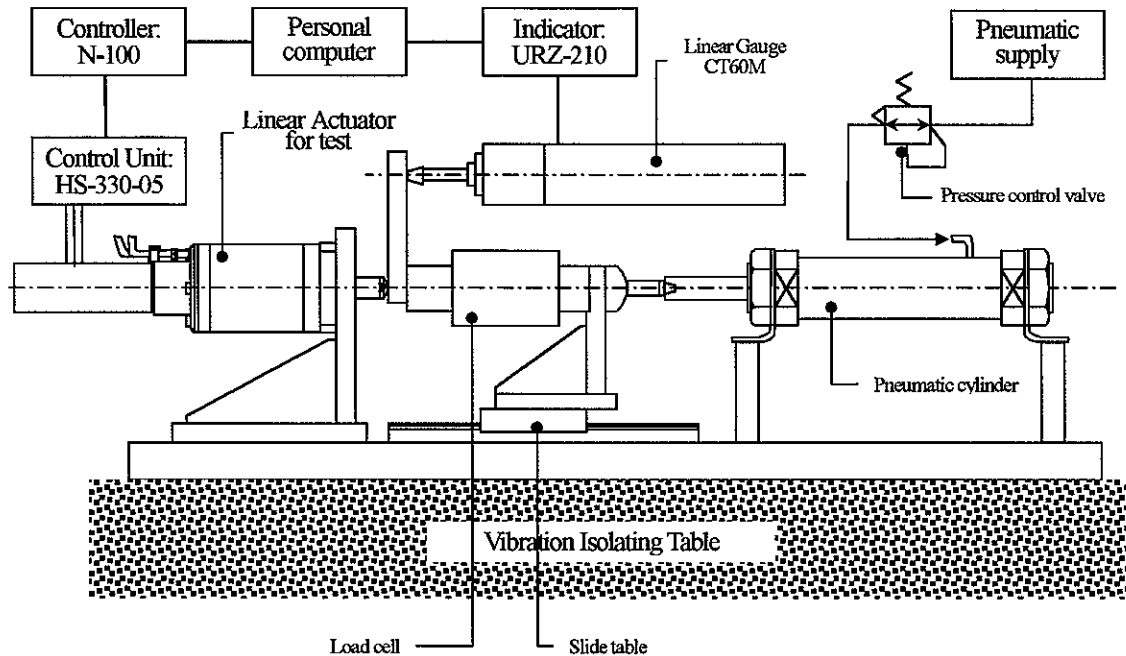

#### Main instruments:

Linear gauge: Hydenhein CT60M (Accuracy:  $\pm 1 \mu\text{m}$ )  
Indicator: Hydenhein URZ-210  
Control unit: Harmonic drive® HS-330-05  
Controller: Japan pulse Co. N-100  
Personal Computer

## 6.2 Standard for testing

### (1) Repetitive positioning accuracy

- A. Actuator rod moves toward pushing direction until the stroke center.
- B. The rod moves 1mm toward pushing direction. The position is named [A1].
- C. The rod draws 1mm toward pulling direction, and the position is measured. The position is named [P1].
- D. The rod moves 1mm toward pushing direction [A2]. Then it draws 1mm toward pulling direction, and the position is measured. The position is named [P2].
- E. Above push-pull motion is repeated seven times in total. Then seven positions [P1, P2, ..., P7] are measured.

The repetitive accuracy is obtained as a half of difference from the maximum measured value to the minimum value.

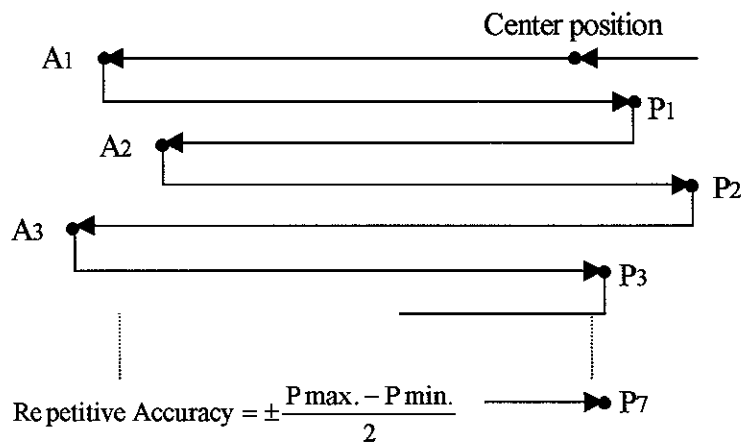

### (2) Full stroke positioning accuracy

- A. Actuator rod moves toward pulling direction until the stroke end. Then it rod moves 1mm toward pushing direction. The position is assigned to "Base position".
- B. Form the base position, the rod moves pushing direction by 0.2mm pitch measuring every position to come to the full stroke position.
- C. Position errors are calculated for every position by subtracting the actual position value from its ideal value.

The full stroke positioning accuracy is obtained as the difference of the maximum error and the minimum error.

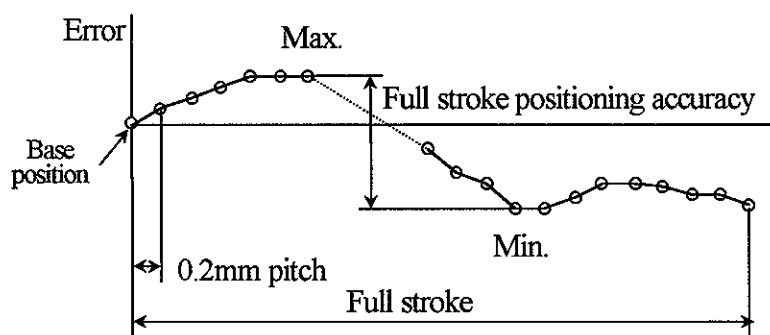

$$\text{Full stroke positioning accuracy} = \text{Maximum error} - \text{Minimum error}$$

(3) Short stroke positioning accuracy

- A. Actuator rod moves toward pushing direction until the stroke center. The position is assigned to "Base position".
- B. Form the base position, the rod moves pushing direction 100 steps by 0.002mm pitch measuring every position. (Total measuring range is 0.2mm.)
- C. Position errors are calculated for every position by subtracting the actual position value from its ideal value.

The full stroke positioning accuracy is obtained as the difference of the maximum error and he minimum error.

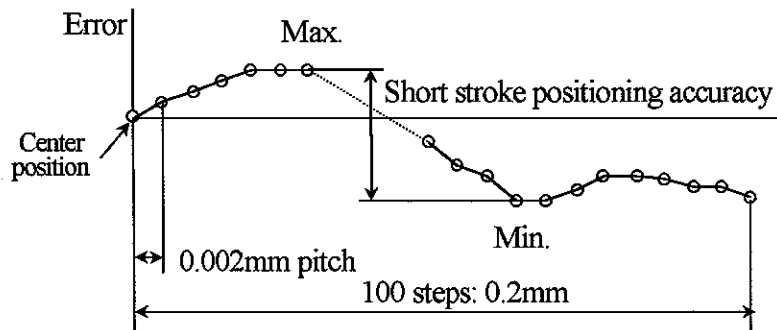

Short stroke positioning accuracy = Maximum error – Minimum error

(4) Lost motion

- A. Actuator rod moves toward pushing direction until the stroke center. The position is named [A0].
- B. Form [A0], the rod moves 1mm toward pushing direction. The position is named [A1].
- C. The rod draws 1mm toward pulling direction, and the position is measured. The position is named [P1].
- D. The rod draws 1mm toward pulling direction [A1'] in succession.
- E. Then it moves 1mm toward pushing direction, and the position is measured. The position is named [P1'].
- F. Above push-pull motion is repeated seven times in total. Then seven pairs of positions (P1, P1', P2, P2', ..., P7, P7') are measured. The lost motion is obtained as the difference between the average of [P1, P2, ..., P7] and [P1', P2', ..., P7'].

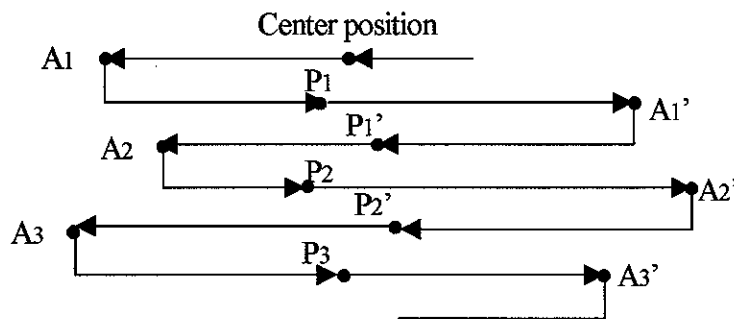

$$\text{Lost Motion} = \left| \frac{(P_1 + P_2 + \dots + P_7) - (P_1' + P_2' + \dots + P_7')}{7} \right|$$

## 7. Mechanical characteristics

### 7.1 Allowable loads

Allowable loads to the output rod are as follows:

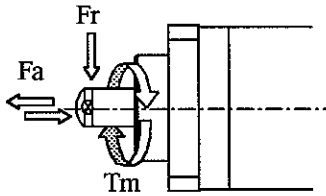

Load	Allowance
Fa: Axial Load	40kgf or less
Fr: Side Load	Inhibited
Tm: Rotary Torque	5 kgf·cm or less

### 7.2 Axial stiffness of output rod

The axial stiffness of the output rod is around 1.4 kgf/ $\mu$ m.

### 7.3 Impact

When the actuator installed horizontally and impacted to the side face, the actuator withstands impact of 50G (acceleration) three times. Do not apply any impact in axial direction.

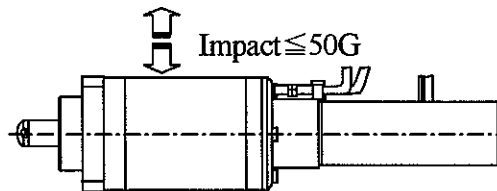

### 7.4 Vibration

When the actuator is installed horizontally or vertically and vibrated in the up and down directions, the actuator withstands vibration of 2.5G (at from 5 to 55HZ).

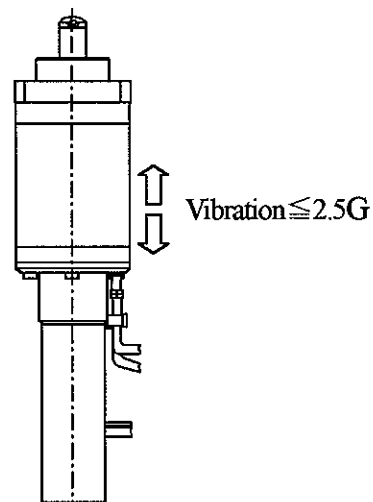
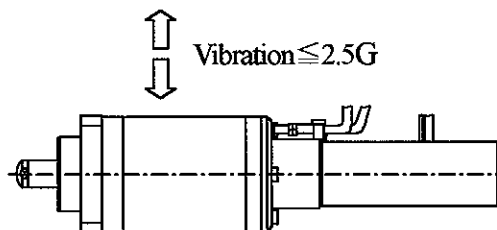

## 7.5 Life

The life of the linear actuator depends on the life of its ball screw. The equation of the life is as follows:

$$L_s = \left( \frac{1}{F_a} \right)^3 \times 2.5 \times 10^5$$

Ls: Accumulated travel life (10% probability of failure) [km]

Fa: Average axial load [kgf]

## 8. Notices at system design and on usage

The actuators are designed for highly precise positioning. Wrong usage and bad environment cause poor positioning, and shorter life and failure of the actuators.

### 8.1 Envelopment

Install and use the actuators in the environment as follows:

- Indoor
- Ambient temperature: 10 ~ 25°C, The temperature fluctuation is recommended to be within  $\pm 1^\circ\text{C}$ .
- Ambient humidity: 35 ~ 80% RH (Non-condensation)
- Vibration: Less than 2G (No vibration is recommended, fundamentally)
- No water or oil drip
- No corrosive gas, no explosive gas, no dust, no powder

### 8.2 Install direction

No limitation on install direction. However, pay attention to holding force, when the actuator is installed vertically.

### 8.3 Load direction

The load direction to the output rod should be one way load of pushing direction or pulling direction.

In order to get high positioning accuracy, pre-load of 5 kgf or more should be applied to the rod, because of no pre-load mechanism in the actuators.

- The hardness of the part to attach the actuator load should be  $H_{RC} 55\sim65$ , when the load is toward pushing direction to the actuator rod.
- When the load is toward pulling direction to the actuator, take off the screw attached at the head of the rod, and attach the load mechanism using the internal thread.

Size of internal thread: M6 P=0.75 (Fine screw thread)

Depth limit of internal thread: 10 mm

Tightening torque for internal thread: Less than 12 kgf·cm

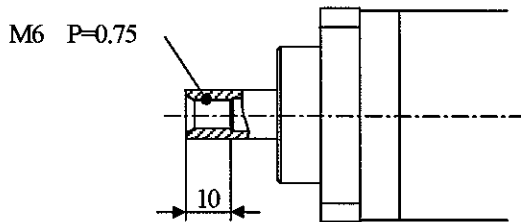

### 8.4 Notices at driving

Avoid blocking rod extrusion. It may cause worse characteristics of actuator, like positioning accuracy, and shorter life.

### 8.5 Stroke limits and rod position at shipping

Do not move actuator rod exceeding the stroke limit shown below. Otherwise, performance of the actuator may be worse, and life may be shorten.

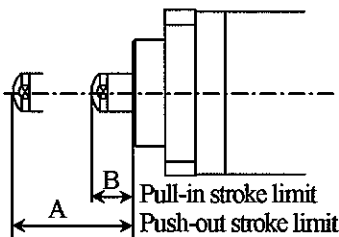

Model	A	B
LAH-46-1002-F	17	5
LAH-46-3002-F	37	5

The rod position at shipping is the center of the movable range.

## 8.6 Limit switches

The linear actuators have limit switches built-in on both stroke ends. However, no control circuit is provided to stop its motion at a stroke end. Users should make a host control system to stop the actuator by activation signal of the limit switches.

### ■ Limit switch specifications

Manufacturer:	Matsushita Denko Co. Ltd.
Model:	FU switch AV4024
Load capacity:	0.5A, 30VDC for resistive load
Lead wires:	(+): for Push-out side limit switch (-): for Pull-in side limit switch
Lead color:	Black: Common (COM) White: Normal open (NO) Red: Normal close (NC)

## 8.7 Relationship between input signal and actuator motion

- The relationship between displacement and input signal pulse is given by the following equation.

$$\text{Rod Displacement (mm)} = \frac{\text{Input Signal Pulse (pulse)}}{14400}$$

Do not move the rod beyond a motion limit.

- Rod speed is given by the following equation:

$$\text{Rod Speed (mm / sec)} = \frac{\text{Input Signal Pulse Speed (pps)}}{14400}$$

Do not exceed the rod speed more than 3.7mm / sec.

## 9. Connections

### 9.1 Motor connection and moving direction

The rod moves toward pushing direction when power supply (+) to white motor lead, and (-) to black motor lead.

### 9.2 Color of encoder leads

Brown:	Channel A
Red:	Channel B
Yellow:	Channel Z (Index)
White:	Power supply +5VDC
Black:	Ground (COM)
Shield:	Floating

**Notice: Do not measure resistance of encoder circuitry. Measuring may cause encoder failure.**

### 9.3 Treatment of encoder lead

Do not apply tensile force of more than 0.5 kg to an encoder lead and a motor lead.  
Slacken off encoder leads for their installation. Do not bend an encoder lead less than 40mm of curvature radius.

### 9.4 Motor lead extension

Use cable of 0.8mm<sup>2</sup> or thicker for extension.  
To avoid noise influence to surrounding circuitry, use shielded cable.

### 9.5 Encoder lead extension

- Twist shielded cable is recommended for extension encoder cable. When the extension cable length is shorter than 2m, shield cable is possible to use.

Total length of the extension cable should be less than 10m. The length is near to 10m, check the followings:

- ① Check the supplied voltage at the extension cable end of encoder side whether it is more than rated value.
- ② Check the signal pulse form at the extension cable end of encoder side whether the rise-form delays by the influence of stray capacitance of the long cable.

Contact us when the cable length exceeds 10m.

Do not use a single cable for motor power leads and encoder leads. Take care not to be affected by noise from signal lines for other equipment, if the lines uses same extension cable for the encoder.

Take care that an interface circuit for the encoder is not affected by noise. Followings show typical interface circuit for long extension encoder cable.

■ Direct inputting to C-MOS gate

This is useful when the extension is relatively short (a few meter) and noise circumstance is good.

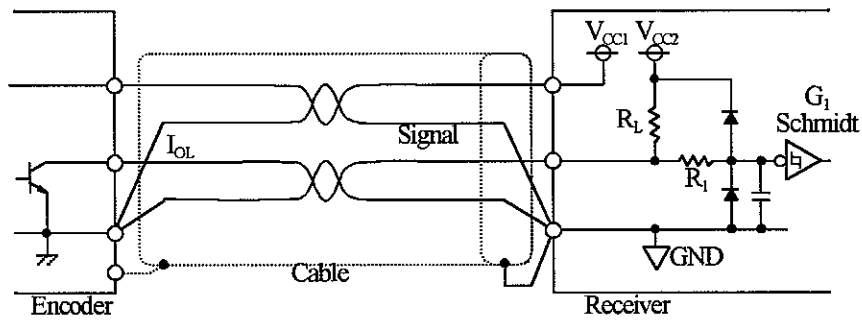

- (1) Set the pull-up resistance ( $R_L$ ) with the following equation so that  $I_{OL}$  is 5~20mA.

$$I_{OL} = \frac{V_{CC2}}{R_L} \quad (\text{A})$$

- (2) Set the filter constant ( $R_1, C_1$ ) so that the cut-off frequency ( $f_c$ ) is more than 2.8 times of the maximum signal pulse frequency.

$$f_c = \frac{1}{2\pi \times C_1 \times R_1} \quad (\text{Hz})$$

$$C_1 \leq 1000 \text{ pF}$$

- (3) Shield line should be connected to receiver ground (GND) or metal flame.  
 (4) If noise circumstance is good, usual shield cable may usable. However twist shield cable is recommended.

■ Connection through photo isolator

This is useful when the extension distance is less than 10m.

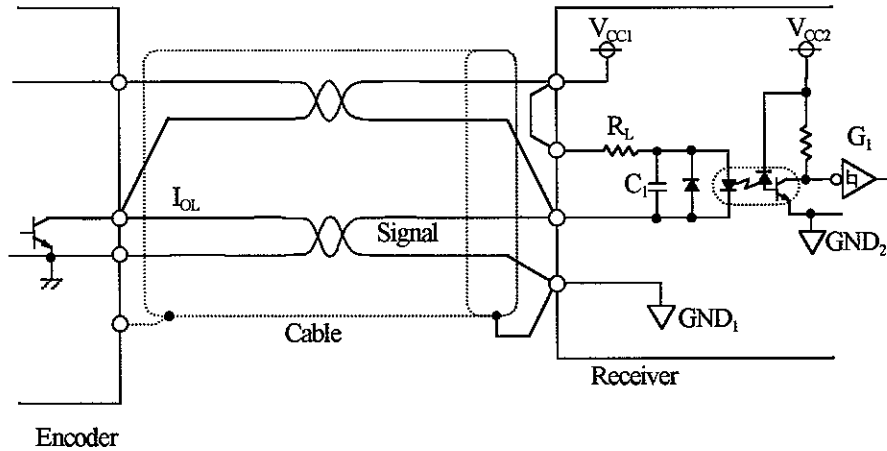

- (1) Photo isolator: TLP550 (Maximum: around 50kHz) for an example
- (2) Set the pull-up resistance (R<sub>L</sub>) with the following equation so that I<sub>OL</sub> is 10~20mA.

$$I_{OL} = \frac{V_{CC1} - V_F}{R_L} \quad (\text{A})$$

V<sub>F</sub>: Input forward voltage for photo isolator (approximately 1V to 1.6V)

- (3) Set the filter constant (R<sub>1</sub>, C<sub>1</sub>) so that the cut-off frequency (f<sub>c</sub>) is more than 2.8 times of the maximum signal pulse frequency.

$$f_c = \frac{1}{2\pi \times C_1 \times R_L} \quad (\text{Hz})$$

$$C_1 \leq 1000 \text{ pF}$$

- (4) Shield line should be connected to receiver ground (GND<sub>1</sub>) or metal frame.
- (5) If noise circumstance is good, usual shield cable may usable. However twist shield cable is recommended.

■ Influence of cable stray capacitance to signal wave form

Cable stray capacitance deforms and delays signal wave form as shown in the figure below.

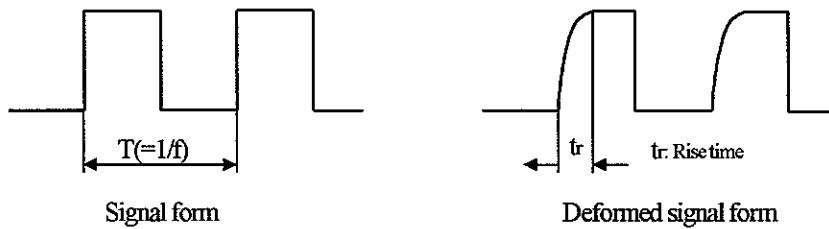

When “ $t_r$ ” is longer than “ $T/8$ ” ( $t_r \geq T/8$ ), signal transmission problem may occur. The limit length of the cable is obtained from the equation below:

$$n = \frac{1}{18.4 \times C_s \times R_L \times f} \quad (\text{m})$$

Where: n: Limit cable length (m)

$C_s$ : Stray capacitance of cable (F/m)

$R_L$ : Load resistance (or pull-up resistance) ( $\Omega$ )

f: Encoder frequency (pps)

For safety, half length of the value obtained from above equation is recommended for the limit. When the actual length for the cable is longer than the half, make small  $C_s$  and  $R_L$ , or use line driver/receiver system. (Contact us regarding the system.)

# 10. Control unit

There are two models of the control unit for the linear actuators.

## (1) Digital signal input model: HS-330-05

The model is possible to accept pulse trains to control positioning and speed of the linear actuators.

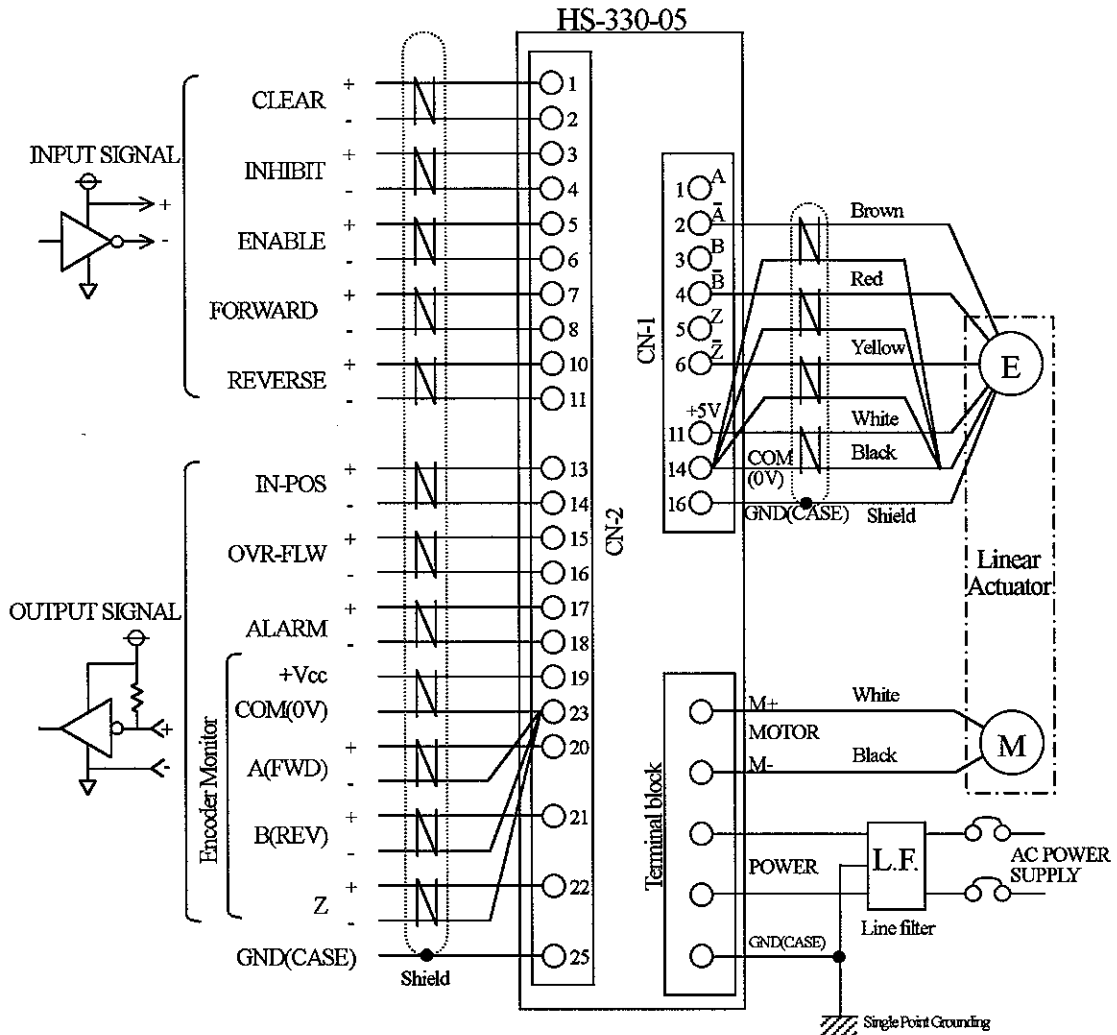

Note: GND(CASE) terminal is connected to inside of the frame.

### Notice at encoder connection:

Take care the followings at encoder connection; otherwise the miss connection causes failures of the control unit and/or the encoder on the actuator.

- Inverse connection of +5V and COM (0V)
- Miss connection of signal lead to +5V.

Request the technical document of the control unit to us.

(2) Data communication model: **HS-430-05**

The model is possible to accept GP-IB and RS-232C data communication to control positioning and speed of the linear actuators.

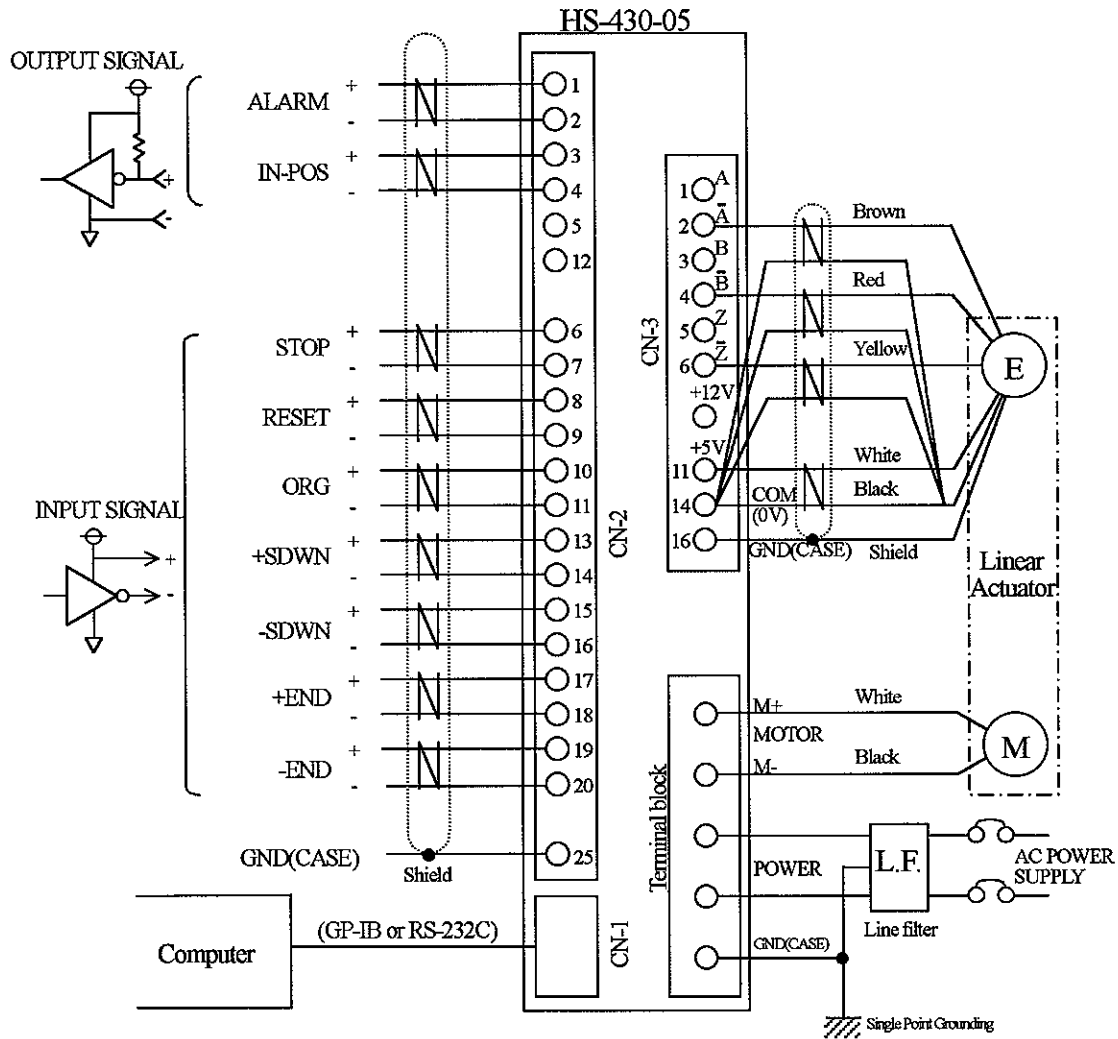

Note: GND(CASE) terminal is connected to inside of the frame.

**Notice at encoder connection:**

**Take care the followings at encoder connection; otherwise the miss connection causes failures of the control unit and/or the encoder on the actuator.**

- Inverse connection of +5V and COM (0V)
- Miss connection of signal lead to +5V.

## 11. Trial operation

Make trial operation, without load if possible, following to confirmations below:

### ■ Before trial operation

- (1) Check the actuator installation tightly.
- (2) Check the wiring for the motor, the encoder and limit switches correctly.
- (3) No obstacles interfering with the rod motion.

### ■ During trial operation

- (1) Check any abnormal vibrations.
- (2) Check any abnormal noises.
- (3) Is motor temperature rise normal?
- (4) Is rod movement smooth?

## 12. Storing

### 12.1 Storing place

- No dust, no powder, no water or oil drop
- No corrosive gas, no liquid
- Ambient temperature: -20°C to +50°C
- Ambient humidity: 10%RH to 80%RH (No water condensation)

### 12.2 Anti-corrosion

- Move the output rod several times in the range of full-stroke supplying power in every three months, because of anti-corrosion for sliding portions and motor brushes.
- Seal up the actuator with a desiccant in a plastic bag

### 12.3 Storing posture

Store the actuator with horizontal portion or vertical portion of the rod being upside.

## **GUARANTEE**

Unless as specified otherwise in the order or stated in the provisions of the contract, the guarantee shall be provided for a duration of one (1) year after the delivery of the product.

In case of defects inherent in the product resulting from design or craftsmanship within the duration set forth, the defective component will be subject to repair or replacement free of charge.

Note: Product specifications are subject to change without notice for improvement purposes.