

D C S e r v o S y s t e m s

RH Mini Series
RHS and RFS Series

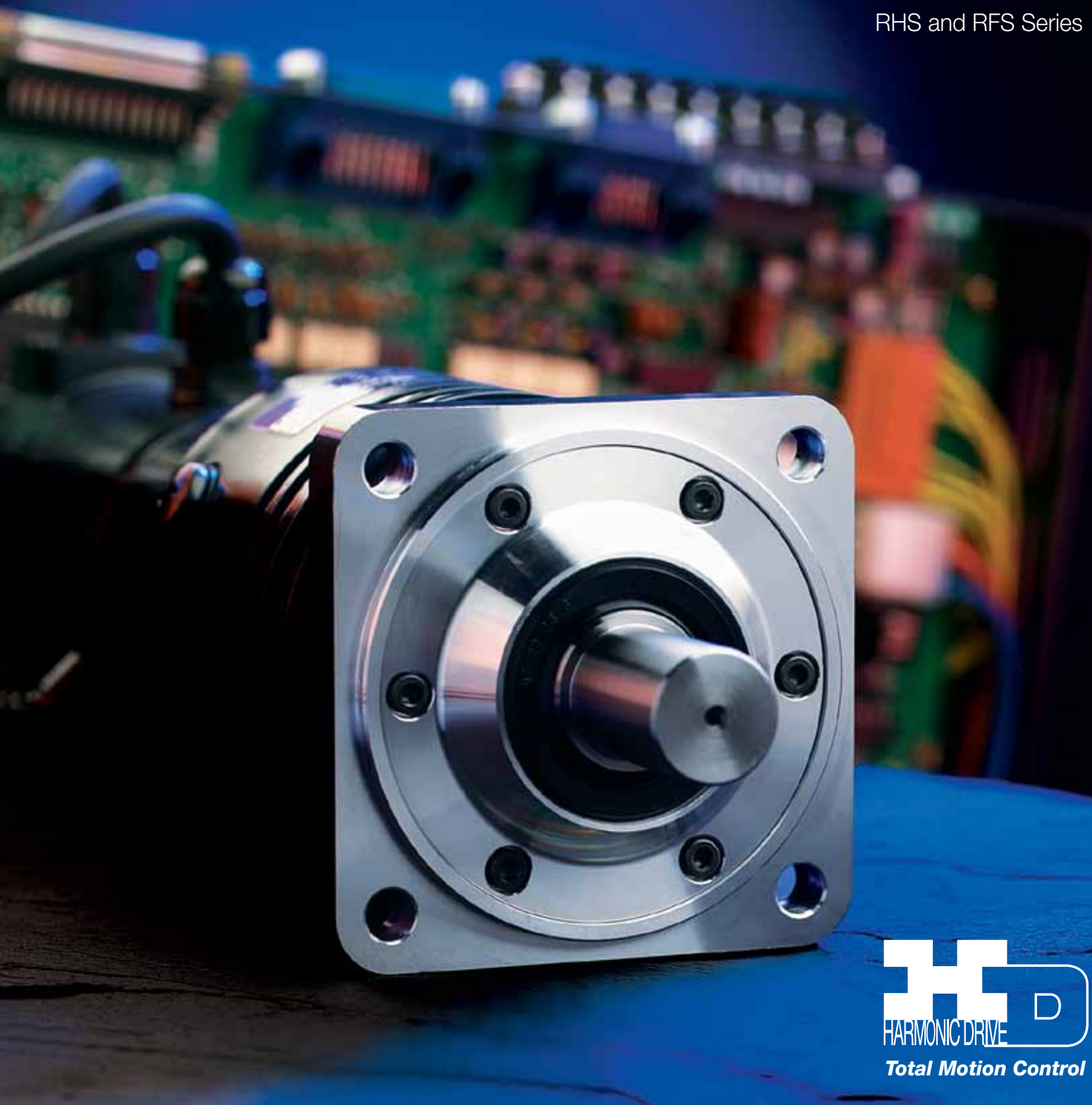

Harmonic Drive™ acuator

P r e c i s i o n G e a r i n g & M o t i o n C o n t r o l

Precision Gearing & Motion Control

DC SERVO ACTUATORS

FEATURES: • ZERO BACKLASH • HIGH POSITIONAL ACCURACY • HIGH STIFFNESS



The RH mini series actuators are used in highly demanding industrial servo systems and provide precision motion control and high torque capacity in very compact packages. RHS and RFS series DC servo actuators feature the patented “S” series Harmonic Drive™ precision gearbox for high torque, high torsional stiffness, and high performance. These actuators are powerful yet compact and are specially designed for “S” series gearing. The result is a superior DC servo system with higher power density which is used in highly demanding industrial robot and automation applications.

Select the optimum DC servo actuator

The RH, RHS, and RFS actuators, combining precision Harmonic Drive™ gear and DC servo motors offer unique features unsurpassed by conventionally geared drives. Used in highly demanding industrial servo systems, they provide precision motion control and high torque capacity in very compact packages. The tach-generator and/or encoder are directly mounted onto the motor shaft. Since the gear has zero backlash, high servo gains may be used, providing a very stiff, yet stable servo system.

The Harmonic Drive™ gear is lubricated with a specially developed grease to ensure minimum maintenance requirements and long service life. The motor brush holders have seals to prevent dust transfer.

Selection Procedure	4
RH Mini Series DC Servo Actuators	6
Technical Data	6
Performance Curves	7
Duty Cycle Characteristics	8
Loading Curves	8
Motor	9
Tach-Generator	9
Encoder	10
Weights	11
Output Shaft Tolerances	11
Dimensions	12
RHS/RFS Series DC Servo Actuators	16
Technical Data	18
Performance Curves	21
Duty Cycle Characteristics	21
Loading Curves	23
Motor	23
Tach-Generator	23
Encoder	23
Weights	25
Output Shaft and Flange Tolerances	25
Dimensions	26
Ordering Code	40

Selection Procedure

Requirements for Preliminary Selection

- Load Torque T_L [Nm] < Rated Torque T_N [Nm]
- Load Speed n_L [rpm] < Rated Output Speed n_N [rpm]
- Load Inertia J_L [kgm²] < 3 J_A (Actuator Inertia) acceptable
- Load Inertia J_L [kgm²] < J_A (Actuator Inertia) for best possible dynamic response

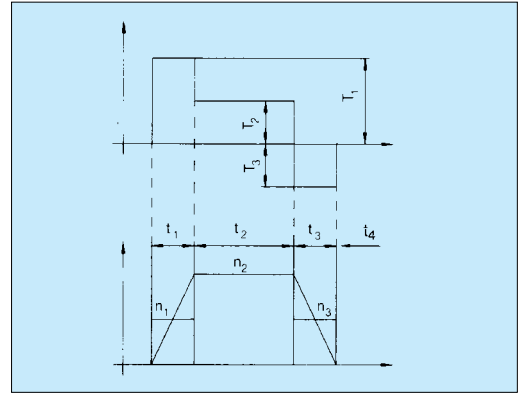

Determination of the duty cycle

Preliminary selection of the actuator

Determination of the acceleration torque T_1 [Nm]

$$T_1 = T_L + 2\pi \cdot \frac{(J_A + J_L) \cdot n_L}{t_1}$$

[Equation 1]

Acceleration Torque T_1 < Maximum Output Torque T_m
(Values for T_m see page 8, 18, and 19)

No

Select another actuator which meets this requirement

Determination of the average torque T_A [Nm]

$$T_A = \sqrt{\frac{T_1^2 \cdot t_1 + T_2^2 \cdot t_2 + T_3^2 \cdot t_3}{t_1 + t_2 + t_3 + t_4}}$$

with: T_1 = Acceleration Torque
 T_2 = T_L = Load Torque
 T_3 = $T_2 - (T_1 - T_2)$ Braking Torque
 (if $t_1 = t_3$)

[Equation 2]

Average Torque T_A < Rated Torque T_N of the actuator
(Values for T_N see page 8, 18 and 19)

No

Select another actuator which meets this requirement

Selected actuator meets all requirements

Select the required encoder resolution

Position Control required

Speed Control required

Encoder Resolution Where: n = Encoder Resolution
 R = Gear reduction ratio
 θ_A = Desired position accuracy at the output [arc-min]
 γ = Encoder multiplier

$$n \geq (5 \sim 10) \cdot \frac{60 \cdot 360}{\theta_A \cdot R \cdot \gamma}$$

[Equation 3]

Encoder Resolution Where: n_{min} = Minimum operating output speed [rpm]
 f_s = Cut-off frequency [Hz]
 For HS Series Control Units the cut-off frequency f_s can be assumed to be 100 Hz.

$$n \geq 3 \cdot \frac{60 \cdot f_s}{n_{min} \cdot R \cdot \gamma}$$

[Equation 4]

Selection of Encoder Output Type

The most suitable encoder output type can be selected according to the following basic specifications:

- ◆ AL - Line Driver (+5V version)
This type can transmit the encoder signal up to 10m and requires a 5V DC power supply
- ◆ BL - Line Driver (+12V version)
This type can transmit the encoder signal up to 100m and requires a 12V DC power supply
- ◆ DO - Open Collector (+ 4.75V to 12.6V); AO - Open Collector (+5V)
These types can transmit the encoder signal up to 10m. They should not be used in environments suffering from high levels of electrical noise.

RH Mini Series DC Servo Actuators

Technical Data

Rating:	Continuous
Excitation device:	RE Permanent magnet
Insulation:	Class B
Insulation voltage:	AC 500V, one minute
Insulation resistance:	100MΩ or more (DC 500V Megger)

Vibration:	2.5 g (5 . . . 400 Hz)
Shock:	< 30 g (11 ms)
Construction:	Totally enclosed
Lubrication:	Grease (SK-2)
Ambient temperature:	0 ~ 40°C
Ambient humidity:	20 ~ 80% (non condensing)

Item	Actuator	RH-5A		RH-8D		RH-11D		RH-14D	
		5502	6006	3006	6001	3001	6002	3002	
Rated Output Power ¹⁾	W	1.7	8.6	6.2	13.6	12.3	20.3	18.5	
Rated Voltage ¹⁾	V	12	24	24	24	24	24	24	
Rated Current ¹⁾	A	0.5	1.0	0.8	1.3	1.3	1.8	1.8	
Rated Output Torque ¹⁾ T _N	in-lb	2.6	12	17	19	34	28	52	
	Nm	0.29	1.4	2.0	2.2	3.9	3.2	5.9	
Rated Output Speed ¹⁾ n _N	rpm	55	60	30	60	30	60	30	
Max. Continuous Stall Torque ^{1) 2)}	in-lb	3.5	13	20	22	39	48	69	
	Nm	0.39	1.5	2.3	2.5	4.4	5.4	7.8	
Peak Current ^{1) 2)}	A	0.78	1.6	1.1	2.4	2.1	5.4	4.1	
Maximum Output Torque ^{1) 2)} T _m	in-lb	5.2	24	31	43	69	122	174	
	Nm	0.59	2.7	3.5	4.9	7.8	14	20	
Maximum Output Speed ¹⁾	rpm	110	100	50	100	50	100	50	
Torque Constant	in-lb/A	10	19	37	22	43	26	51	
	Nm/A	1.11	2.10	4.20	2.46	4.91	2.92	5.76	
Voltage Constant (B.E.M.F.)	V/rpm	0.12	0.22	0.44	0.26	0.50	0.30	0.60	
Inertia at Output Shaft ³⁾	in-lb · sec ²	0.014	0.033	0.13	0.095	0.38	0.18	0.72	
	kgm ² · x10 ³	1.6	3.7	15.0	11.0	43.0	21.6	81.6	
Mechanical Time Constant	msec	13.3	8.5	8.5	8.5	8.5	7.0	7.0	
Torque-Speed Gradient	in-lb/rpm	0.14	0.42	1.6	1.2	4.6	2.9	11	
	Nm/rpm	1.6 · 10 ⁻²	4.7 · 10 ⁻²	1.8 · 10 ⁻¹	1.4 · 10 ⁻¹	5.2 · 10 ⁻¹	3.2 · 10 ⁻¹	1.2	
Viscous Damping Constant	in-lb/rpm	0.20	0.086	0.27	0.16	0.62	0.31	1.3	
	Nm/rpm	2.3 · 10 ⁻³	9.7 · 10 ⁻³	3.1 · 10 ⁻²	1.8 · 10 ⁻²	1.7 · 10 ⁻²	3.5 · 10 ⁻²	1.5 · 10 ⁻¹	
Rated Power Rate ¹⁾	kW/sec	0.055	0.51	0.26	0.43	0.36	0.51	0.42	
Thermal Time Constant ¹⁾	min	5.2	9	9	10	10	11	11	
Thermal Resistance ¹⁾	°C/W	11.4	4.2	4.2	3.3	3.3	2.8	2.8	
Gear Ratio	1:R	80	50	100	50	100	50	100	
Maximum Radial Load ⁶⁾	lb	13	44	44	55	55	88	88	
	N	59	196	196	245	245	392	392	
Maximum Axial Load	lb	7	22	22	44	44	88	88	
	N	29	98	98	196	196	392	392	
Motor Rated Output ^{1) 5)}	W	(2.6)	(10)	(10)	(20)	(20)	(30)	(30)	
Motor Rated Speed ¹⁾	rpm	4500	3000	3000	3000	3000	3000	3000	
Armature Resistance	Ω	8.6	10	10	4.7	4.7	2.7	2.7	
Armature Inductance	mH	2.7	2.2	2.2	1.6	1.6	1.1	1.1	
Electrical Time Constant	ms	0.31	0.22	0.22	0.34	0.34	0.41	0.41	
Starting Current	A	0.13	0.24	0.24	0.31	0.31	0.43	0.43	
No-Load Running Current ⁴⁾	A	0.24	0.38	0.36	0.61	0.55	0.89	0.91	
Actuator Accuracy	arc-min	4.5	2.5		2.0		2.0		
Actuator Repeatability	arc-sec	±90	±60		±60		±60		

Table 2

Additional information

* Actuator specifications show output characteristics, including gear efficiency.

* All specifications are applicable for actuators mounted on aluminum heat sink of the following sizes:

RH-5: 100 x 100 x 3 mm,

RH-8, 11, 14: 150 x 150 x 6 mm.

Please Note:

¹⁾ The values are for saturated actuator temperature. Other values (not marked with ¹⁾) are for actuator temperature of 20°C.

²⁾ The values given represent an upper limit and actual load values should be lower.

³⁾ The tabulated value is the moment of inertia reflected to the output shaft resulting from the sum of the motor inertia and the gear inertia.

⁴⁾ Values are for rated output speed.

⁵⁾ Values are for reference only.

⁶⁾ Cantilevered load applied at the midpoint of the shaft extension.

Performance Curves

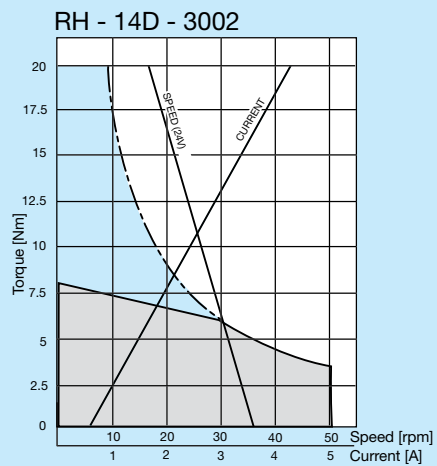
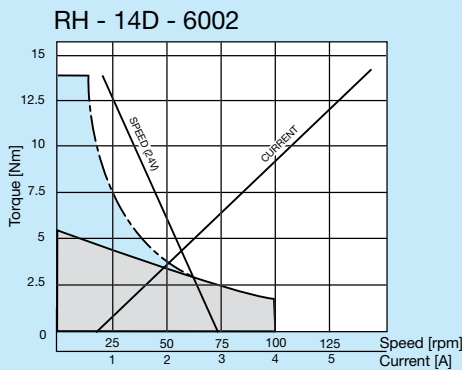
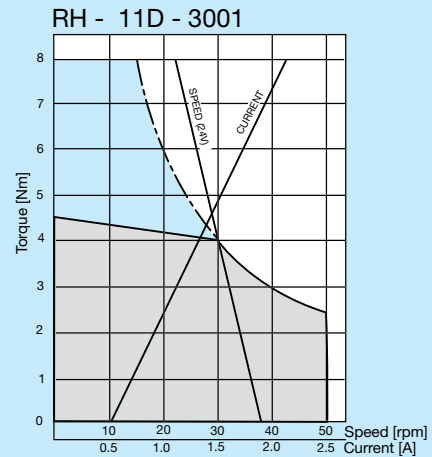
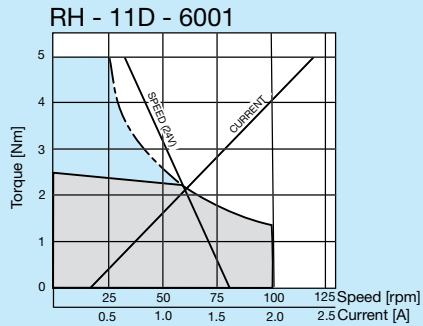
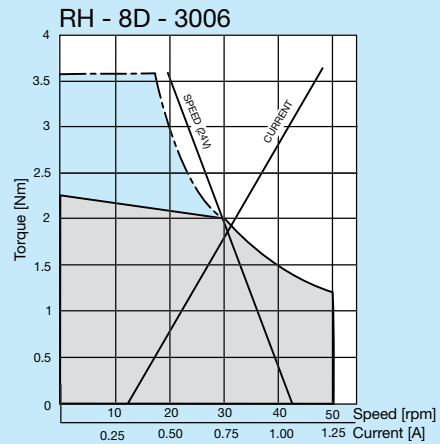
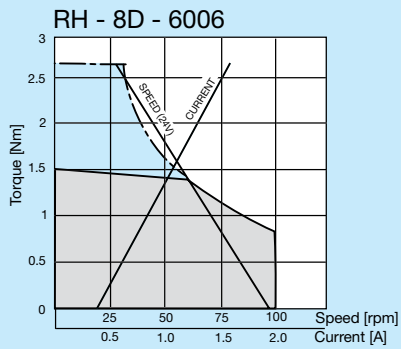
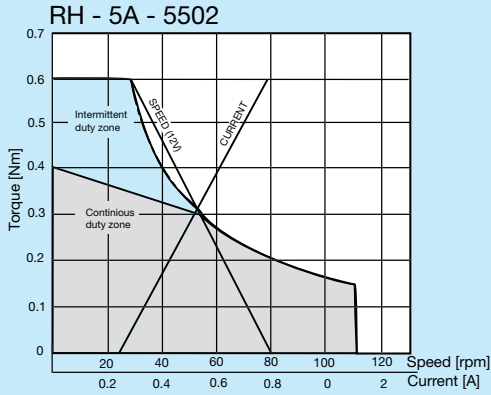

Duty Cycle Characteristics

When an actuator is repeatedly operated above the rated torque and speed for periods of 0.1 minute or more, the minimum idle time required to prevent damage from overheating can be calculated from the graphs on this page once the load factor and the duty factor have been established.

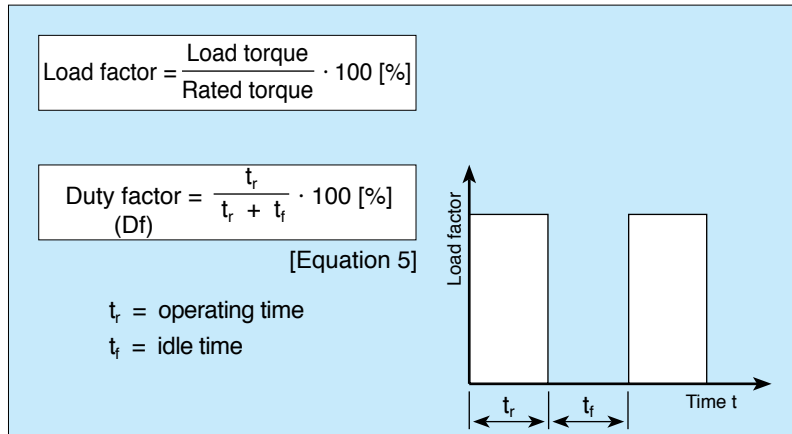

Calculation example: RH-14D-6002 actuator

For a given load factor of 150% and duty factor of 30% a permissible operating time $t_r = 4$ minutes can be read from the curve. For a duty factor of 30% this means that an idle time $t_i = 9.3$ minutes is required between operations.

$$\frac{t_r}{t_r + t_i} \cdot 100 \% = 30\%$$

$$t_i = \frac{t_r}{Df} - t_r = \frac{4}{.3} - 4 = 9.3 \text{ minutes}$$

Loading Curves

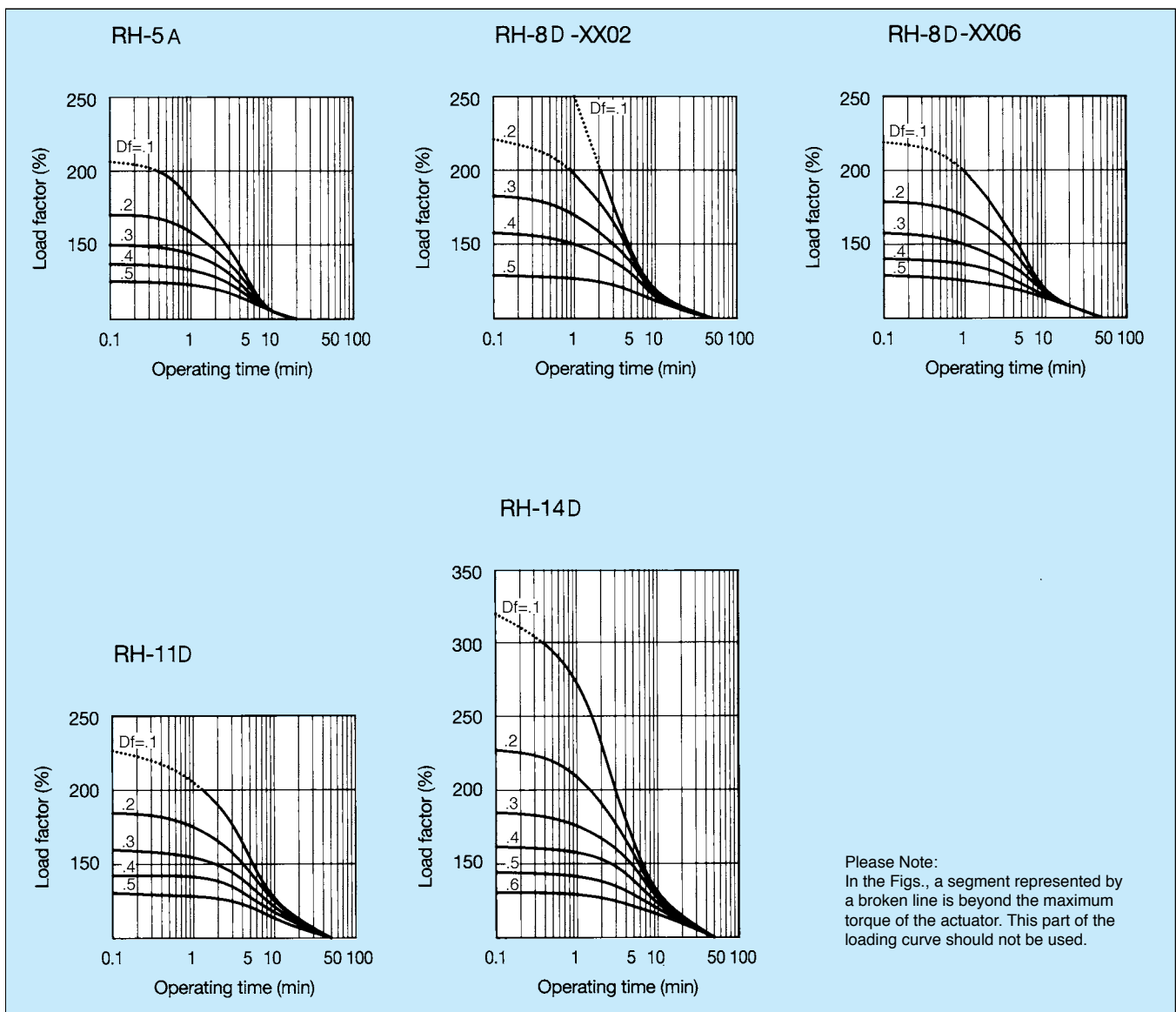

Motor

Polarity

The output shaft rotation is clockwise (when viewed from the output shaft of the actuator), when the voltage applied to the white motor lead is positive with respect to the black lead.

Motor Lead Wires

Table 3

Actuator	Wire	
	length (m)	c. s. area (mm ²)
RH-5A	0.3	0.08
RH-8D	0.6	0.4
RH-11D	0.6	0.4
RH-14D	0.6	0.4

Tach-Generator

For the Mini Series RH-8D, RH-11D and RH-14D, a DC tach- generator is available as an option. The specification of the tach- generator is given in the table below.

Table 4

Output voltage	3 V \pm 10% / 1000 rpm
Ripple (RMS) ¹⁾	1% (200~5000 rpm)
Ripple (peak to peak) ¹⁾	3% (200~5000 rpm)
Linearity ¹⁾	1% (200~5000 rpm)
Direction deviation	1% (200~5000 rpm)
Temperature coefficient	< 0.02% / °C
Moment of Inertia ²⁾	1.2 x 10 ⁻⁶
Armature resistance	45 Ω \pm 10% (at 20 °C)
Armature inductance	7 mH \pm 20%
Maximum rotation speed	5000 rpm
Friction torque	< 4 x 10 ⁻³ Nm
Minimum load resistance	10 k Ω
Insulation resistance	100 M Ω (DC 500 V Megger)
Breakdown voltage	AC 500 V / 1 minute
Weight	0.08 kg

Please note:

- ¹⁾ This value refers to the tach-generator only.
- ²⁾ This value is referred to the motor shaft. For the moment of inertia referred to the actuator output shaft multiply this value by the square of the reduction ratio.

Tach-Generator Lead Wires

heat resistant vinyl wire (0.4 mm²)

Table 5

Actuator	Wire	
	length (m)	c. s. area (mm ²)
RH-8D	0.6	0.4
RH-11D	0.6	0.4
RH-14D	0.6	0.4

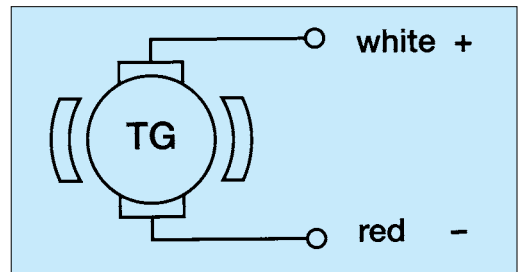
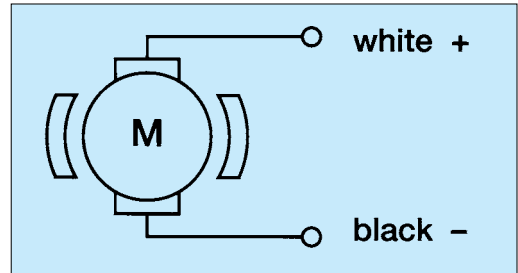

Polarity

When the rotation is clockwise viewed from the output shaft, white is positive, and red is negative.

Testing Circuit for Output Voltage, Linearity and Ripple:

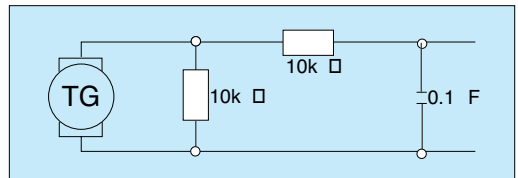

Encoder

Table 6

Type		RH-5A			RH-8D, RH-11D, RH-14D							
Output Circuit		Open Collector	Line Driver		Open Collector				Line Driver			
		AO	AL		DO				AL	BL		
Power Supply ²⁾	VDC	+ 5 ± 5%			+4.75 ~+12.6				+ 5 ± 5%	+7 ~+12.6		
	mA	60 max.	170 max.		60 max.				170 max.			
Output Voltage V_{OL}, V_{OH}	V	0.5 max., -		0.5max., 2.5 in.	0.5 max., -				0.5 max. , 2.5 min.			
Max. Response Frequency	kHz	100			125				125			
Resolution ¹⁾	P/rev	200	360	500	200	360	500	1000	200	360	500	1000
Output Signal		A, B, Z		A, \bar{A} , B, \bar{B} , Z, \bar{Z}	A, B, Z				A, \bar{A} , B, \bar{B} , Z, \bar{Z}			
Max. Voltage V_{CC}	VDC	36		-	36				-			
Max. Current I_{OL}	A	20 max.			20 max.				20 max.			
Moment of Inertia ³⁾	kgm ²	2×10^{-9}			3×10^{-8}				3×10^{-8}			
Lead Wire	mm	Ø 3 x 300L Ø 0.08/7 Strand			Ø 4 x 600L Ø 0.12/7 Strand				Ø 4 x 600L Ø 0.12/7 Strand			

Please note:

¹⁾ Resolution of encoder only. Resolution at the output of the actuator is equal to the encoder resolution multiplied by the reduction ratio.

²⁾ 12 V DC is recommended in case of cable length longer than 10 m (5 V for AL-type, 12 V for BL-type).

³⁾ Moment of inertia referred to the motor shaft.

RH-5A Open Collector AO

● Output Circuit

$V_{CC} = +5V \sim 12V$
 $I_{OL} = 20mA \text{ Max.}$

$T = \text{Average cycle}$
 $a, b, c, d = 0.25T \pm 0.1$
 $e = 0.5T \pm 0.1$
 $\Delta T \leq 0.1T$

CW FACING MOUNTING END

RH-8D /11D /14D Line Driver

● Output Circuit

Shield or common ground
 $R_T : 150\Omega$ (terminator resistance)
iC: Am26LS32 (or equivalent)

$V_{CC} = +5V \sim 12V$
 $I_{OL} = 20mA \text{ Max.}$

● Output Wave Form

$T = \text{Average cycle}$
 $a, b, c, d = 0.25T \pm 0.1T$
 $e = 0.5T \pm 0.1T$
 $\Delta T \leq 0.1T$
Z Signal is synchronized with A Signal

CW facing mounting end

RH-8D /11D /14D Open Collector DO

● Output Circuit

$V_{CC} = +5V \sim 12V$
 $I_{OL} = 20mA \text{ Max.}$

● Output Wave Form

$T = \text{Average cycle}$
 $a, b, c, d = 0.25T \pm 0.1T$
 $e = 0.5T \pm 0.1T$
 $\Delta T \leq 0.1T$
Z Signal is synchronized with A Signal

CW facing mounting end

Encoder Wiring

Table 7

RH-5A/8D/11D/14D ¹⁾	Line Driver AL/BL	Open Collector AO	Open Collector DO
Brown	A Signal	A Signal Output	A Signal Output
Blue	\bar{A} Signal	NA	A Signal Common
Red	B Signal	B Signal Output	B Signal Output
Green	\bar{B} Signal	NA	A Signal Common
Yellow	Z Signal	Z Signal Output	Z Signal Output
Orange	\bar{Z} Signal	NA	A Signal Common
White	Power Supply	Power Supply	Power Supply
Black	Common	Common	Common
Shield	Floating	Floating	Floating

¹⁾ Please Note: If the option tach-generator is used in combination with an encoder the wiring of the encoder may vary from the above table.

Encoder Resolutions

Table 8

Actuator	Resolution						
	100	200	300	360	500	720	1000
RH-5A	—	○	—	●	○	—	—
RH-8D/11D/14D	—	○	—	○	○	—	●

● = Standard ○ = Available (special option) — = not available

Since the encoder is connected to the motor side, the resolution is calculated at the actuator output shaft as shown below. For example, when the reduction ratio is 1:100, and the resolution of an encoder is 1000, the resolution at the output shaft becomes $1000 \times 100 = 100000$.

Tach and Encoder Configurations

Table 9

Actuator	Tach	AO	DO	AL	BL
RH-5A	no	●	—	●	—
RH-8D/11D/14D	no	—	●	●	●
RH-8D/11D/14D	yes	—	○	○	—

● = Standard — = not available ○ = Option

Encoder Lead Wires

Table 10

Actuator	Tach	Open Collector AO		Open Collector DO		Line Driver AL		Line Driver BL	
		Length (mm)	Diameter	Length (mm)	Diameter	Length (mm)	Diameter	Length (mm)	Diameter
RH-5A	no	300	4	—	—	600	4	—	—
RH-8D/11D/14D	no	—	—	600	4	600	4	600	4
RH-8D/11D/14D	yes	600	4	—	—	600	5	—	—

Weights

Table 11

Actuator	Gearbox and Motor	Including Tach	Including Encoder	Including Tach and Encoder
RH-5A	0.07	—	0.09	—
RH-8D	0.27	0.35	0.31	0.39
RH-11D	0.47	0.55	0.51	0.59
RH-14D	0.74	0.82	0.78	0.86

Output Shaft Tolerances

The following table provides the geometric tolerances for the output shaft.

mm

Table 12

Actuator	Concentricity \odot a	Perpendicularity \perp b	Run-out \blacktriangleright c
RH-5A	0.04	0.04	0.02
RH-8D	0.04	0.04	0.02
RH-11D	0.04	0.04	0.02
RH-14D	0.04	0.04	0.02

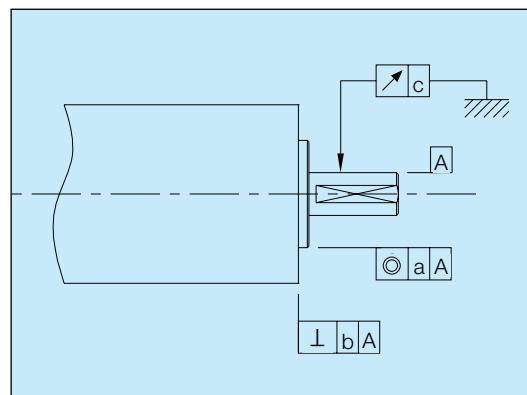

Dimensions

mm

RH-5A-XX02 Actuator Only

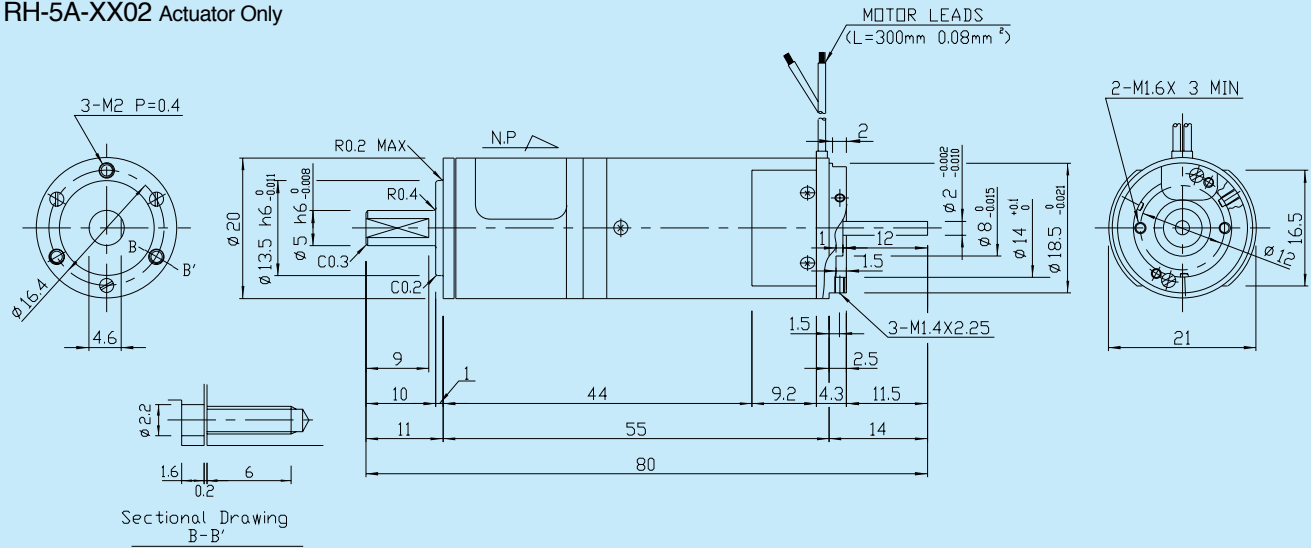

RH-5A-XX02-E036AO With 360 PPR Encoder

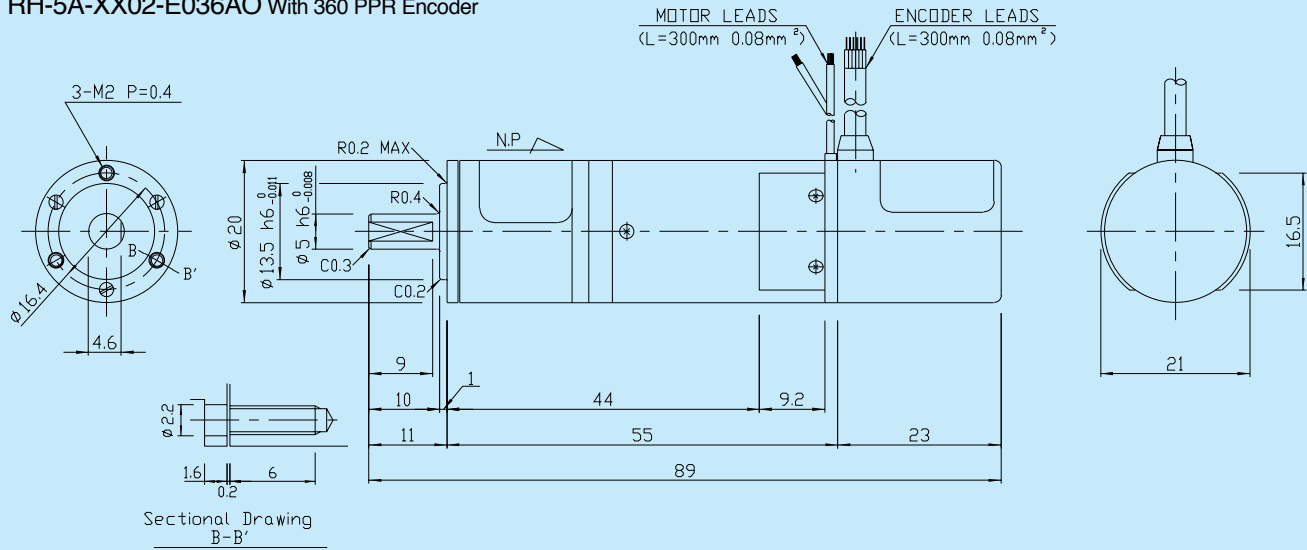

RH-5A-XX02-E050AO With 500 PPR Encoder

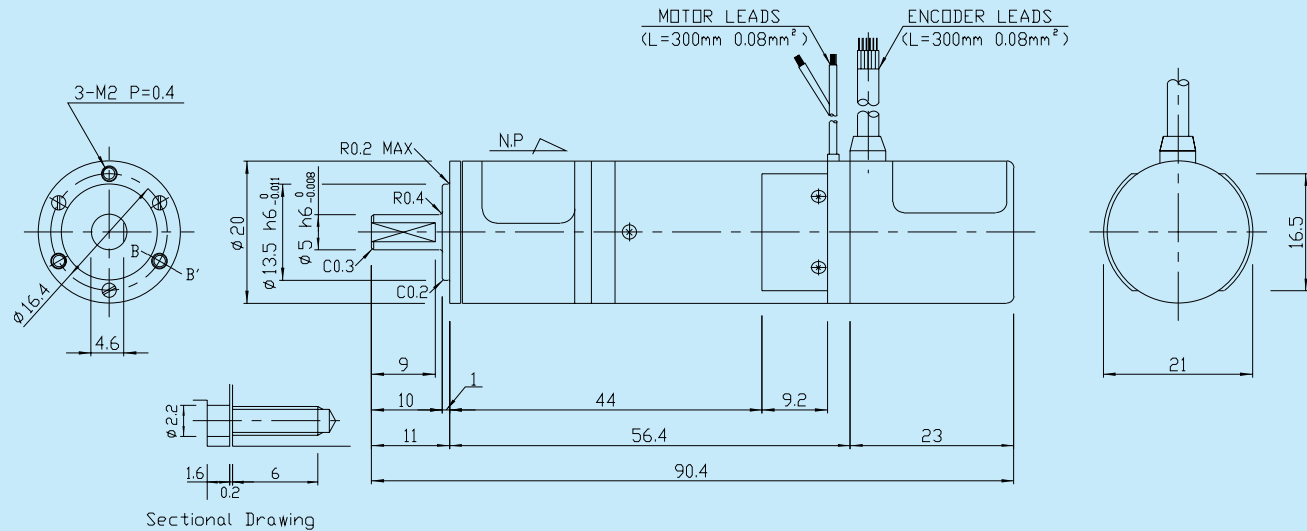

Please Note: Valid for encoder types AO, DO and AL. Please add 9 mm for the BL-type encoder.

RH-8D-XX06 Actuator Only

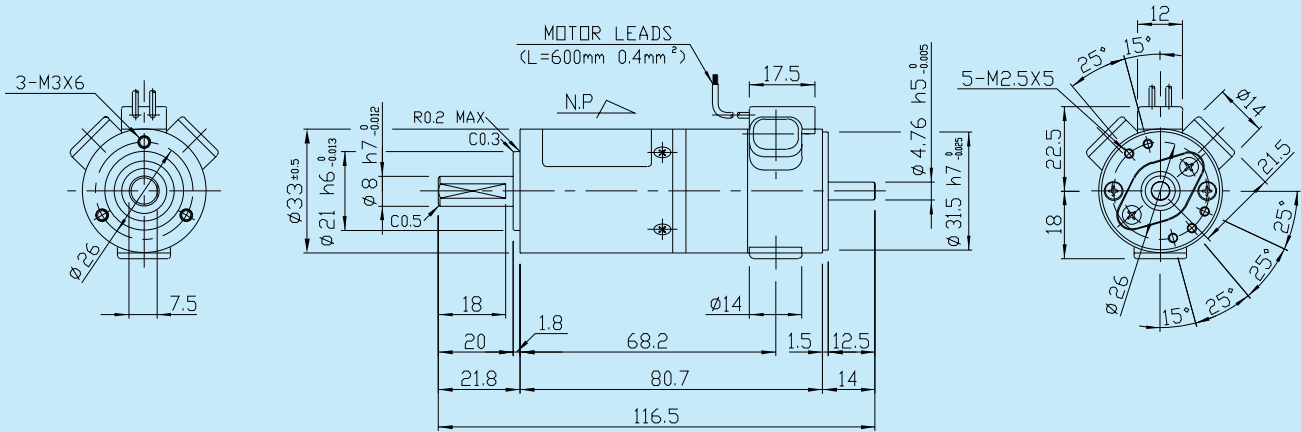

RH-8D-XX06-T With Tach-Generator

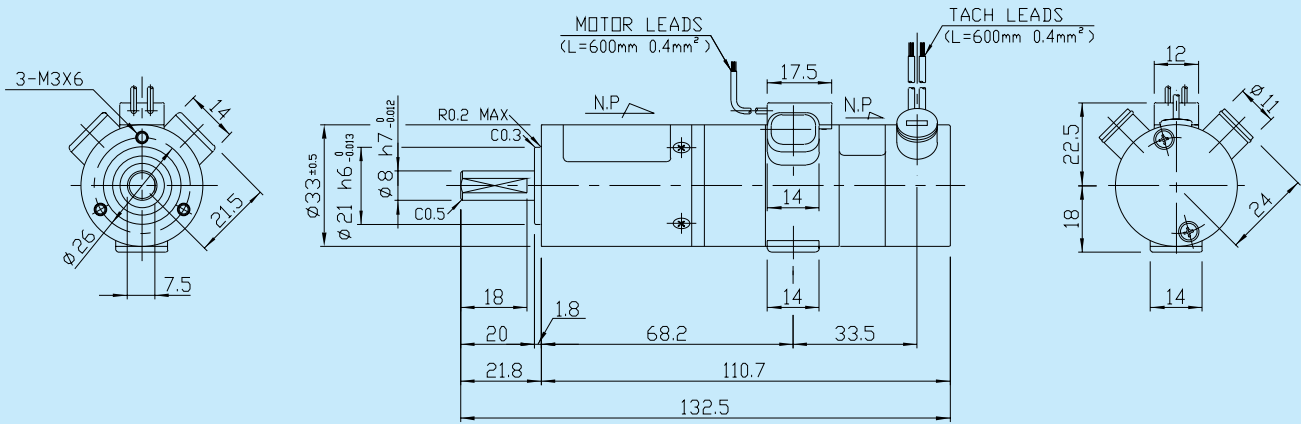

RH-8D-XX06-E With Encoder

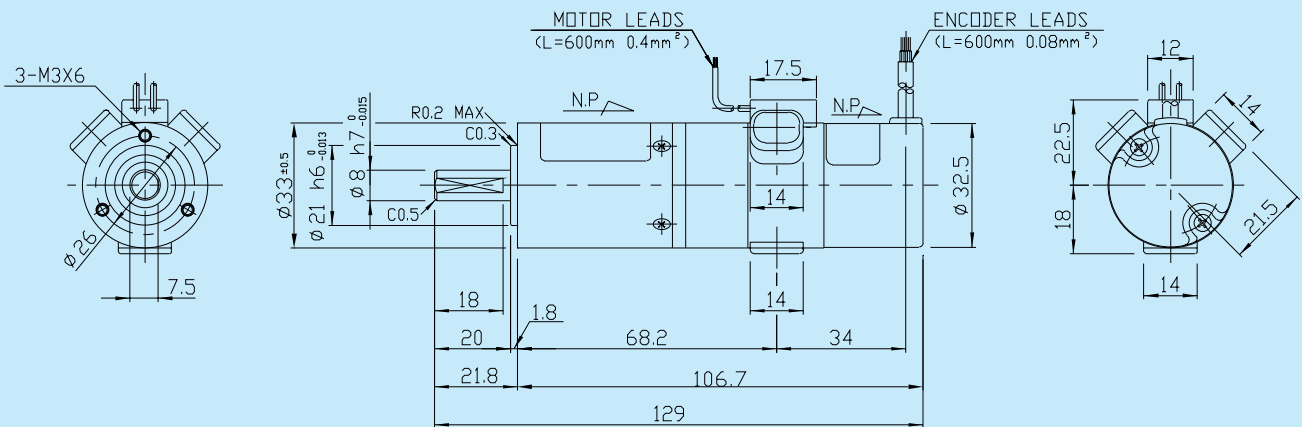

Please Note: Valid for encoder types AO, DO and AL. Please add 9 mm for the BL-type encoder.

RH-11D-XX01 Actuator Only

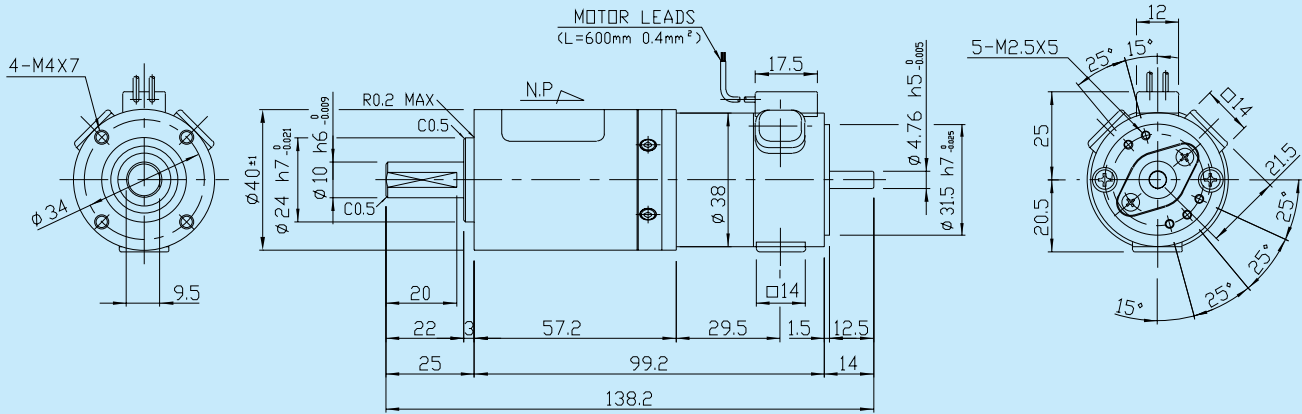

RH-11D-XX01-T With Tach-Generator

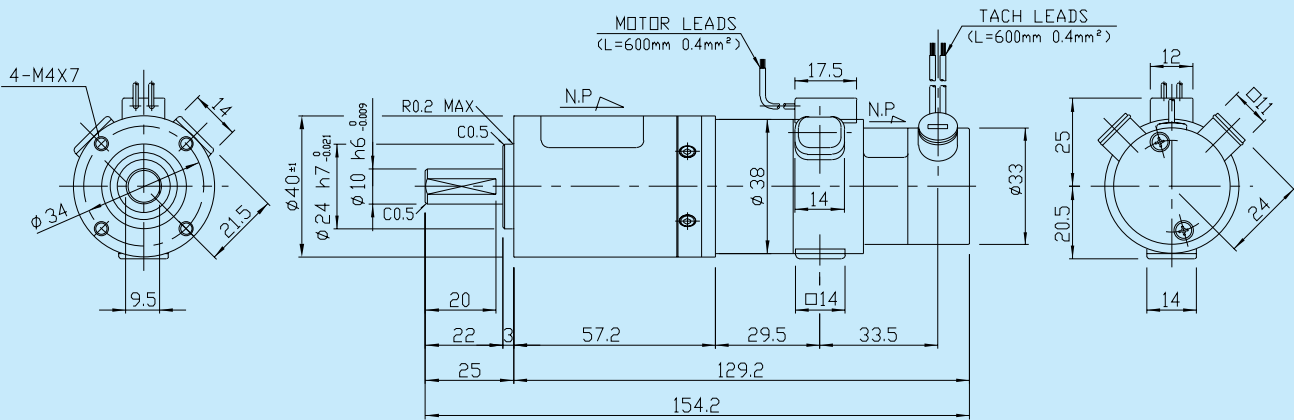

RH-11D-XX01-E With Encoder

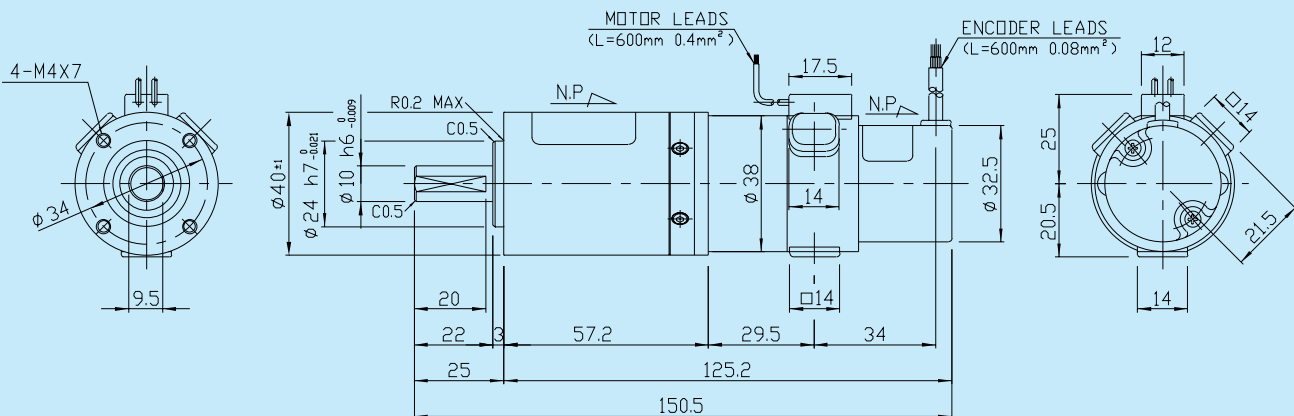

RHS Series DC Servo Actuators

Technical Data

Table 13

Item	Actuator	RHS-14		RHS-17	
		6003	3003	6006	3006
Rated Output Power ¹⁾⁴⁾	W	34	25	62	
Rated Voltage ¹⁾	V	75		75	
Rated Current ¹⁾	A	1.0	0.9	1.7	
Rated Output Torque ¹⁾ T _N	in-lb	48	69	87	174
	Nm	5.4	7.8	9.8	20
Rated Output Speed ¹⁾ n _N	rpm	60	30	60	30
Max. Continuous Stall Torque ¹⁾²⁾⁴⁾	in-lb	54	78	100	195
	Nm	6.1	8.8	11	22
Peak Current ¹⁾²⁾	A	2.4	2.0	4.3	3.5
Maximum Output Torque ¹⁾²⁾ T _m	in-lb	155	250	300	475
	Nm	18	28	34	54
Maximum Output Speed ¹⁾	rpm	100	50	80	40
Torque Constant	in-lb/A	80	160	85	170
	Nm/A	8.9	18	9.6	19
Voltage Constant (B.E.M.F.)	V/rpm	0.9	1.8	1.0	2.0
Inertia at Output Shaft	lb-in-sec ²	0.41	1.61	0.79	3.15
	kgm ²	0.45	1.8	0.089	0.36
Mechanical Time Constant	msec	6.7		4.7	
Torque-Speed Gradient	in-lb/rpm	6.2	25	18	72
	Nm/rpm	0.71	2.8	2.1	8.1
Viscous Damping Constant	in-lb/rpm	0.20	1.2	0.48	2.7
	Nm/rpm	2.3·10 ⁻²	1.4·10 ⁻¹	5.4·10 ⁻²	3.1·10 ⁻¹
Rated Power Rate ¹⁾	kW/sec	0.6	0.3	1.1	
Thermal Time Constant ¹⁾	min	14		16	
Thermal Resistance ¹⁾	°C/W	1.7		1.2	
Gear Ratio	1:R	1:50	1:100	1:50	1:100
Maximum Radial Load ³⁾	lb	88		176	
	N	392		784	
Maximum Axial Load	lb	88		176	
	N	392		784	
Motor Rated Output ¹⁾	(W)	(50)		(100)	
Motor Rated Speed ¹⁾	(rpm)	(3000)		(3000)	
Armature Resistance	Ohm	11.6		4.8	
Armature Inductance	mH	4.5		2.3	
Electrical Time Constant	msec	0.4		0.5	
Starting Current	A	0.25	0.18	0.36	0.23
No-Load Running Current ⁵⁾	A	0.4		0.7	
Actuator Accuracy	arc-min	1.5		1.5	
Actuator Repeatability	arc-sec	± 5		± 5	

Additional information

* Actuator specifications show output characteristics including gear efficiency.

* All specifications are applicable for actuators mounted on aluminum heat sink of the following sizes:

RHS/RFS-14,17, 20:
250 x 250 x 12 mm,
RHS/RFS-25 and RHS/
RFS-32:
300 x 300 x 15 mm.

Rating:	Continuous
Exciting method:	Permanent magnet
Motor Insulation:	Class F
Insulation voltage:	AC 1000V, one minute
Insulation resistance:	100MΩ (DC500V Megger)

Construction:	Totally enclosed
Ambient temperature:	-10 ~ +40°C
Storage temperature:	-20 ~ +60°C
Ambient humidity:	20 ~ 80% (non-condensing)

Vibration:	2.5g (5 ~ 400Hz)
Shock:	30g (11 ms)
Output:	Shaft (RHS series) Flange (RFS Series)
Lubrication:	Grease SK-1A (Sizes 20-32) Grease SK-2 (Sizes 14 & 17)

RHS/RFS Series DC Servo Actuators

Table 14

Item	Actuator	RHS-20, RFS-20				RHS-25, RFS-25				RHS-32, RFS-32			
		6007	3007	6012	3012	6012	3012	6018	3018	6018	3018	6030	3030
Rated Output Power ^{1) 4)}	W	74	74	123	111	123	123	185	185	185	185	308	308
Rated Voltage ¹⁾	V	75	75	75	75	75	75	75	75	75	75	85	85
Rated Current ¹⁾	A	1.9	1.9	2.9	2.7	3.1	3.1	3.9	3.9	4.1	4.1	5.4	5.4
Rated Output Torque ¹⁾ T _N	in-lb	104	208	174	312	174	347	260	521	260	521	434	868
	Nm	12	24	20	30	20	40	30	60	30	60	50	100
Rated Output Speed ¹⁾ n _N	rpm	60	30	60	30	60	30	60	30	60	30	60	30
Max. Continuous Stall Torque ^{1) 2) 4)}	in-lb	122	243	208	373	208	417	312	625	312	625	521	1040
	Nm	14	28	24	43	24	48	36	72	36	72	60	120
Peak Current ^{1) 2)}	A	6.2	4.8	6.4	5.0	10.7	8.8	10.0	8.3	20.6	16.3	18.2	14.4
Maximum Output Torque ^{1) 2)} T _m	in-lb	495	729	495	729	868	1390	868	1390	1910	2950	1910	2950
	Nm	57	84	57	84	100	160	100	160	220	340	220	340
Maximum Output Speed ¹⁾	rpm	80	40	80	40	80	40	80	40	80	40	80	40
Torque Constant	in-lb/A	91	182	91	182	91	182	91	199	100	189	115	231
	Nm/A	10.5	21.0	10.5	21.0	10.5	21.0	11.5	22.9	11.5	22.9	13.3	26.6
Voltage Constant (B.E.M.F.)	V/rpm	1.08	2.15	1.08	2.15	1.08	2.15	1.18	2.35	1.18	2.35	1.37	2.74
Inertia at Output Shaft ³⁾	in-lb-sec ²	2.5	10.4	4.1	16.5	4.6	18.2	9.5	39	12.2	50	27	104
	kgm ²	0.29	1.2	0.47	1.9	0.53	2.1	1.1	4.5	1.4	5.8	3.1	12.0
Mechanical Time Constant	ms	9.2	9.2	5.1	5.1	5.7	5.7	5.2	5.2	6.8	6.8	7.0	7.0
Torque-Speed Gradient	in-lb/rpm	29	115	82	326	82	326	194	779	194	779	396	1580
	Nm/rpm	3.3	13	9.3	37	93	37	22	88	22	88	37	179
Viscous Damping Constant	in-lb/rpm	0.46	2.7	0.76	3.9	0.76	4.6	1.0	5.6	0.67	5.0	0.96	6.5
	Nm/rpm	5.1·10 ⁻²	3.1·10 ⁻¹	8.6·10 ⁻²	4.4·10 ⁻¹	8.6·10 ⁻²	5.2·10 ⁻¹	1.1·10 ⁻¹	6.3·10 ⁻¹	7.6·10 ⁻²	5.6·10 ⁻¹	1.1·10 ⁻¹	7.3·10 ⁻²
Rated Power Rate ¹⁾	kW/s	0.48	0.48	0.83	0.67	0.74	0.74	0.79	0.79	0.61	0.61	0.80	0.80
Thermal Time Constant ¹⁾	min	19	19	21	21	23	23	24	24	25	25	29	29
Thermal Resistance ¹⁾	°C/W	1.14	1.14	0.99	0.99	0.93	0.93	0.76	0.76	0.71	0.71	0.51	0.51
Gear Ratio	1:R	50	100	50	100	50	100	50	100	50	100	50	100
Maximum Radial Load ³⁾	lb	309		441		661		551		992		882	
	N	RHS:1400		RFS:2000		RHS:3000		RFS:2500		RHS:4500		RFS:4000	
Maximum Axial Load	lb	309		198		661		243		992		353	
	N	RHS:1400		RFS:900		RHS:3000		RFS:1100		RHS:4500		RFS:1600	
Motor Rated Output ¹⁾	(W)	(120)	(120)	(200)	(200)	(200)	(200)	(300)	(300)	(300)	(300)	(500)	(500)
Motor Rated Speed ¹⁾	(rpm)	(3000)	(3000)	(3000)	(3000)	(3000)	(3000)	(3000)	(3000)	(3000)	(3000)	(3000)	(3000)
Armature Resistance	Ω	3.4	3.4	1.2	1.2	1.2	1.2	0.60	0.60	0.60	0.60	0.40	0.40
Armature Inductance	mH	2.7	2.7	1.1	1.1	1.1	1.1	0.92	0.92	0.92	0.92	0.84	0.84
Electrical Time Constant	ms	0.81	0.81	0.93	0.93	0.93	0.93	1.5	1.5	1.5	1.5	2.1	2.1
Starting Current	A	0.5	0.35	0.5	0.35	0.7	0.45	0.7	0.45	1.1	0.75	1.1	0.75
No-Load Running Current ⁵⁾	A	0.8	0.8	1.0	1.0	1.2	1.2	1.3	1.3	1.5	1.5	1.6	1.6
Actuator Accuracy	arc-min	1.0				1.0				1.0			
Actuator Repeatability	arc-sec	± 5				± 5				± 5			

Please Note:

- ¹⁾ The values are for saturated actuator temperature. Other values are for actuator temperature of 20°C.
- ²⁾ Maximum allowable values. Under no circumstances may these limits be exceeded.
- ³⁾ Cantilevered load applied at the midpoint of the shaft extension.
- ⁴⁾ All specifications are applicable for actuators mounted on appropriate heatsinks.
- ⁵⁾ Values are for rated output speed.

Available Motor and Gear Ratios

Actuator	RHS - 14	RHS - 17	RHS/RFS - 20	RHS/RFS - 25	RHS/RFS - 32
Ratio	50 80 100	50 80 100 120	50 80 100 120 160	50 80 100 120 160	50 80 100 120 160
Motor Power					
50	● ○ ●				
100		● ○ ● ○			
120			● ○ ● ○ ○		
200			● ○ ● ○ ○	● ○ ● ○ ○	
300				● ○ ● ○ ○	● ○ ● ○ ○
500					● ○ ● ○ ○

● = Standard ○ = Option

Performance Curves

RHS - 14 - 6003

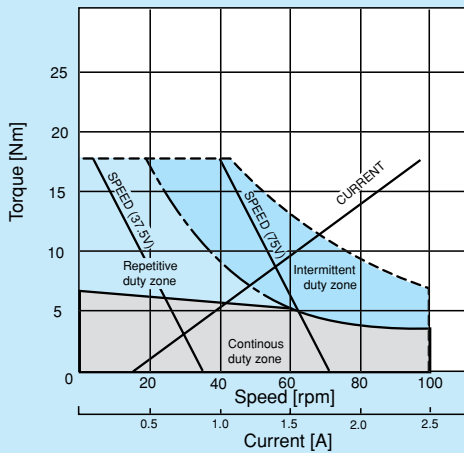

RHS - 14 - 3003

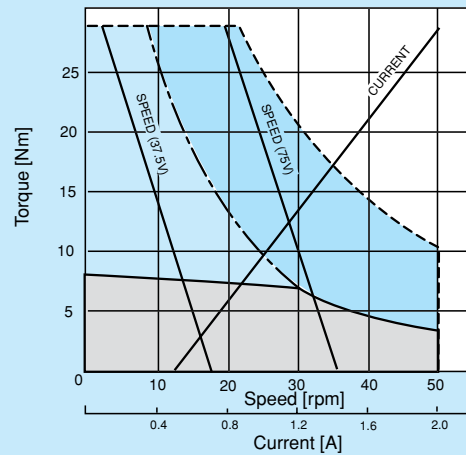

RHS - 17 - 6006

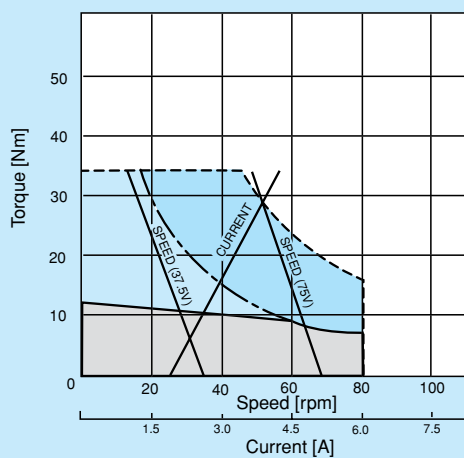

RHS - 17 - 3006

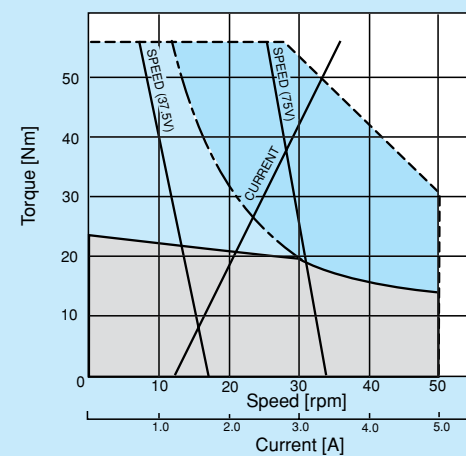



Performance Curves

RHS /RFS - 20 - 6007

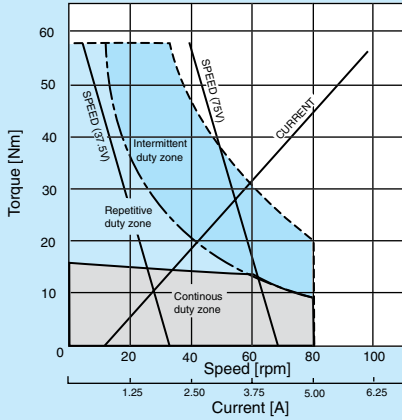

RHS /RFS - 20 - 3007

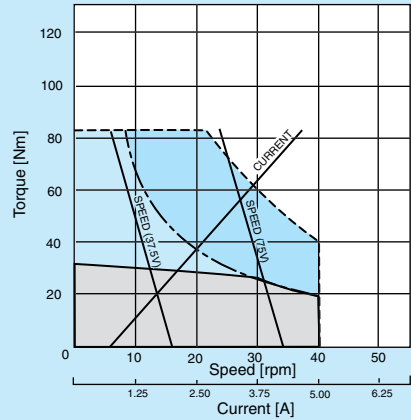

RHS /RFS - 20 - 6012

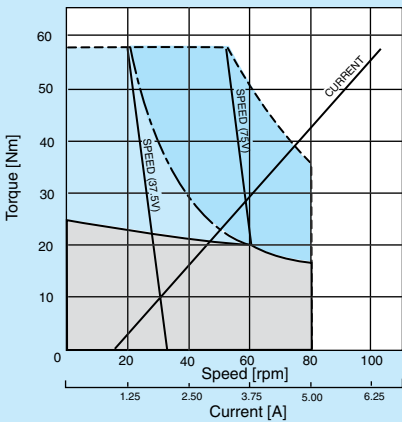

RHS /RFS - 20 - 3012

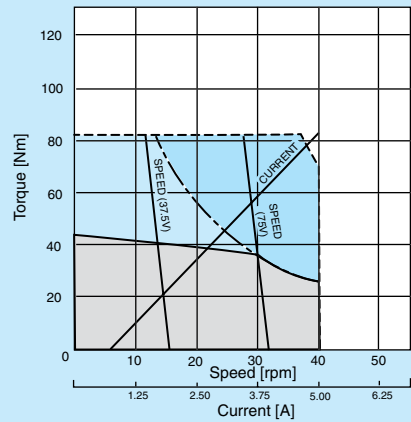

RHS /RFS - 25 - 6012

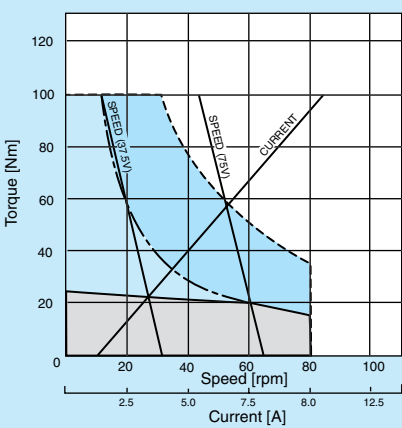

RHS /RFS - 25 - 3012

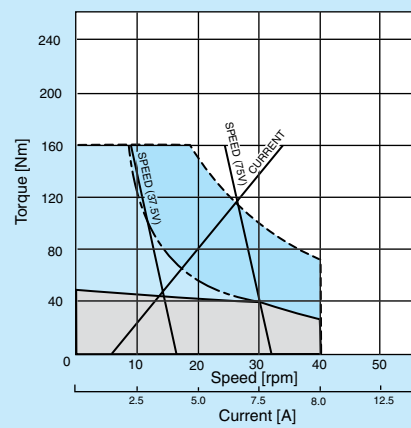



RHS /RFS - 25 - 6018

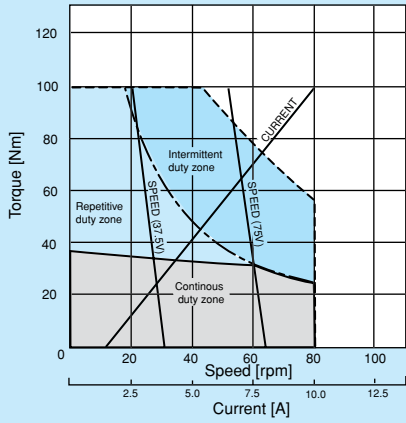

RHS /RFS - 25 - 3018

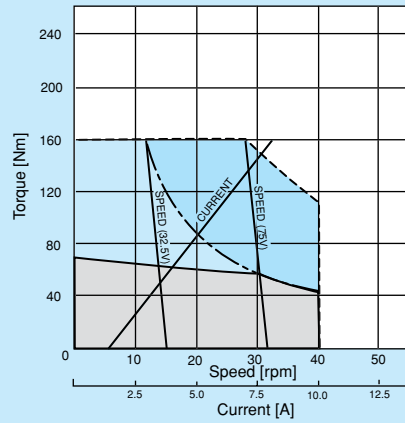

RHS /RFS - 32 - 6018

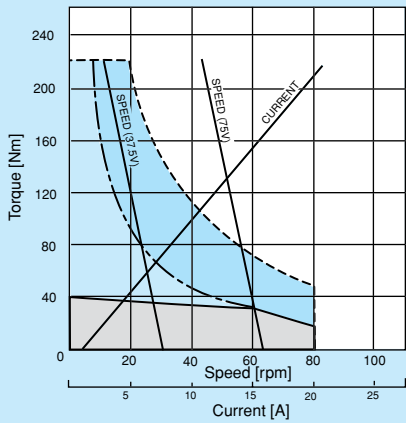

RHS /RFS - 32 - 3018

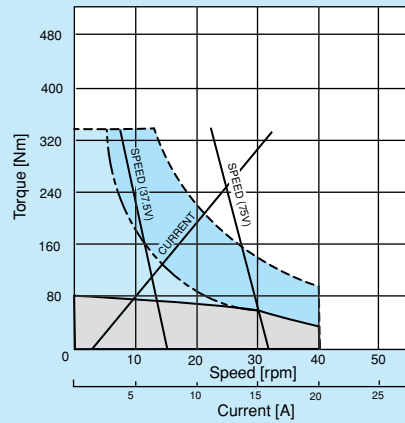

RHS /RFS - 32 - 6030

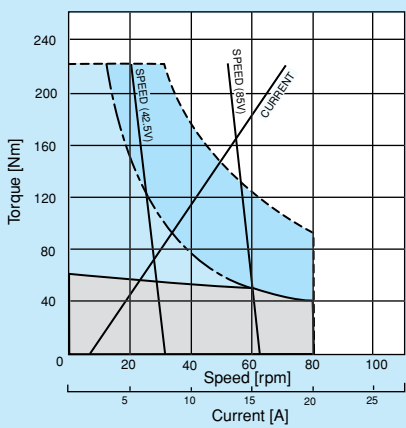

RHS /RFS - 32 - 3030

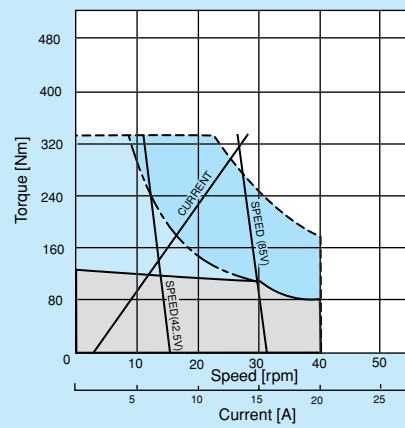

Duty Cycle Characteristics

When an actuator is repeatedly operated above the rated torque and speed for periods of 0.1 minute or more, the minimum idle time required to prevent damage from overheating can be calculated from the graphs on this page once the load factor and the duty factor have been established.

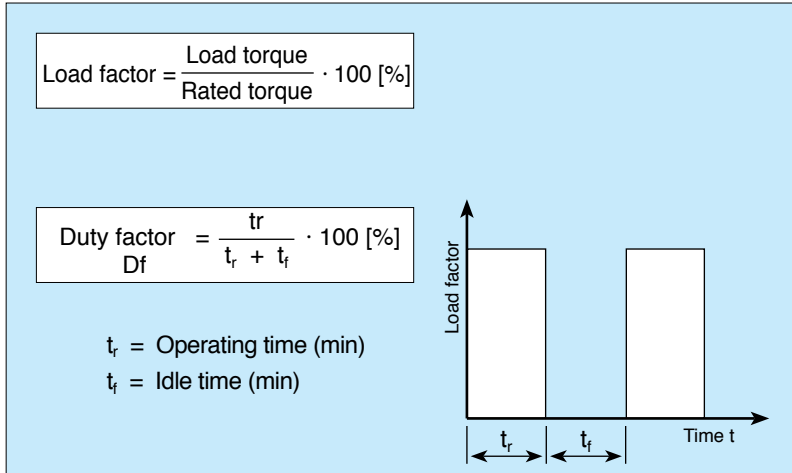

Example: RHS-25-6018

Assume a load factor of 150% for a duration of 3 minutes. As indicated on the graphs below (Overload Duty Cycle Performance Curve), the duty cycle of RHS-25-6018 actuator is approximated at 30%.

The required idle time for operating the actuator under these conditions is calculated as follows:

$$t_i = \frac{t_r}{Df} - t_r = \frac{3}{.3} - 3 = 7 \text{ minutes}$$

Therefore, the actuator must be turned off for 7 minutes when it has been operated for 3 minutes under a 150% load factor.

Loading Curves

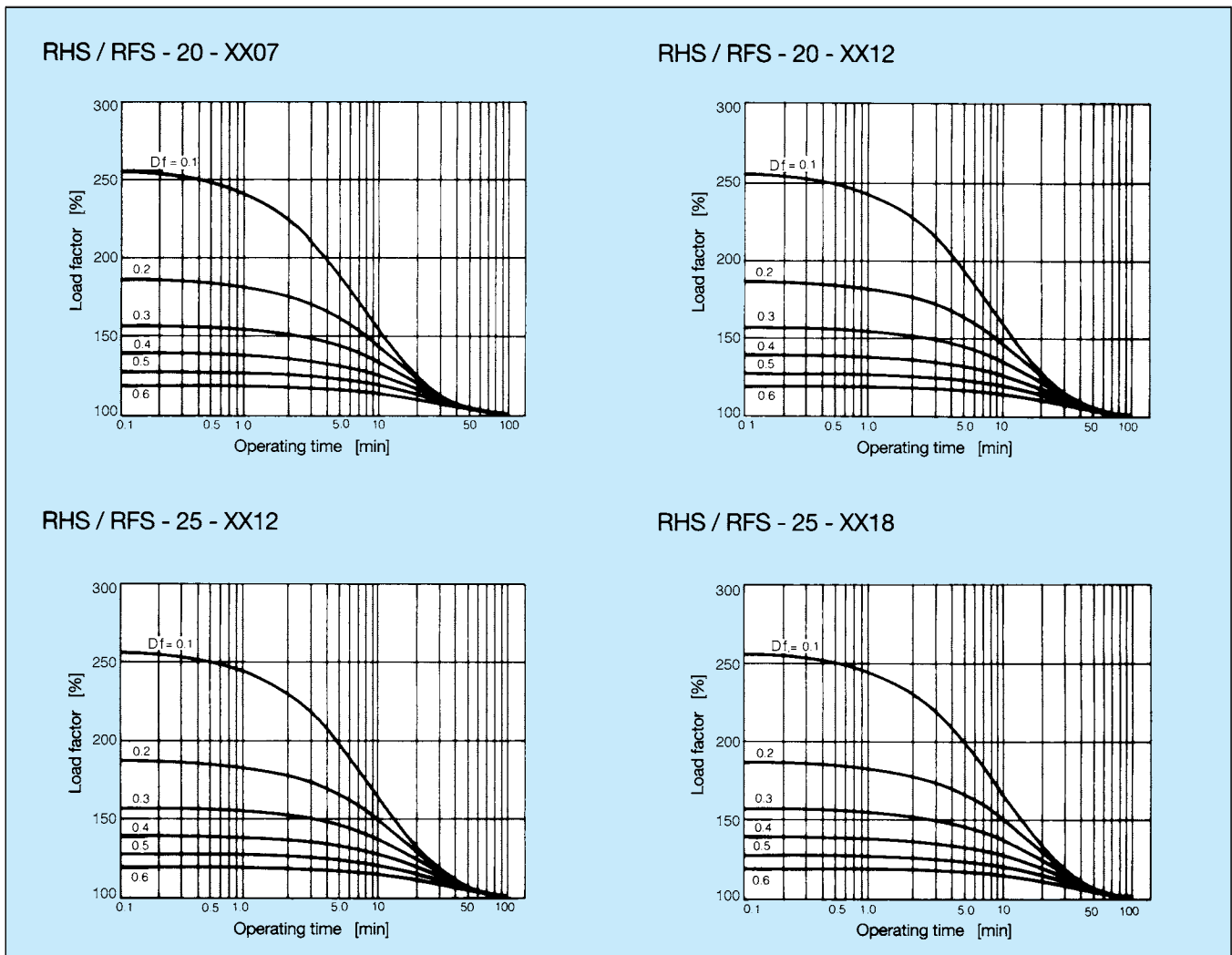



RHS / RFS - 32 - XX18

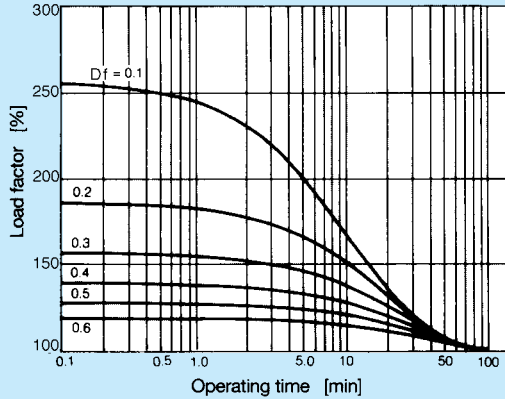

RHS / RFS - 32 - XX30

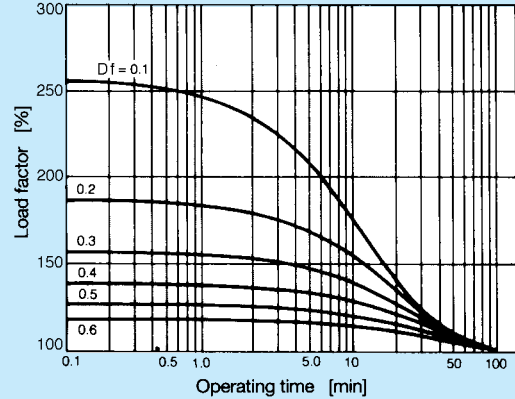

Please Note:

In the Figs., a segment represented by a broken line is beyond the maximum torque of the actuator. This part of the loading curve should not be used.

Precautions When Selecting Control Units

If you choose a control unit other than Harmonic Drive LLC control units, confirm the following items to prevent possible damage to the actuator from overheating.

◆ Current Limit

When operating the actuator below the rated torque, the amplifier must be able to limit the maximum current that is available to the motor.

◆ Overload Protection Function

When operating the actuator above the rated torque, an appropriate overload protection function is required to keep the current overload time within the allowable region of the overload duty cycle performance curve for the actuator.

Motor

Polarity

The output shaft rotation is clockwise (when viewed from the output shaft of the actuator), when the voltage applied to the white motor lead is positive with respect to the black lead.

Motor Lead Wires

Table 16

Actuator	wire	
	length (m)	c. s. area (mm ²)
RHS - 14	1	0.75
RHS - 17	1	0.75
RHS / RFS-20	1	1.25
RHS / RFS-25	1	1.25
RHS / RFS-32	1	1.25

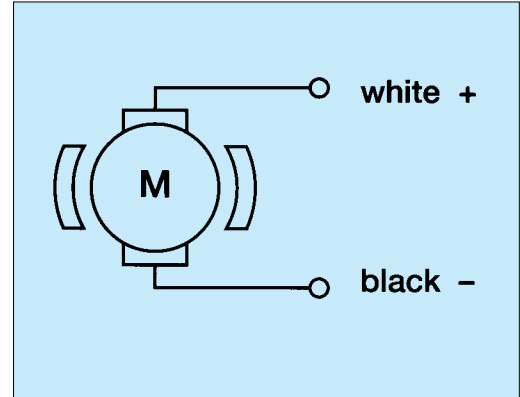

Tach-Generator

Polarity

When the output shaft rotation is clockwise (when viewed from the output shaft of the actuator), the polarity of the white tach lead is positive and the red lead negative.

Table 17

Output Voltage	7 V \pm 10% / 1000 rpm
Ripple (RMS) ¹⁾	3% max.
Linearity ¹⁾	\pm 1% max.
Armature Resistance	25 Ω \pm 10% (at 20°C)
Armature Inductance	4 mH
Moment of Inertia ²⁾	1 x 10 ⁻⁵ kgm ²

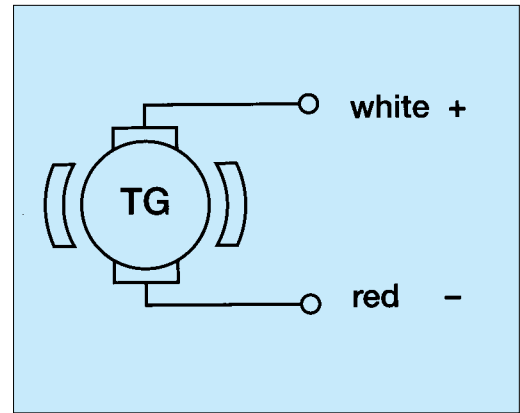

Please note:

- ¹⁾ This value refers to the tach-generator only.
- ²⁾ This value is referred to the motor shaft. For the moment of inertia referred to the actuator output shaft multiply this value by the square of the reduction ratio.

Tach-Generator Lead Wires

Table 18

Actuator	wire	
	length (m)	c. s. area (mm ²)
RHS - 14	1	0.3
RHS - 17	1	0.3
RHS / RFS-20	1	0.3
RHS / RFS-25	1	0.3
RHS / RFS-32	1	0.3

Testing Circuit for Output Voltage, Linearity and Ripple:

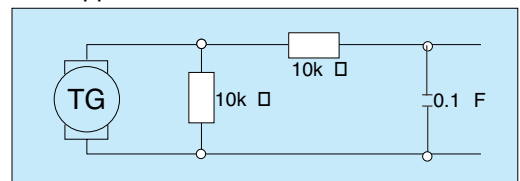

Encoder

Table 19

Output Circuit		Open Collector DO	Line Driver AL	Line Driver BL
Resolution ¹⁾	P/rev	200, 360, 500, 1000, 1024	200, 360, 500, 1000, 1024	200, 360, 500, 1000, 1024
Output Signal		A, B, Z	A, \bar{A} , B, \bar{B} , Z, \bar{Z}	A, A, B, \bar{B} , Z, \bar{Z}
Power Supply ²⁾	V DC	+ 4.75 ~ +12.6 (80 mA max.)	+ 5 \pm 5% (160 mA max.)	+ 7 ~ + 12 (160 mA max.)
Output Voltage V _{OL} , V _{OH}	V	0.5 max. , -	0.5 max. , 2.5 min.	0.5 max. , 2.5 min.
Max. Voltage V _{CC}	VDC	+ 24	-	-
Max. Current I _{OL}	mA	20 max.	20 max.	20 max.
Max. Response Frequency	kHz	100	100	100
Moment of Inertia ³⁾	kgm ²	1 x 10 ⁻⁶	1 x 10 ⁻⁶	1 x 10 ⁻⁶

Please note:

- ¹⁾ Resolution of encoder only. Resolution at the output of the actuator is equal to the encoder resolution multiplied by the reduction ratio.
- ²⁾ 12 V DC is recommended in case of a cable length longer than 10 meters.
- ³⁾ Value at motor shaft. To convert it to the value at the output of the actuator, multiply by the square of the reduction ratio.

Encoder Lead Wires

Table 20

Color	Line Driver	Open Collector
Brown	A-Signal	A-Signal Output
Blue	\bar{A} -Signal	A-Signal Common
Red	B-Signal	B-Signal Output
Green	\bar{B} -Signal	B-Signal Common
Yellow	Z-Signal	Z-Signal Output
Orange	\bar{Z} -Signal	Z-Signal Common
White	Power Supply	Power Supply
Black	Common	Common
Shield	Floating	Floating

Lead Wires:

(Open Collector and Line Driver)

Table 21

Actuator	length (m)	c. s. area (mm ²)	Diameter (mm)
RHS-14	1	0.14	5.5
RHS-17	1	0.14	5.5
RHS/RFS-20	1	0.14	5.5
RHS/RFS-25	1	0.14	5.5
RHS/RFS-32	1	0.14	5.5

Open Collector DO

● Output Circuit

Encoder Side

A, B, Z

Output Signal

COM

$V_{cc} = +5V \sim 12V$
 $I_{OL} = 20mA \text{ Max.}$

● Output Wave Form

A Signal

B Signal

Z Signal

$T = \text{Average cycle}$
 $a, b, c, d = 0.25T \pm 0.1T$
 $e = 0.5T \pm 0.1T$
 $\Delta T \leq 0.05T$
Z Signal is synchronized with A Signal

CW facing mounting end

Line Driver

● Output Circuit

Encoder side

Shield or common ground
 $R_T = 150\Omega$ (terminator resistance)
IC: Am26LS32 (or equivalent)

● Output Wave Form

A Signal

\bar{A} Signal

B Signal

\bar{B} Signal

Z Signal

\bar{Z} Signal

$T = \text{Average cycle}$
 $a, b, c, d = 0.25T \pm 0.1T$
 $e = 0.5T \pm 0.1T$
 $\Delta T \leq 0.05T$
Z Signal is synchronized with A Signal

CW facing mounting end

Wiring of Tach-Generator and Encoder

Table 22

Color	Tach-Generator	Encoder	
		Line Driver	Open Collector
Brown	—	A-Signal	A-Signal Output
Blue	—	\bar{A} -Signal	A-Signal Common
Red	—	B-Signal	B-Signal Output
Green	—	\bar{B} -Signal	B-Signal Common
Yellow	—	Z-Signal	Z-Signal Output
Orange	—	\bar{Z} -Signal	Z-Signal Common
White	—	Power Supply	Power Supply
Black	—	Common	Common
Shield	—	Floating	Floating
White-Black (thick)	Plus Output ¹⁾	—	—
Red-Black (thick)	Minus Output ¹⁾	—	—

¹⁾ Polarity at CW facing mounting end. These thick wires are lead wires of the tach-generator.

Weights

kg

Table 23

Actuator	Gearbox and Motor	Including Tach	Including Encoder	Including Tach and Encoder
RHS-14-XX03	1.7	1.9	1.9	2.1
RHS-17-XX06	2.7	2.9	2.9	3.1
RHS-20-XX07	3.3	3.8	3.6	4.0
RHS-20-XX12	3.9	4.4	4.2	4.6
RHS-25-XX12	5.4	5.9	5.7	6.1
RHS-25-XX18	6.1	6.6	6.4	6.8
RHS-32-XX18	9.4	9.9	9.7	10.1
RHS-32-XX30	11.1	11.6	11.4	11.8
RFS-20-XX07	3.3	3.8	3.6	4.0
RFS-20-XX12	3.9	4.4	4.2	4.6
RFS-25-XX12	5.4	5.9	5.7	6.1
RFS-25-XX18	6.1	6.6	6.4	6.8
RFS-32-XX18	9.5	10.0	9.8	10.2
RFS-32-XX30	11.2	11.7	11.5	11.9

Output Shaft and Flange Tolerances

The following tables provide the geometric tolerances for the output shaft and flange.

RHS Series (Output shaft)

Table 24

Actuator	Concentricity \odot a	Perpendicularity \perp b	Run-out \nearrow c
14	0.06	0.06	0.04
17	0.06	0.06	0.04
20	0.06	0.06	0.04
25	0.06	0.06	0.04
32	0.06	0.06	0.04

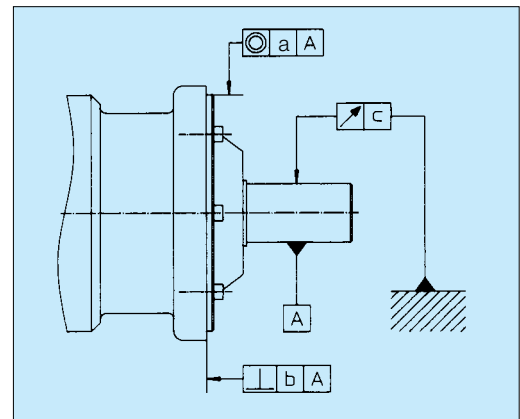

RFS Series (Output flange)

Table 25

Actuator	Concentricity \odot a	Perpendicularity \perp b	Perpendicularity \perp c	Run-out \nearrow d
20	0.05	0.05	0.03	0.03
25	0.05	0.05	0.03	0.03
32	0.05	0.05	0.03	0.03

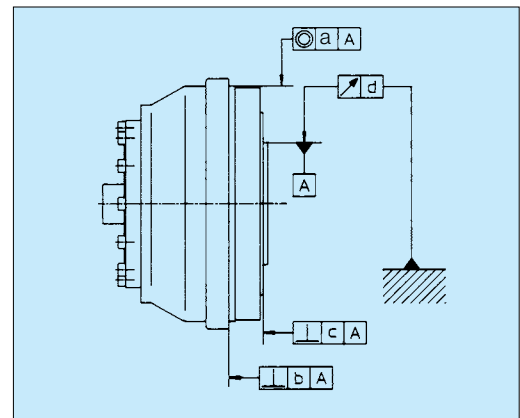

Connecting the actuator to the load

RHS Series actuators are provided with a smooth output shaft. To connect the actuator to the load, we recommend the use of clamping assemblies or clamping elements, as shown in the figures below.

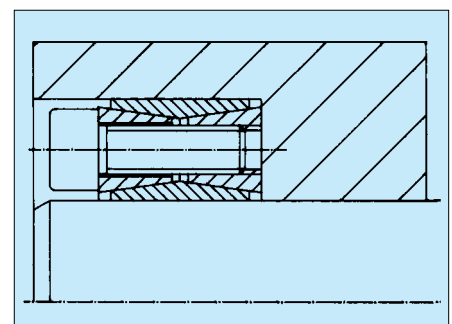
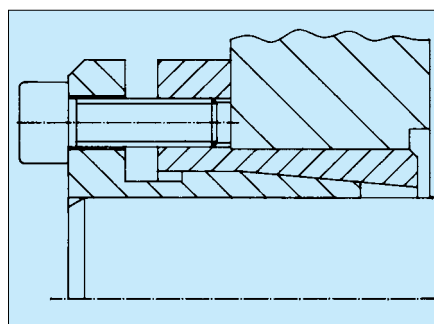
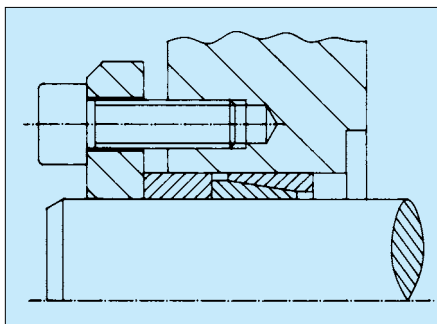

Outline and Dimensions

mm

RHS-14-XX03 Actuator Only

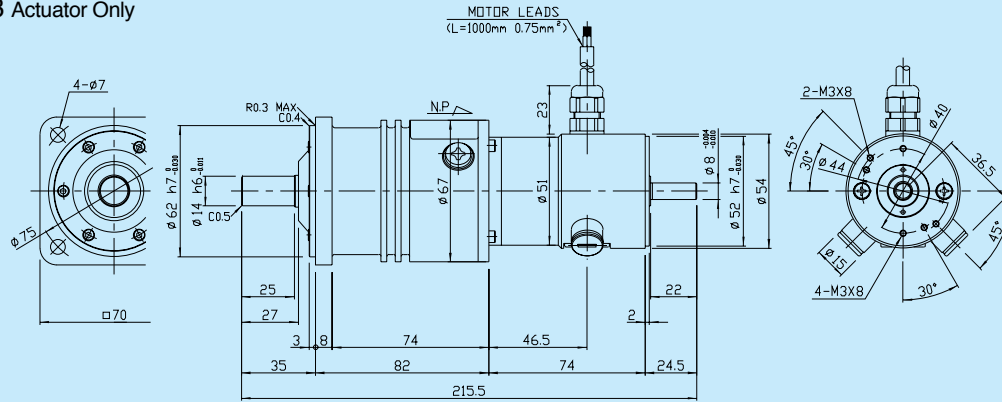

RHS-14-XX03-T With Tach-Generator

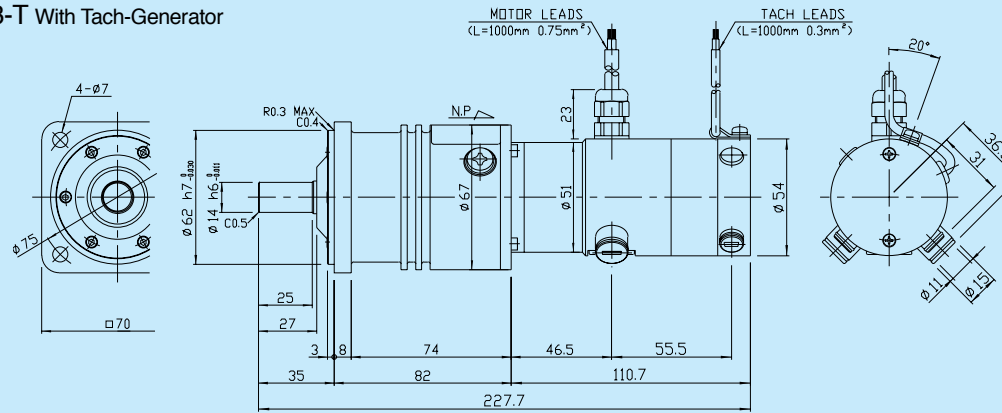

RHS-14-XX03-E With Encoder

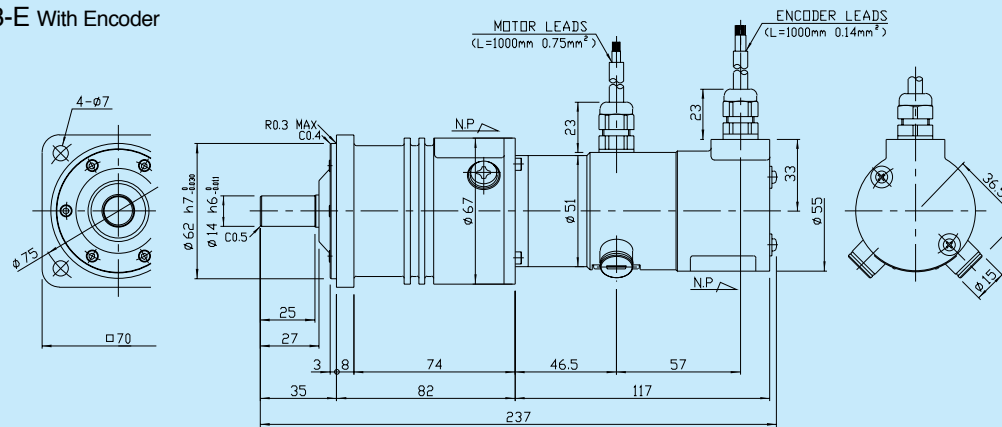

RHS-14-XX03-TE With Tach-Generator and Encoder

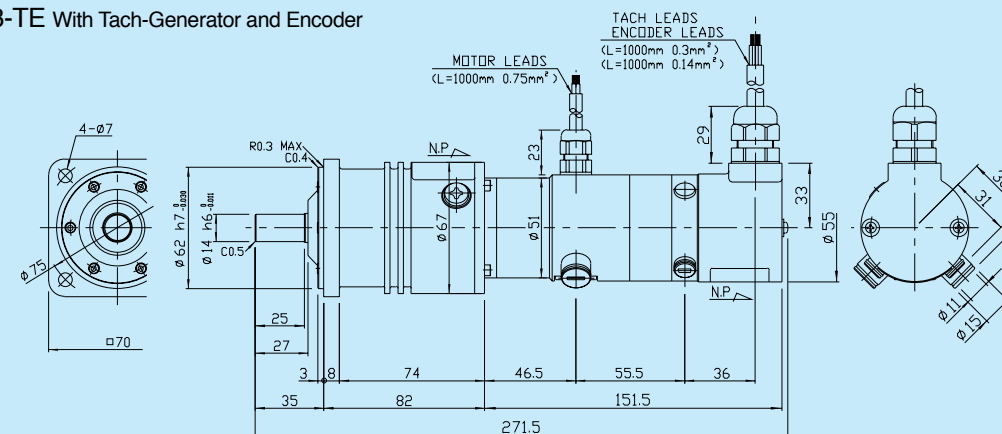

RHS-17-XX06 Actuator Only

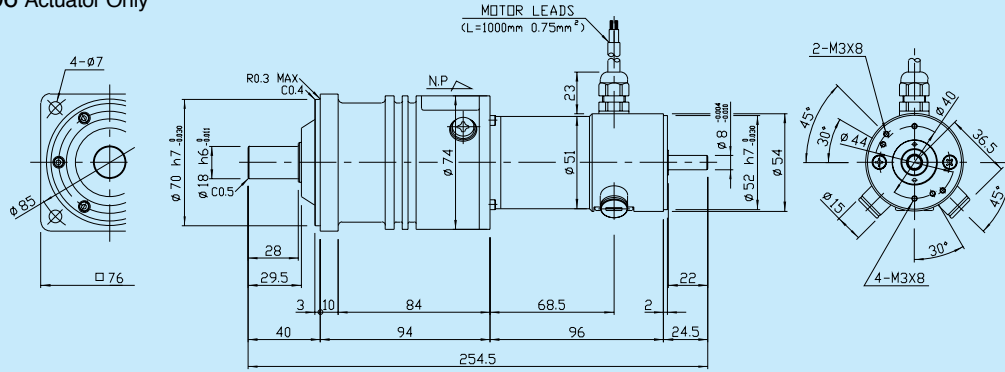

RHS-17-XX06-T With Tach-Generator

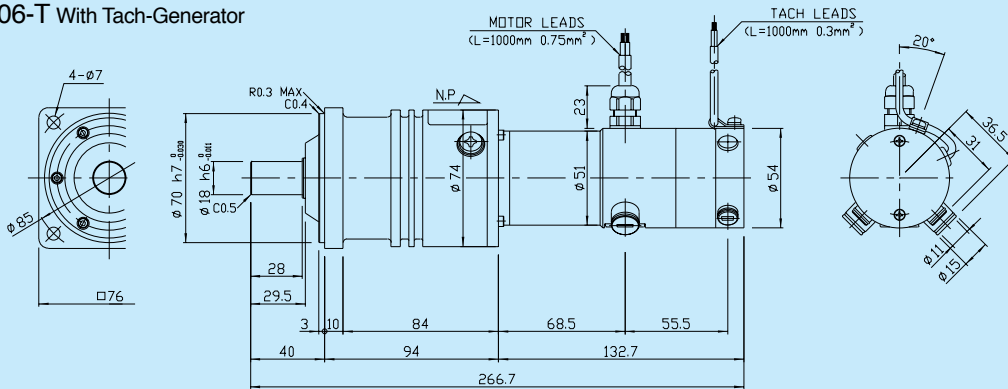

RHS-17-XX06-E With Encoder

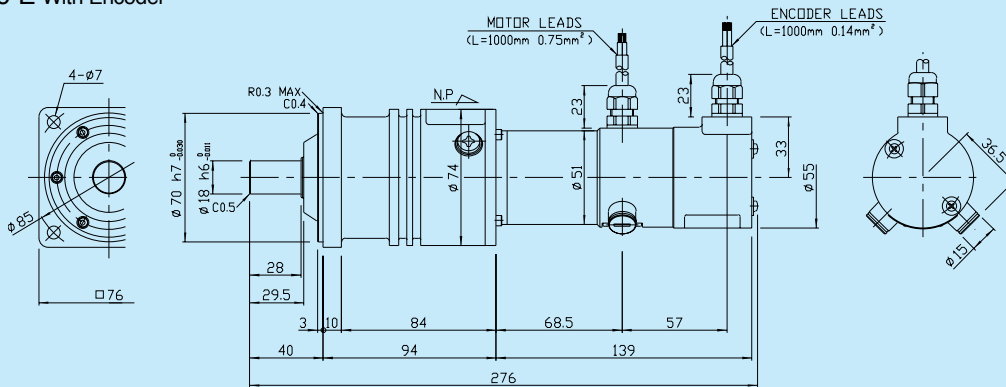

RHS-17-XX06-TE With Tach-Generator and Encoder

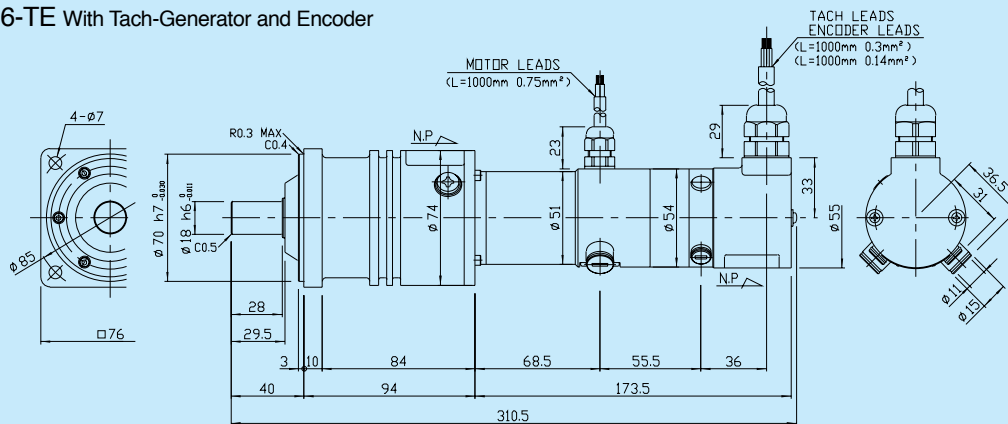

Outline and Dimensions

mm

RHS-20-XX07 Actuator Only

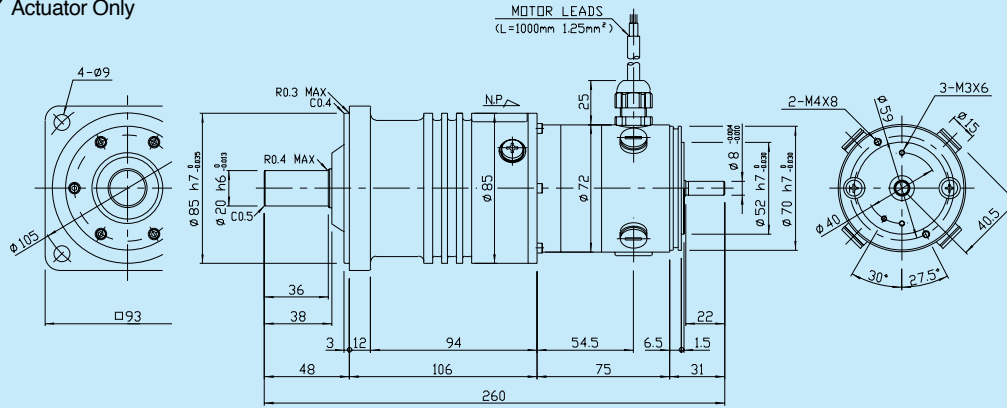

RHS-20-XX07-T With Tach-Generator

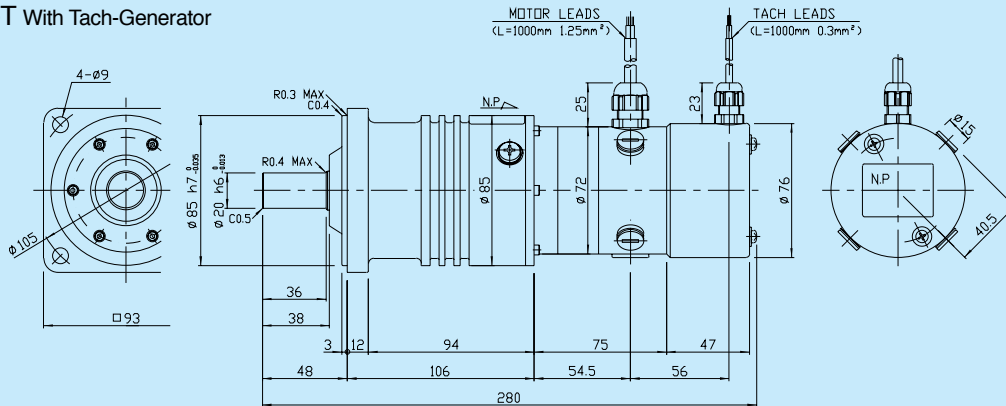

RHS-20-XX07-E With Encoder

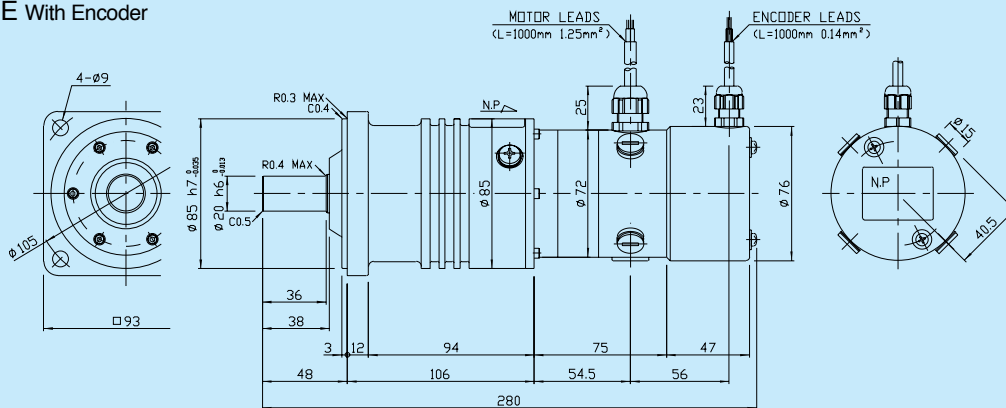

RHS-20-XX07-TE With Tach-Generator and Encoder

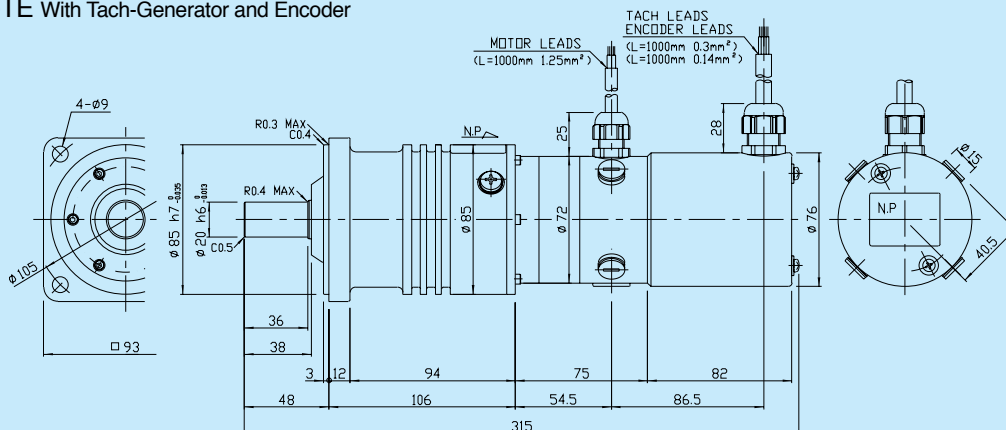

RHS-20-XX12 Actuator Only

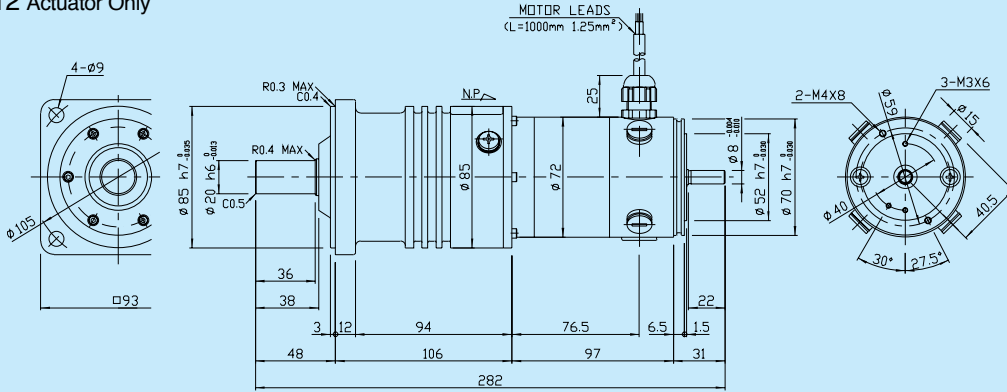

RHS-20-XX12-T With Tach-Generator

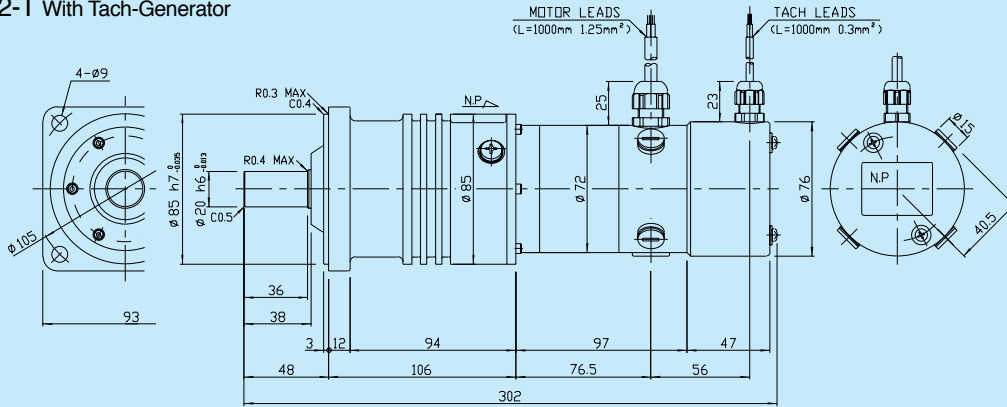

RHS-20-XX12-E With Encoder

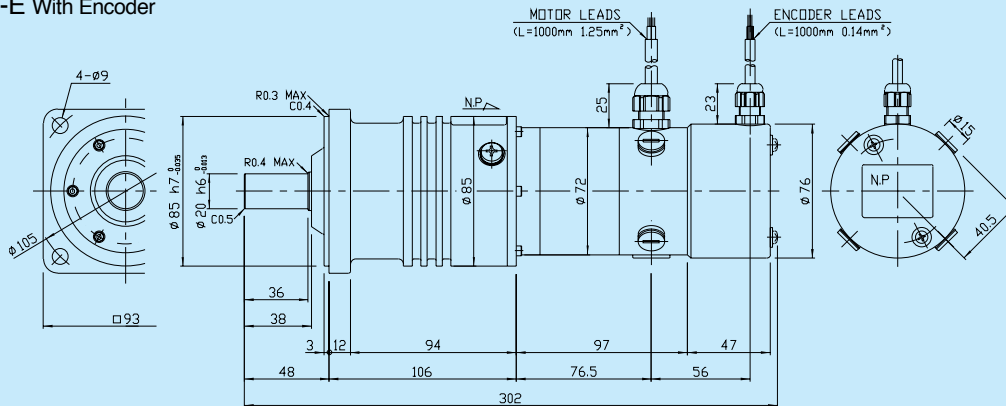

RHS-20-XX12-TE With Tach-Generator and Encoder

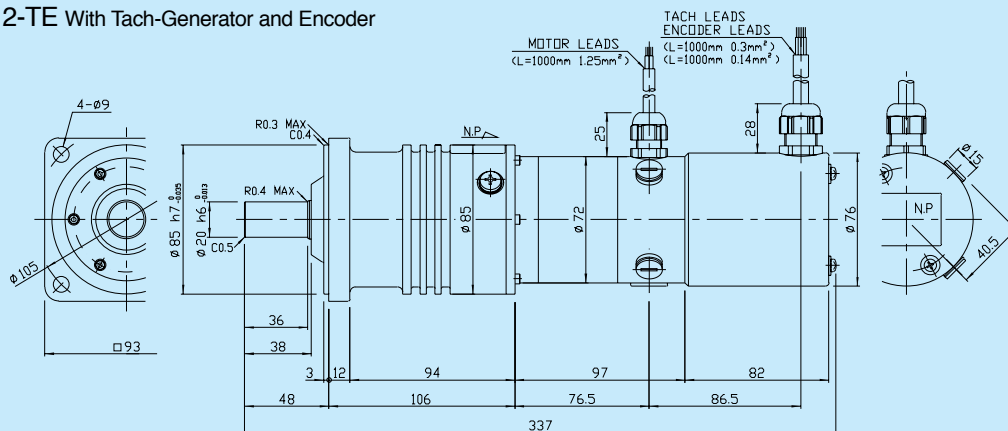

Outline and Dimensions

mm

RHS-25-XX12 Actuator Only

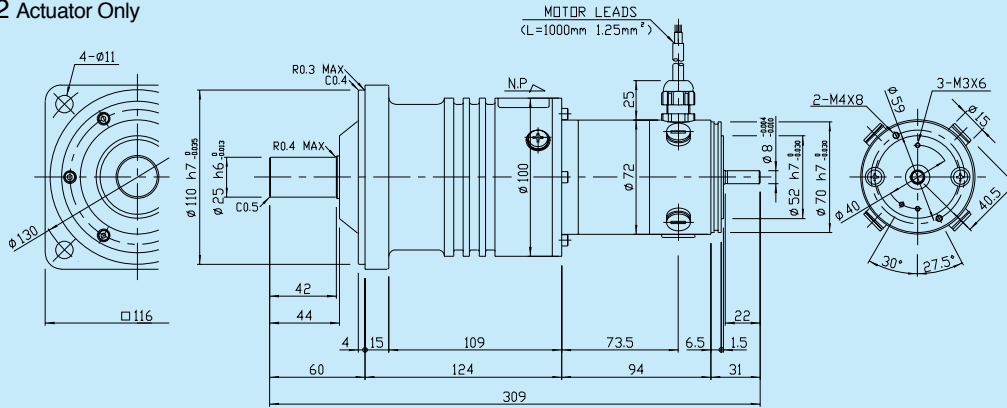

RHS-25-XX12-T With Tach-Generator

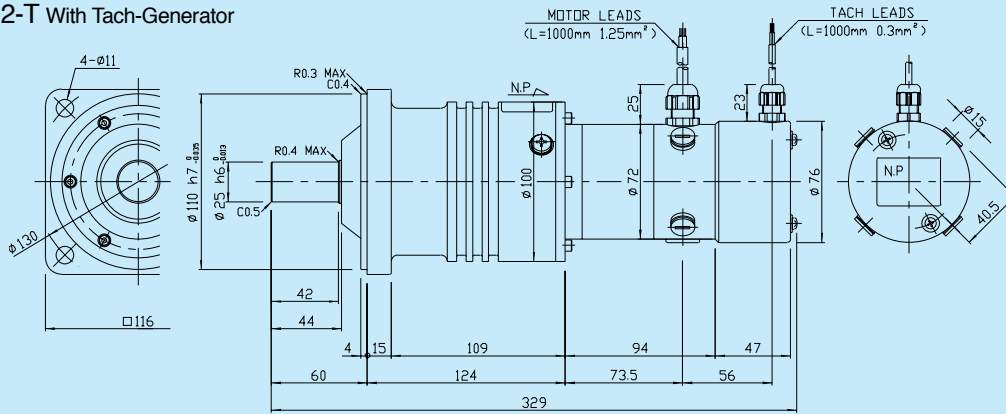

RHS-25-XX12-E With Encoder

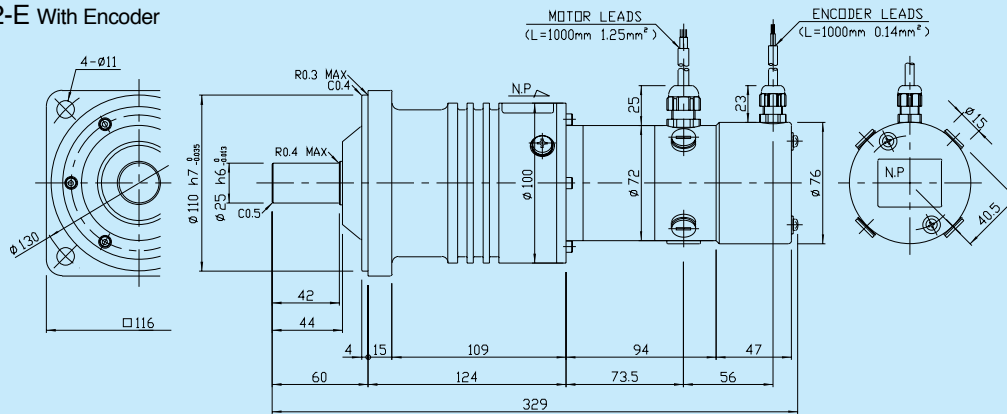

RHS-25-XX12-TE With Tach-Generator and Encoder

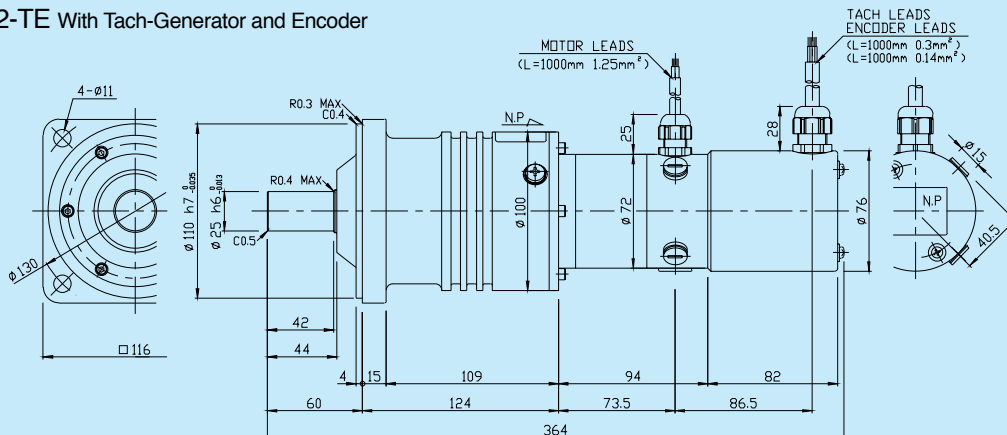

RHS-25-XX18 Actuator Only

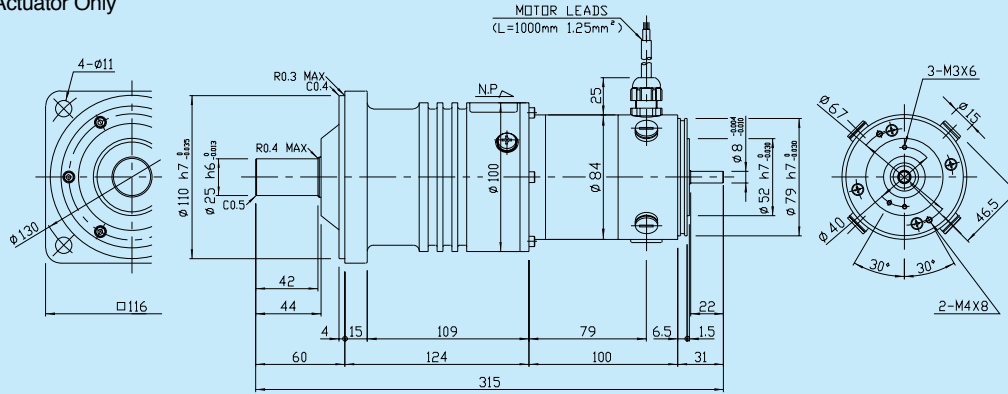

RHS-25-XX18-T With Tach-Generator

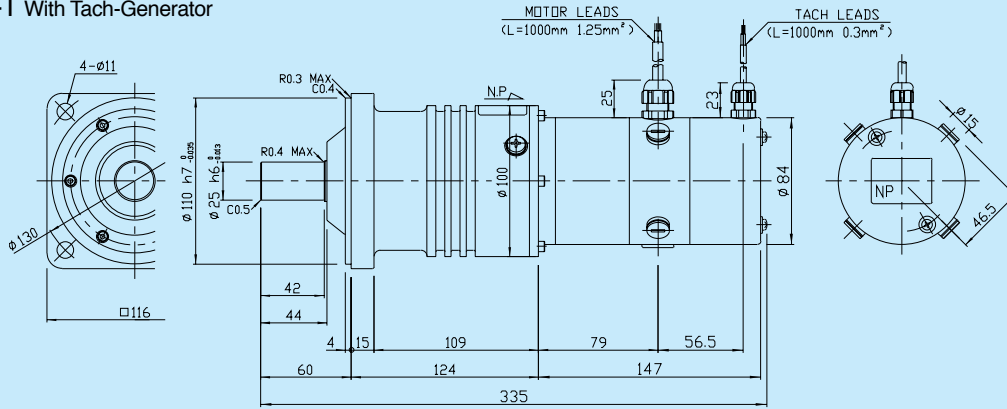

RHS-25-XX18-E With Encoder

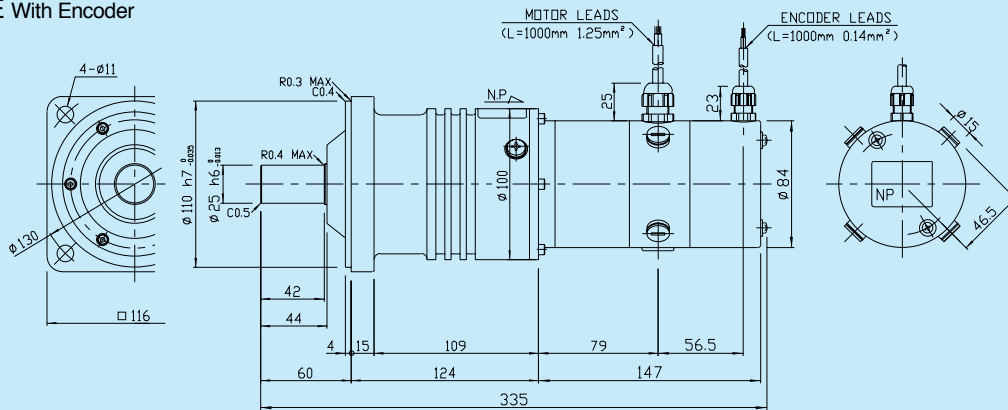

RHS-25-XX18-TE With Tach-Generator and Encoder

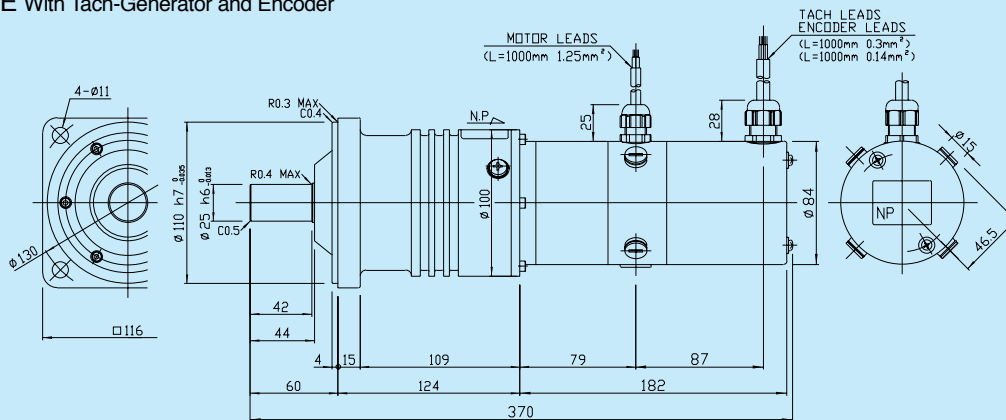

Outline and Dimensions

mm

RHS-32-XX18 Actuator Only

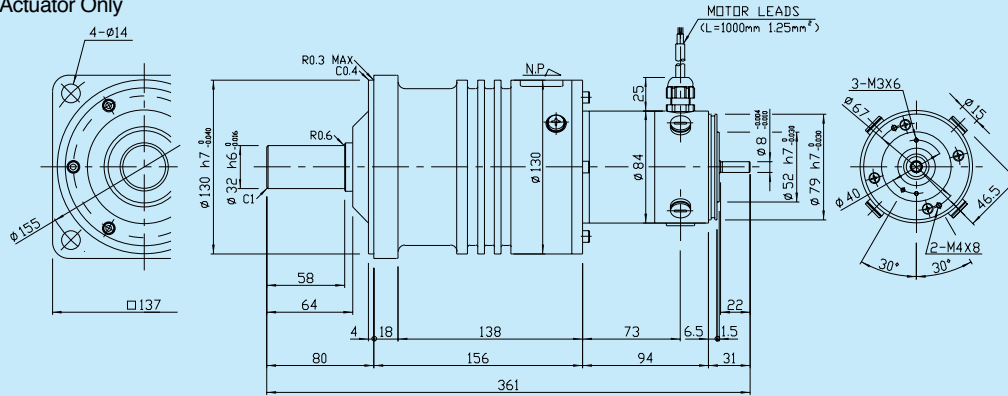

RHS-32-XX18-T With Tach-Generator

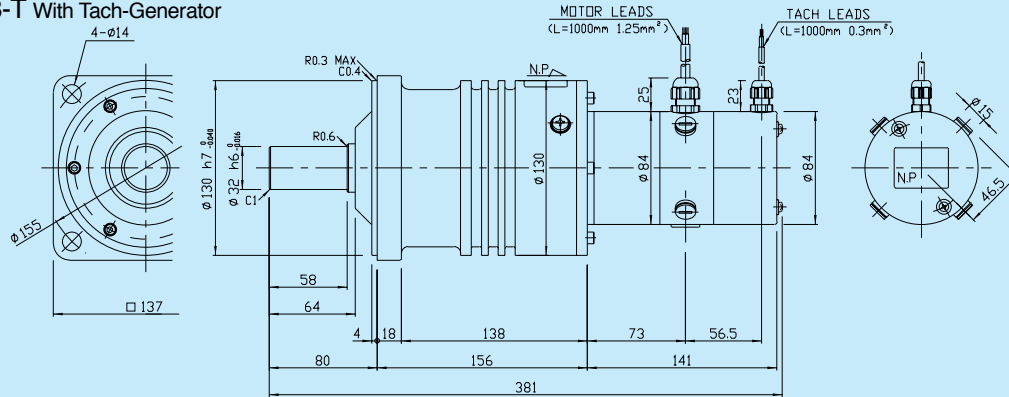

RHS-32-XX18-E With Encoder

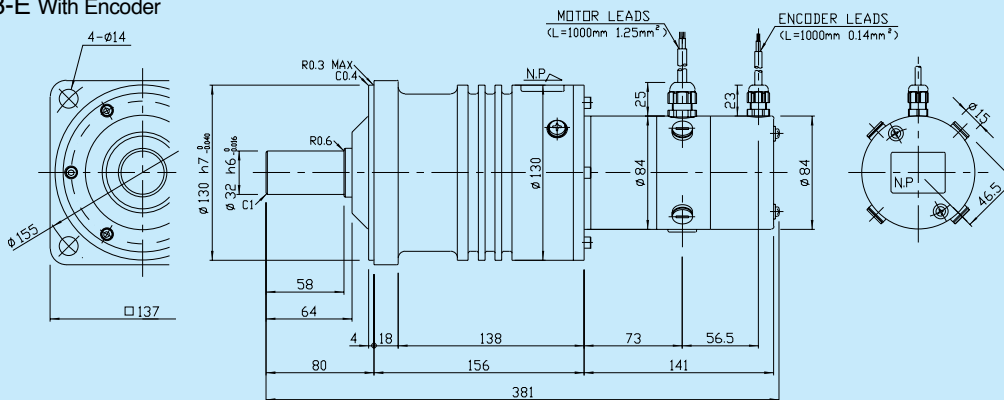

RHS-32-XX18-TE With Tach-Generator and Encoder

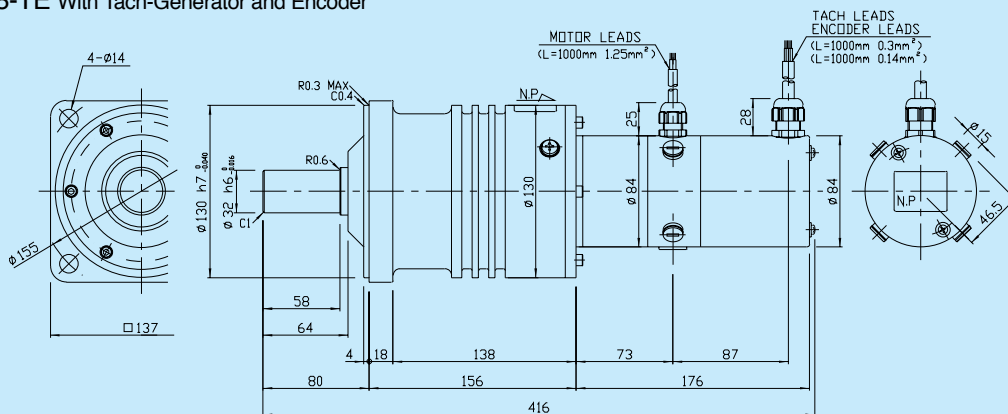

RHS-32-XX30 Actuator Only

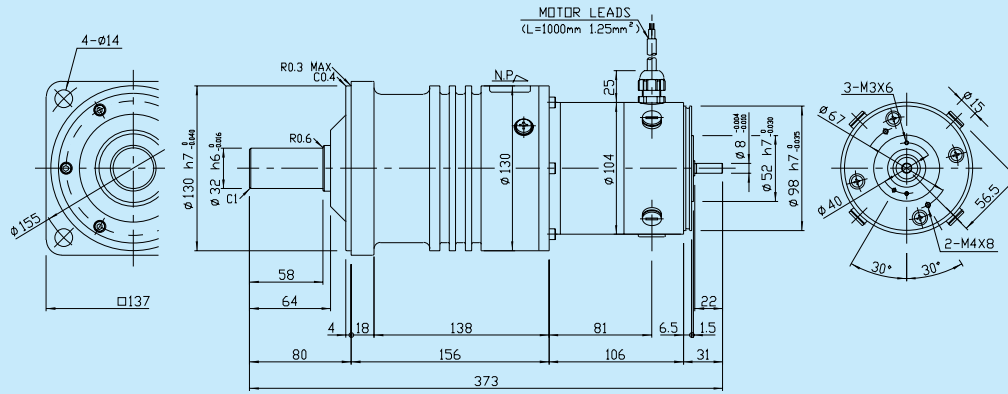

RHS-32-XX30-T With Tach-Generator

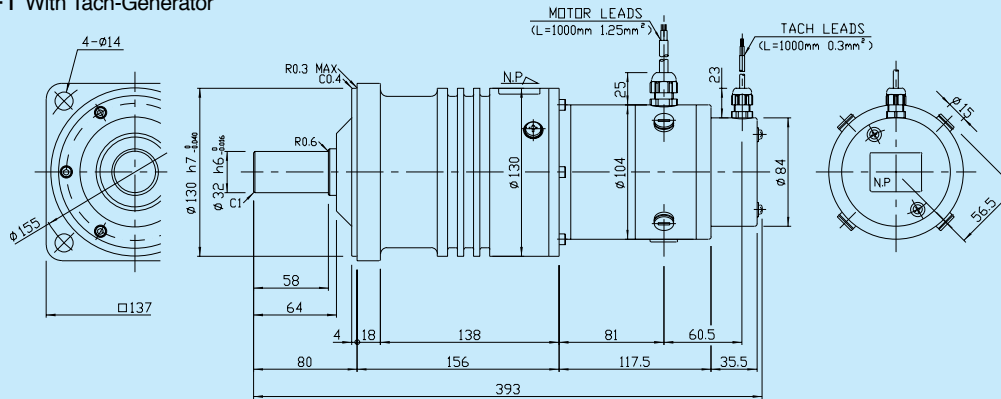

RHS-32-XX30-E With Encoder

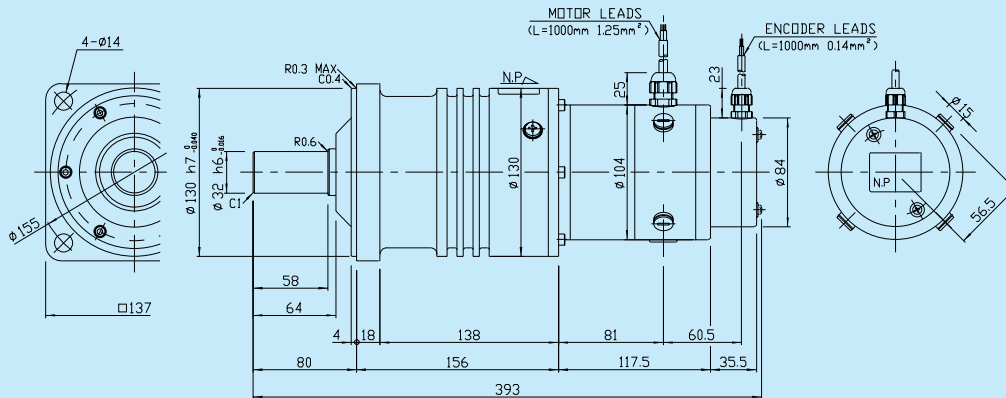

RHS-32-XX30-TE With Tach-Generator and Encoder

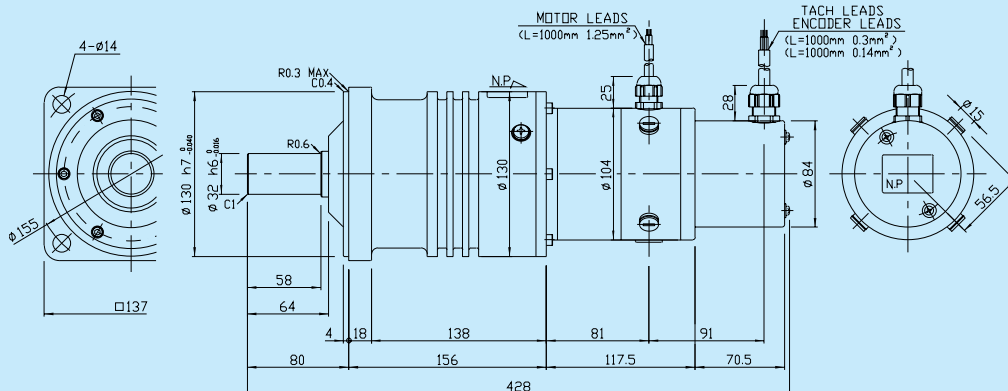

Outline and Dimensions

mm

RFS-20-XX07 Actuator Only

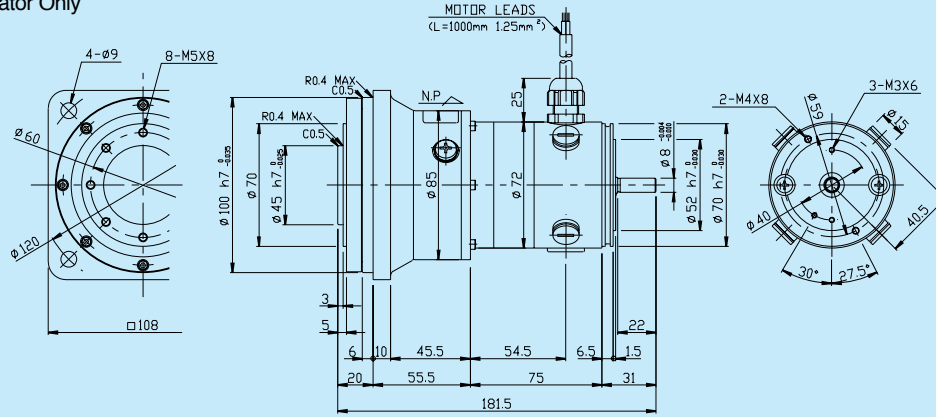

RFS-20-XX07-T With Tach-Generator

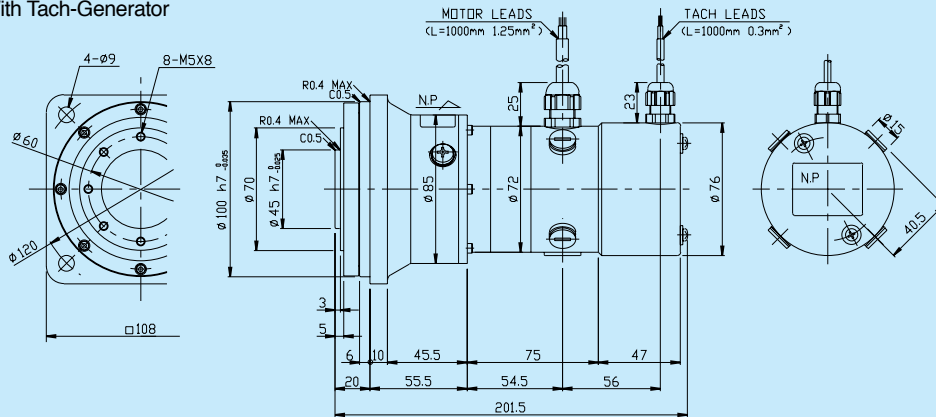

RFS-20-XX07-E With Encoder

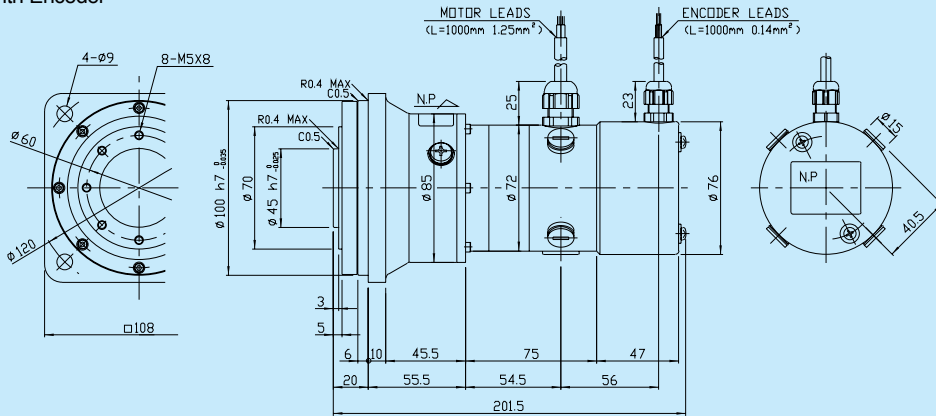

RFS-20-XX07-TE With Tach-Generator and Encoder

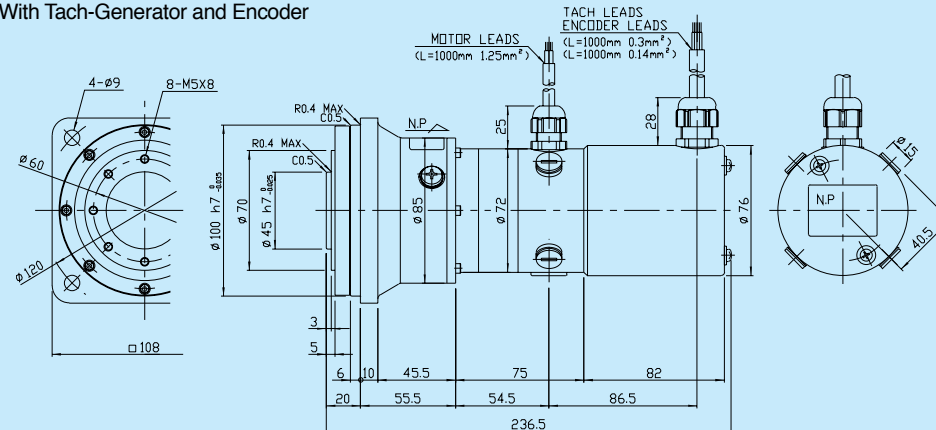

RFS-20-XX12 Actuator Only

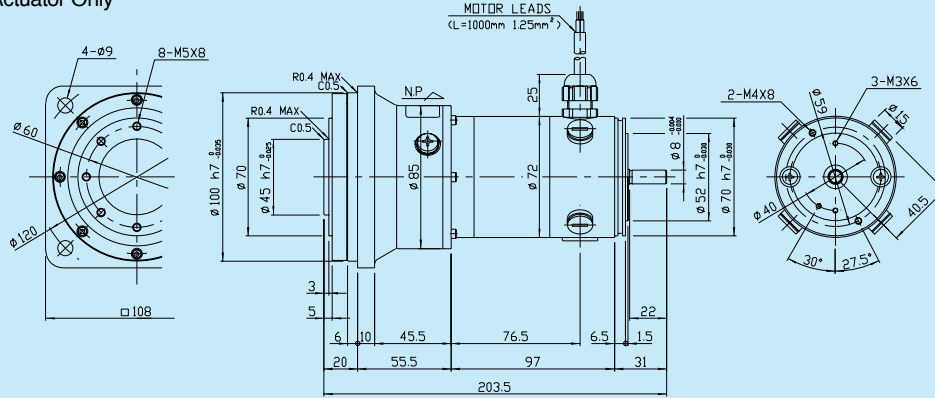

RFS-20-XX12-T With Tach-Generator

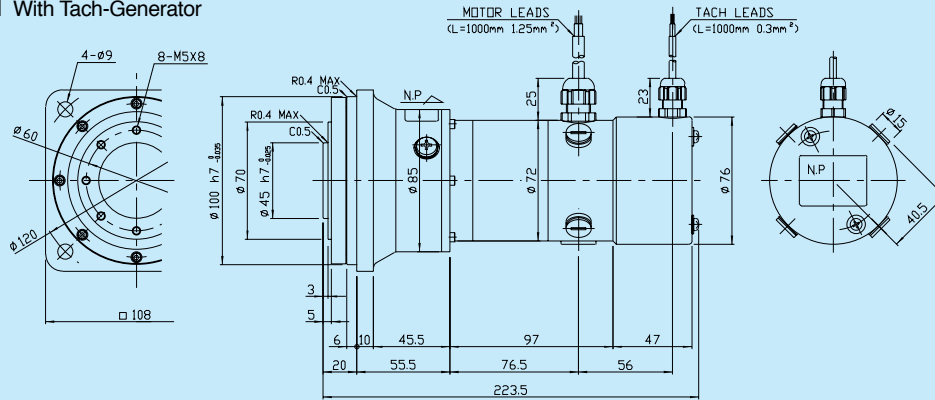

RFS-20-XX12-E With Encoder

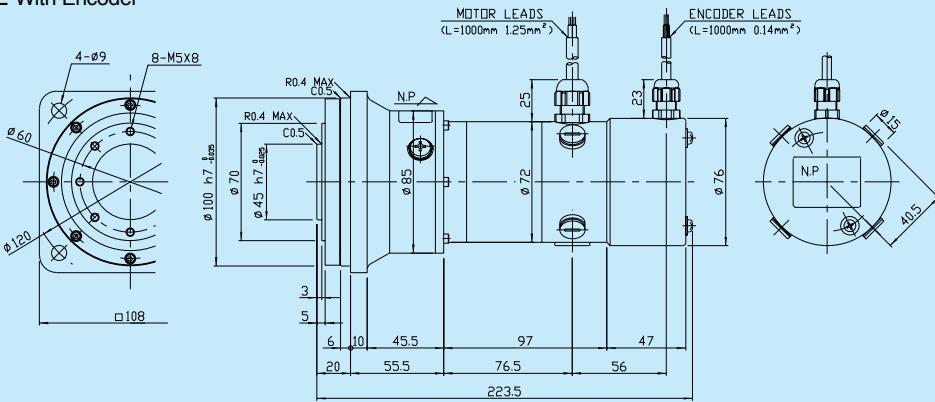

RFS-20-XX12-TE With Tach-Generator and Encoder

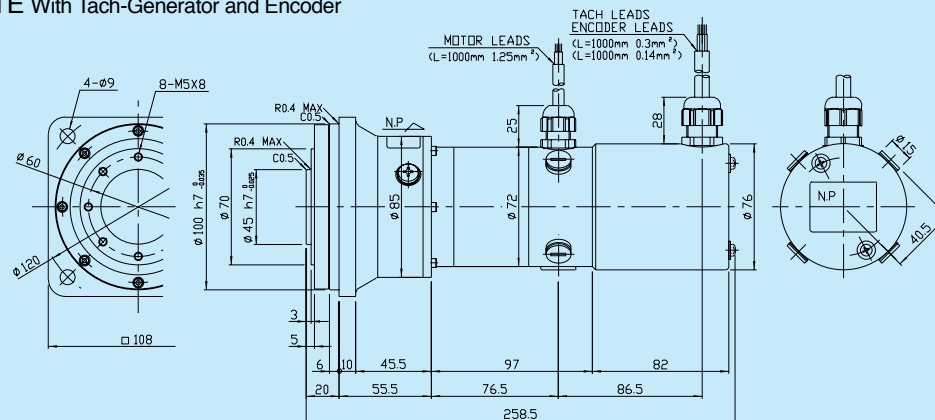

Outline and Dimensions

mm

RFS-25-XX12 Actuator Only

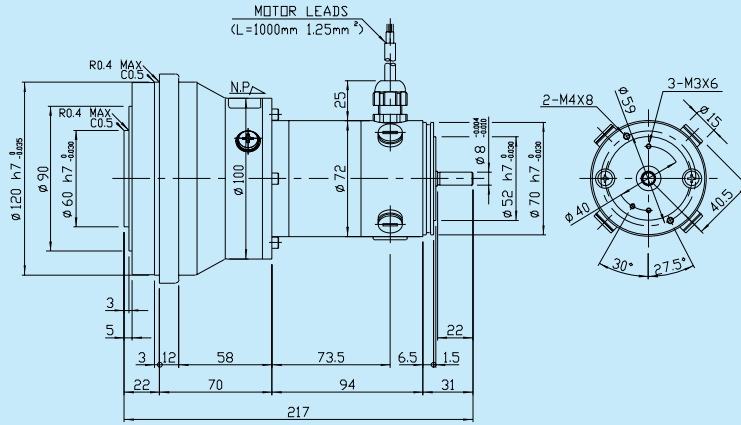
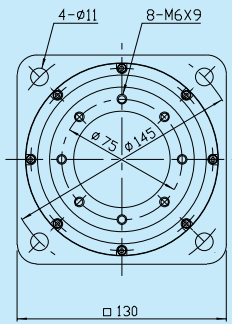

RFS-25-XX12-T With Tach-Generator

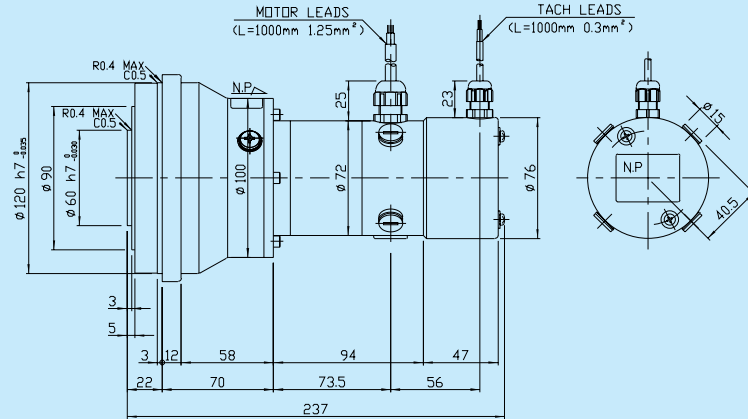
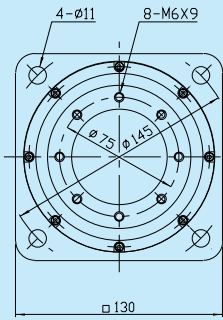

RFS-25-XX12-E With Encoder

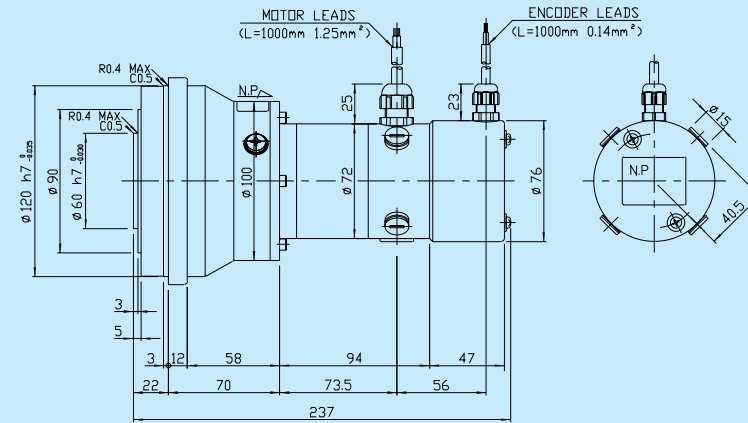
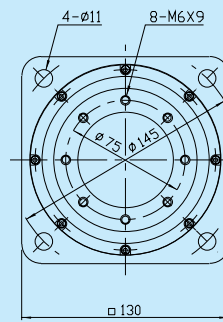

RFS-25-XX12-TE With Tach-Generator and Encoder

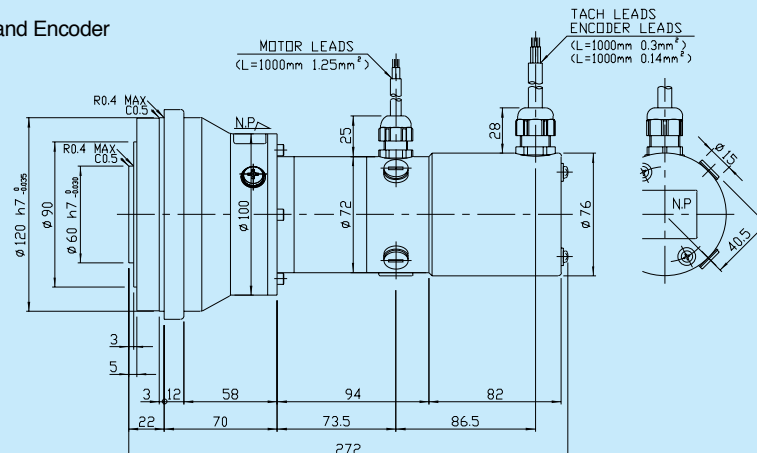
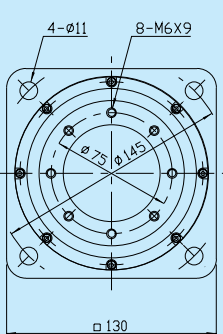

RFS-25-XX18 Actuator Only

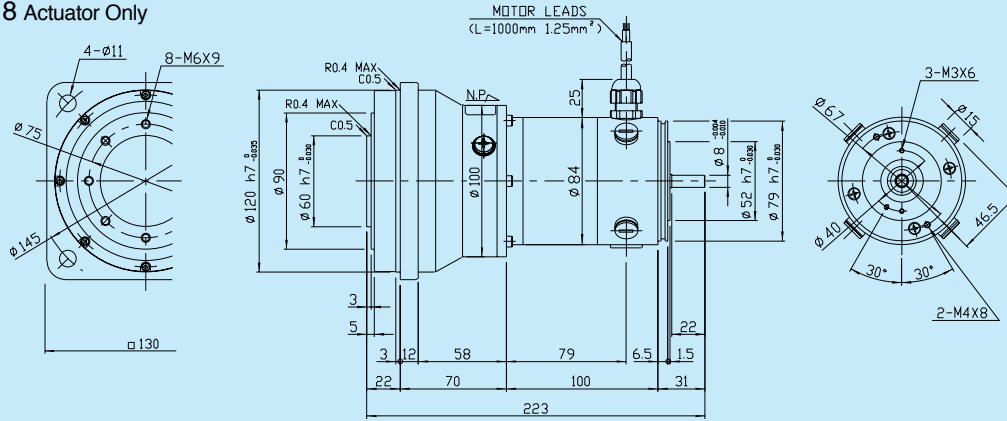

RFS-25-XX18-T With Tach-Generator

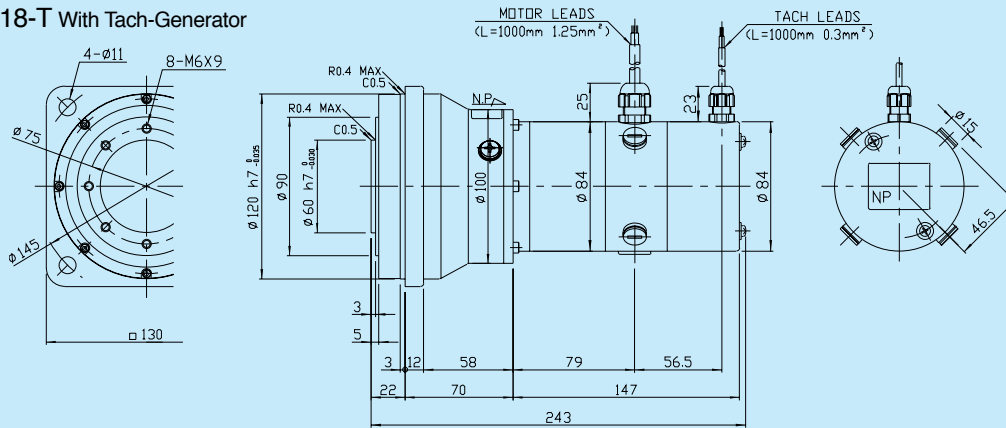

RFS-25-XX18-E With Encoder

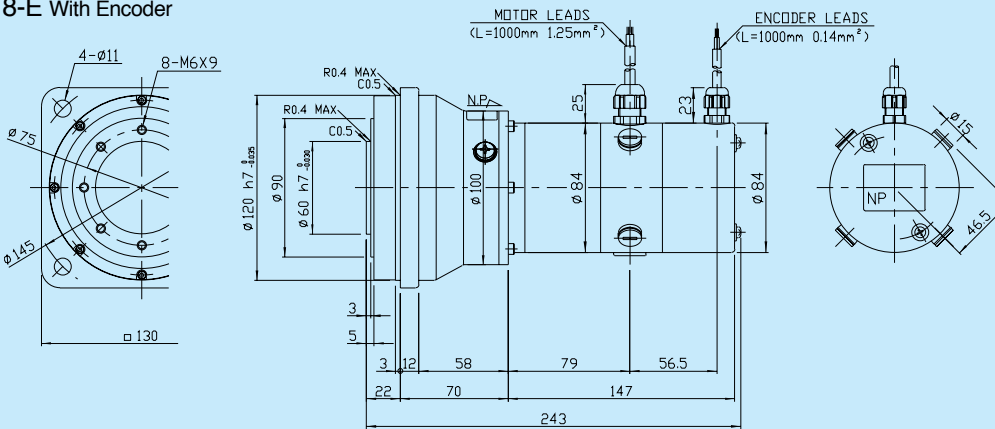

RFS-25-XX18-TE With Tach-Generator and Encoder

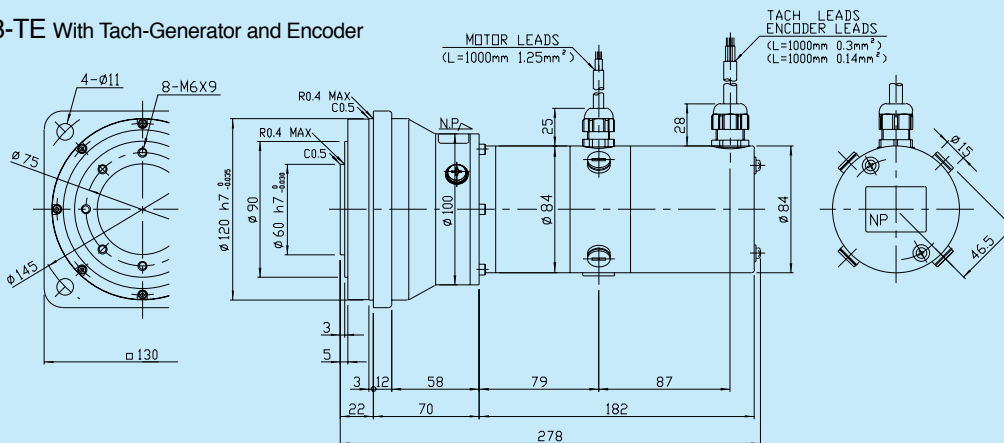

Outline and Dimensions

mm

RFS-32-XX18 Actuator Only

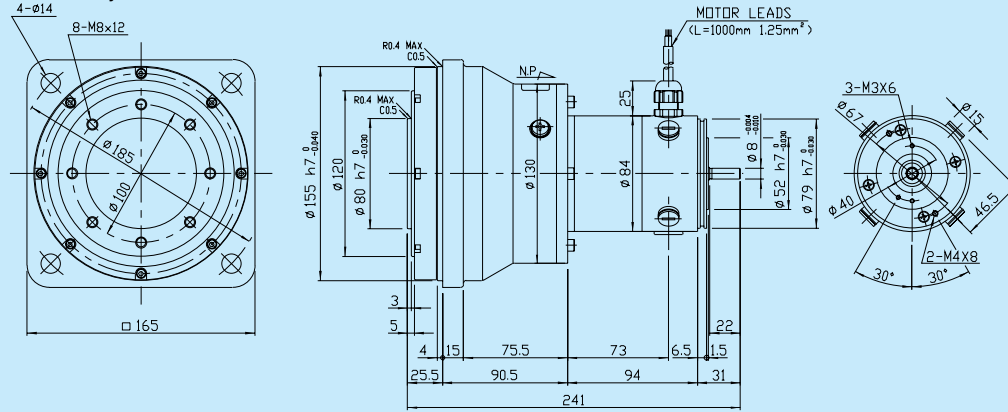

RFS-32-XX18-T With Tach-Generator

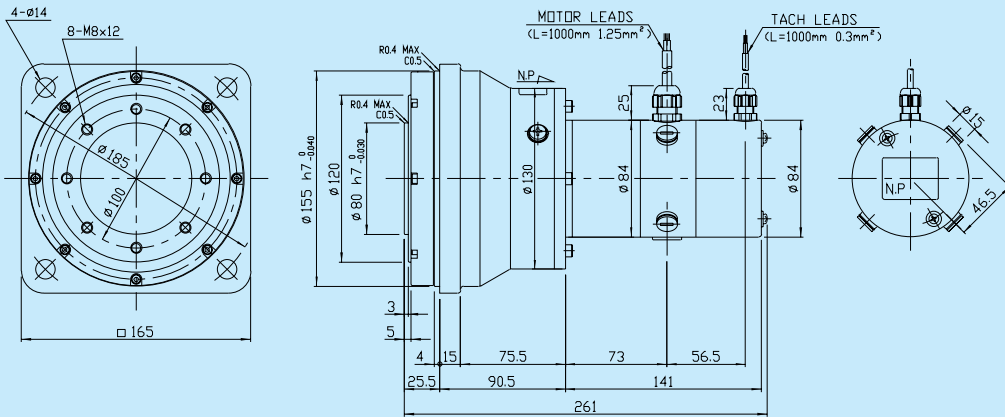

RFS-32-XX18-E With Encoder

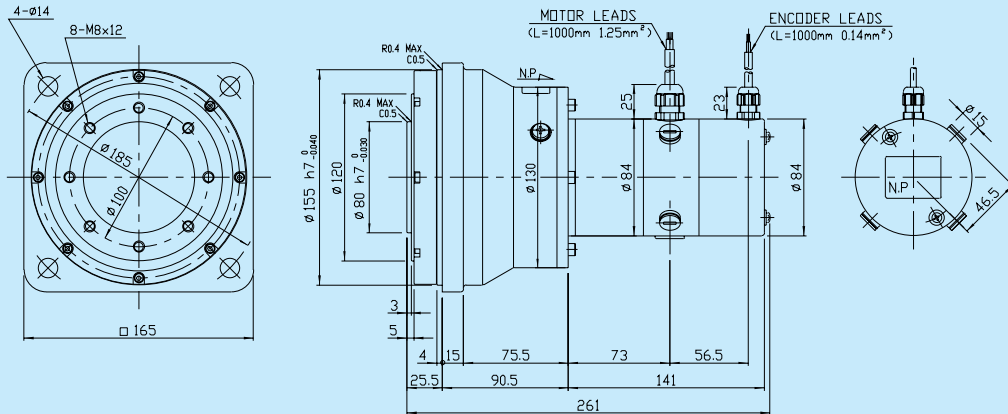

RFS-32-XX18-TE With Tach-Generator and Encoder

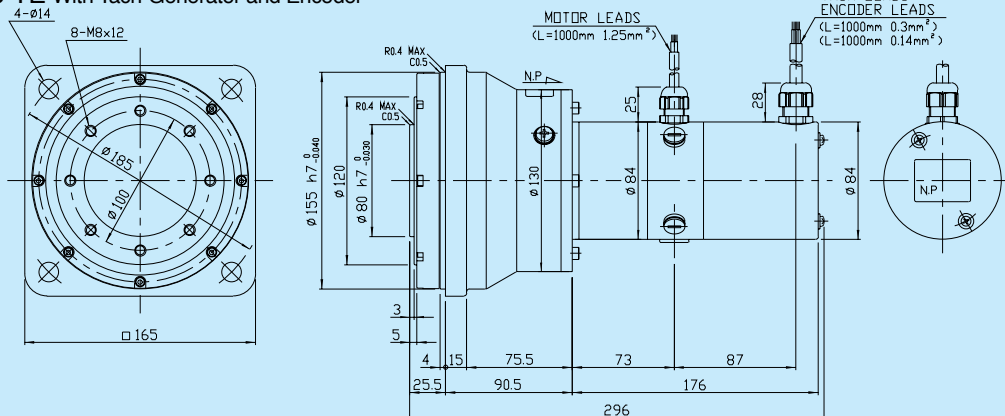

RFS-32-XX30 Actuator Only

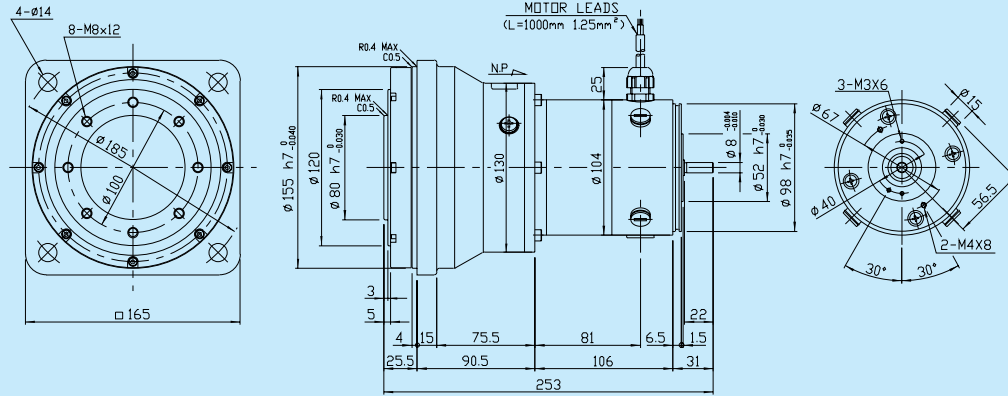

RFS-32-XX30-T With Tach-Generator

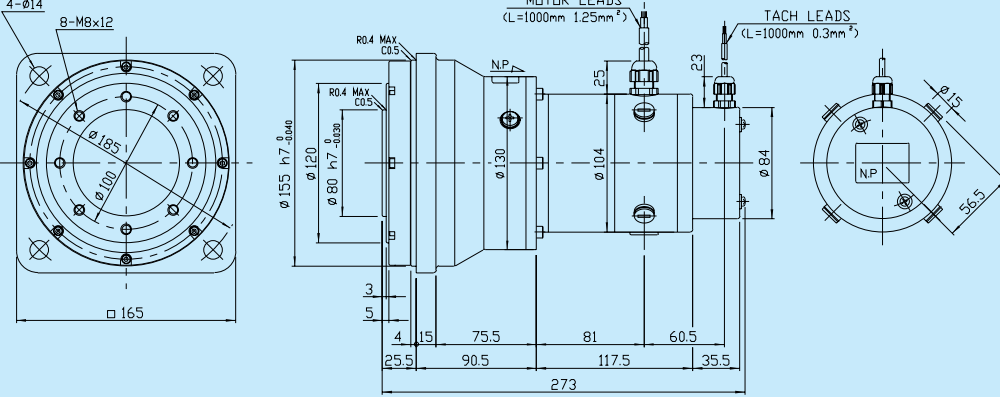

RFS-32-XX30-E With Encoder

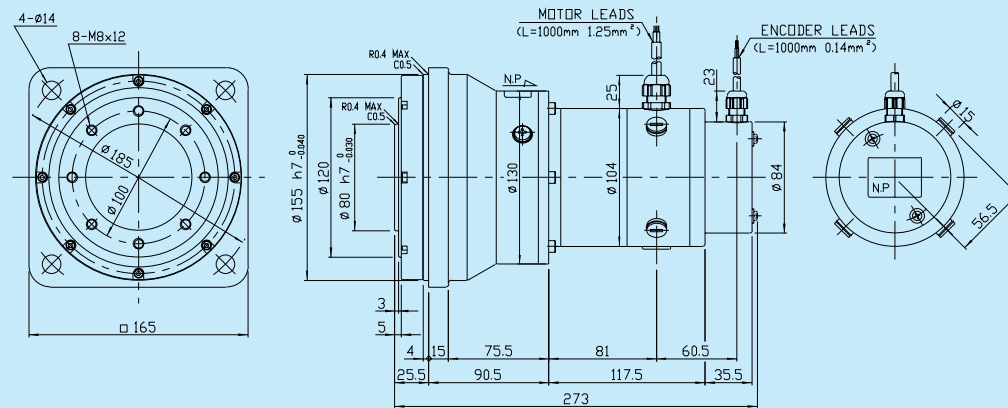

RFS-32-XX30-TE With Tach-Generator and Encoder

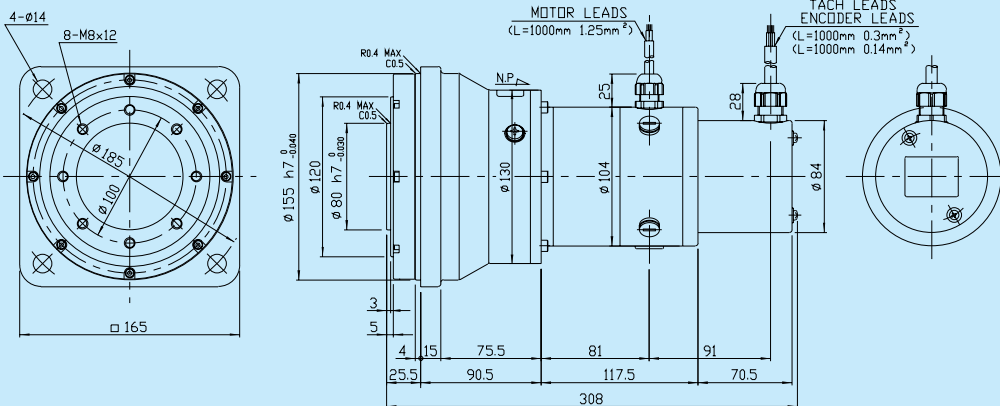

Ordering Codes

Servo Actuators

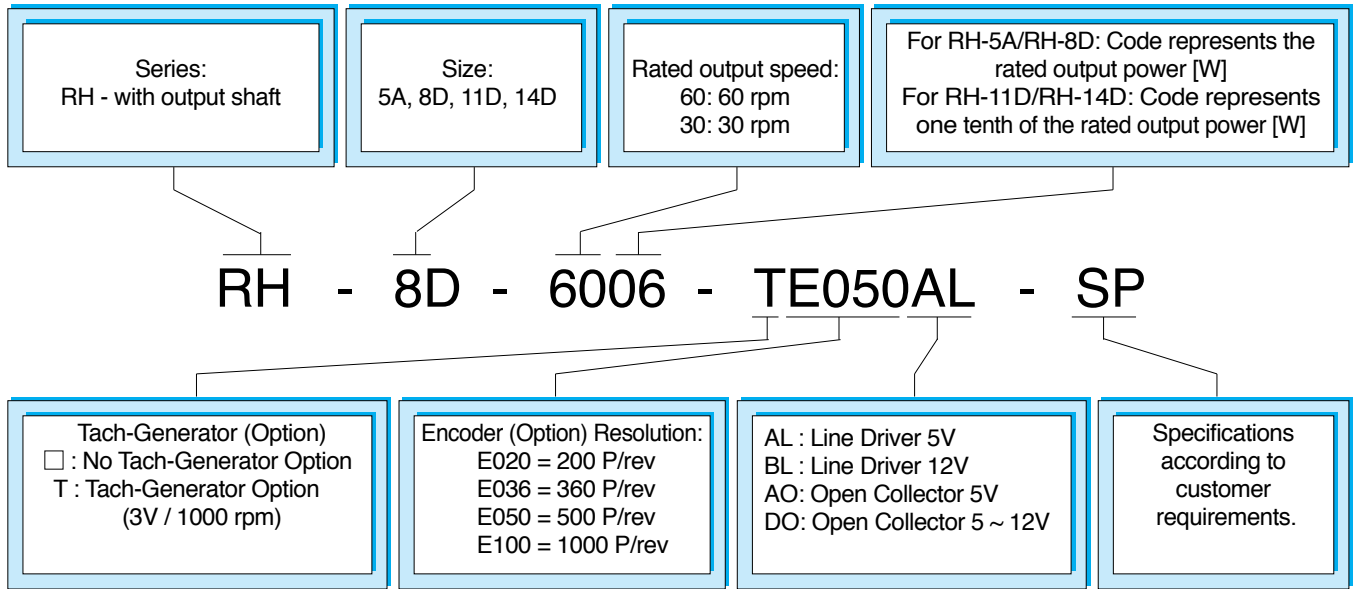

Servo Actuators

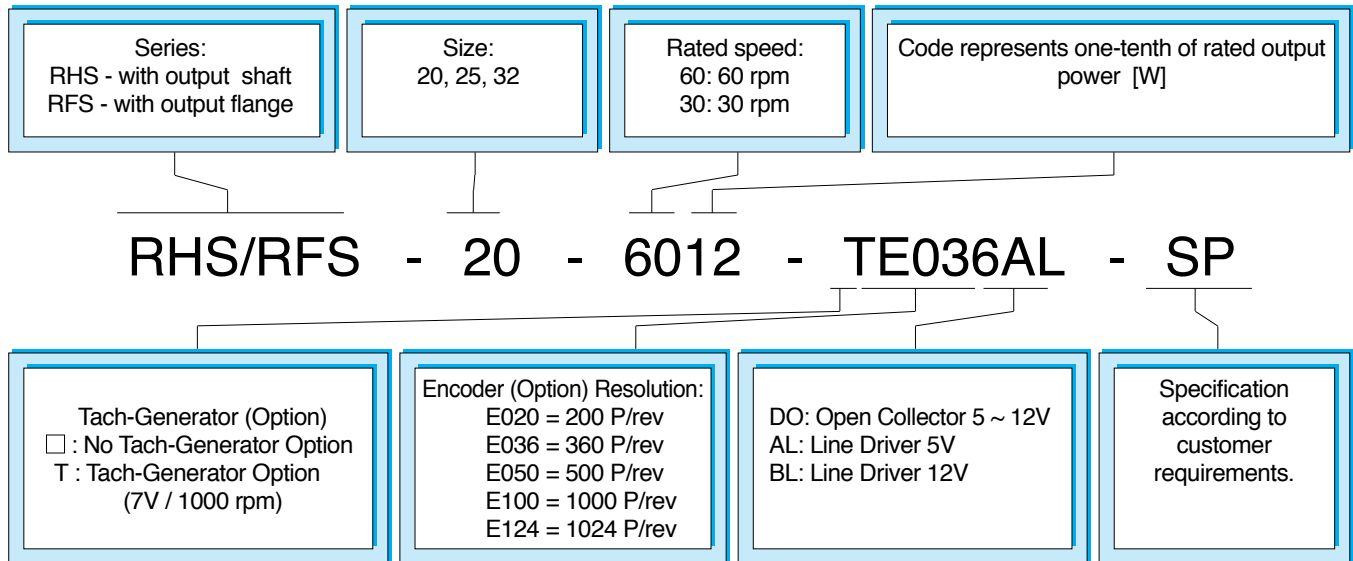

ALL PRODUCTS ARE WARRANTED TO BE FREE FROM DESIGN OR MANUFACTURING DEFECTS FOR A PERIOD OF ONE YEAR FROM THE DATE OF SHIPMENT. SUCH ITEMS WILL BE REPAIRED OR REPLACED AT THE DISCRETION OF HARMONIC DRIVE LLC.

THE SELLER MAKES NO WARRANTY, EXPRESSED OR IMPLIED, CONCERNING THE MATERIAL TO BE FURNISHED OTHER THAN IT SHALL BE OF THE QUALITY AND SPECIFICATIONS STATED. THE SELLER'S LIABILITY FOR ANY BREACH IS LIMITED TO THE PURCHASE PRICE OF THE PRODUCT.

ALL EFFORTS HAVE BEEN MADE TO ASSURE THAT THE INFORMATION IN THIS CATALOG IS COMPLETE AND ACCURATE. HOWEVER, HARMONIC DRIVE LLC IS NOT LIABLE FOR ANY ERRORS, OMMISIONS OR INACCURACIES IN THE REPORTED DATA. HARMONIC DRIVE LLC RESERVES THE RIGHT TO CHANGE THE PRODUCT SPECIFICATIONS, FOR ANY REASON, WITHOUT PRIOR NOTICE.



Harmonic Drive LLC

247 Lynnfield Street
Peabody, MA 01960

800-921-3332

F: 978-532-9406

www.HarmonicDrive.net

Worldwide Locations:

Harmonic Drive Systems, Inc.
Minamiohi 6-25-3, Shinagawa-ku
Tokyo 140, Japan

Harmonic Drive AG
Hoenbergstr, 14
Limburg/Lahn, D-65555 Germany