

RSF Mini Series

RSF Brushless Servo Actuator



Total Motion Control

harmonic drive actuator

Precision Gearing & Motion Control

1. Applicable Models

This Specification applies to the RSF-B mini Series with parallel encoder and supply voltage DC 24V.

The sizes available are:

- 1) RSF-8B-XXX-F100-24B
- 2) RSF-11B-XXX-F100-24B
- 3) RSF-14B-XXX-F100-24B

2. Model Ordering Code

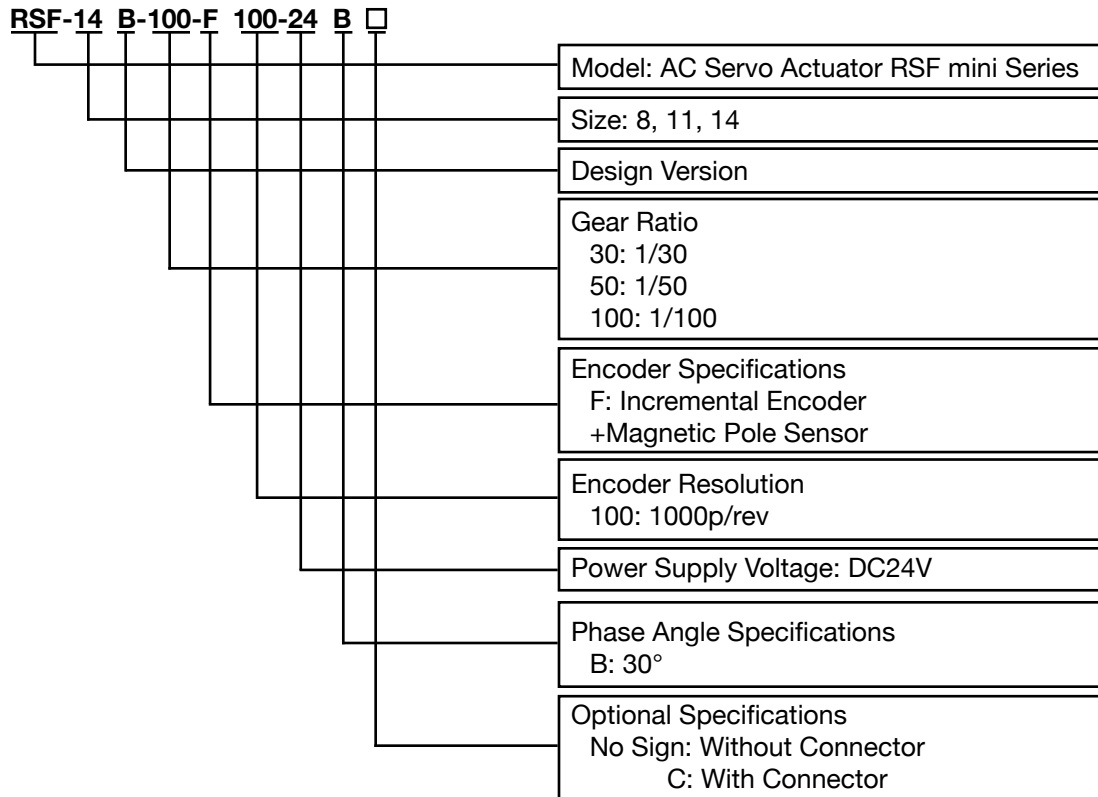

3. Specification

Refer the manual of RSF-B mini standard type except the following specifications.

3-1 Actuator

Table 1 General specifications of RSF-8B/11B/14B

Item	Environmental Conditions
Operate temperature	0~40 °C
Storage temperature	-20~60 °C
Operate / Storage humidity	20~80%RH (No condensation)
Vibration resistance	25 m/s ² (Frequency: 10~400 Hz)
Impact resistance	300 m/s ²

Table 2 Ability Specifications

Item		Model	RSF-8B			RSF-11B			RSF-14B		
			30	50	100	30	50	100	30	50	100
Power Supply Voltage	V	DC24									
Maximum Torque ※	Nm	1.8	3.3	4.8	4.5	8.3	11	9.0	18	28	
Maximum Speed ※	r/min	200	120	60	200	120	60	200	120	60	
Maximum Current ※	A	3.8	3.9	2.9	14.4	15.8	9.4	14.4	17.2	12.3	
Allowable Continuous Torque ※	Nm	0.78	1.4	2.0	1.1	2.0	4.0	1.7	3.0	6.0	
Allowable Continuous Current ※	A	2.0	2.0	1.5	5.0	4.9	4.9	4.9	4.7	4.7	
Allowable Continuous Speed ※	r/min	100	60	30	100	60	30	100	60	30	
Continuous torque at stall ※	Nm	0.95	1.7	3.5	1.7	3.0	5.7	2.5	4.5	9.0	
	Kgfc/m	9.2	16	36	17	31	58	26	46	92	
Torque Constant	Nm/A	0.62	1.1	2.1	0.40	0.66	1.5	0.76	1.3	2.6	
	Kgfc/m/A	6.3	11	21	4.1	6.7	15	7.8	13	27	
EMF Constant	V(r/min)	0.07	0.11	0.22	0.04	0.07	0.15	0.08	0.13	0.28	
Phase Resistance	Ω (25°C)	0.93			0.19			0.26			
Phase Inductance	mH	0.45			0.10			0.19			
Moment of Inertia ⁴⁾	GD ² /4 $\times 10^{-2}$ k·gm ²	0.06	0.16	0.65	0.18	0.49	2.0	0.41	1.1	4.5	
	J $\times 10^{-2}$ kgf·cm·s ²	0.60	1.7	6.6	1.8	5.0	20	4.1	11	46	
Allowable Radial Load	N	196			245			392			
	kgf	20			25			40			
Allowable Thrust Load	N	98			196			392			
	kgf	10			20			40			
Quad Encoder Resolution ⁵⁾	p/rev	120000	200000	400000	120000	200000	400000	120000	200000	400000	
Mass	kg	0.3			0.5			0.8			
Combination Driver		HA-680-4B-24			HA-680-6B-24						

- 1) The table shows output values of the actuator.
- 2) All specifications are applicable for actuators mounted on an aluminum heat sink of size: 150 x 150 x 6(mm)
- 3) Values for saturated actuator temperature. Other values are for actuator temperature of 20°C.
- 4) The moment of inertia is the total value of the motor shaft and Harmonic Drive moment of inertia values converted to the output side.
- 5) Quad encoder resolution is (motor shaft encoder resolution) x 4 x (gear ratio)

3-2 Encoder Specifications

Table 3 Magnetic pole sensor (build in the motor)

Item	Unit	Specification
Signal		U, \bar{U} , V, \bar{V} , W, \bar{W}
Power supply voltage	V	DC +5 ±5%
Current consumption	mA	250 max
Output circuit form		Line driver

Table 4 Encoder

Item	Unit	Specification
Type		Incremental, rectangular wave, 8-wires
Signal		A, \bar{A} , B, \bar{B} , Z, \bar{Z}
Resolution	p/rev	1000
Power supply voltage	V	DC +5 ±5%
Current consumption	mA	170 max
Output circuit form		Line driver

• Singal waveform

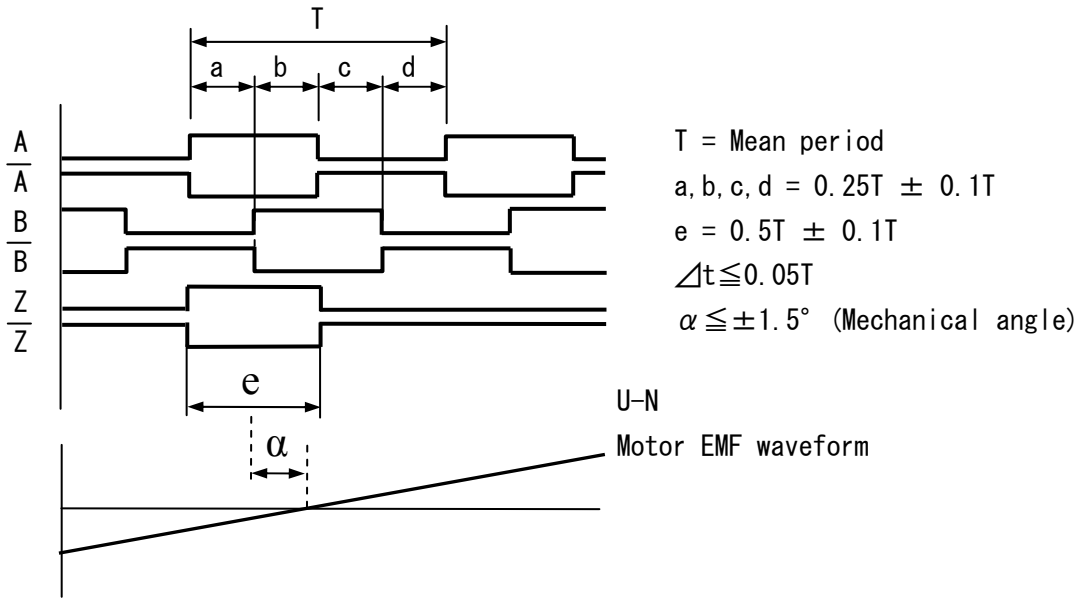

Fig.1 A, B and Z signal and relationship with U-N motor EMF waveform with CW rotation facing the output shaft end

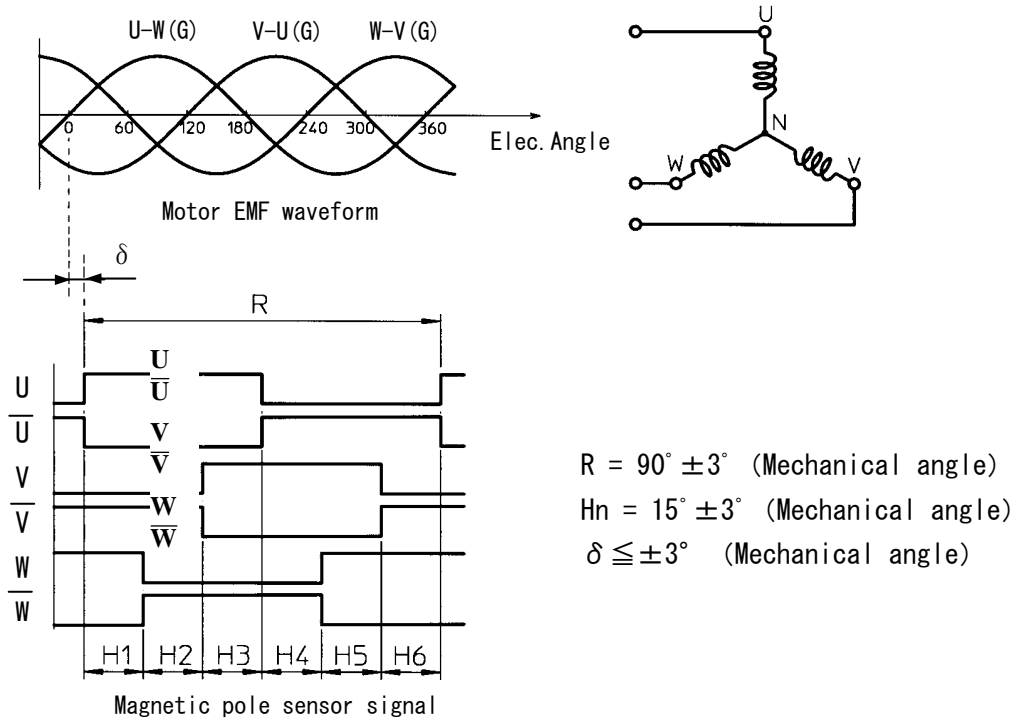

Fig.2 U, V and W signal and relationship with Motor's EMF with CW rotation facing the output shaft end

- **Color code for leads**

Color code for motor, encoder and magnetic pole sensor leads shown in Table 5

Table 5 Color code

Motor leads		Hall sensor leads		Encoder leads	
Color	Signal	Color	Signal	Color	Signal
Red	U	Brown	U	Brown	A
White	V	Blue	\bar{U}	Blue	\bar{A}
Black	W	Red	V	Red	B
		Green	\bar{V}	Green	\bar{B}
		Yellow	W	Yellow	Z
		Orange	\bar{W}	Orange	\bar{Z}
		White	+5V (Vcc)	White	+5V (Vcc)
		Black	0V (GND)	Black	0V (GND)
				Shield	Floating

- **Output circuit and example for receiving signal**

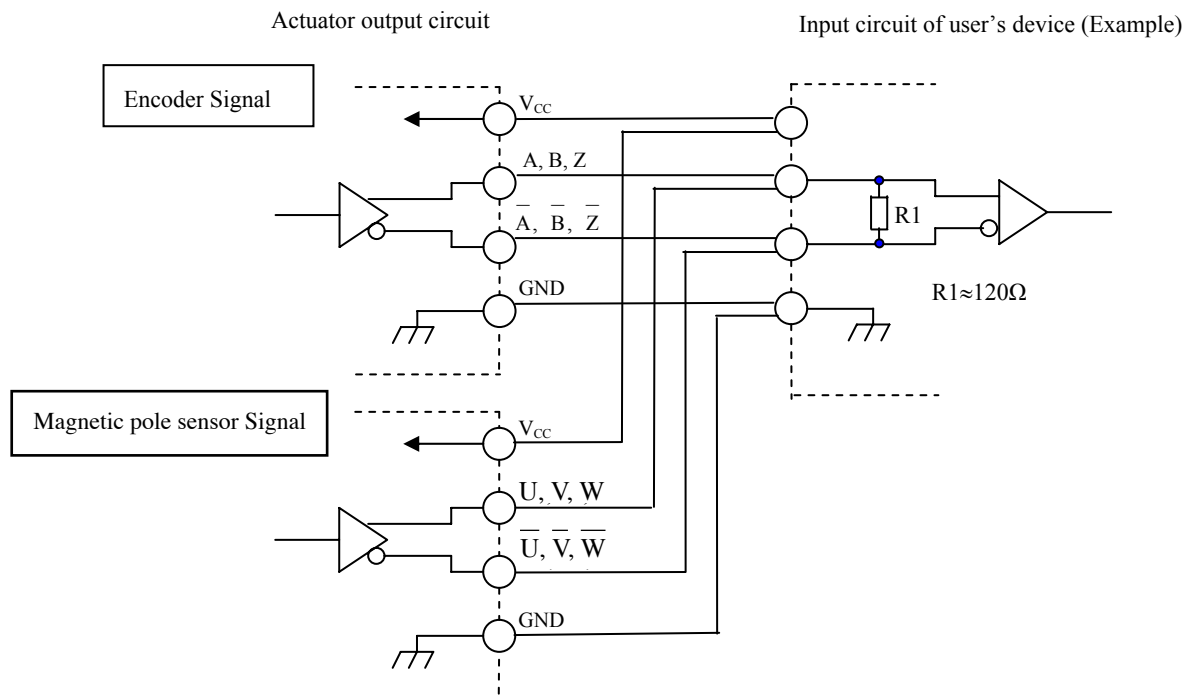

4. External Dimensions

RSF-8B-XXX-F100-24B

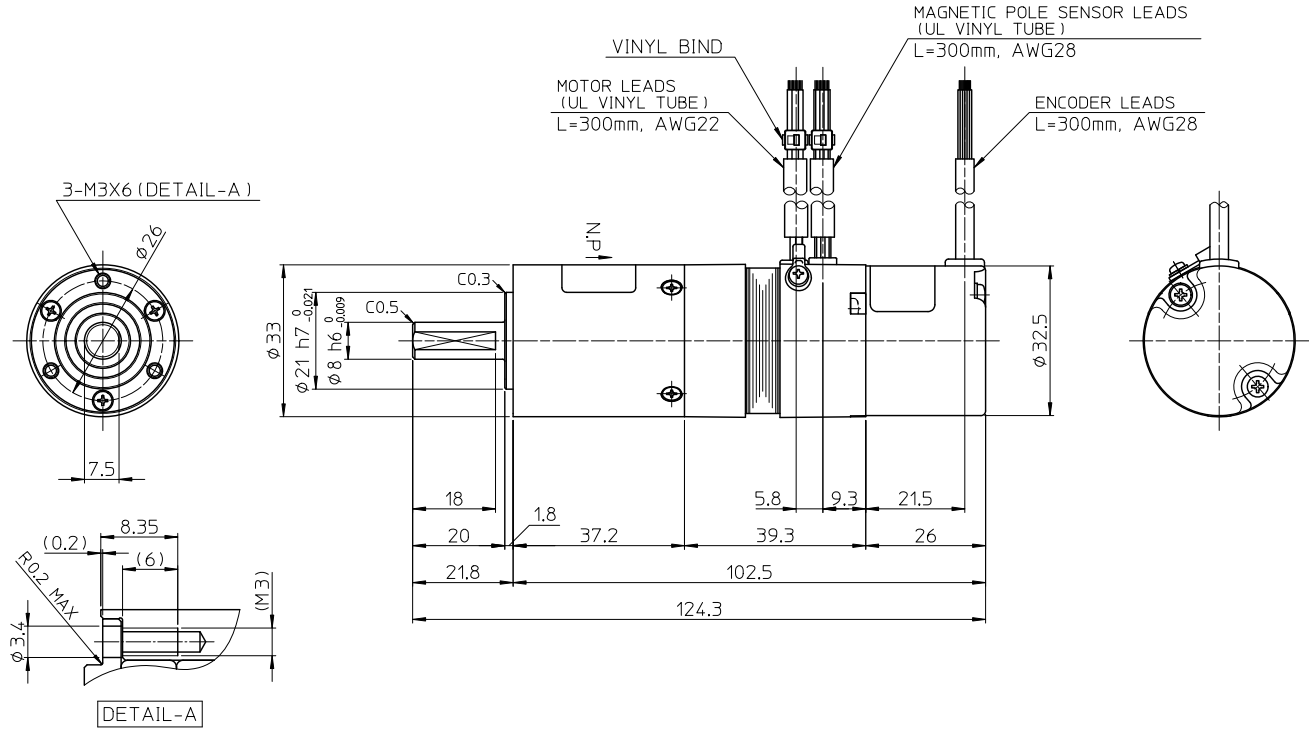

RSF-11B-XXX-F100-24B

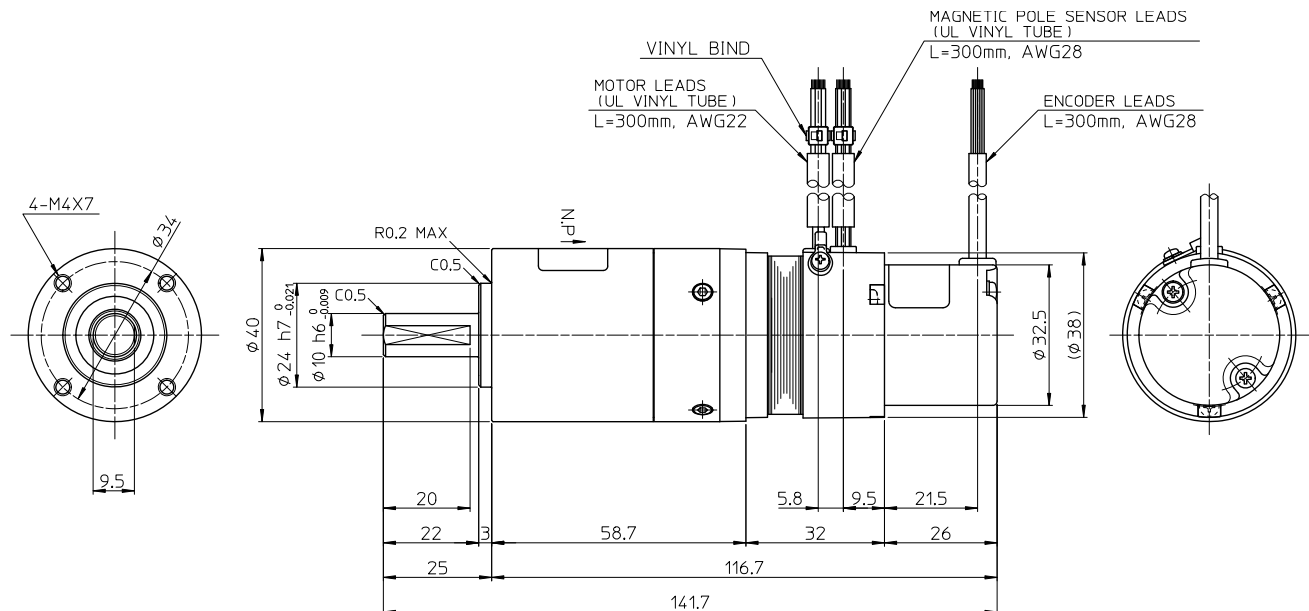

RSF-14B-XXX-F100-24B

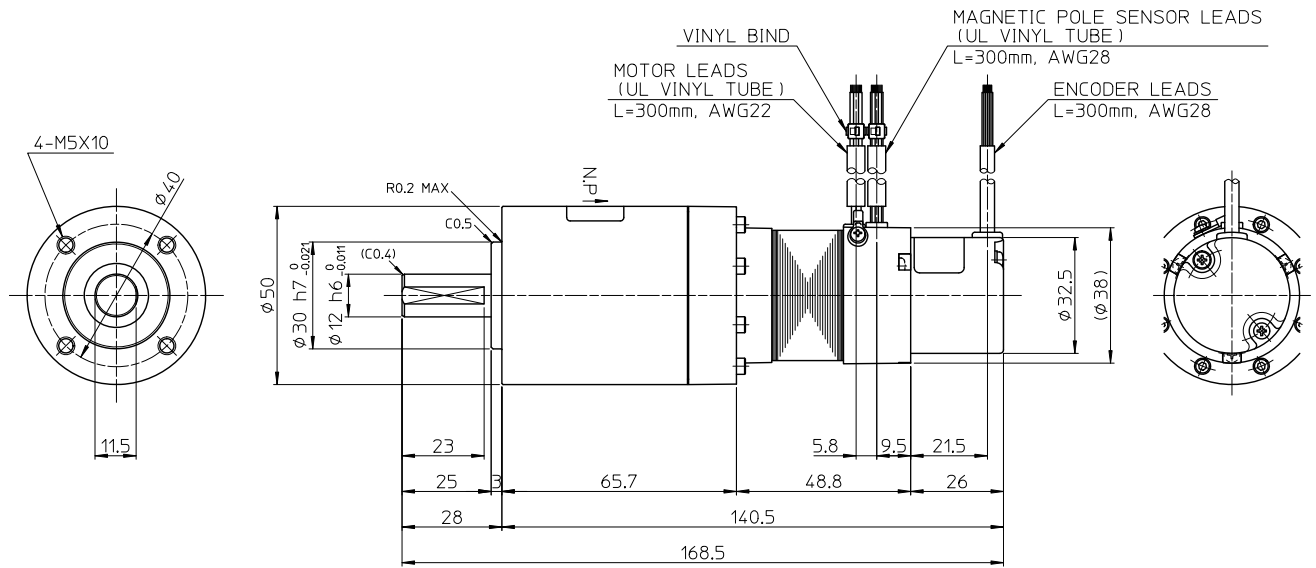

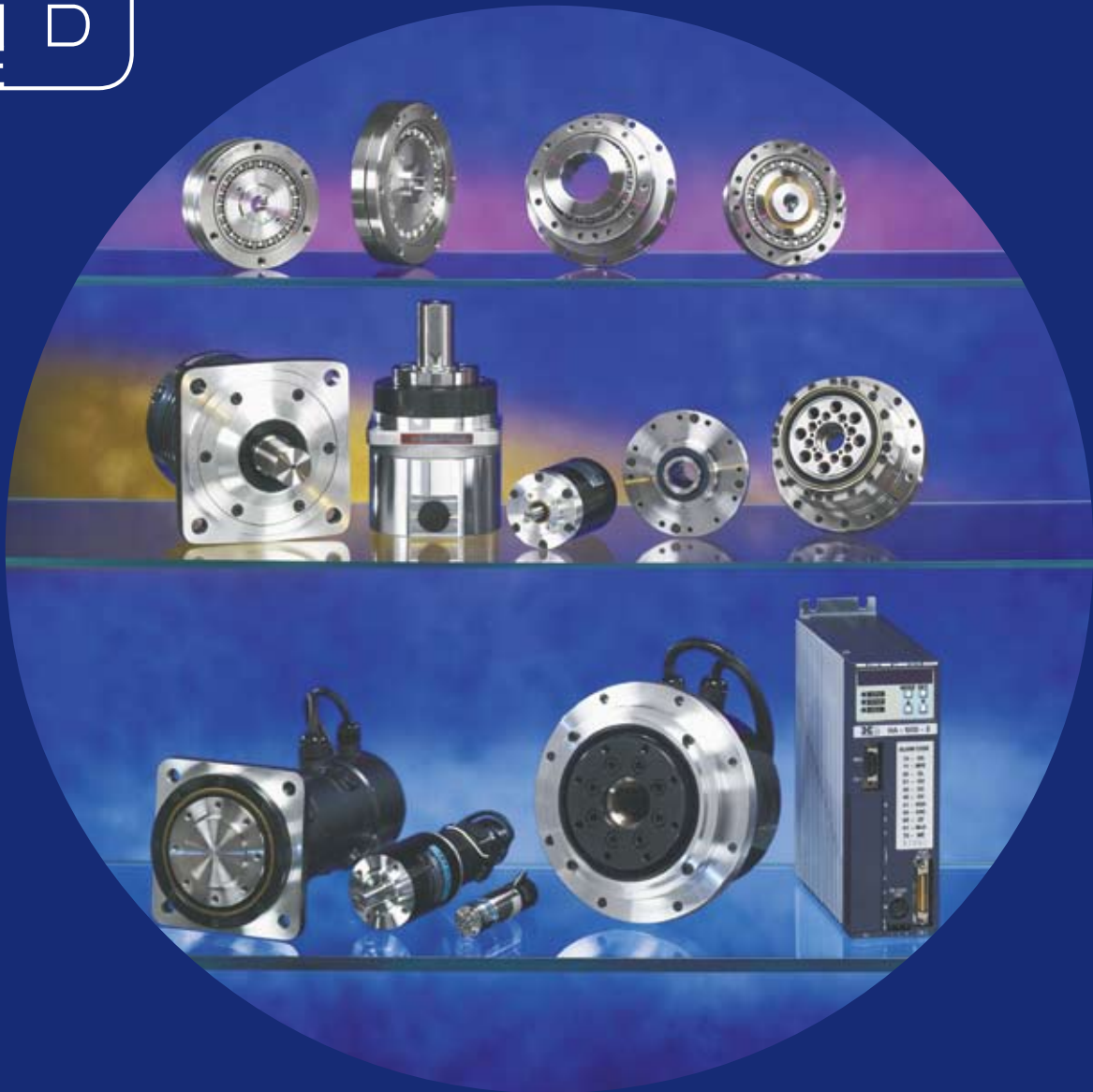

Harmonic Drive LLC

247 Lynnfield Street
Peabody, MA 01960

800-921-3332

F: 978-532-9406

www.HarmonicDrive.net

Harmonic Drive Systems, Inc.
Minamiohi 6-25-3, Shinagawa-ku
Tokyo 140, Japan

Harmonic Drive AG
Hoenbergstr, 14
Limburg/Lahn, D-65555 Germany