

Harmonic Drive[®]

AC Servo Actuator

S H A s e r i e s m a n u a l

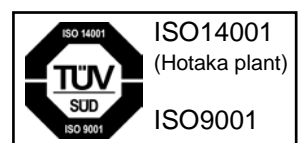
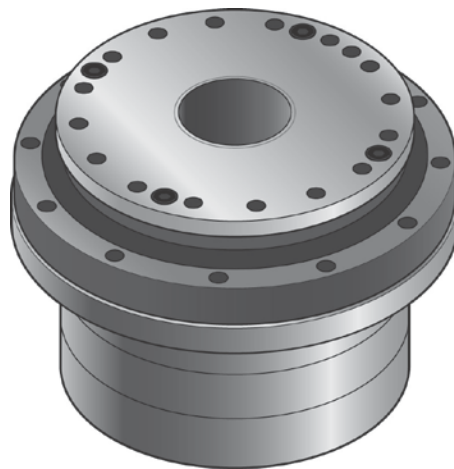

Introduction

Thank you for purchasing our SHA series AC Servo Actuator.



- Improper handling or use of this product may result in an accident or reduced life of the product. Read this document carefully and use the product correctly so that the product can be used safely for many years to come.
- Product specifications are subject to change without notice.
- Keep this manual in a convenient location and refer to it as necessary when operating or maintaining the actuator.
- The end user of the actuator should have a copy of this manual.

SAFETY GUIDE

To use this actuator safely and correctly, be sure to read SAFETY GUIDE and other parts of this manual carefully. It is important to fully understand the information provided herein before using the actuator.

NOTATION

Important safety information you must note is provided herein. Be sure to observe these instructions.

	Indicates a potentially hazardous situation, which, if not avoided, could result in death or serious personal injury.
	Indicates a potentially hazardous situation, which, if not avoided, may result in minor or moderate personal injury and/or damage to the equipment.
	Indicates what should be performed or avoided to prevent non-operation or malfunction of the product or negative effects on its performance or function.

LIMITATION OF APPLICATIONS

The equipment listed in this document may not be used for the applications listed below:

- Space equipment
- Automobile, automotive parts
- Aircraft, aeronautic equipment
- Amusement equipment, sport equipment, game machines
- Nuclear equipment
- Machine or devices acting directly on the human body
- Household apparatus
- Instruments or devices to transport or carry people
- Vacuum equipment
- Apparatus or devices used in special environments

If the above list includes your intending application for our products, please consult us.



Safety measures are essential to prevent accidents resulting in death, injury or damage of the equipment due to malfunction or faulty operation.

SAFETY NOTE

ITEMS YOU SHOULD NOTE WHEN USING THE ACTUATOR

• PRECAUTIONS FOR ACTUATORS AT THE APPLICATION DESIGN PHASE



Always use under followings conditions.

The actuator is designed to be used indoors. Observe the following conditions:

- Ambient temperature: 0°C to 40°C
- Ambient humidity: 20% to 80%RH (Non-condensation)
- Vibration: Max 25 m/s²
- No contamination by water, oil
- No corrosive or explosive gas

Follow the exact instructions in the related manuals to install the actuator in the equipment.

- Ensure precise alignment of the actuator shaft center and the corresponding center in the application.
- Failure to observe this caution may lead to vibration, resulting in damage of output elements.

• PRECAUTIONS FOR ACTUATORS IN OPERATION



Comply with the towque limits for the actuator.

- Be aware, that if by accident, the arm attached to the output element hits a solid object, the output element may become uncontrollable.

Never connect cables directly to a power supply socket.

- Each actuator must be operated with a proper driver.
- Failure to observe this caution may lead to injury, fire or damage of the actuator.

Do not apply impacts and shocks

- The actuator directly connects with the encoder so do not use a hammer during installation.
- Failure to observe this caution could damage the encoder and may cause uncontrollable operation.

Avoid handling of actuators by cables.

- Failure to observe this caution may damage the wiring, causing uncontrollable or faulty operation.

ITEMS YOU SHOULD NOTE WHEN USING THE DRIVER**● CAUTIONS RELATED TO THE DESIGN****Always use drivers under followings conditions.**

The driver generates heat. Use under the following conditions while paying careful attention to the heat radiation.

- Mount in a vertical position keeping sufficient clearance.
- 0°C to 50°C, 95%RH or below (No condensation)
- No vibration or physical shock
- No dust, dirt, corrosive or inflammable gas

Use sufficient noise suppressing means and safe grounding.

Any noise generated on a signal wire will cause vibration or improper motion. Conform to the following conditions.

- Keep signal and power leads separated.
- Keep leads as short as possible.
- Ground actuator and driver at one single point, minimum ground resistance class: D (less than 100 ohms)
- Do not use a power line filter in the motor circuit.

Pay attention to negative torque by inverse load.

- Inverse load may cause damages of drivers.
- Please consult our sales office, if you intent to apply products for inverse load.

Use a fast-response type ground-fault detector designed for PWM inverters.

Do not use a time-delay-type ground-fault detector.

Safety measures are essential to prevent accidents resulting in death, injury or damage of the equipment due to malfunction or faulty operation.

● CAUTIONS FOR USAGE**Never change wiring while power is active.**

Make sure of power non-active before servicing the products. Failure to observe this caution may result in electric shock or personal injury.

Do not touch terminals or inspect products at least 5 minutes after turning OFF power.

- Otherwise residual electric charges may result in electric shock.
- Make installation of products not easy to touch their inner electric components.



Do not make a voltage resistance test.

- Failure to observe this caution may result in damage of the control unit.
- Please consult our sales office, if you intent to use a voltage resistance test.

Do not operate control units by means of power ON/OFF switching.

- Start/stop operation should be performed via input signals.
- Failure to observe this caution may result in deterioration of electronic parts.

DISPOSAL



All products or parts have to be disposed of as industrial waste.

Since the case or the box of drivers have a material indication, classify parts and dispose them separately.

Contents

SAFETY GUIDE	1
NOTATION	1
LIMITATION OF APPLICATIONS.....	1
SAFETY NOTE	2
Contents	5

Chapter 1 Outlines

1-1 Overview	1-1
1-2 Model	1-2
1-3 Drivers and extension cables	1-3
1-4 Specifications	1-4
1-5 Brake	1-16
1-6 External dimensions.....	1-19
1-7 Mechanical accuracy	1-31
1-8 One way positional accuracy	1-33
1-9 Detector specifications (Absolute encoder).....	1-35
1-10 Rigidity	1-37
Moment stiffness	1-37
Torsional stiffness (HarmonicDrive® speed reducer with ratio greater than 51) ..	1-38
Torsional stiffness (Hollow planetary HPF series with reduction ratio 11)	1-40
1-11 Direction of rotation.....	1-41
1-12 Shock resistance.....	1-42
1-13 Vibration resistance	1-43
1-14 Operable range	1-44
1-15 Cable specifications	1-59
Motor cable specifications	1-59
Encoder cable specifications	1-60

Chapter 2 Selection guidelines

2-1	SHA series selection	2-1
	Allowable load moment of inertia	2-1
2-2	Change in load moment of inertia	2-6
2-3	Verifying and examining load weights	2-7
	Maximum load moment load.....	2-8
	Verifying life.....	2-8
	Verifying static safety coefficients	2-10
2-4	Examining the operating conditions	2-11
	Calculate the actuator rotation speed	2-11
	Calculating and examining load moment of inertia.....	2-11
	Load torque calculation	2-12
	Acceleration time and deceleration time	2-13
	Examining effective torque and average rotation speed.....	2-14

Chapter 3 Installing the SHA actuator

3-1	Receiving Inspection.....	3-1
	Inspection procedure	3-1
3-2	Notices on handling	3-2
	Installation and transmission torque	3-2
	Precautions on installation.....	3-4
	Use of positioning pins	3-5
	Surface treatments	3-5
3-3	Location and installation	3-6
	Environment of location	Error! Bookmark not defined.
	Installation	3-7

Chapter 4 Options

4-1	Options.....	4-1
	With near origin and end limit sensors (option code: L)	4-1
	Cable taken out from side face (option code: Y)	4-1
	Extension cables	4-2

Chapter 5 Appendix

5-1	Unit conversion	5-1
5-2	Calculating inertia moment	5-3
	Formula of mass and inertia moment	5-3
	Inertia moment of cylinder	5-5

Overview of the SHA series

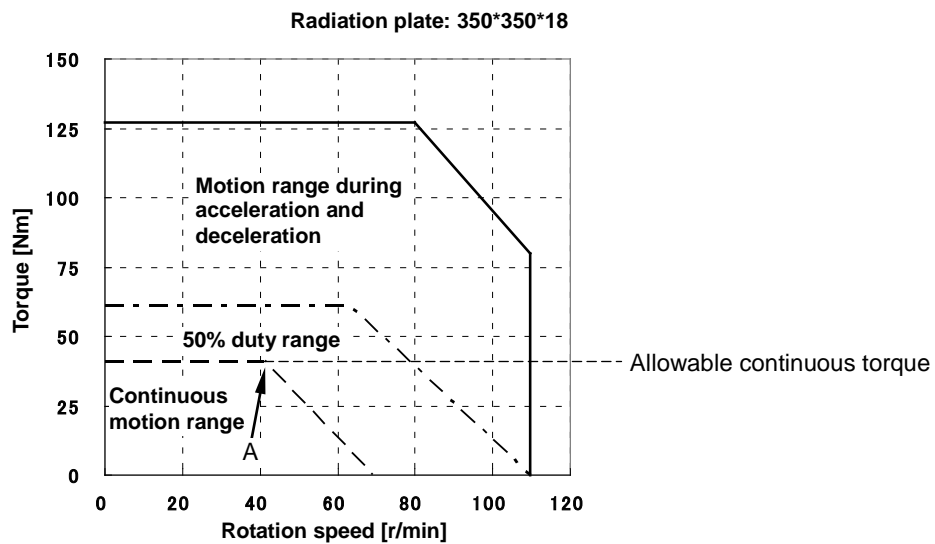

The nameplate values of various models are shown below.

SG/HP type

Item	Model	SHA20A				
		51	81	101	121	161
(1) Output at point A	W	99	109	109	106	86
(2) Voltage at point A	V	113	117	117	119	122
(3) Allowable continuous current	A	2.1	2.0	2.0	1.9	1.6
(4) Speed at point A	rpm	44	30	24	21	17
(5) Frequency at point A	Hz	187	203	202	212	228
(6) Allowable range temperature	°C	40				
(7) Number of phase	—	3				

Item	Model	SHA25A (Motor input voltage 100V)					SHA25A (Motor input voltage 200V)					
		51	81	101	121	161	11	51	81	101	121	161
(1) Output at point A	W	165	188	190	178	127	133	175	203	207	178	127
(2) Voltage at point A	V	61	64	65	64	62	101	115	122	125	125	120
(3) Allowable continuous current	A	4.7	4.7	4.7	4.5	3.7	3.0	3.0	3.0	2.9	2.6	2.1
(4) Speed at point A	rpm	45	31	25	21	15	141	41	29	24.5	21	15
(5) Frequency at point A	Hz	191	209	210	212	201	129	174	196	206	212	201
(6) Allowable range temperature	°C	40										
(7) Number of phase	—	3										

Item	Model	SHA32A						SHA40A				
		11	51	81	101	121	161	51	81	101	121	161
(1) Output at point A	W	240	328	369	373	308	233	487	564	570	560	480
(2) Voltage at point A	V	97	110	114	118	116	115	109	115	115	116	122
(3) Allowable continuous current	A	6.0	6.0	6.0	5.7	5.0	4.1	9.0	9.0	9.0	8.8	7.2
(4) Speed at point A	rpm	115	34	23	20	16.5	12.5	29	20.5	16.5	14	12
(5) Frequency at point A	Hz	105	145	155	168	166	168	123	138	139	141	161
(6) Allowable range temperature	°C	40										
(7) Number of phase	—	3										

Item	Model	SHA58A				SHA65A			
		81	101	121	161	81	101	121	161
(1) Output at point A	W	897	948	863	731	964	963	958	802
(2) Voltage at point A	V	99	101	101	107	92	92	96	100
(3) Allowable continuous current	A	17.7	17.8	16.4	13.4	22.0	21.9	20.1	16.3
(4) Speed at point A	rpm	12	10	8.5	7.2	10	8	7.4	6.2
(5) Frequency at point A	Hz	130	135	137	155	108	108	119	133
(6) Allowable range temperature	°C	40							
(7) Number of phase	—	3							

CG type

Item	Model	SHA20A				
		50	80	100	120	160
(1) Output at point A	W	97	108	108	106	85
(2) Voltage at point A	V	112	116	116	119	122
(3) Allowable continuous current	A	2.1	2.1	2.1	2.0	1.7
(4) Speed at point A	rpm	44	29.5	24	21	17
(5) Frequency at point A	Hz	183	197	200	210	227
(6) Allowable range temperature	°C	40				
(7) Number of phase	—	3				

Item	Model	SHA25A(Motor input voltage 100V)					SHA25A ((Motor input voltage 200V)				
		50	80	100	120	160	50	80	100	120	160
(1) Output at point A	W	167	191	192	174	127	177	201	204	174	127
(2) Voltage at point A	V	62	65	65	63	61	115	121	123	123	119
(3) Allowable continuous current	A	4.7	4.7	4.7	4.5	3.7	3.0	3.0	3.0	2.6	2.1
(4) Speed at point A	rpm	47	32	25.5	20.5	15	42	29	24	20.5	15
(5) Frequency at point A	Hz	196	213	213	205	200	175	193	200	205	200
(6) Allowable range temperature	°C	40									
(7) Number of phase	—	3									

Item	Model	SHA32A					SHA40A				
		50	80	100	120	160	50	80	100	120	160
(1) Output at point A	W	321	372	373	308	233	493	558	568	568	488
(2) Voltage at point A	V	109	114	117	116	115	109	114	115	116	123
(3) Allowable continuous current	A	6.0	6.0	5.7	5.0	4.1	9.0	9.0	9.0	8.8	7.2
(4) Speed at point A	rpm	34	23.5	20	16.5	12.5	30	20.5	16.6	14.2	12.2
(5) Frequency at point A	Hz	142	157	167	165	167	125	137	138	142	163
(6) Allowable range temperature	°C	40									
(7) Number of phase	—	3									

Chapter 1

Overview

This chapter explains the features, functions and specifications of the actuator.

1-1 Overview.....	1-1
1-2 Model.....	1-2
1-3 Combinations with drivers and extension cables	1-3
1-4 Specifications.....	1-4
1-5 Motor shaft holding brake	1-16
1-6 External dimensions	1-19
1-7 Mechanical accuracy	1-31
1-8 One Way positional accuracy.....	1-33
1-9 Detector specifications (Absolute encoder)	1-35
1-10 Rigidity.....	1-37
1-11 Rotation direction	1-41
1-12 Shock resistance.....	1-42
1-13 Resistance to vibration.....	1-43
1-14 Operable range	1-44
1-15 Cable specifications	1-59

1-1 Overview

The SHA series of AC Servo Actuators provide high torque and high accuracy rotary motion. These AC Servo Actuators are each composed of a Harmonic Drive® speed reducer for precise control and a flat, high performance AC servo motor with an integral absolute multi-turn encoder. The SHA series AC Servo Actuators all feature a large hollow shaft through the axis of rotation.

There are 3 types of speed reducers: SG with SHG series incorporated, HP with HPF series incorporated, and CG with the newly added CSG series incorporated. They are an advanced version of current FHA series AC Servo Actuators having a flat, hollow structure.

One key feature of the SHA actuators is their compact size. The outside diameter has been minimized, providing a maximum torque/volume ratio which is approximately double that of conventional FHA actuators. A through hole is provided in the center of the actuator, through which wiring, air lines, laser beams or concentric shafts may be passed.

The HA-800 series driver is a dedicated family of servo drive units for position/speed control, developed exclusively for driving SHA series actuators. The small, multi-functional drivers control the SHA series actuators' operations with great accuracy and precision. Additionally, the REL driver series may be used, which provides interface to many network field buses.

◆ Improved Torque Density

High-torque SHG series Harmonic Drive® speed reducers are incorporated into the actuator for precise control and the outer diameter of the actuator has been reduced by 20% compared to our FHA series. As a result, the maximum torque/volume ratio has approximately doubled compared to our previous actuator designs. Based on maximum torque, you can select a model which is one size smaller. Also, the output torque is approximately 10 times higher than direct drive motors of similar volume/weight. This is another reason why the SHA series has an outstanding performance advantage.

◆ Expanded product lineup

6 models are available for SG, accommodating high torque up to 3,400 Nm. The SHA line also includes models with reduction ratios of 51 to 161. CG series has 4 frame sizes available with 5 reduction ratios of 50:1 to 160:1.

◆ Modular design

The components of the SHA series, such as speed reducers, output shaft bearing, motor, brake and encoder, are arranged based on a modular design. We can also custom-design a model to meet your specific requirements. Please contact your HDLLC sales representative for details.

◆ Standard 17-bit magnetic absolute encoder

The newly developed AC servo motors are equipped with our original, highly reliable 17-bit magnetic* absolute encoder with safety functions. The serial communication reduces wiring and provides not only a multi-turn encoder, which is a must-have feature on actuators with speed reducers, but it also has an internal backup battery to retain absolute positions even when the encoder cable is disconnected for short periods of time.

The encoder circuitry also constantly compares two separate sets of encoder signals. If any abnormality is detected, the encoder's built-in failsafe function outputs an alarm signal to the host system.

*SHA 20 comes with an optical encoder.

◆ Support for network controls

By using a dedicated HA-800 series driver, you can control your actuator on a MECHATROLINK-II or CC-Link network. The REL series drivers support EtherCat, CanOpen, and DeviceNet.

◆ For high speeds

Also supports high speeds in combination with the hollow planetary speed reducer HPF series.

1-2 Model

Model numbers for the SHA series actuators and how to interpret them are explained below.

Examples of standard models:

SHA	32	A	101	SG	-	B	12	A	200	-	10	S17b	A	-	C			
(1)	(2)	(3)	(4)	(5)	-	(6)	(7)	(8)	(9)	-	(10)	(11)	(12)	-	(13)	(14)	-	(15)

(1) Model: SHA series actuator

(2) Size: 20, 25, 32, 40, 58, 65 : SG
25, 32 : HP
20, 25, 32, 40 : CG

(3) Version

(4) Reduction ratio (R:1)

Reduction ratio 11 is for the HPF hollow planetary speed reducer (Size 25, 32)

Reduction ratios 50 and higher are for the HarmonicDrive® gears

HPF		SHG		CSG	
11	11:1	51	51:1	50	50:1
		81	81:1	80	80:1
		101	101:1	100	100:1
		121	121:1	120	120:1
		161	161:1	160	160:1

(5) Gearhead

HP	HPF hollow shaft planetary
SG	HarmonicDrive® SHG series
CG	HarmonicDrive® CSG series

(6) Motor version symbol

A	Size: 58, 65
B	Size: 25, 32, 40
C	Size: 20

(7) Motor size

08	Size: 20
09	Size: 25
12	Size: 32
15	Size: 40
21	Size: 58, 65

(8) Brake

A	Without brake
B	With brake

(9) Motor input voltage

100	100V
200	200V

(100V is compatible with size 25 only)

(10) Encoder format

10	Conforming to A format, transmission rate: 2.5 Mbps, 1-on-1 connection
----	--

(11) Encoder type, resolution

S17b	17-bit absolute encoder, 131,072 pulses/revolution
11	D250: Incremental encoder (size 25, 32, and 40) Biss-C: Absolute encoder (size 25)

(12) Encoder phase angle: Phase difference between induced voltage in motor phase U and absolute origin

A	0 degree
---	----------

(13) Connector specification

C	With standard connector (for extension cables)
N	Without connector

(14) Option symbol

L	With near origin and end limit sensors
Y	Side exiting cable
S	Output shaft single revolution absolute model (CG type only)

(Please contact us for option-compatible models.)

(15) Special specification

Blank	Standard product
SP	Special specification product

1-3 Drivers and extension cables

The proper combination of SHA actuators, drivers, and extension cables are as follows:

		SHA20A	SHA25A	SHA32A	SHA40A	SHA58A	SHA65A
REL Servo Drive		REL-230-18	REL-230-18	REL230-36 REL 230-40			
HA-800 Standard I/O command type		HA-800A-3D/E -200	HA-800A-3D/E-200 (HA-800A-6D/E -100)	HA-800A-6D/E -200	HA-800A-6 D/E -200 or HA-800A-24D/E -200	HA-800A-24D/E -200	HA-800A-24D/E -200
HA-800 MECHATROLINK		HA-800B-3D/E -200	HA-800B-3D/E -200 (HA-800B-6D/E -100)	HA-800B-6D/E -200	HA-800B-6D/E -200 or HA-800B-24D/E -200	HA-800B-24D/E -200	HA-800B-24D/E -200
HA-800 CC-Link		HA-800C-3D/E -200	HA-800C-3D/E -200 (HA-800C-6D/E -100)	HA-800C-6D/E -200	HA-800C-6D/E -200 or HA-800C-24D/E -200	HA-800C-24D/E -200	HA-800C-24D/E -200
Extension cables (option)	Motor cable	EWD-MB**-A06-TN3 (Driver side connector supplied separately)			HA-800□-6D/E : EWD-MB**-A06-TN3 HA-800□-24D/E : EWD-MB**-A06-TMC	EWD-MB**-D09-TMC	
	Encoder cable	EWD-S**-A08-3M14				EWD-S**-D10-3M14	

** in the extension cable model indicates the cable length: 03 = 3m, 05 = 5m, 10 = 10m

The models shown in parenthesis are those with 100V motor input voltage combinations.

1-4 Specifications

SG type

Item		Model	SHA20A				
			51	81	101	121	161
Servo Drive		REL-230-18 HA-800□-3D/E-200					
Max. torque ^{*1}	Nm	73	96	107	113	120	
	kgf·m	7.4	9.8	10.9	11.5	12.2	
Allowable continuous torque ^{*1,2}	Nm	21	35	43	48	48	
	kgf·m	2.1	3.6	4.4	4.9	4.9	
Max. rotational speed ^{*1}	rpm	117.6	74.1	59.4	49.6	37.3	
Torque constant ^{*1}	Nm/A	16.5	27	33	40	53	
	kgf·m/A	1.7	2.7	3.4	4.1	5.4	
Max. current ^{*1}	A	6.0	4.9	4.5	4.0	3.4	
Allowable continuous current ^{*1,2}	A	2.1	2.0	2.0	1.9	1.6	
MEF constant ^{*3}	V/(rpm)	1.9	3.0	3.7	4.5	5.9	
Phase resistance (20°C)	Ω	1.4					
Phase inductance	mH	2.5					
Inertia moment (without brake)	GD ² /4	kg·m ²	0.23	0.58	0.91	1.3	2.3
	J	kgf·cm·s ²	2.4	6.0	9.3	13	24
Inertia moment (with brake)	GD ² /4	kg·m ²	0.26	0.65	1.0	1.4	2.6
	J	kgf·cm·s ²	2.6	6.6	10	15	26
Reduction ratio		51:1	81:1	101:1	121:1	161:1	
Permissible moment load	Nm	187					
	kgf·m	19.1					
Moment stiffness	Nm/rad	25.2 × 10 ⁴					
	kgf·m/arc min	7.5					
One-way positional accuracy	Sec.	60	50	50	50	50	
Encoder type		Absolute encoder					
Single motor revolution Encoder resolution		2 ¹⁷ (131,072)					
Motor multi revolution counter		2 ¹⁶ (65,536)					
Output resolution	Pulse/rev	6,684,672	10,616,832	13,238,272	15,859,712	21,102,592	
Mass (without brake)	kg	2.0					
Mass (with brake)	kg	2.1					
Environmental conditions		Operating temperature: 0 to 40°C/Storage temperature: -20 to 60°C Operating humidity/storage humidity: 20 to 80%RH (no condensation) Resistance to vibration: 25 m/s ² (frequency: 10 to 400Hz)/Shock resistance: 300 m/s ² *4 No dust, no metal powder, no corrosive gas, no inflammable gas, no oil mist To be used indoors, no direct sunlight Altitude: less than 1,000 m above sea level					
Motor insulation		Insulation resistance: 100MΩ or more (by DC500V insulation tester) Dielectric strength: AC1,500V/1 min Insulation class: A					
Mounting direction		Can be installed in any direction.					
Protection structure		Totally enclosed self-cooled type (IP54)					

The table shows typical output values of actuators.

*1: Typical characteristics when combined (driven by ideal sine wave) with our drivers.

*2: Value after temperature rise and saturation when the 320 x 320 x 16 [mm] aluminum radiation plate is installed.

*3: Value of phase induced voltage constant multiplied by 3.

*4: For testing conditions, refer to [1-12 Shock resistance] (P1-42) and [1-13 Vibration resistance] (P1-43).

SG/HP type

Item	Model	SHA25A (Motor input voltage 100V)					SHA25A (Motor input voltage 200V)						
		51	81	101	121	161	11	51	81	101	121	161	
Servo Drive		REL-230-18 HA-800□-6D/E-100					REL-230-18 REL-230-36 HA-800□-3D/E-200						
Max. torque ^{*1}	Nm	127	178	204	217	229	26	127	178	204	217	229	
	kgf·m	13	18.2	20.8	22.1	23.4	2.7	13	18.2	20.8	22.1	23.4	
Allowable continuous torque ^{*1*2}	Nm	35	58	73	81	81	9.0	41	67	81	81	81	
	kgf·m	3.6	5.9	7.4	8.2	8.2	0.92	4.2	6.8	8.2	8.2	8.2	
Max. rotational speed ^{*1}	rpm	94.1	59.3	47.5	39.7	29.8	509.1	109.8	69.1	55.4	46.3	34.8	
Torque constant ^{*1}	Nm/A	11.1	17.9	22	27	36	4.2	19	31	39	46	62	
	kgf·m/A	1.1	1.8	2.3	2.7	3.6	0.43	2.0	3.2	4.0	4.7	6.3	
Max. current ^{*1}	A	14.9	13.0	12.1	10.9	9.0	8.9	8.6	7.5	7.0	6.3	5.2	
Allowable continuous current ^{*1*2}	A	4.7	4.7	4.7	4.5	3.7	3.0	3.0	3.0	2.9	2.6	2.1	
MEF constant ^{*3}	V/(rpm)	1.3	2.0	2.5	3.0	4.0	0.47	2.2	3.5	4.3	5.2	6.9	
Phase resistance (20°C)	Ω	0.4					1.2						
Phase inductance	mH	1.0					3						
Inertia moment (without brake)	GD ² /4	kg·m ²	0.56	1.4	2.2	3.2	5.6	0.029	0.56	1.4	2.2	3.2	5.6
	J	kgf·cm·s ²	5.7	14	22	32	57	0.30	5.7	14	22	32	57
Inertia moment (with brake)	GD ² /4	kg·m ²	0.66	1.7	2.6	3.7	6.6	0.034	0.66	1.7	2.6	3.7	6.6
	J	kgf·cm·s ²	6.7	17	26	38	67	0.35	6.7	17	26	38	67
Reduction ratio		1:51	1:81	1:101	1:121	1:161	1:11	1:51	1:81	1:101	1:121	1:161	
Permissible moment load	Nm	258					410	258					
	kgf·m	26.3					41.8	26.3					
Moment stiffness	Nm/rad	39.2 x 10 ⁴					37.9 x 10 ⁴	39.2 x 10 ⁴					
	kgf·m/arc min	11.6					11.3	11.6					
One-way positional accuracy	Sec.	50	40	40	40	40	120	50	40	40	40	40	
Encoder type		Magnetic absolute encoder											
Single motor revolution Encoder resolution		2 ¹⁷ (131,072)											
Motor multi revolution counter		2 ¹⁶ (65,536)											
Output resolution	Pulse/rev	6,684, 672	10,616, 832	13,238, 272	15,859, 712	21,102, 592	1,441, 792	6,684, 672	10,616, 832	13,238, 272	15,859, 712	21,102, 592	
Mass (without brake)	kg	2.95					5.0	2.95					
Mass (with brake)	kg	3.1					5.1	3.1					
Environmental conditions		Operating temperature: 0 to 40°C/Storage temperature: -20 to 60°C Operating humidity/storage humidity: 20 to 80%RH (no condensation) Resistance to vibration: 25 m/s ² (frequency: 10 to 400Hz)/Shock resistance: 300 m/s ² *4 No dust, no metal powder, no corrosive gas, no inflammable gas, no oil mist To be used indoors, no direct sunlight Altitude: less than 1,000 m above sea level											
Motor insulation		Insulation resistance: 100MΩ or more (by DC500V insulation tester) Dielectric strength: AC1,500V/1 min Insulation class: A											
Mounting direction		Can be installed in any direction.											
Protection structure		Totally enclosed self-cooled type (IP54)											

The table shows typical output values of actuators.

*1: When combined with a HA-800 driver..

*2: Value after temperature rise and saturation when the 350 x 350 x 18 [mm] aluminum radiation plate is installed.

*3: Value of phase induced voltage constant multiplied by 3.

*4: For testing conditions, refer to [1-12 Shock resistance] (P1-42) and [1-13 Vibration resistance] (P1-43).

SG/HP type

Item	Model	SHA32A						
		11	51	81	101	121	161	
Servo Drive		REL-230-18, REL-230-36 HA-800□-6D/E-200						
Max. torque ^{*1}	Nm	62	281	395	433	459	484	
	kgf·m	6.3	28.7	40.3	44.2	46.8	49.4	
Allowable continuous torque ^{*1*2}	Nm	20	92	153	178	178	178	
	kgf·m	2.1	9.4	15.6	18.2	18.2	18.2	
Max. rotational speed ^{*1}	r/min	436.4	94.1	59.3	47.5	39.7	29.8	
Torque constant ^{*1}	Nm/A	4.5	21	33	42	50	66	
	kgf·m/A	0.46	2.1	3.4	4.2	5.1	6.8	
Max. current ^{*1}	A	19	17.3	15.2	13.5	12.2	9.9	
Allowable continuous current ^{*1*2}	A	6.0	6.0	6.0	5.7	5.0	4.1	
MEF constant ^{*3}	V/(r/min)	0.51	2.3	3.7	4.7	5.6	7.4	
Phase resistance (20°C)	Ω	0.33						
Phase inductance	mH	1.4						
Inertia moment (without brake)	GD ² /4	kg·m ²	0.091	2.0	5.1	8.0	11	20
	J	kgf·cm·s ²	0.93	21	52	81	117	207
Inertia moment (with brake)	GD ² /4	kg·m ²	0.11	2.3	5.9	9.2	13	23
	J	kgf·cm·s ²	1.1	24	60	94	135	238
Reduction ratio		1:11	1:51	1:81	1:101	1:121	1:161	
Permissible moment load	Nm	932	580					
	kgf·m	95	59.1					
Moment stiffness	Nm/rad	86.1 x 10 ⁴	100 x 10 ⁴					
	kgf·m/arc min	25.7	29.6					
One-way positional accuracy	Sec.	120	50	40	40	40	40	
Encoder type		Magnetic absolute encoder						
Single motor revolution		2 ¹⁷ (131,072)						
Encoder resolution		2 ¹⁶ (65,536)						
Motor multi revolution counter		2 ¹⁶ (65,536)						
Output resolution	Pulse/rev	1,441,792	6,684,672	10,616,832	13,238,272	15,859,712	21,102,592	
Mass (without brake)	kg	9.4	5.9					
Mass (with brake)	kg	9.7	6.2					
Environmental conditions		Operating temperature: 0 to 40°C/Storage temperature: -20 to 60°C Operating humidity/storage humidity: 20 to 80%RH (no condensation) Resistance to vibration: 25 m/s ² (frequency: 10 to 400Hz)/Shock resistance: 300 m/s ² *4 No dust, no metal powder, no corrosive gas, no inflammable gas, no oil mist To be used indoors, no direct sunlight Altitude: less than 1,000 m above sea level						
Motor insulation		Insulation resistance: 100MΩ or more (by DC500V insulation tester) Dielectric strength: AC1,500V/1 min Insulation class: A						
Mounting direction		Can be installed in any direction.						
Protection structure		Totally enclosed self-cooled type (IP54)						

The table shows typical output values of actuators.

*1: When combined with a HA-800 driver..

*2: Value after temperature rise and saturation when the 400 x 400 x 20 [mm] aluminum radiation plate is installed.

*3: Value of phase induced voltage constant multiplied by 3.

*4: For testing conditions, refer to [1-12 Shock resistance] (P1-42) and [1-13 Vibration resistance] (P1-43).

SG type

Item	Model	SHA40A										
		51	81	101	121	161	51	81	101	121	161	
Servo Drive		HA-800□-6D/E-200 ^{*1}					REL-230-36, REL-230-40 HA-800□-24D/E-200					
Max. torque ^{*2}	Nm	340	560	686	802	841	523	675	738	802	841	
	kgf·m	34.7	57.1	70	81.8	85.8	53.4	68.9	75.3	81.8	85.8	
Allowable continuous torque ^{*2*3}	Nm	94	158	198	237	317	160	263	330	382	382	
	kgf·m	9.6	16.1	20.2	24.2	32.3	16.3	26.8	33.7	39	39	
Max. rotational speed ^{*2}	r/min	78.4	49.4	39.6	33.1	24.8	78.4	49.4	39.6	33.1	24.8	
Torque constant ^{*2}	Nm/A	25	41	51	61	81	25	41	51	61	81	
	kgf·m/A	2.6	4.1	5.2	6.2	8.2	2.6	4.1	5.2	6.2	8.2	
Max. current ^{*2}	A	18	18	18	17.9	14.6	26.7	21.8	19.4	17.9	14.6	
Allowable continuous current ^{*2*3}	A	6.0	6.0	6.0	6.0	6.0	9.0	9.0	9.0	8.8	7.2	
MEF constant ^{*4}	V/(r/min)	2.9	4.6	5.7	6.8	9.1	2.9	4.6	5.7	6.8	9.1	
Phase resistance (20°C)	Ω	0.19										
Phase inductance	mH	1.2										
Inertia moment (without brake)	GD ² /4	kg·m ²	5.0	13	20	28	50	5.0	13	20	28	50
	J	kgf·cm·s ²	51	130	202	290	513	51	130	202	290	513
Inertia moment (with brake)	GD ² /4	kg·m ²	6.1	15	24	34	61	6.1	15	24	34	61
	J	kgf·cm·s ²	62	157	244	350	619	62	157	244	350	619
Reduction ratio		1:51	1:81	1:101	1:121	1:161	1:51	1:81	1:101	1:121	1:161	
Permissible moment load	Nm	849										
	kgf·m	86.6										
Moment stiffness	Nm/rad	179 x 10 ⁴										
	kgf·m/arc min	53.2										
One-way positional accuracy	Sec.	50	40	40	40	40	50	40	40	40	40	
Encoder type		Magnetic absolute encoder										
Single motor revolution Encoder resolution		2 ¹⁷ (131,072)										
Motor multi revolution counter		2 ¹⁶ (65,536)										
Output resolution	Pulse/rev	6,684, 672	10,616, 832	13,238, 272	15,859, 712	21,102, 592	6,684, 672	10,616, 832	13,238, 272	15,859, 712	21,102, 592	
Mass (without brake)	kg	9.9										
Mass (with brake)	kg	10.7										
Environmental conditions		Operating temperature: 0 to 40°C/Storage temperature: -20 to 60°C Operating humidity/storage humidity: 20 to 80%RH (no condensation) Resistance to vibration: 25 m/s ² (frequency: 10 to 400Hz)/Shock resistance: 300 m/s ²⁻⁵ No dust, no metal powder, no corrosive gas, no inflammable gas, no oil mist To be used indoors, no direct sunlight Altitude: less than 1,000 m above sea level										
Motor insulation		Insulation resistance: 100MΩ or more (by DC500V insulation tester) Dielectric strength: AC1,500V/1 min Insulation class: A										
Mounting direction		Can be installed in any direction.										
Protection structure		Totally enclosed self-cooled type (IP54)										

The table shows typical output values of actuators.

*1: If a HA-800□-6D/E driver is combined with a SHA40A actuator, the maximum torque and allowable continuous torque are limited.

*2: When combined with HA-800 driver.

*3: Value after temperature rise and saturation when the 500 x 500 x 25 [mm] aluminum radiation plate is installed.

*4: Value of phase induced voltage constant multiplied by 3.

*5: For testing conditions, refer to [1-12 Shock resistance] (P1-42) and [1-13 Vibration resistance] (P1-43).

SG type

Item	Model	SHA58A				SHA65A				
		81	101	121	161	81	101	121	161	
Servo Drive		HA-800□-24D/E-200				HA-800□-24D/E-200				
Max. torque ^{*1}	Nm	1924	2067	2236	2392	2400	2990	3263	3419	
	kgf·m	196	211	228	244	245	305	333	349	
Allowable continuous torque ^{*1*2}	Nm	714	905	969	969	921	1149	1236	1236	
	kgf·m	73	92	99	99	94	117	126	126	
Max. rotational speed ^{*1}	rpm	37.0	29.7	24.8	18.6	34.6	27.7	23.1	17.4	
Torque constant ^{*1}	Nm/A	54	68	81	108	54	68	81	108	
	kgf·m/A	5.5	6.9	8.3	11.0	5.5	6.9	8.3	11.0	
Max. current ^{*1}	A	45	39	36	30	55	55	51	41	
Allowable continuous current ^{*1*2}	A	17.7	17.8	16.4	13.4	22.0	21.9	20.1	16.3	
MEF constant ^{*3}	V/(rpm)	6.1	7.6	9.1	12.1	6.1	7.6	9.1	12.1	
Phase resistance (20°C)	Ω	0.028				0.028				
Phase inductance	mH	0.29				0.29				
Inertia moment (without brake)	GD ² /4	kg·m ²	96	149	214	379	110	171	245	433
	J	kgf·cm·s ²	980	1520	2180	3870	1120	1740	2500	4420
Inertia moment (with brake)	GD ² /4	kg·m ²	106	165	237	420	120	187	268	475
	J	kgf·cm·s ²	1090	1690	2420	4290	1230	1910	2740	4850
Reduction ratio		1:81	1:101	1:121	1:161	1:81	1:101	1:121	1:161	
Permissible moment load	Nm	2180				2740				
	kgf·m	222				280				
Moment stiffness	Nm/rad	531 x 10 ⁴				741 x 10 ⁴				
	kgf·m/arc min	158				220				
One-way positional accuracy	Sec.	40	40	40	40	40	40	40	40	
Encoder type		Magnetic absolute encoder								
Single motor revolution Encoder resolution		2 ¹⁷ (131,072)								
Output resolution	Pulse/rev	10,616,832	13,238,272	15,859,712	21,102,592	10,616,832	13,238,272	15,859,712	21,102,592	
Mass (without brake)	kg	29.5				37.5				
Mass (with brake)	kg	32				40				
Environmental conditions		Operating temperature: 0 to 40°C/Storage temperature: -20 to 60°C Operating humidity/storage humidity: 20 to 80%RH (no condensation) Resistance to vibration: 25 m/s ² (frequency: 10 to 400Hz)/Shock resistance: 300 m/s ² *4 No dust, no metal powder, no corrosive gas, no inflammable gas, no oil mist To be used indoors, no direct sunlight Altitude: less than 1,000 m above sea level								
Motor insulation		Insulation resistance: 100MΩ or more (by DC500V insulation tester) Dielectric strength: AC1,500V/1 min Insulation class: A								
Mounting direction		Can be installed in any direction.								
Protection structure		Totally enclosed self-cooled type (IP54)								

The table shows typical output values of actuators.

*1: When combined with HA-800 driver.

*2: Value after temperature rise and saturation when the 650 x 650 x 30 [mm] aluminum radiation plate is installed.

*3: Value of phase induced voltage constant multiplied by 3.

*4: For testing conditions, refer to [1-12 Shock resistance] (P1-42) and [1-13 Vibration resistance] (P1-43).

CG type

Actuator Model		SHA20A					
		50	80	100	120	160	
Item							
Servo Drive		REL-230-18 HA-800□-3D/E-200					
Max. torque ^{*1}	Nm	73	96	107	113	120	
	kgf·m	7.4	9.8	10.9	11.5	12.2	
Allowable continuous torque ^{*1*2}	Nm	21	35	43	48	48	
	kgf·m	2.1	3.6	4.4	4.9	4.9	
Max. rotational speed ^{*1}	r/min	120	75	60	50	37.5	
Torque constant ^{*1}	Nm/A	16	26	33	39	53	
	kgf·m/A	1.7	2.7	3.4	4.0	5.4	
Max. current ^{*1}	A	6.1	5.0	4.6	4.1	3.4	
Allowable continuous current ^{*1*2}	A	2.1	2.1	2.1	2.0	1.7	
MEF constant ^{*3}	V/(rpm)	1.8	2.9	3.7	4.4	5.9	
Phase resistance (20°C)	Ω	1.4					
Phase inductance	mH	2.5					
Inertia moment (without brake)	GD ² /4	kg·m ²	0.21	0.53	0.82	1.2	2.1
	J	kgf·cm·s ²	2.1	5.4	8.0	12	22
Inertia moment (with brake)	GD ² /4	kg·m ²	0.23	0.60	0.94	1.3	2.4
	J	kgf·cm·s ²	2.4	6.1	9.6	14	24
Reduction ratio		1:50	1:80	1:100	1:120	1:160	
Permissible moment load	Nm	187					
	kgf·m	19.1					
Moment stiffness	Nm/rad	25.2 × 10 ⁴					
	kgf·m/arc min	7.5					
One-way positional accuracy	Sec	60	50	50	50	50	
Repeatability	Sec	±5					
Reverse positional accuracy	Sec	75	30	30	30	30	
Encoder type		Magnetic absolute encoder					
Single motor revolution Encoder resolution		2 ¹⁷ (131,072)					
Motor multi revolution counter		2 ¹⁶ (65,536)					
Output resolution	Pulse/rev	6,553,600	10,485,760	13,107,200	15,728,640	20,971,520	
Mass (without brake)	kg	2.6					
Mass (with brake)	kg	2.7					
Environmental conditions		Operating temperature: 0 to 40°C/Storage temperature: -20 to 60°C Operating humidity/storage humidity: 20 to 80%RH (no condensation) Resistance to vibration: 25 m/s ² (frequency: 10 to 400Hz)/Shock resistance: 300 m/s ² ^{*4} No dust, no metal powder, no corrosive gas, no inflammable gas, no oil mist To be used indoors, no direct sunlight Altitude: less than 1,000 m above sea level					
Motor insulation		Insulation resistance: 100MΩ or more (by DC500V insulation tester) Dielectric strength: AC1,500V/1 min Insulation class: A					
Mounting direction		Can be installed in any direction					
Protection structure		Totally enclosed self-cooled type (IP54)					

The table shows typical output values of actuators.

*1: Typical characteristics when combined with our HA-800 driver.

*2: Value after temperature rise and saturation when the 350 x 350 x 18 [mm] aluminum radiation plate is installed.

*3: Value of phase induced voltage constant multiplied by 3.

*4: For testing conditions, refer to [1-12 Shock resistance] (P1-42) and [1-13 Vibration resistance] (P1-43).

CG type		SHA25A(Motor input voltage 100V)					SHA25A(Motor input voltage 200V)					
Item	Model	50	80	100	120	160	50	80	100	120	160	
		Sevo Drive		REL-230-18 REL-230-36 HA-800□-6D/E-100 ^{*1}					REL-230-18 REL-230-36 HA-800□-3D/E-200			
Max. torque ^{*1}	Nm	127	178	204	217	229	127	178	204	217	229	
	kgf·m	13	18.2	20.8	22.1	23.4	13	18.2	20.8	22.1	23.4	
Allowable continuous torque ^{*1*2}	Nm	34	57	72	81	81	40	66	81	81	81	
	kgf·m	3.5	5.8	7.3	8.2	8.2	4.1	6.8	8.2	8.2	8.2	
Max. rotational speed ^{*1}	r/min	96	60	48	40	30	112	70	56	46.7	35	
Torque constant ^{*1}	Nm/A	10.9	17.7	22	27	35	19	31	38	46	61	
	kgf·m/A	1.1	1.8	2.3	2.7	3.6	1.9	3.1	3.9	4.7	6.3	
Max. current ^{*1}	A	15.1	13.2	12.2	11.0	9.0	8.7	7.6	7.0	6.3	5.2	
Allowable continuous current ^{*1*2}	A	4.7	4.7	4.7	4.5	3.7	3.0	3.0	3.0	2.6	2.1	
MEF constant ^{*3}	V/(rpm)	1.2	2.0	2.5	3.0	4.0	2.1	3.4	4.3	5.2	6.9	
Phase resistance (20°C)	Ω	0.4					1.2					
Phase inductance	mH	1.0					3.0					
Inertia moment (without brake)	GD ² /4	kg·m ²	0.50	1.3	2.0	2.9	5.1	0.50	1.3	2.0	2.9	5.1
	J	kgf·cm·s ²	5.1	13	20	29	52	5.1	13	20	29	52
Inertia moment (with brake)	GD ² /4	kg·m ²	0.60	1.5	2.4	3.4	6.1	0.60	1.5	2.4	3.4	6.1
	J	kgf·cm·s ²	6.1	16	24	35	62	6.1	16	24	35	62
Reduction ratio	mH	50:1	80:1	120:1	1:120	160:1	50:1	80:1	120:1	1:120	160:1	
Permissible moment load	Nm	258										
	kgf·m	26.3										
Moment stiffness	Nm/rad	39.2 × 10 ⁴										
	kgf·m/arc min	11.6										
One-way positional accuracy	Sec	50	40	40	40	40	50	40	40	40	40	
Repeatability	Sec	±5										
Reverse positional accuracy	Sec	60	25	25	25	25	60	25	25	25	25	
Encoder type		Magnetic absolute encoder										
Single motor revolution Encoder resolution		2 ¹⁷ (131,072)										
Motor multi revolution counter		2 ¹⁶ (65,536)										
Output resolution	Pulse/rev	6,553,600	10,485,760	13,107,200	15,728,640	20,971,520	6,553,600	10,485,760	13,107,200	15,728,640	20,971,520	
Mass (without brake)	kg	3.95										
Mass (with brake)	kg	4.1										

Environmental conditions	Operating temperature: 0 to 40°C/Storage temperature: -20 to 60°C Operating humidity/storage humidity: 20 to 80%RH (no condensation) Resistance to vibration: 25 m/s ² (frequency: 10 to 400Hz)/Shock resistance: 300 m/s ² *4 No dust, no metal powder, no corrosive gas, no inflammable gas, no oil mist To be used indoors, no direct sunlight Altitude: less than 1,000 m above sea level
Motor insulation	Insulation resistance: 100MΩ or more (by DC500V insulation tester) Dielectric strength: AC1,500V/1 min Insulation class: A
Mounting direction	Can be installed in any direction
Protection structure	Totally enclosed self-cooled type (IP54)

The table shows typical output values of actuators.

*1: Typical characteristics when combined (driven by ideal sine wave) with our drivers.

*2: Value after temperature rise and saturation when the 350 x 350 x 18 [mm] aluminum radiation plate is installed.

*3: Value of phase induced voltage constant multiplied by 3.

*4: For testing conditions, refer to [1-12 Shock resistance] (P1-42) and [1-13 Vibration resistance] (P1-43).

CG type

Model		SHA32A					
		50	80	100	120	160	
Servo Drive		REL-230-18 REL-230-36 HA-800□-6D/E-200					
Max. torque ^{*1}	Nm	281	395	433	459	484	
	kgf·m	28.7	40.3	44.2	46.8	49.4	
Allowable continuous torque ^{*1*2}	Nm	90	151	178	178	178	
	kgf·m	9.2	15.4	18.2	18.2	18.2	
Max. rotational speed ^{*1}	r/min	96	60	48	40	30	
Torque constant ^{*1}	Nm/A	20	33	41	49	66	
	kgf·m/A	2.1	3.4	4.2	5.0	6.7	
Max. current ^{*1}	A	17.7	15.4	13.7	12.2	10	
Allowable continuous current ^{*1*2}	A	6.0	6.0	5.7	5.0	4.1	
MEF constant ^{*3}	V/(rpm)	2.3	3.7	4.6	5.5	7.4	
Phase resistance (20°C)	Ω	0.33					
Max. current ^{*1}	mH	1.4					
Inertia moment (without brake)	GD ² /4	kg·m ²	1.7	4.3	6.7	9.7	17
	J	kgf·cm·s ²	17	44	68	99	175
Inertia moment (with brake)	GD ² /4	kg·m ²	2.0	5.1	7.9	11	20
	J	kgf·cm·s ²	20	52	81	116	207
Reduction ratio		50:1	80:1	100:1	120:1	160:1	
Permissible moment load	Nm	580					
	kgf·m	59.2					
Moment stiffness	Nm/rad	100 × 10 ⁴					
	kgf·m/arc min	29.6					
One-way positional accuracy	Sec	40	30	30	30	30	
Repeatability	Sec	±4					
Reverse positional accuracy	Sec	60	25	25	25	25	
Encoder type		Magnetic absolute encoder					
Single motor revolution		2 ¹⁷ (131,072)					
Encoder resolution		2 ¹⁶ (65,536)					
Motor multi revolution counter		2 ¹⁶ (65,536)					
Output resolution	Pulse/rev	6,553,600	10,485,760	13,107,200	15,728,640	20,971,520	
Mass (without brake)	kg	7.7					
Mass (with brake)	kg	8.0					

Environmental conditions	Operating temperature: 0 to 40°C/Storage temperature: -20 to 60°C Operating humidity/storage humidity: 20 to 80%RH (no condensation) Resistance to vibration: 25 m/s ² (frequency: 10 to 400Hz)/Shock resistance: 300 m/s ² *4 No dust, no metal powder, no corrosive gas, no inflammable gas, no oil mist To be used indoors, no direct sunlight Altitude: less than 1,000 m above sea level
Motor insulation	Insulation resistance: 100MΩ or more (by DC500V insulation tester) Dielectric strength: AC1,500V/1 min Insulation class: A
Mounting direction	Can be installed in any direction.
Protection structure	Totally enclosed self-cooled type (IP54)

The table shows typical output values of actuators.

*1: Typical characteristics when used with HA-800.

*2: Value after temperature rise and saturation when the 400 x 400 x 20 [mm] aluminum radiation plate is installed.

*3: Value of phase induced voltage constant multiplied by 3.

*4: For testing conditions, refer to [1-12 Shock resistance] (P1-42) and [1-13 Vibration resistance] (P1-43).

CG type		SHA40A										
Model		50	80	100	120	160	50	80	100	120	160	
Item		HA-800□-6D/E-200 ^{*1}					REL-230-36, REL-230-40 HA-800□-24D/E-200					
Max. torque ^{*2}	Nm	333	548	686	802	841	523	675	738	802	841	
	kgf·m	34.0	55.9	70.0	81.8	85.8	53.4	68.9	75.3	81.8	85.8	
Allowable continuous torque ^{*2,3}	Nm	92	156	196	235	315	157	260	327	382	382	
	kgf·m	9.4	15.9	20.0	24.0	32.1	16.0	26.5	33.3	39	39	
Max. rotational speed ^{*2}	rpm	80	50	40	33.3	25	80	50	40	33.3	25	
Torque constant ^{*2}	Nm/A	25	40	50	60	80	25	40	50	60	80	
	kgf·m/A	2.5	4.1	5.1	6.1	8.2	2.5	4.1	5.1	6.1	8.2	
Max. current ^{*1}	A	18	18	18	17.6	14.3	27.2	22	19.6	18	14.7	
Allowable continuous current ^{*1,2}	A	6.0	6.0	6.0	6.0	6.0	9.0	9.0	9.0	8.8	7.2	
MEF constant	V/(rpm)	2.8	4.5	5.6	6.7	9.0	2.8	4.5	5.6	6.7	9.0	
Phase resistance (20°C)	Ω	0.19										
Phase inductance	mH	1.2										
Inertia moment (without brake)	GD ² /4	kg·m ²	4.8	12	19	27	49	4.8	12	19	27	49
	J	kgf·cm·s ²	49	124	194	280	497	49	124	194	280	497
Inertia moment (with brake)	GD ² /4	kg·m ²	5.8	15	23	33	59	5.8	15	23	33	59
	J	kgf·cm·s ²	59	150	235	338	601	59	150	235	338	601
Reduction ratio		50:1	80:1	100:1	120:1	160:1	50:1	80:1	100:1	120:1	160:1	
Permissible moment load	Nm	849										
	kgf·m	86.6										
Moment stiffness	Nm/rad	179 × 10 ⁴										
	kgf·m/arc min	53.2										
One-way positional accuracy	Sec	40	30	30	30	30	40	30	30	30	30	
Repeatability	Sec	±4										
Reverse positional accuracy	Sec	50	20	20	20	20	50	20	20	20	20	
Encoder type		Magnetic absolute encoder										
Single motor revolution Encoder resolution		2 ¹⁷ (131,072)										
Motor multi revolution count		2 ¹⁶ (65,536)										
Output resolution	Pulse/rev	6,553,600	10,485,760	13,107,200	15,728,640	20,971,520	6,553,600	10,485,760	13,107,200	15,728,640	20,971,520	
Mass (without brake)	kg	13.0										
Mass (with brake)	kg	13.8										

Environmental conditions	Operating temperature: 0 to 40°C/Storage temperature: -20 to 60°C Operating humidity/storage humidity: 20 to 80%RH (no condensation) Resistance to vibration: 25 m/s ² (frequency: 10 to 400Hz)/Shock resistance: 300 m/s ² *4 No dust, no metal powder, no corrosive gas, no inflammable gas, no oil mist To be used indoors, no direct sunlight Altitude: less than 1,000 m above sea level
Motor insulation	Insulation resistance: 100MΩ or more (by DC500V insulation tester) Dielectric strength: AC1,500V/1 min Insulation class: A
Mounting direction	Can be installed in any direction.
Protection structure	Totally enclosed self-cooled type (IP54)

The table shows typical output values of actuators.

*1: If a HA-800□-6D/E driver is combined with a SHA40A actuator, the maximum torque and allowable continuous torque are limited.

*2: Typical characteristics when combined (driven by ideal sine wave) with our drivers.

*3: Value after temperature rise and saturation when the 500 x 500 x 25 [mm] aluminum radiation plate is installed.

*4: Value of phase induced voltage constant multiplied by 3.

*5: For testing conditions, refer to [1-12 Shock resistance] (P1-42) and [1-13 Vibration resistance] (P1-43).

1-5 Motor shaft brake

The brake is used to hold the motor shaft in place when the power is turned off. With smaller sizes (SHA25A, 32A), the actuator's built-in circuit controls the voltage supplied to the brake in order to reduce the power consumption while the brake is actuated.

Be sure to use a DC power supply having proper brake excitation voltage and capable of outputting enough current for the brake actuation (release).

Specifications

SG/HP type

Item		Model	SHA20A				
			51	81	101	121	161
Type			Dry non-excitation actuation type (without power-saving control)				
Brake excitation voltage	V		DC24V \pm 10% (no polarity) ¹				
Current consumption during suction (at 20°C)	A		0.37				
Current consumption during holding (at 20°C)	A		Same as current consumption during suction				
Holding torque ³	Nm		31	49	61	73	97
	kgf·m		3.1	5.0	6.2	7.4	9.9
Inertia moment ³ (Actuator total) (with brake)	(GD ² /4) kg·m ²		0.26	0.65	1.0	1.4	2.6
	(J) kgf·cm·s ²		2.7	6.6	10	15	26
Mass (with brake) ⁴	kg		2.1				
Allowable number of normal stops ⁵			100,000 times				
Allowable number of emergency stops ⁶			200 times				

Item		Model	SHA25A						SHA32A					
			11	51	81	101	121	161	11	51	81	101	121	161
Type			Dry non-excitation actuation type (with power-saving control)											
Brake excitation voltage	V		DC24V \pm 10% (no polarity) ¹											
Current consumption during suction (at 20°C)	A		0.8 ²						0.8 ²					
Current consumption during holding (at 20°C)	A		0.3						0.3					
Holding torque ³	Nm		11	51	81	101	121	161	22	102	162	202	242	322
	kgf·m		1.1	5.2	8.3	10	12	16	2.2	10	17	21	25	33
Inertia moment ³ (Actuator total) (with brake)	(GD ² /4) kg·m ²		0.034	0.66	1.7	2.6	3.7	6.6	1.7	2.3	5.9	9.2	13	23
	(J) kgf·cm·s ²		0.35	6.7	17	26	38	67	17	24	60	94	135	238
Mass (with brake) ⁴	kg		5.1	3.1				9.7	6.2					
Allowable number of normal stops ⁵			100,000 times											
Allowable number of emergency stops ⁶			200 times											

1-5 Motor shaft brake

Item		Model	SHA40A					SHA58A				
			51	81	101	121	161	81	101	121	161	
Type			Dry non-excitation actuation type (without power-saving control)									
Brake excitation voltage	V		DC24V ± 10% (no polarity) ¹									
Current consumption during suction (at 20°C)	A		0.7					0.9				
Current consumption during holding (at 20°C)	A		Same as current consumption during suction									
Holding torque ³	Nm		204	324	404	484	644	1220	1520	1820	2420	
	kgf·m		21	33	41	49	66	124	155	185	246	
Inertia moment ³ (Actuator total) (With brake)	(GD ² /4) kg·m ²		6.1	15	24	34	61	106	165	237	420	
	(J) kgf·cm·s ²		62	157	244	350	619	1090	1690	2420	4290	
			10.7					32				
Mass (with brake) ⁴	kg		10.7					32				
Allowable number of normal stops ⁵			100,000 times									
Allowable number of emergency stops ⁶			200 times									

Item		Model	SHA65A			
			81	101	121	161
Type			Dry non-excitation actuation type (without power-saving control)			
Brake excitation voltage	V		DC24V±10% (no polarity) ¹			
Current consumption during suction (at 20°C)	A		0.9			
Current consumption during holding (at 20°C)	A		Same as current consumption during suction			
Holding torque ³	Nm		1220	1520	1820	2420
	kgf·m		124	155	185	246
Inertia moment ³ (Actuator total) (With brake)	(GD ² /4) kg·m ²		120	187	268	475
	(J) kgf·cm·s ²		1230	1910	2740	4850
			40			
Mass (with brake) ⁴	kg		40			
Allowable number of normal stops ⁵			100,000 times			
Allowable number of emergency stops ⁶			200 times			

CG type

Item		Model	SHA20A					SHA25A				
			50	80	100	120	160	50	80	100	120	160
Type			Dry non-excitation actuation type (without power-saving control)					Dry non-excitation actuation type (with power-saving control)				
Brake excitation voltage	V		DC24V ± 10% (no polarity) ¹									
Current consumption during suction (at 20°C)	A		0.37					0.8 ²				
Current consumption during holding (at 20°C)	A		Same as current consumption during suction					0.3				
Holding torque ³	Nm		30	48	60	72	96	50	80	100	120	160
	kgf·m		3.1	4.9	6.1	7.3	9.8	5.1	8.2	10	12	16
Inertia moment ³ (Actuator total) (With brake)	(GD ² /4) kg·m ²		0.23	0.6	0.94	1.3	2.4	0.60	1.5	2.4	3.4	6.1
	(J) kgf·cm·s ²		2.4	6.1	9.6	14	24	6.1	16	24	35	62
			2.7					4.1				
Mass (with brake) ⁴	kg		2.7					4.1				
Allowable number of normal stops ⁵			100,000 times									
Allowable number of emergency stops ⁶			200 times									

Item		Model	SHA32A					SHA40A				
			50	80	100	120	160	50	80	100	120	160
Type			Dry non-excitation actuation type (with power-saving control)					Dry non-excitation actuation type (without power-saving control)				
Brake excitation voltage	V		DC24V±10%(no polarity) ^{*1}									
Current consumption during suction (at 20°C)	A		0.8 ^{*2}					0.7				
Current consumption during holding (at 20°C)	A		0.3					Same as current consumption during suction				
Holding torque ^{*3}	Nm		100	160	200	240	320	200	320	400	480	640
	kgf·m		10	16	20	24	33	20	33	41	49	65
Inertia moment ^{*3} (Actuator total) (With brake)	(GD ² /4) kg·m ²		2.0	5.1	7.9	11	20	5.8	15	23	33	59
	(J)		20	52	81	116	207	59	150	235	338	601
	kgf·cm·s ²											
Mass (with brake) ^{*4}	kg		8.0					13.8				
Allowable number of normal stops ^{*5}			100,000 times									
Allowable number of emergency stops ^{*6}			200 times									

*1: Power supply is user's responsibility. Use a power supply capable of outputting enough current consumption during suction for the brake.

*2: The duration for current consumption during suction is 0.5 second or less for the power supply of DC24V ± 10%.

*3: The values are converted for the output shaft of the actuator.

*4: The values present total mass of the actuator.

*5: The service time for normal holding is assured when the brake activates at motor shaft rotation speed of 150 rpm or less.

*6: The service time for emergency stop is assured when the brake activates at motor speed of 3,000 rpm or less provided the load inertia moment is 3 times of less than that of the actuator.



The motor shaft holding brake cannot be used for deceleration.
Do not use the holding brake more than the allowable number of normal brakings (100,000 times at the motor shaft rotation speed of 150 rpm or less) or allowable number of emergency stops (200 times with the motor shaft rotation speed of 3,000 rpm, provided the load inertia moment is 3 times or less than that of the actuator).

Exceeding the allowable number of normal stops or allowable number of emergency stops may deteriorate holding torque, and may consequently fail to properly serve as a brake.

1-6 External dimensions

- SHA20A-SG

Unit: mm

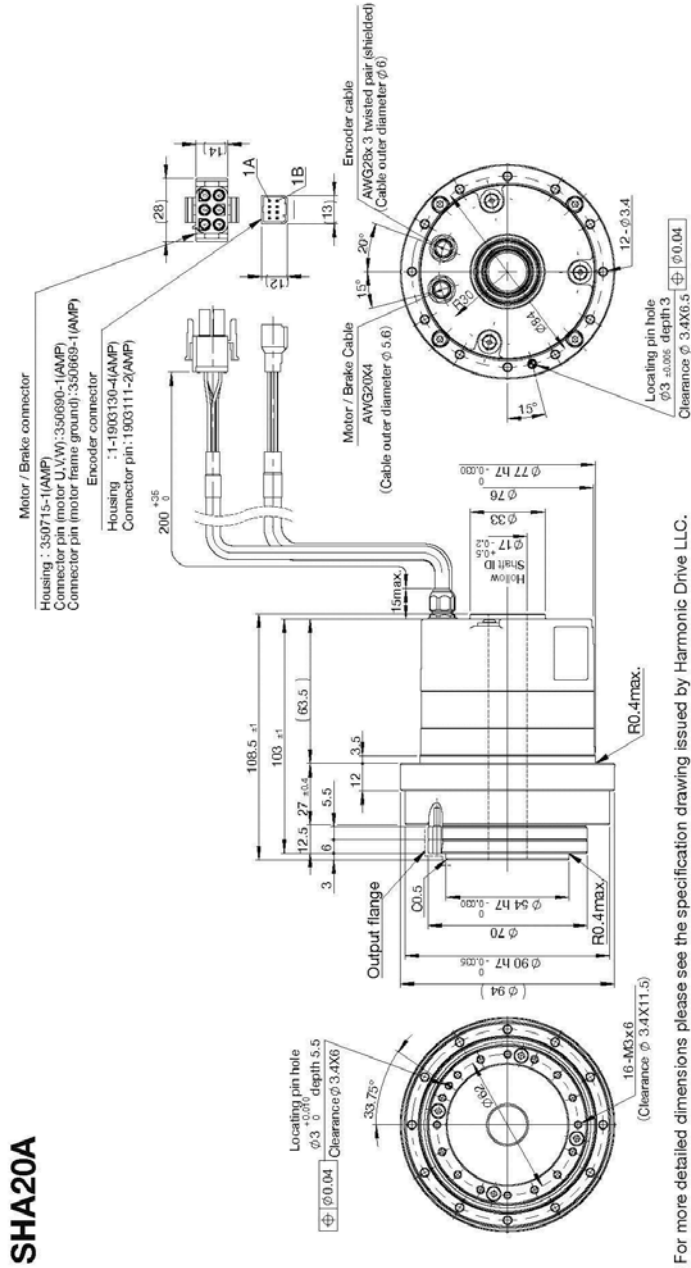

Note: For more detailed dimensions please see the specification drawing issued by Harmonic Drive LLC.

Note: The dimension tolerances that are not specified vary depending on the manufacturing method. Please check the confirmation drawing or contact us for dimension tolerances not shown

● SHA20A-CG

Unit: mm

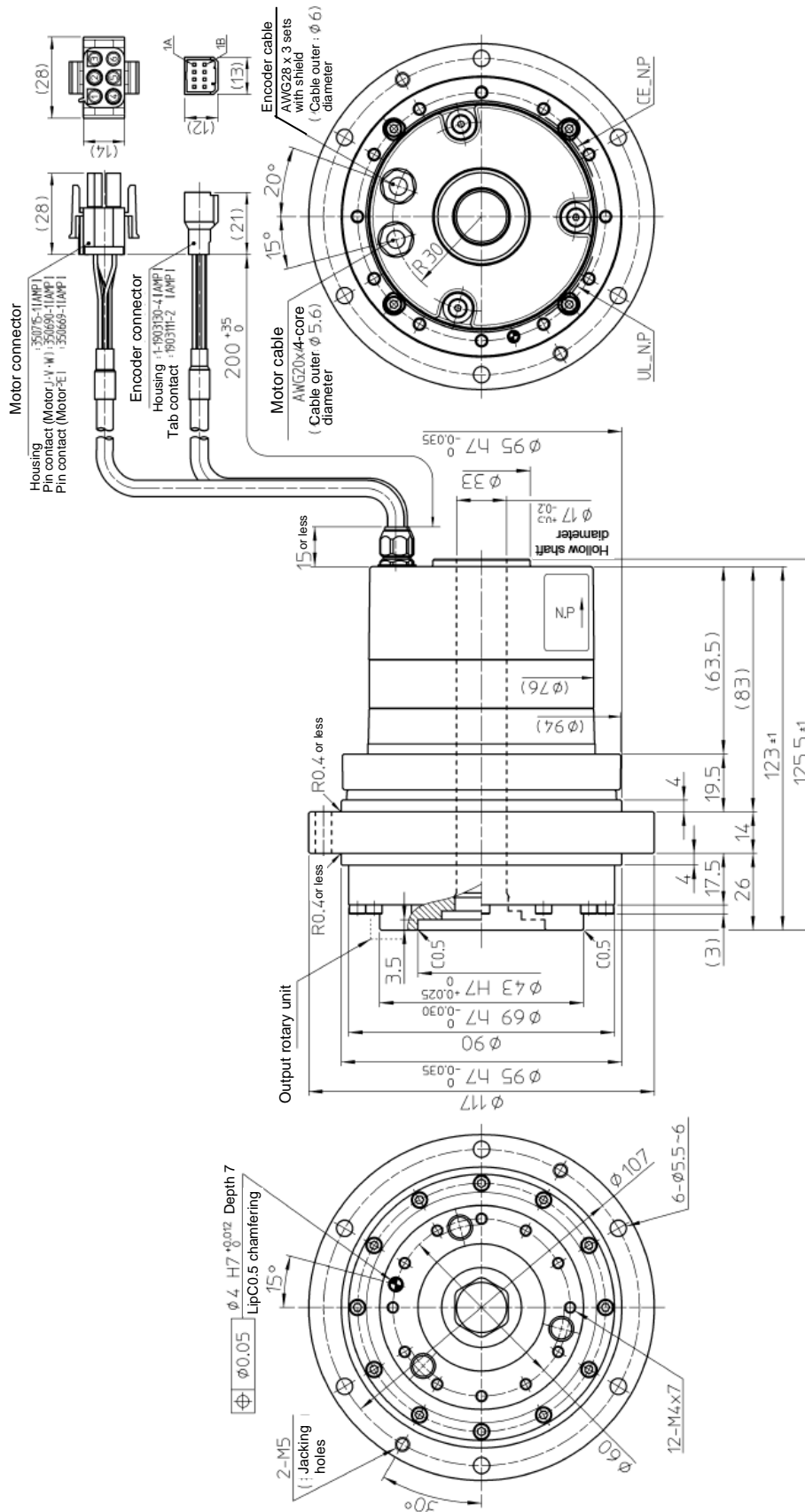

Note: The dimension tolerances that are not specified vary depending on the manufacturing method. Please check the confirmation drawing or contact us for dimension tolerances not shown

● SHA25A-HP

Unit: mm

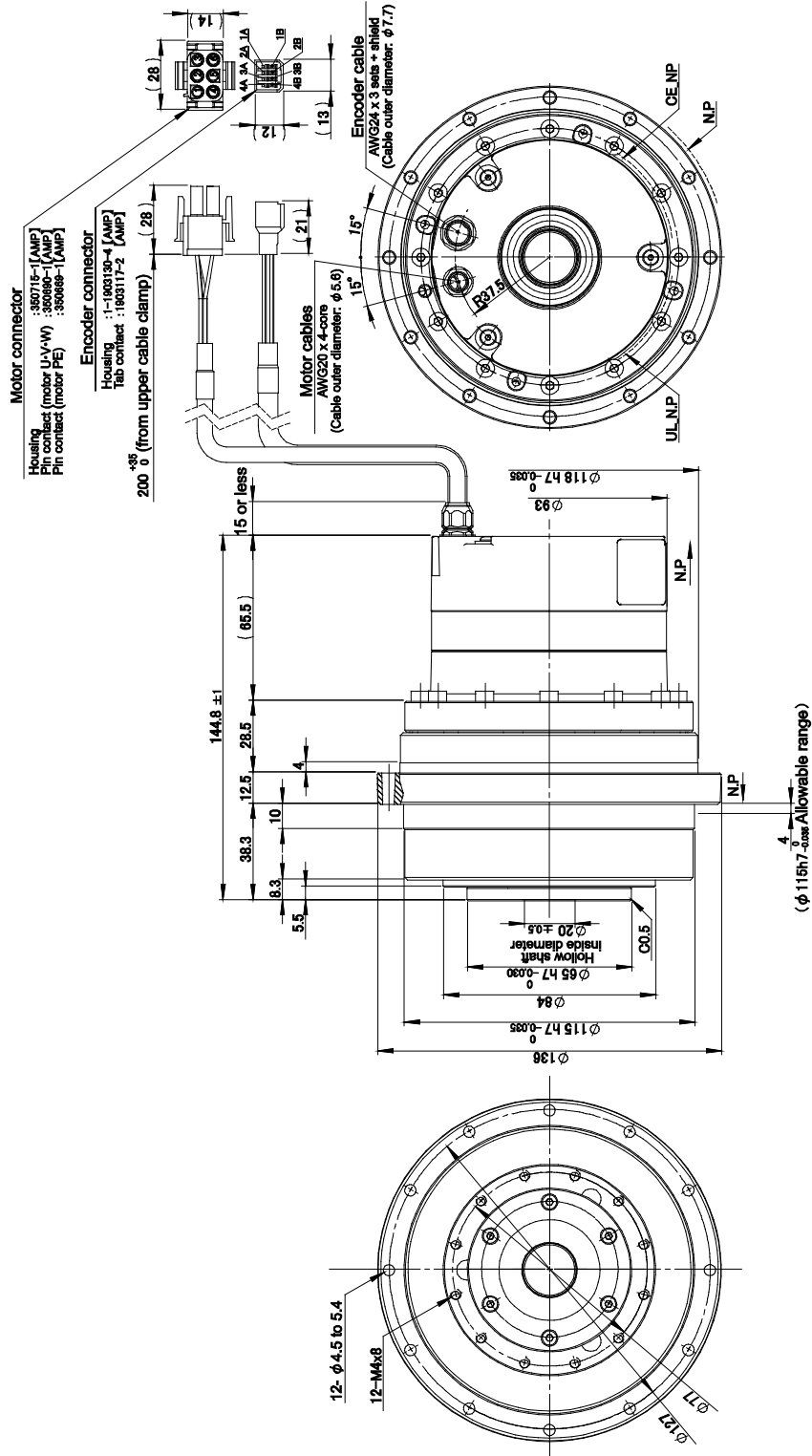

Note: The dimension tolerances that are not specified vary depending on the manufacturing method. Please check the confirmation drawing or contact us for dimension tolerances not shown

SHA25A-CG

Unit: mm

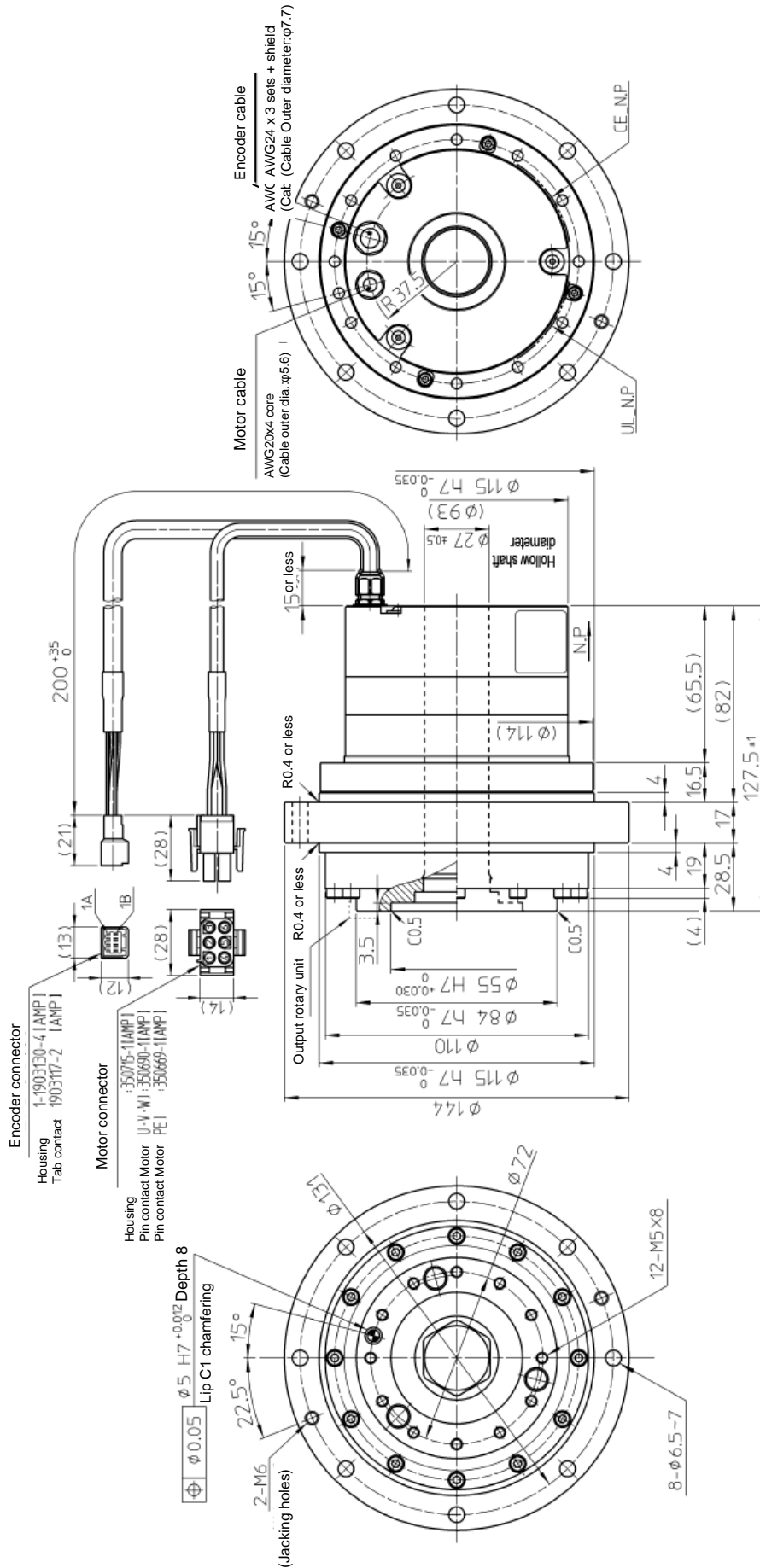

Note: The dimension tolerances that are not specified vary depending on the manufacturing method. Please check the confirmation drawing or contact us for dimension tolerances not shown

● SHA40A-CG

Unit: mm

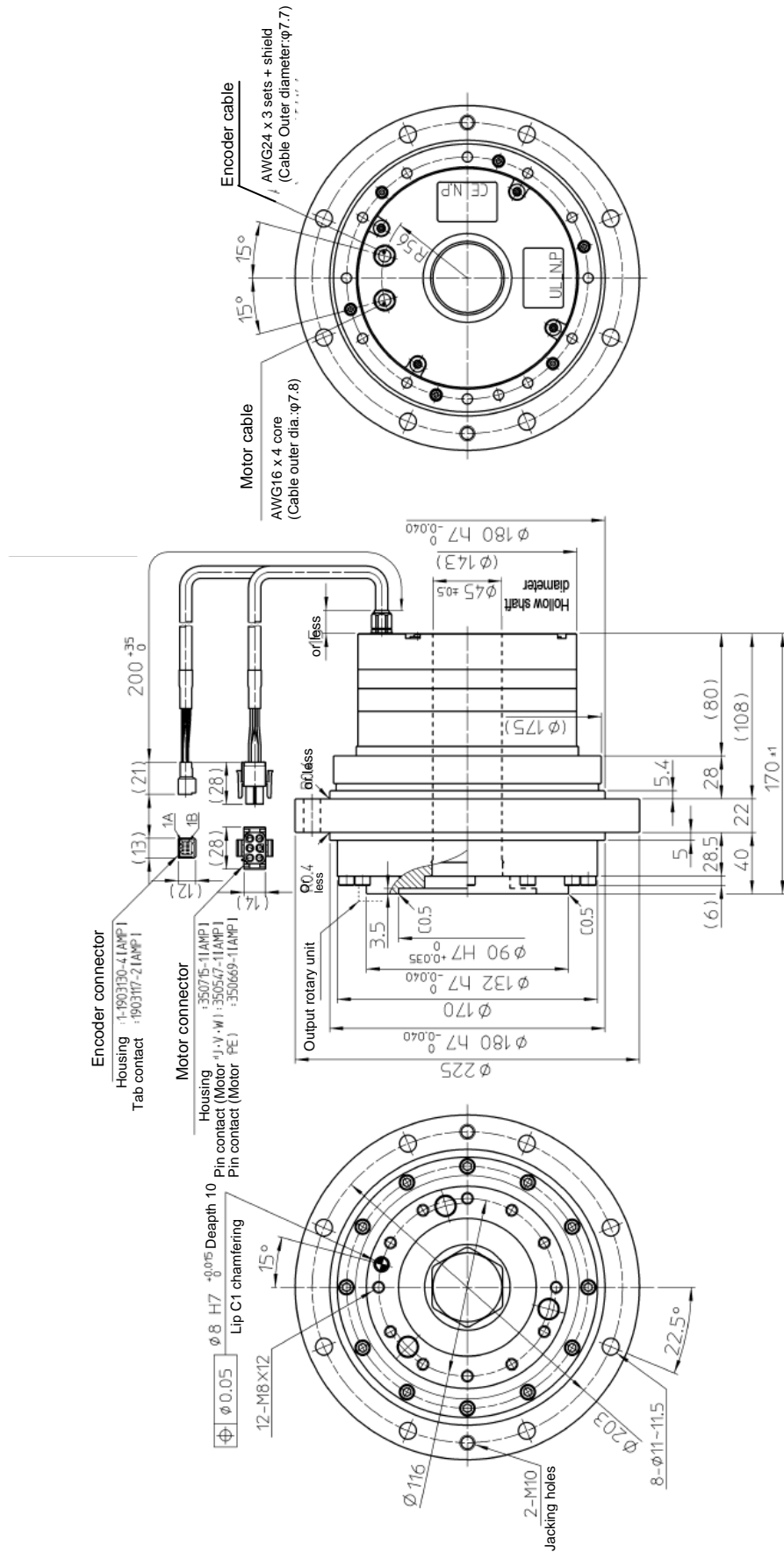

Note: The dimension tolerances that are not specified vary depending on the manufacturing method. Please check the confirmation drawing or contact us for dimension tolerances not shown

1-7 Mechanical accuracy

SHA series mechanical accuracy of the output shaft and mounting flange:

SG/HP type

unit: mm

Accuracy items	SHA20A	SHA25A	SHA32A	SHA40A	SHA58A	SHA65A
1. Output shaft surface runout	0.030	0.035 (0.020)	0.040 (0.020)	0.045	0.050	0.050
2. Output shaft radial run-out	0.030	0.035	0.040	0.045	0.050	0.050
3. Parallelism between the output shaft and actuator mounting surface	0.030	0.035	0.040	0.045	0.050	0.050
4. Parallelism between the output shaft and actuator mounting surface	0.055	0.050	0.055	0.060	0.070	0.070
5. Concentricity between the output shaft and actuator mounting diameter	0.030	0.035	0.040	0.045	0.050	0.050
6. Concentricity between the output shaft and actuator mounting diameter	0.045	0.060	0.065	0.070	0.080	0.080

Note: All values are T.I.R. (Total Indicator Reading).

The values in parenthesis are those combined with the hollow planetary speed reducer HPF series for precision control.

CG type

unit: mm

Accuracy items	SHA20A	SHA25A	SHA32A	SHA40A
1. Output shaft surface runout	0.010	0.010	0.010	0.010
2-1. Output shaft radial run-out (Outside inlay)	0.010	0.010	0.010	0.010
2-2. Output shaft radial run-out (Inside inlay)	0.015	0.015	0.015	0.015
3. Parallelism between the output shaft and actuator mounting surface	0.030	0.030	0.035	0.035
4. Parallelism between the output shaft and actuator mounting surface	0.040	0.040	0.045	0.045
5. Concentricity between the output shaft and actuator mounting diameter	0.050	0.050	0.055	0.060
6. Concentricity between the output shaft and actuator mounting diameter	0.060	0.060	0.065	0.070

Note: All values are T.I.R. (Total Indicator Reading).

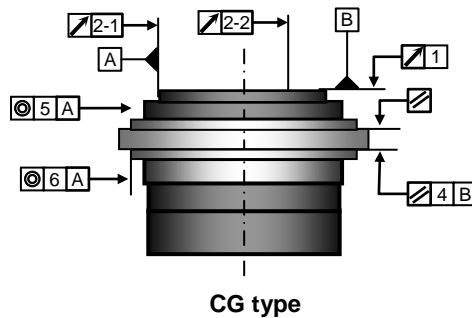
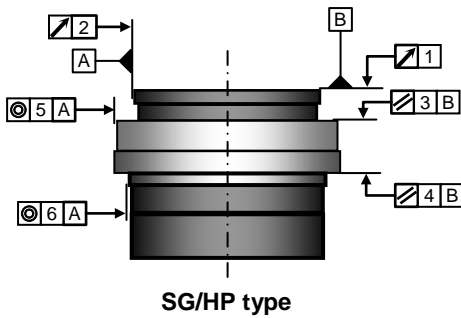

The reported values are measured as follows:

1 Output shaft surface runout

The indicator is fixed and measures the axial run-out (T.I.R.) of the outermost circumference of the output shaft for one revolution.

2 Output shaft radial run-out

The indicator is fixed and measures the radial run-out (T.I.R.) of the output shaft for one revolution..

3,4 Concentricity between the output shaft and actuator mounting diameter

The indicator is mounted on the output shaft and measures the axial run-out (T.I.R.) of the outermost circumference of the mounting surface (on both the output shaft side and opposite side) for one revolution.

5,6 Concentricity between the output shaft and actuator mounting diameter

The indicator on the output rotary unit measures the radial runout (maximum runout width) of the fitting part (both on the output shaft side and opposite side) of the output rotary unit per revolution.

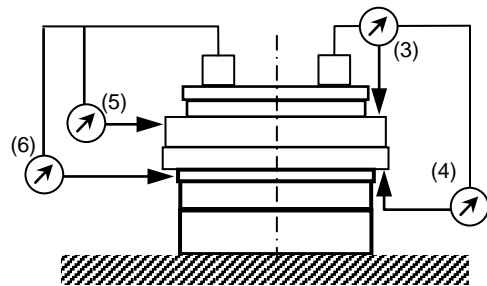
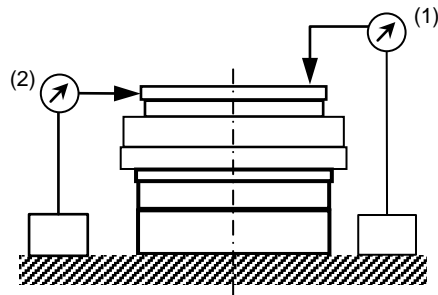

1-8 Positional accuracy

One-way positional accuracy

The one-way positional accuracy is defined as the maximum positional difference between the actual measured angle from the datum position and its theoretical rotational angle when a series of positioning moves are performed in the same rotational direction. (Refer to JIS B-6201-1987.) Since the SHA series incorporates a speed reducer for precision control, the impact of motor shaft positioning error becomes 1/multiple of reduction ratio.

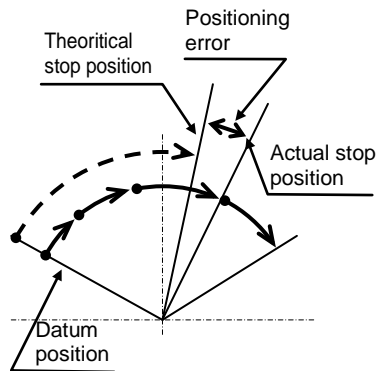

The one-way positional accuracy is shown in the table below:

SG/HP type

(Unit: Second)

Reduction ratio \ Model	SHA20A	SHA 25A	SHA32A	SHA40A	SHA58A	SHA65A
11:1	—	120	120	—	—	—
51:1	60	50	50	50	—	—
81:1 or more	50	40	40	40	40	40

CG type

(Unit: Second)

Reduction ratio \ Model	SHA20A	SHA25A	SHA32A	SHA40A
50:1	60	50	40	40
80:1 or more	50	40	30	30

Repeatability (CG type)

The repeatability is measured by moving to a given theoretical position seven times, each time approaching from the same direction. The actual position of the output shaft is measured each time and repeatability is calculated as the 1/2 of the maximum difference of the seven data points. Measured values are indicated in angles (arc-sec) prefixed with "±".

CG type

(Unit: Second)

Reduction ratio \ Model	SHA20A	SHA25A	SHA32A	SHA40A
Ratio to full speed	±5	±5	±4	±4

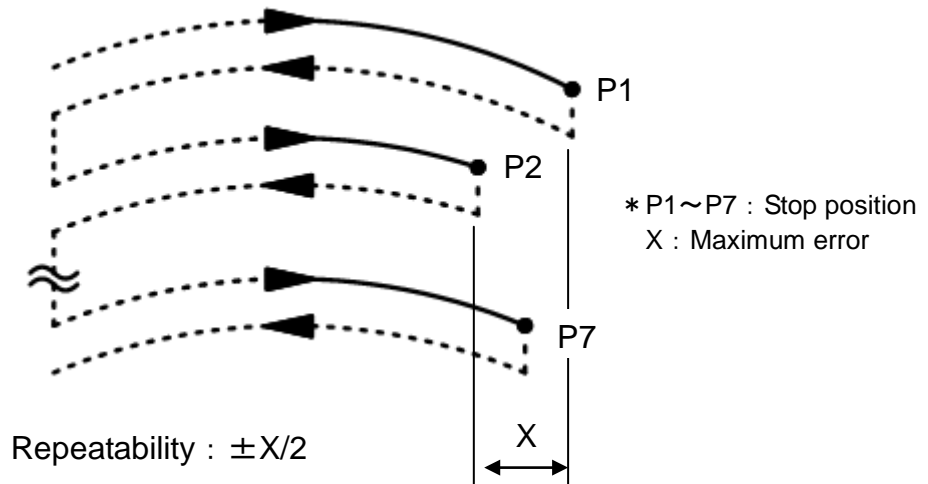

Reverse positional accuracy (CG type)

For the "reverse positional accuracy", the shaft is rotated beforehand in the forward (or reverse) direction and the stop position for that rotation is set as the reference position. An instruction is given to rotate the shaft in the same direction and from the stopped position, the same instruction is given in the reverse (or forward) direction and the difference between the stop position after this rotation and the reference position is measured. The average value from repeating this 7 times in each direction is shown and the maximum value measured at the 4 locations on the output shaft is shown.

CG type

(Unit: Second)

Model	SHA20A	SHA25A	SHA32A	SHA40A
Reduction ratio				
50:1	75	60	60	50
80:1 of more	30	25	25	20

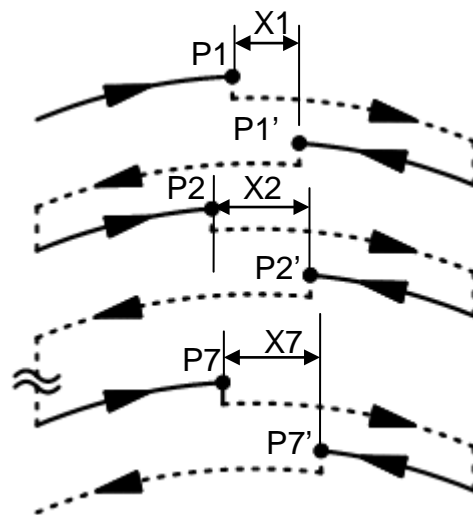

* P1~P7 : Stop position after forward rotation
P1'~P7' : Stop position after reverse rotation
X1~X7 : Difference between the stop positions after forward and reverse rotations

Reverse positional accuracy : $|X1+X2+ \dots +X7|/7$

1-9 Encoder specifications (Absolute encoder)

The absolute encoder used in the SHA series is a multi-turn magnetic absolute encoder. This encoder consists of 17 bit single turn absolute encoder and a 16 bit cumulative counter for detecting the number of total revolutions.

This encoder constantly monitors the absolute machine position and, by means of a backup battery, stores the position regardless of whether the driver or external controller power is turned ON or OFF. Accordingly, once the origin is detected when the machine is first installed, homing is not required for subsequent power ON operation. This facilitates an easy recovery after a power failure or machine breakdown.

Additionally, when the power is ON, the single revolution absolute position and the number of revolutions is calculated with dual-redundant systems and comparison checks are continually performed on the data. This highly reliable design allows for encoder errors to be self-detected should they ever occur.

In addition, a backup capacitor is installed in the encoder to retain the absolute position data even when the actuator is disconnected from the driver for the purpose of maintenance, etc. (Internal backup battery). It is recommended that you replace the backup battery in the HA-800 driver while the driver is receiving power.

Specifications

Type*1	Magnetic sensor/electronic battery backup type (Single rotation optic, multiple revolution magnetic sensor/electronic battery backup type)
Resolution per motor revolution	17 bits (2^{17} : 131,072 pulses)
Maximum cumulative motor shaft revolutions	16 bits (2^{16} : 65,536 revolutions cumulatively)
Maximum permissible motor shaft rotational speed	7000r/min
Safety/redundancy	<ul style="list-style-type: none"> • Check method in which two identical single revolution detectors are compared • Check method in which two identical cumulative revolution counters are compared
Backup time by external battery*2	1 year (when power is not supplied)
Backup time by internal battery	30 minutes (after 3 hours of charge, ambient temperature of 25°C, axis stopped) (For backup while the driver and encoder are disconnected briefly)

*1: Size 20 is equipped with an optical encoder; other models are equipped with a magnetic encoder.

*2: Battery box is sold separately (Recommended battery is Maxell ER 17/33 battery)

Resolution at the output shaft

Encoder resolution		2^{17} (131,072)					
Reduction ratio		11:1	51:1	81:1	101:1	121:1	161:1
Resolution at the output shaft	Pulse/rev	1,441,792	6,684,672	10,616,832	13,238,272	15,859,712	21,102,592
Resolvable angle per pulse (approximate)	Sec.	Approx. 0.9	Approx. 0.2	Approx. 0.12	Approx. 0.1	Approx. 0.082	Approx. 0.061
Reduction ratio		50:1	80:1	100:1	120:1	160:1	
Resolution at the output shaft	Pulse/rev	6,553,600	10,485,760	13,107,200	15,728,640	20,971,520	
Resolvable angle per pulse (approximate)	Sec	Approx. 0.2	Approx. 0.12	Approx. 0.1	Approx. 0.082	Approx. 0.062	

Absolute position data

[Absolute position] indicates the absolute position within one motor shaft revolution, while [multi revolution] indicates the number of motor revolutions. The position of the actuator output shaft is obtained by the following formula:

Position of actuator output shaft = (Absolute position + Multi revolution data x Encoder resolution) / Reduction ratio

Transfer of encoder data

Data is transferred via bi-directional communication in a normal condition while power is supplied. When the driver control power supply is turned OFF and the driver enters the battery backup mode, communication stops.

Output shaft single revolution absolute model (Option)

With the standard actuator, when it continues to rotate in just one direction, the absolute encoder eventually exceeds the number of revolutions that can be detected with multi-revolution detection and it becomes impossible to manage position information accurately.

With the output shaft single revolution absolute model, each time the output shaft turns through single revolution, the cumulative multi revolution counter is cleared to 0. This is how position information is accurately managed when the shaft continuously turns in just one direction.

1-10 Output Stiffness

Moment stiffness

The moment stiffness refers to the torsional stiffness when a moment load is applied to the output shaft of the actuator (shown in the figure).

For example, when a load is applied to the end of an arm attached on the output shaft of the actuator, the face of the output shaft of the actuator tilts in proportion to the moment load. The moment stiffness is expressed as the load/gradient angle.

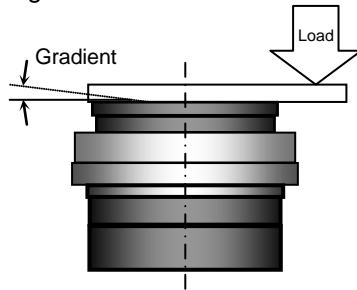

Model		SHA20A	SHA25A		SHA32A	
Item	Reduction ratio	50:1 or more	11:1	50: 1 or more	11:1	50:1 or more
Moment stiffness	Nm/rad	25.2×10^4	37.9×10^4	39.2×10^4	86.1×10^4	100×10^4
	kgf·m/rad	25.7×10^3	38.7×10^3	40×10^3	87.9×10^3	102×10^3
	kgf·m/arc-min	7.5	11.3	11.6	25.7	29.6

Model		SHA40A	SHA58A	SHA65A
Item	Reduction ratio	50:1 or more	80:1 or more	80:1 or more
Moment stiffness	Nm/rad	179×10^4	531×10^4	741×10^4
	kgf·m/rad	183×10^3	542×10^3	756×10^3
	kgf·m/arc-min	53.2	158	220



Do not apply torque, load or thrust to the sleeve (hollow shaft) directly.

The sleeve (hollow shaft) is adhered to the output rotary shaft. Accordingly, the adhered sleeve may be detached from the output rotary shaft if a torque or load is applied to the sleeve (hollow shaft).

Do not apply any torque, moment load or thrust load directly to the sleeve (hollow shaft).

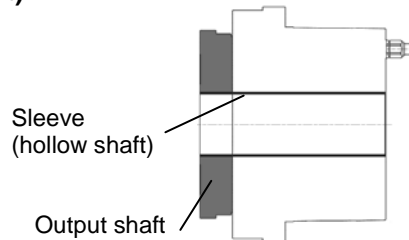

Torsional Stiffness

Caution

- The speed reducer uses (1) speed ratio 50 or more for the HarmonicDrive® gear and (2) speed ratio 11 for the HPF hollow planetary series. The structures of the speed reducers are different, so their rotation direction torsional stiffness are different. Refer to individual characteristics shown on the graphs and tables.

If a torque is applied to the output shaft of the actuator with the input locked, the output shaft will torsionally deflect roughly in proportion to the torque.

The upper right figure shows the torsional angle of the output shaft when a torque, starting from zero and increased to positive side [+T₀] and negative side [-T₀], is applied to the output shaft. This [torque vs. torsional angle] diagram, typically follows a loop of 0-A-B-A'-B'-A. The torsional stiffness of the SHA series actuator is expressed by the slope of this [torque vs. torsional angle] diagram representing a spring constant (unit: Nm/rad).

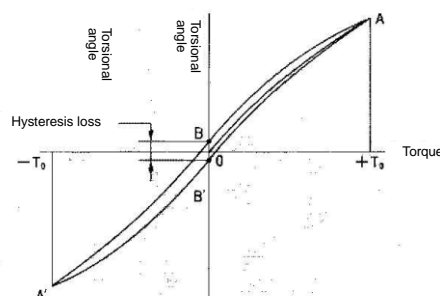

As shown by lower right figure, this [torque vs. torsional angle] diagram is divided into three regions and the spring constants in these regions are expressed by K₁, K₂, and K₃, respectively.

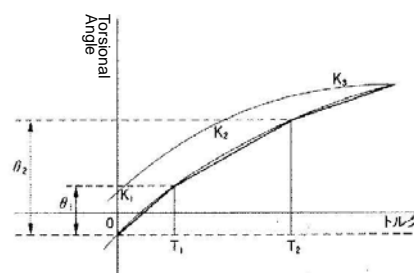

- K₁ : Spring constant for torque region 0 to T₁
- K₂ : Spring constant for torque region T₁ to T₂
- K₃ : Spring constant for torque region over T₂

The torsional angle for each region is expressed as follows:

- Range where torque T is T₁ or below: $\varphi = \frac{T}{K_1}$
- Range where torque T is T₁ to T₂: $\varphi = \theta_1 + \frac{T - T_1}{K_2}$
- Range where torque T is T₂ to T₃: $\varphi = \theta_2 + \frac{T - T_2}{K_3}$

* φ : Torsional angle

The table below shows the averages of T₁ to T₃, K₁ to K₃, and θ_1 to θ_2 for each actuator.

Model	SHA20A		SHA25A		SHA32A		SHA40A	
	50:1 51:1	80:1 or more	50:1 51:1	80:1 or more	50:1 51:1	80:1 or more	50:1 51:1	80:1 or more
T1	7.0		14		29		54	
	0.7		1.4		3.0		5.5	
K1	1.3	1.6	2.5	3.1	5.4	6.7	10	13
	0.38	0.47	0.74	0.92	1.6	2.0	3.0	3.8
θ_1	5.2	4.4	5.5	4.4	5.5	4.4	5.2	4.1
	1.8	1.5	1.9	1.5	1.9	1.5	1.8	1.4
T2	25		48		108		196	
	2.5		4.9		11		20	
K2	1.8	2.5	3.4	5.0	7.8	11	14	20
	0.52	0.75	1.0	1.5	2.3	3.2	4.2	6.0
θ_2	15.4	11.3	15.7	11.1	15.7	11.6	15.4	11.1
	5.3	3.9	5.4	3.8	5.4	4.0	5.3	3.8
K3	2.3	2.9	4.4	5.7	9.8	12	18	23
	0.67	0.85	1.3	1.7	2.9	3.7	5.3	6.8

Model	SHA58A	SHA65A
Reduction ratio	81:1 or more	81:1 or more
T1		
Nm	168	235
kgf·m	17	24
K1		
x10 ⁴ Nm/rad	40	54
kgf·m/arc min	12	16
θ 1		
x10 ⁻⁴ rad	4.1	4.4
arc min	1.4	1.5
T2		
Nm	598	843
kgf·m	61	86
K2		
X10 ⁴ Nm/rad	61	88
kgf·m/arc min	18	26
θ 2		
x10 ⁻⁴ rad	11.1	11.3
arc min	3.8	3.9
K3		
x10 ³ Nm/rad	71	98
kgf·m/arc min	21	29

The table below shows reference torque values calculated for different torsional angle.

(Unit: N·m)

Model	SHA20A		SHA25A		SHA32A		SHA40A	
Reduction ratio	50:1 51:1	80:1 or more	50:1 51:1	80:1 or more	50:1 51:1	80:1 or more	50:1 51:1	80:1 or more
2 arc min	8	11	15	21	31	45	63	88
4 arc min	19	25	35	51	77	108	144	208
6 arc min	30	43	56	84	125	178	233	342

Model	SHA58A	SHA65A
Reduction ratio	81:1 or more	81:1 or more
2 arc min	273	360
4 arc min	636	876
6 arc min	1050	1450

Torsional Stiffness (Ratio 11: HPF)

If a torque is applied to the output shaft of the actuator with the input locked, the output shaft will torsionally deflect roughly in proportion to the torque. When the values for torque are gradually changed in sequence from (1) Rated output torque in the positive rotation direction→(2) zero→(3) Rated output torque in the negative rotation direction→(4) zero→(5) Rated output torque in the positive rotation direction, the values follow a loop (1)→(2)→(3)→(4)→(5) (returns to (1)) shown in Fig.1 [torque vs. torsional angle diagram].

The gradient of the region [Rated output torque] from [0.15 x rated output torque] is small, and the torsional stiffness of the HPF series is the average of this gradient. The gradient of the region [0.15 x rated output torque] from [zero torque] is large. This gradient is caused by semi-partial contact in the meshing region and uneven load distribution from light loads and so forth on the planet gears.

An explanation is provided below on how to calculate the total torsional quantity on one side from a no-load state after a load has been applied by the speed reducer.

$$\theta = D + \frac{T - TL}{A/B}$$

θ : total torsional quantity

D: torsional quantity on one side given by rated output torque x 0.15 torque

T: load torque

TL: rated output torque x 0.15 torque (= $T_R \times 0.15$)

A/B: torsional stiffness

The zero torque part widths of (2) and (4) in the figure on the right [torque vs. torsional angle diagram] is called the hysteresis loss. For the HPF series, backlash is defined as hysteresis loss [rated output torque in the negative rotation direction] from [rated output torque in the positive rotation direction]. The HPF series has a backlash of less than 3 minutes (less than 1 minute with special products) with factory settings.

Item	Model • speed ratio	SHA25A	SHA32A
		11	11
Backlash	arc-min	3	3
	10^{-4} rad	8.7	8.7
Rated torque (T_R)	Nm	21	44
Torsional quantity on one side given by $T_R \times 0.15$ (D)	arc-min	2.0	1.7
	10^{-4} rad	5.8	4.9
Torsional stiffness (A/B)	kgf·m/arc-min	1.7	3.5
	$\times 10^{-4}$ Nm/rad	5.70	11.7

Fig. 1 Torque vs. torsional angle diagram

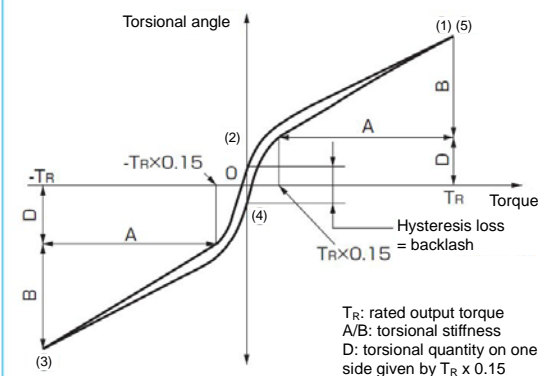

1-11 Direction of rotation

SG/HP

As a default, Forward rotation direction of the actuator is defined as counterclockwise (CCW) rotation as viewed from the load shaft when a Forward command (FWD command pulse) is given to a SHA series actuator from a HA-800 driver

This rotation direction can be changed on the HA-800 driver by selecting [SP50: Command polarity setting] under [System parameter mode 3].

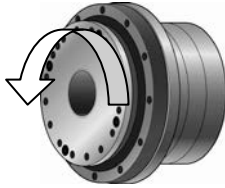

Counterclockwise rotation direction

Setting of [SP50: Command polarity setting]

Set value	FWD command pulse	REV command pulse	Setting
0	CCW (counterclockwise) direction	CW (clockwise) direction	Default
1	CW (clockwise) direction	CCW (counterclockwise) direction	

CG

As a default, the rotation direction is defined as clockwise (CW) rotation as viewed from the output shaft when a FWD command pulse is given from a HA-800 driver.

This rotation direction can be changed on the HA-800 driver by selecting [SP50: Command polarity setting] under [System parameter mode 3].

Setting of [SP50: Command polarity setting]

Set value	FWD command pulse	REV command pulse	Setting
0	CW (clockwise) direction	CCW (counterclockwise) direction	Default
1	CCW (counterclockwise) direction	CW (clockwise) direction	

1-12 Shock resistance

The actuator can withstand a 300 m/s^2 shock in all directions (up/down, left/right, and front/rear):

Impact acceleration: 300 m/s^2

In our shock resistance test, the actuator is tested 3 times in each direction. Actuator operation is not guaranteed in applications where impact exceeding the above value is constantly applied.

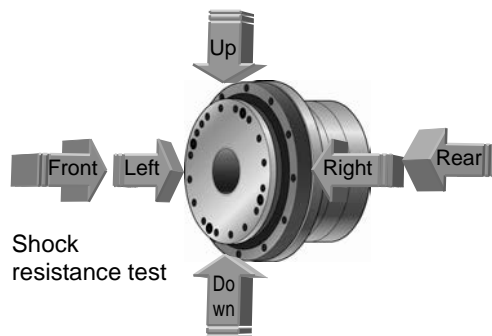

1-13 Vibration resistance

The actuator can withstand a 25 m/s^2 vibration acceleration (frequency 10 to 400 Hz) in all directions (up/down, left/right, and front/rear):

Vibration acceleration: 25 m/s^2 (frequency: 10 to 400Hz)

In our test, the actuator is tested for 2 hours in each direction at a vibration frequency sweep period of 10 minutes.

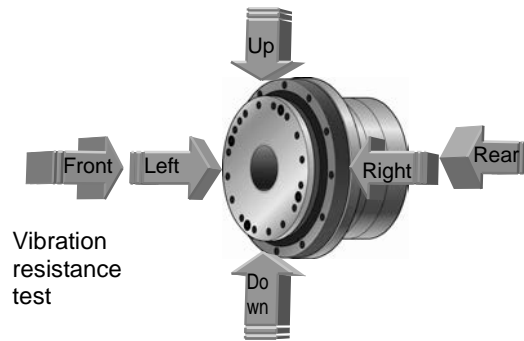

1-14 Operable range

The graph on the next page indicates the torque/speed operating range for the SHA actuators (combined with a HA-800 driver) is selected. For details, refer to [Chapter 2 SHA series selection].

1. Continuous motion range

The range allows continuous operation of the actuator.

2. 50% duty range

range indicates the torque/speed where 50% duty cycle operation is permitted (the ratio of operating time and idle time is 50:50).

Limit the operation cycle to a period of several minutes, and keep it within a range where the overload alarm of the driver does not sound.

3. Acceleration and deceleration range

This range indicates the torque/speed which the actuator can be operated momentarily. The range allows instantaneous operation like acceleration and deceleration.

The continuous and 50% duty motion ranges in each graph are measured when the actuator is mounted to an aluminum heatsink as specified in the graph.

Caution

- When the SHA SG is operated at a constant speed (motor shaft speed of 1,000 rpm or less) in the same direction under a constant load torque in a condition where the output shaft is facing up (output shaft is facing down with CG type), improper lubrication of the built-in speed reducer may cause abnormal sound or wear, leading to a shorter life. Improper lubrication can be prevented by changing the speed in the operation pattern, such as by periodically stopping the actuator. However, the planetary speed reducer (11:1) is not included.

SG type
SHA20A

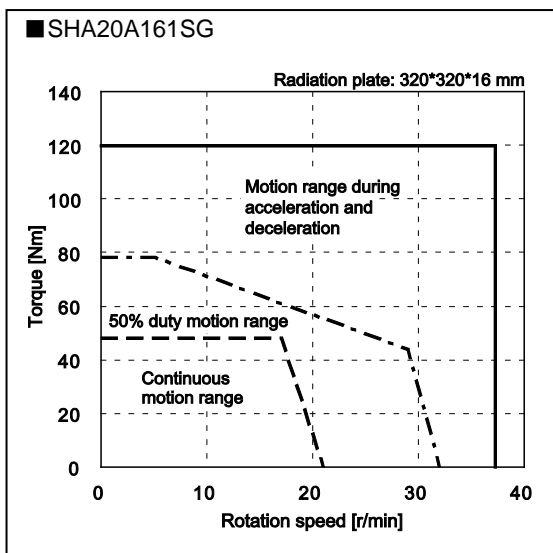
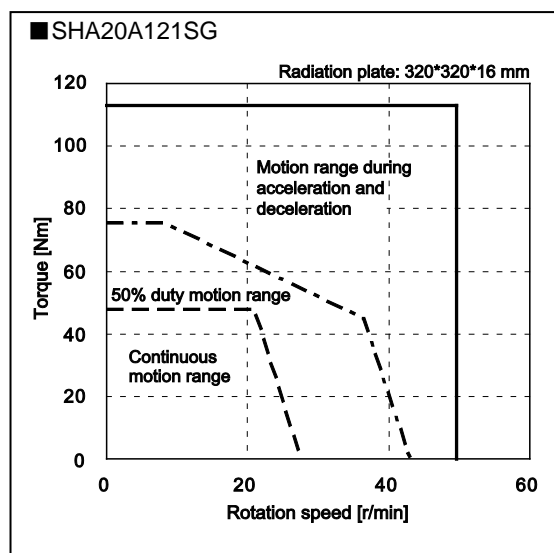
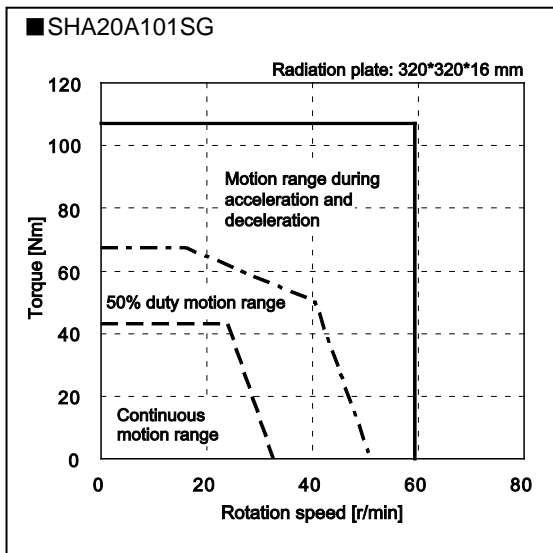
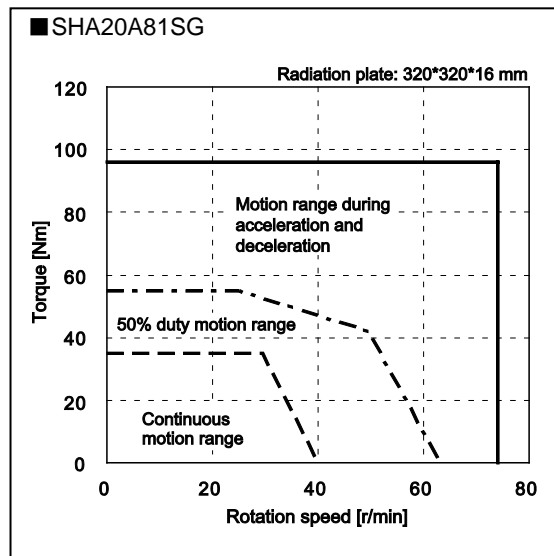
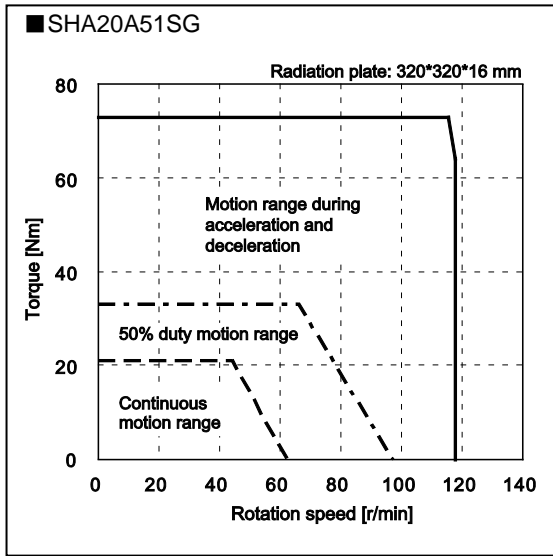

SG type
SHA25A (Specifications for motor input voltage of 100V)

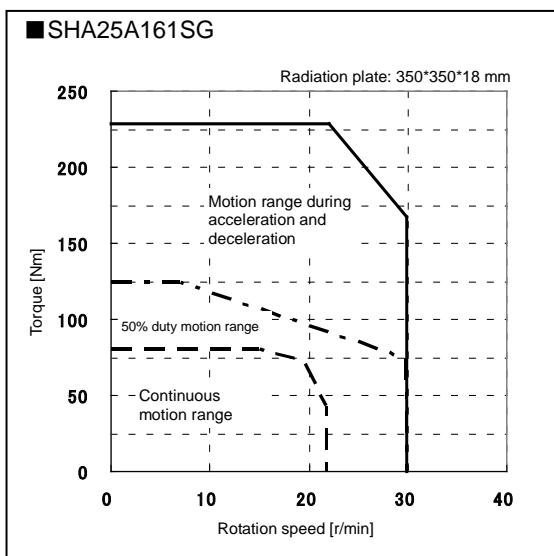
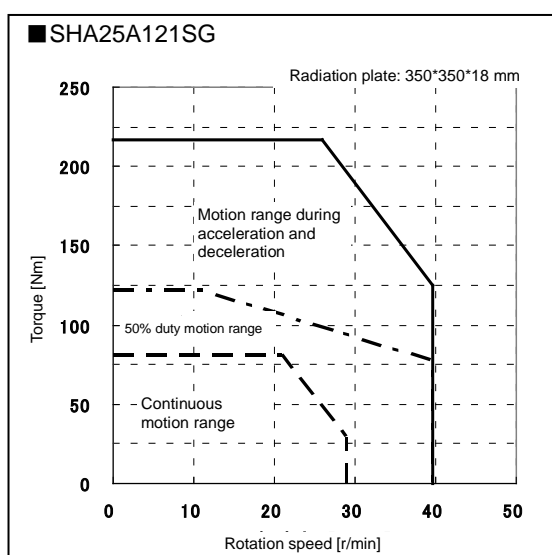
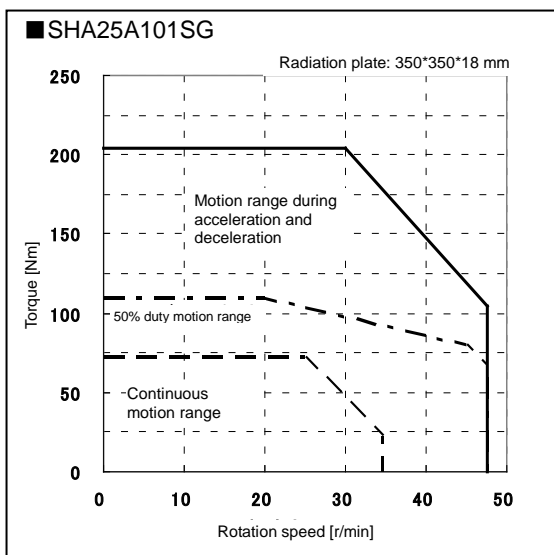
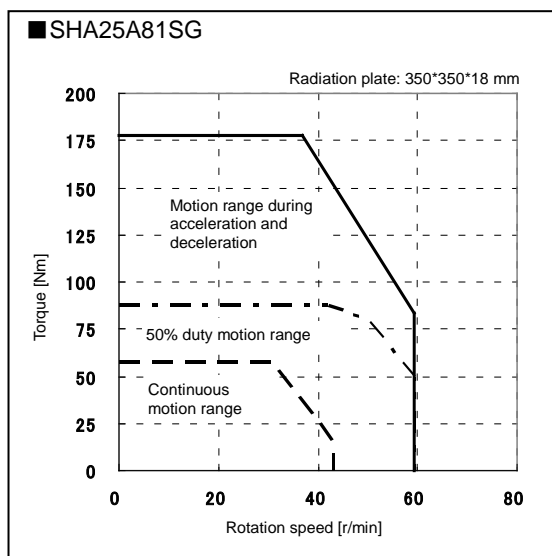
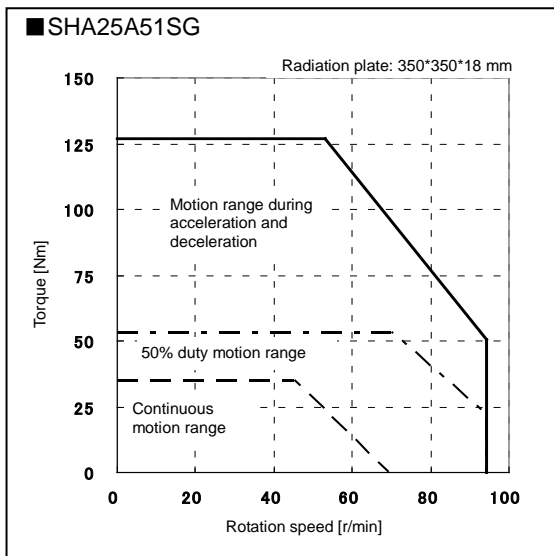

SG/HP type

SHA25A (Specifications for motor input voltage of 200V)

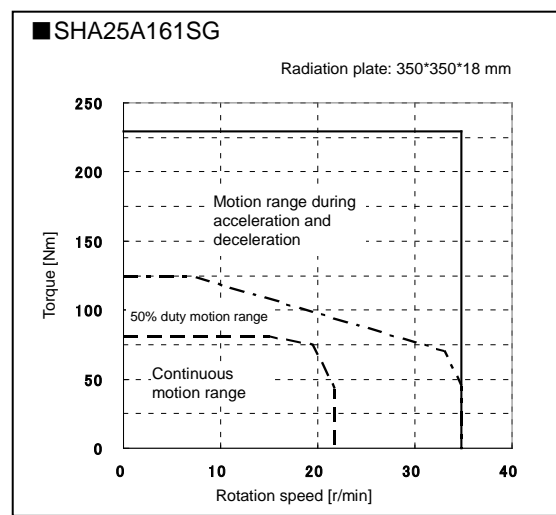
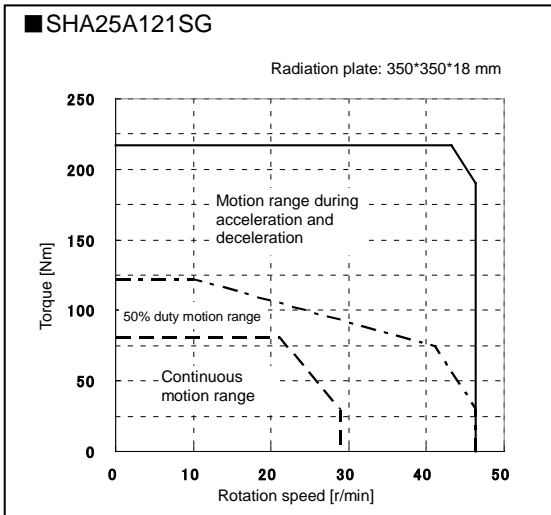
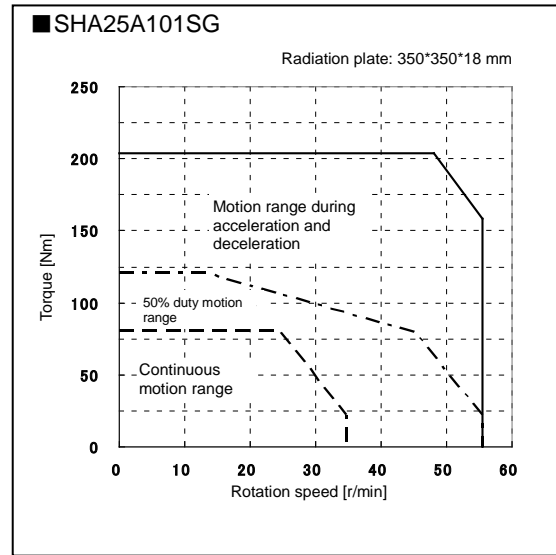
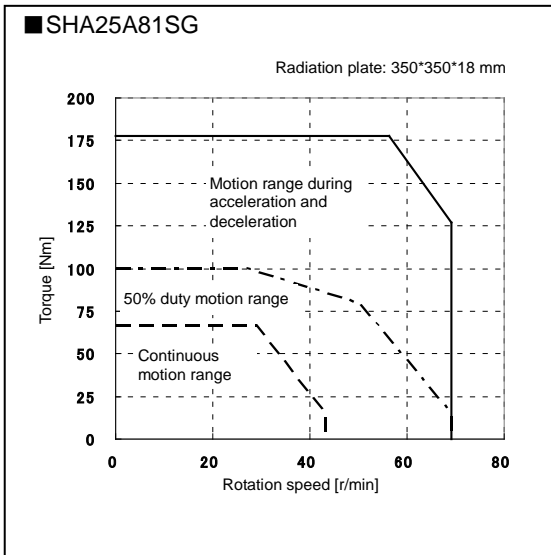
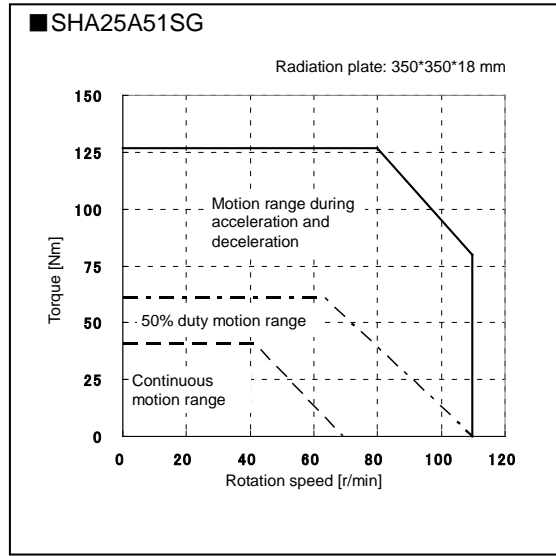
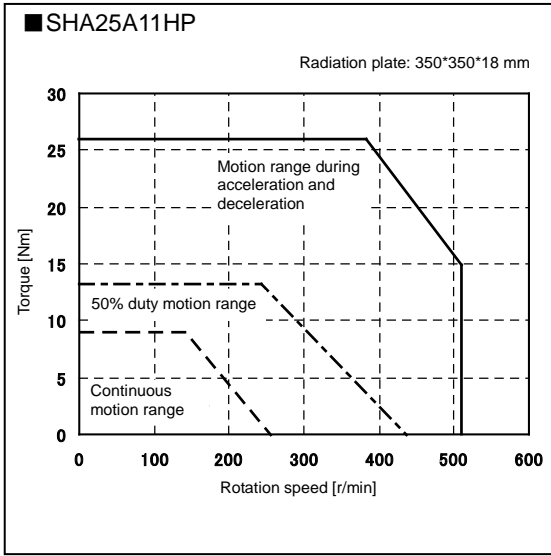

**SG/HP type
SHA32A**

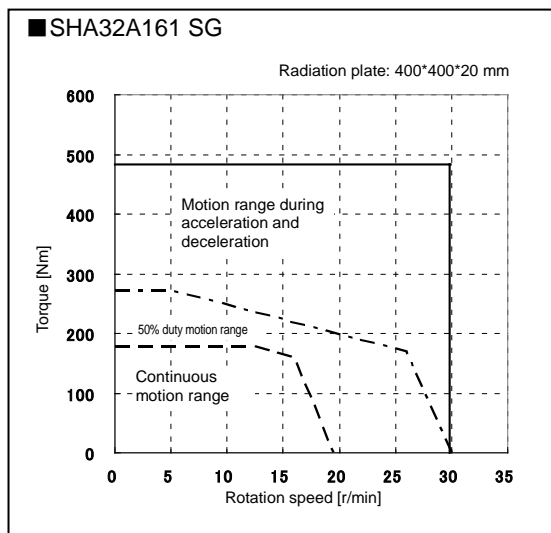
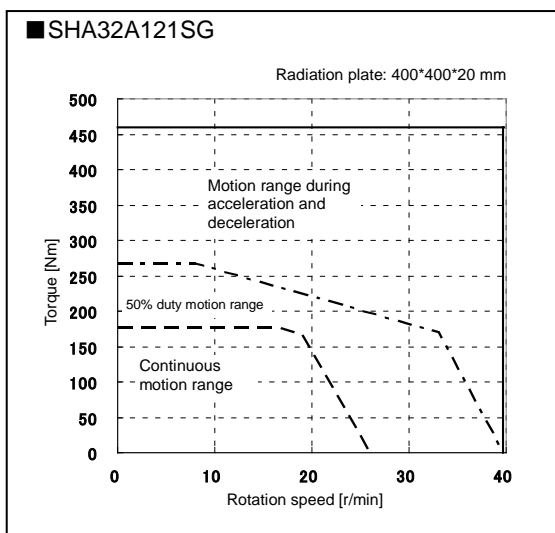
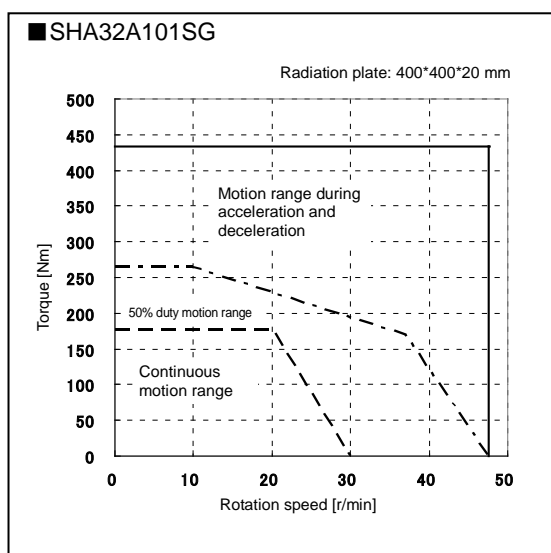
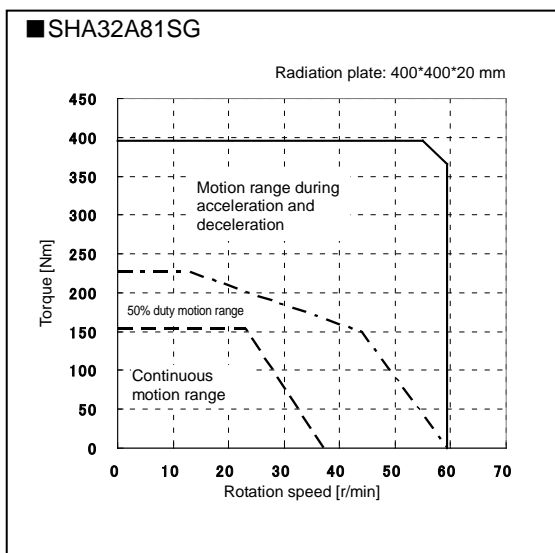
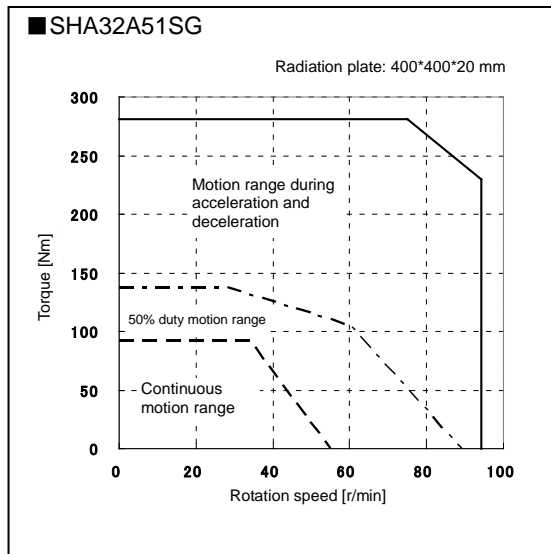
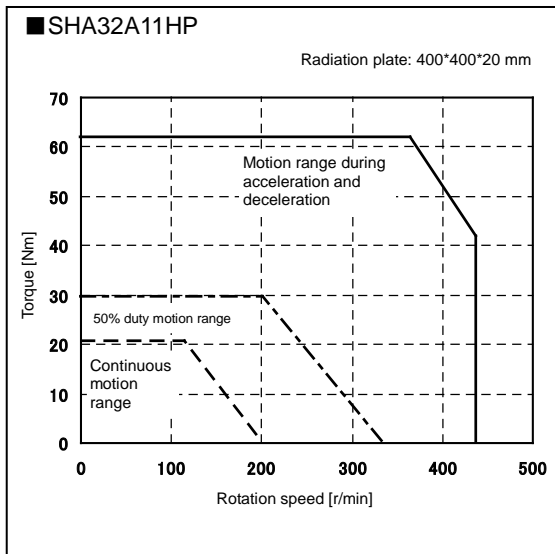

SG type
SHA40A

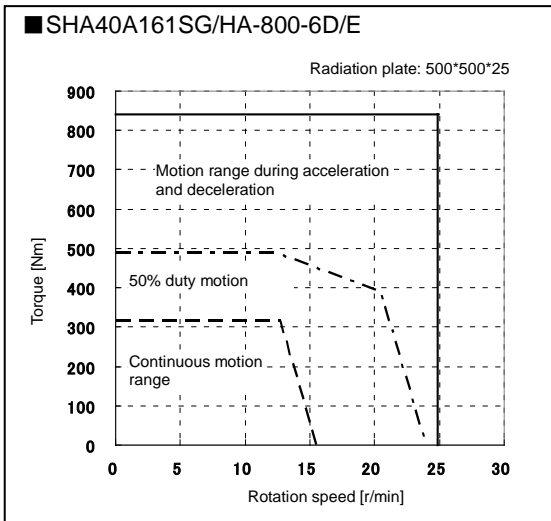
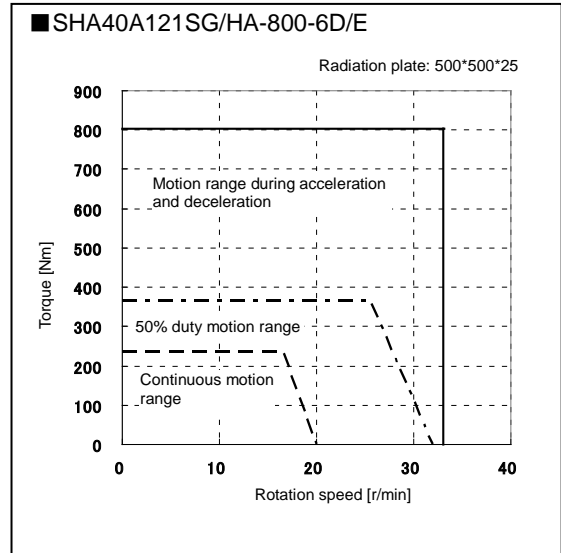
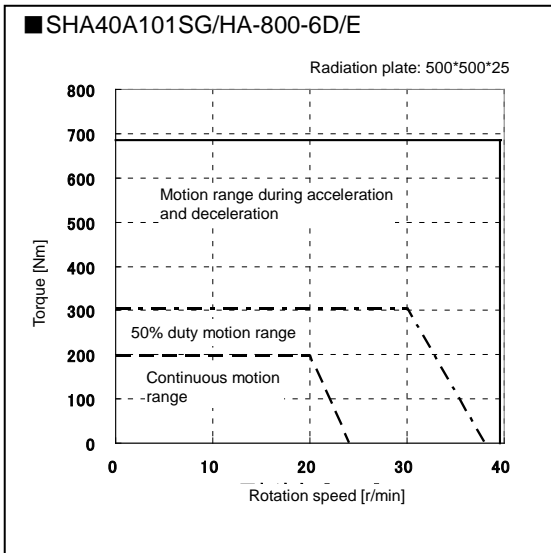
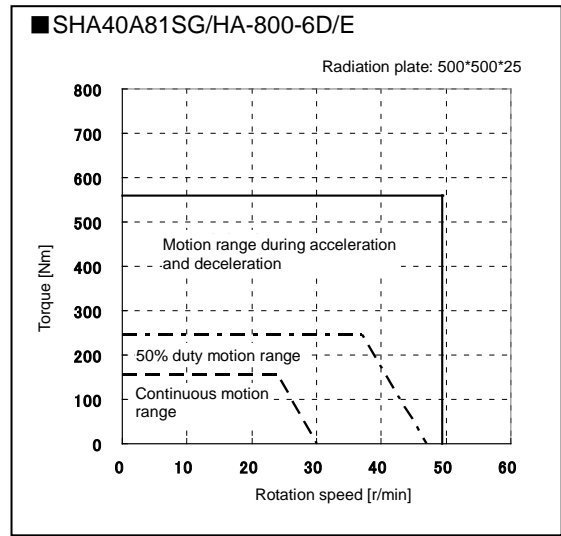
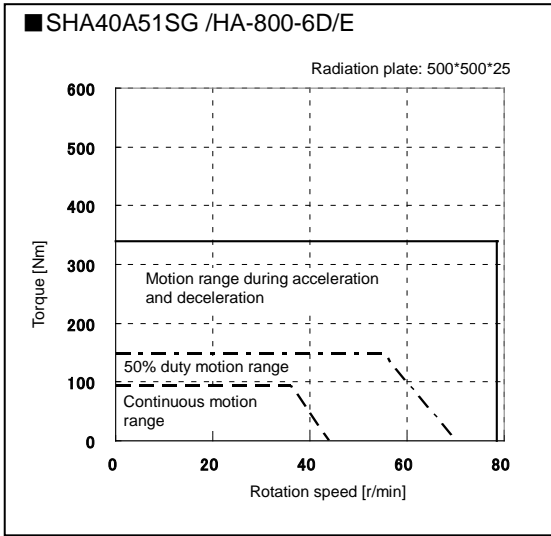

SG type

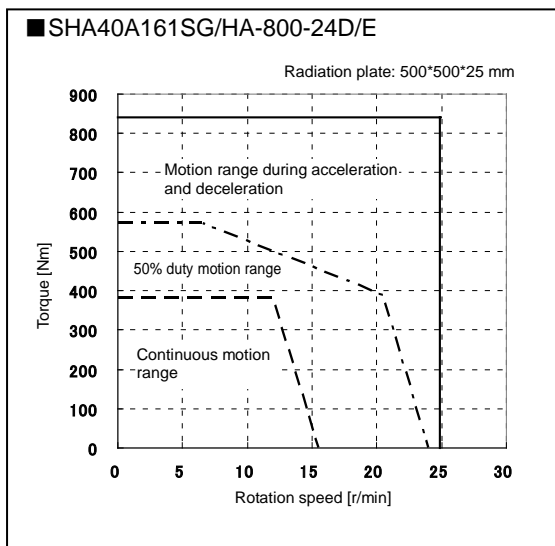
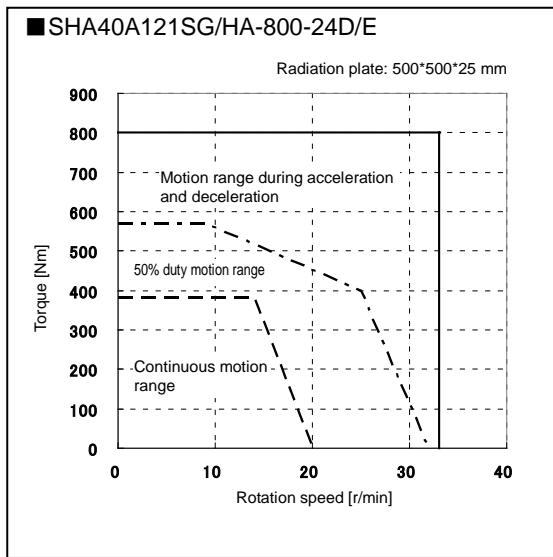
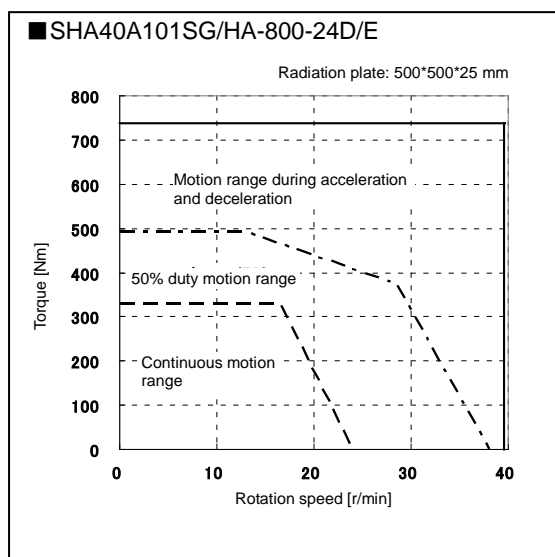
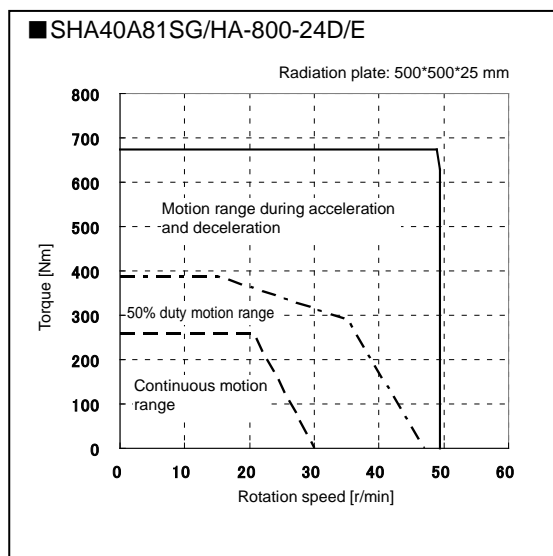
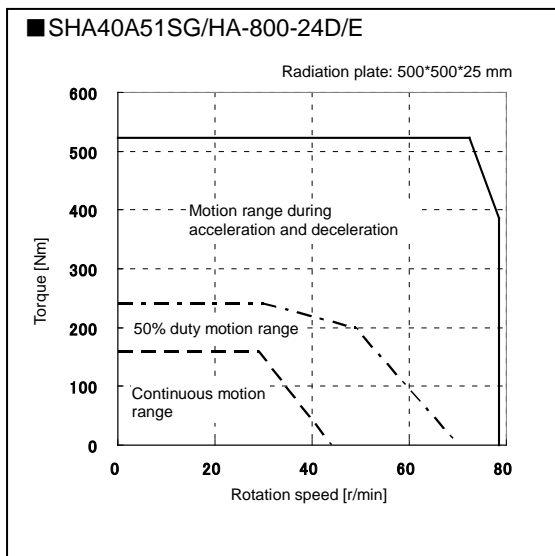

**SG type
SHA58A**

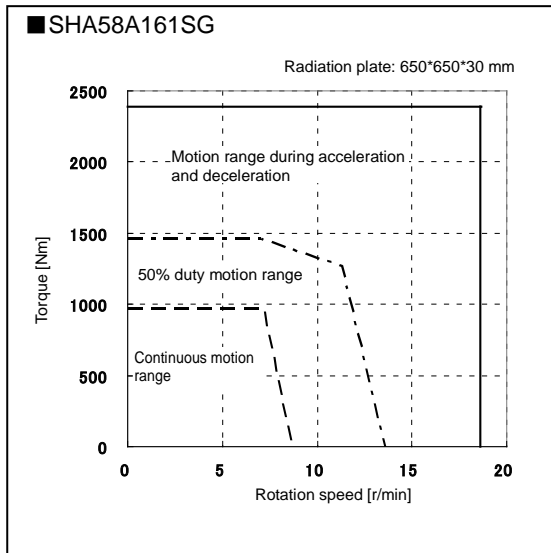
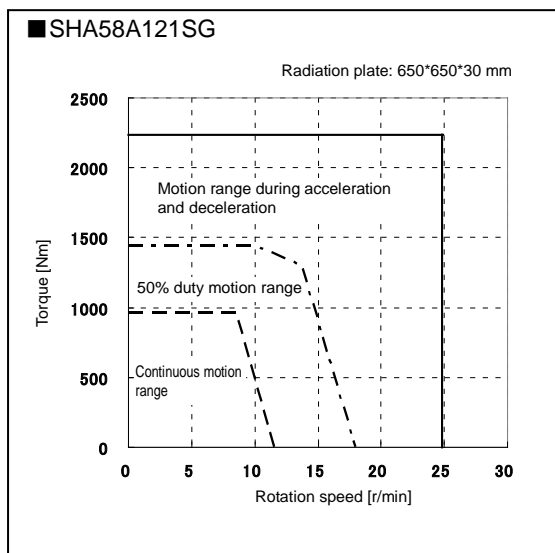
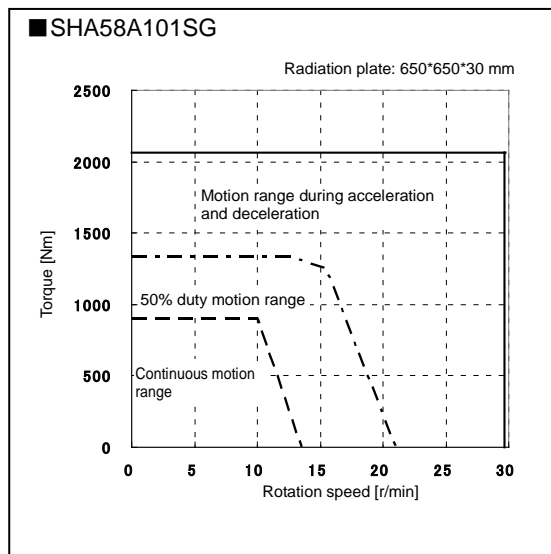
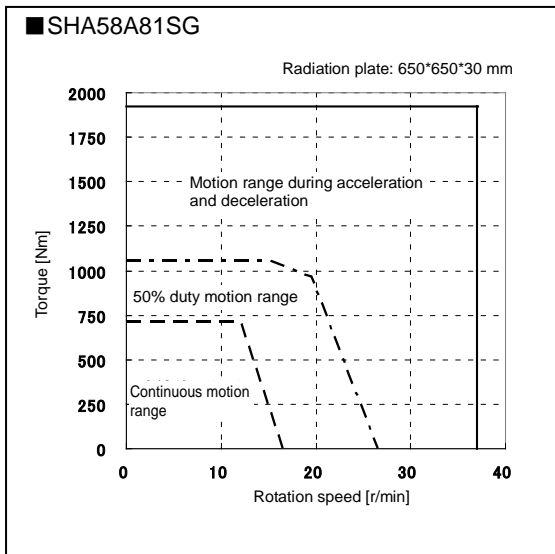

**SG type
SHA65A**

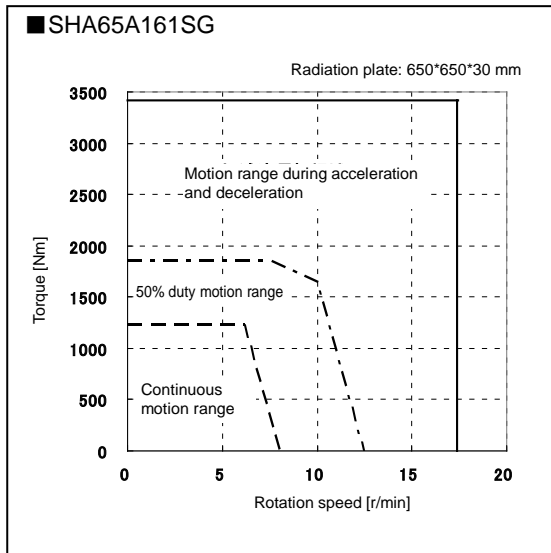
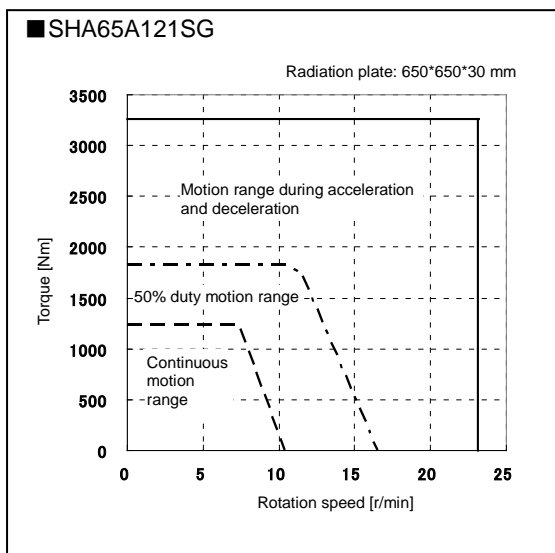
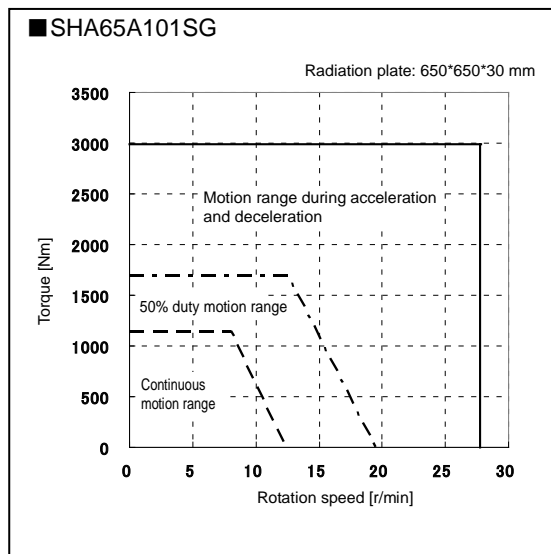
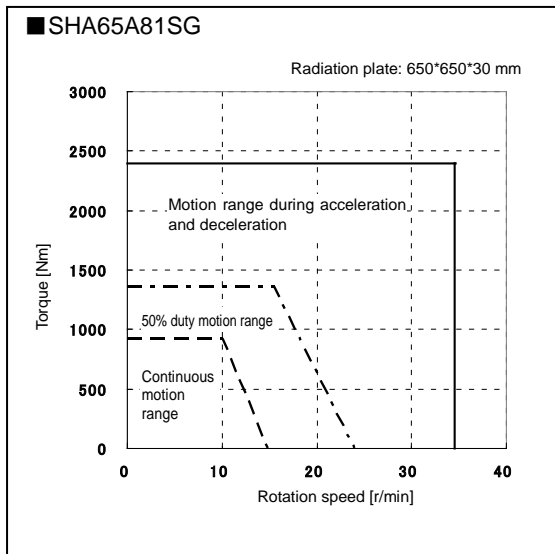

**CG type
SHA20A**

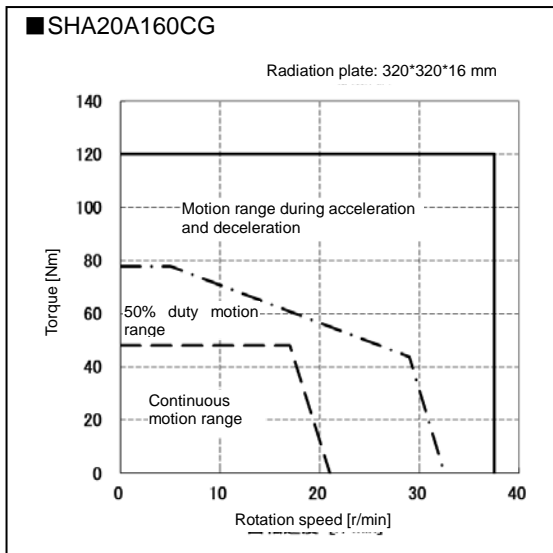
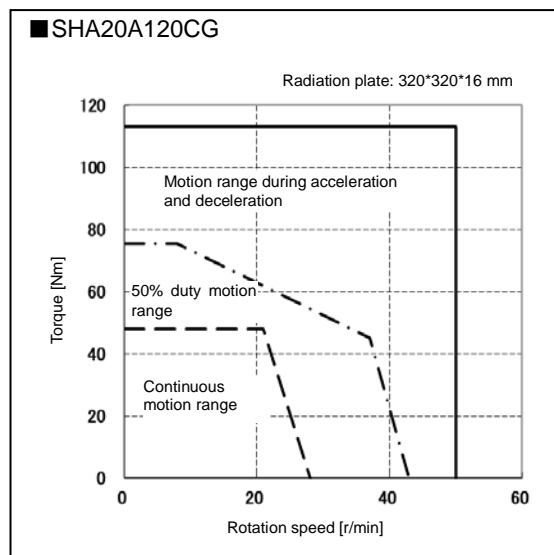
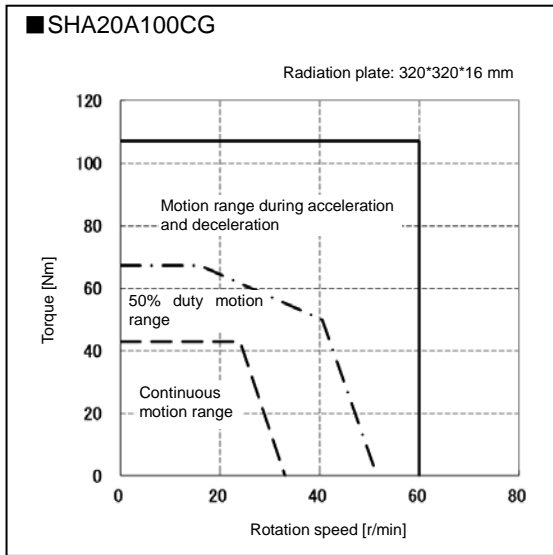
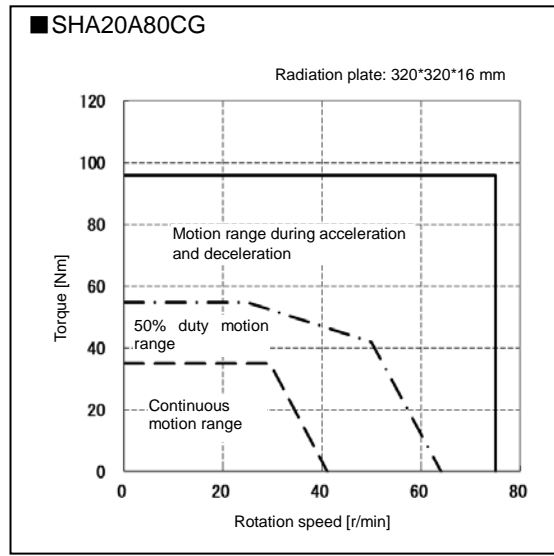
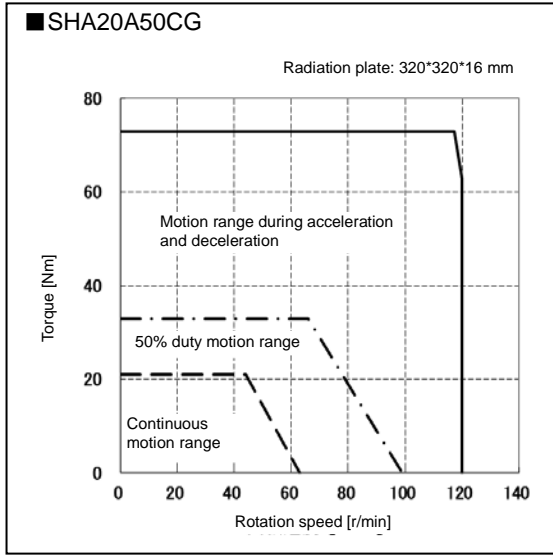

CG type
SHA25A (Motor input voltage 100V)

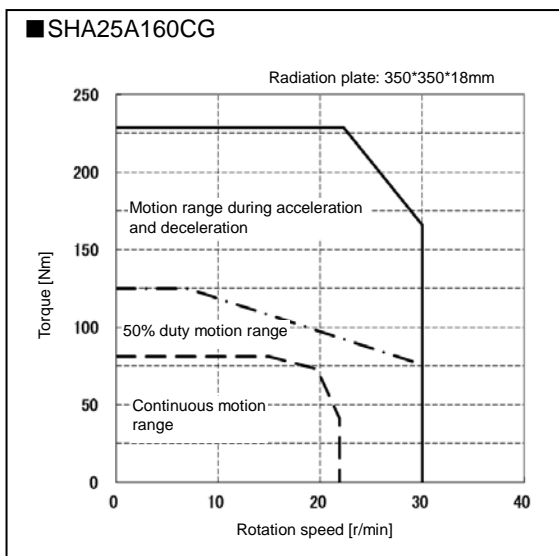
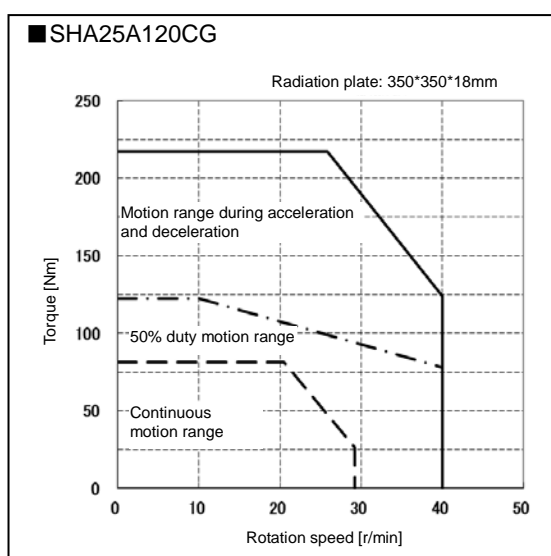
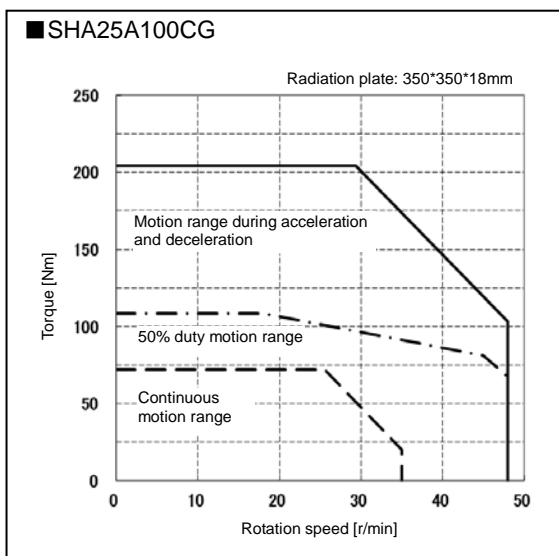
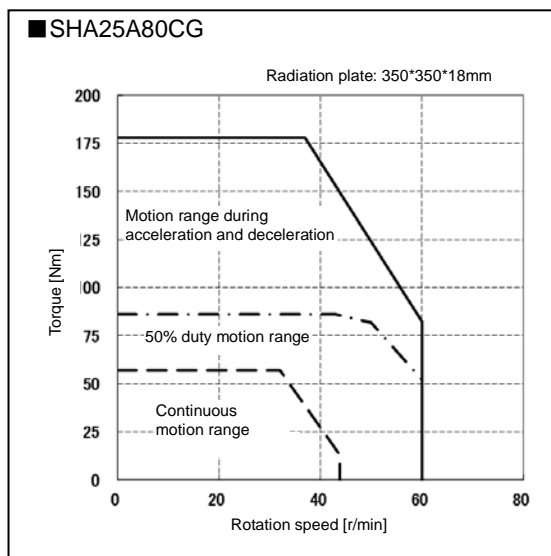
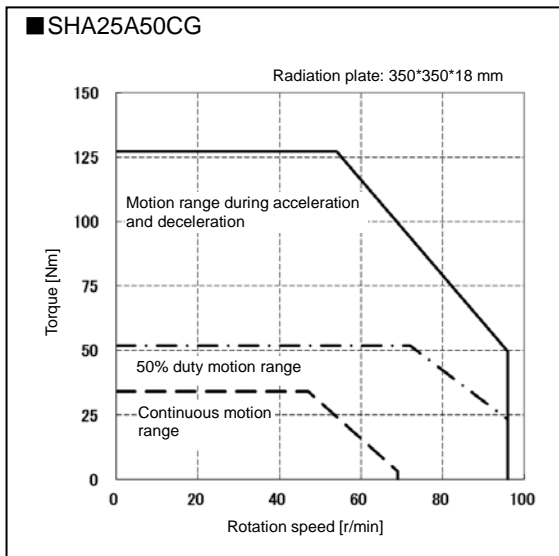

CG type
SHA25A (Motor input voltage 200V)

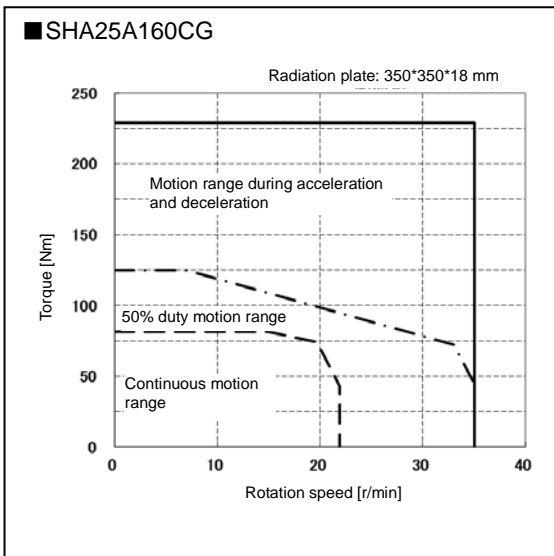
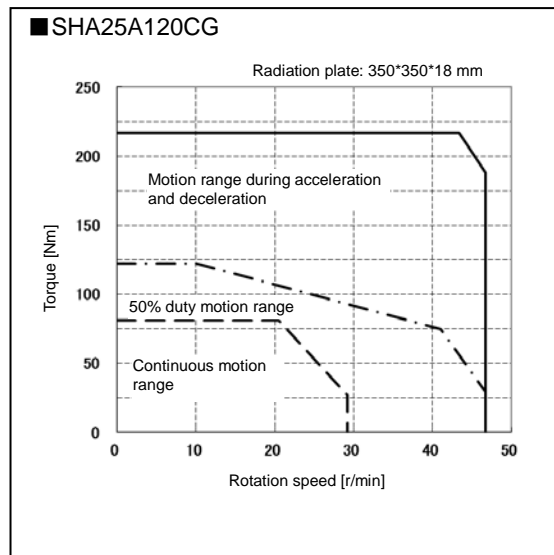
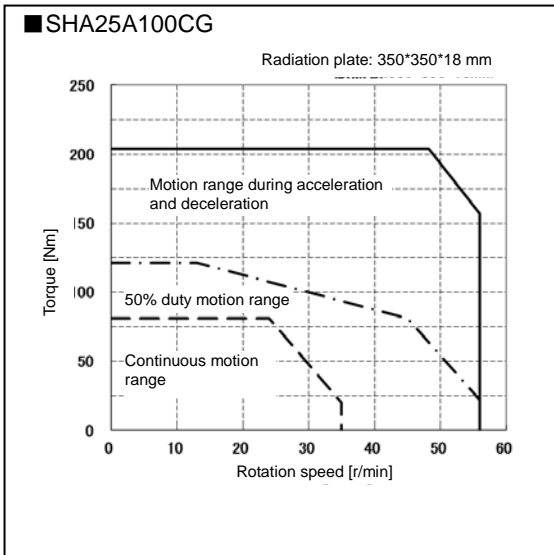
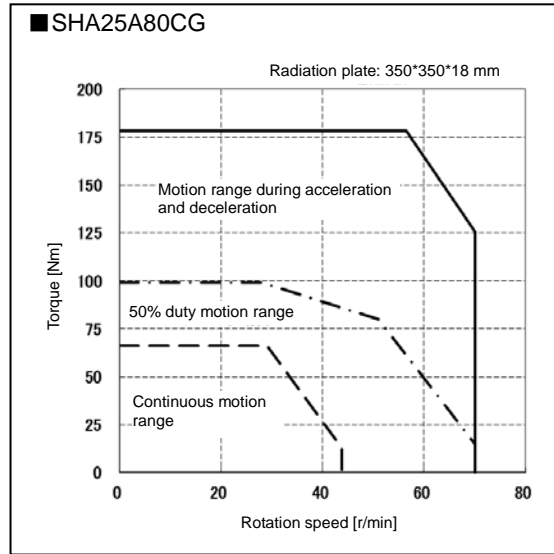
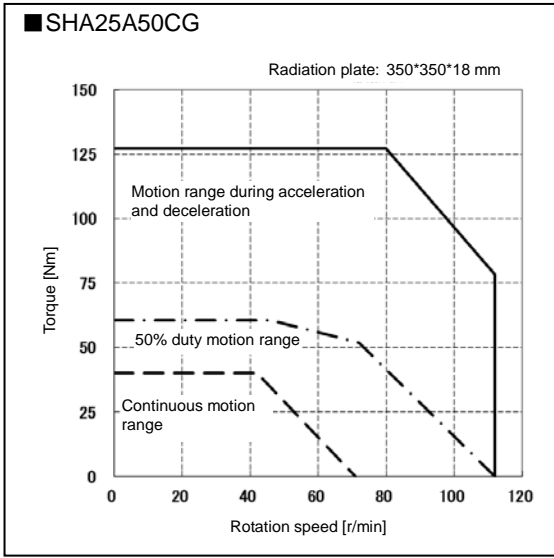

**CG type
SHA32A**

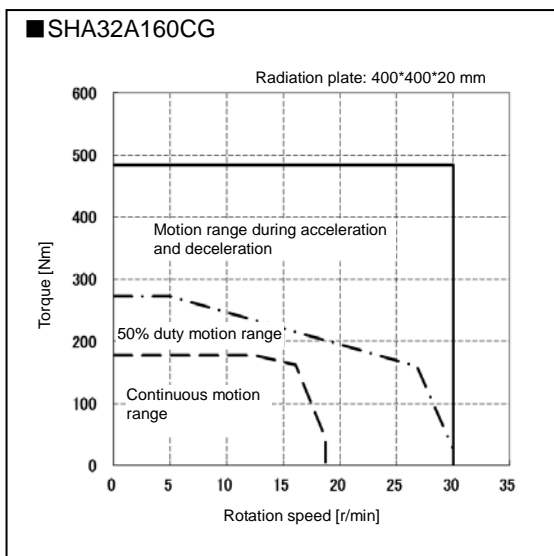
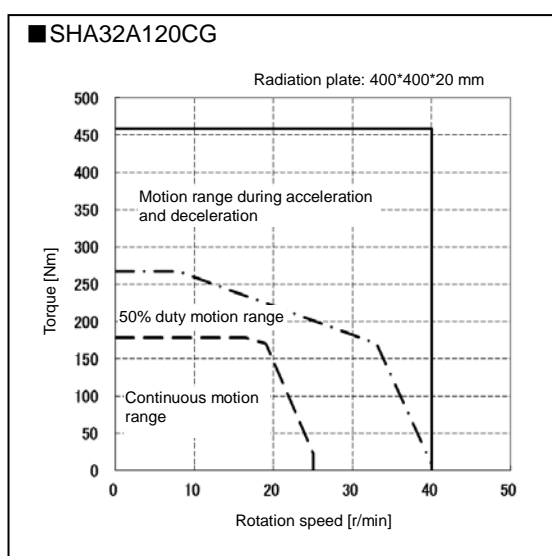
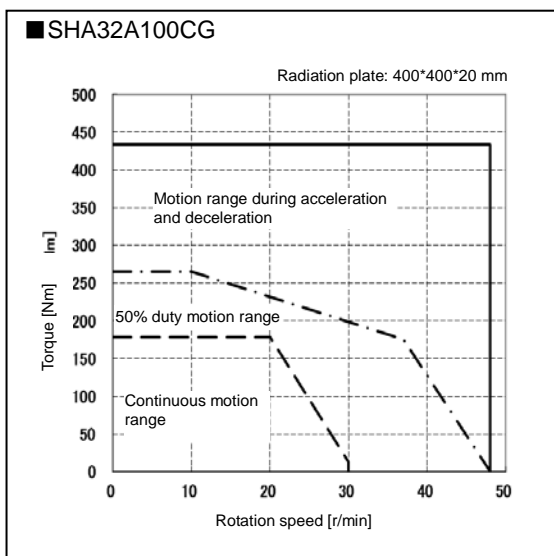
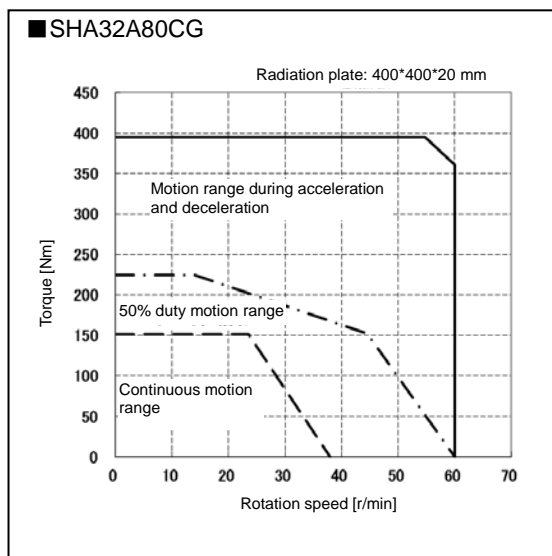
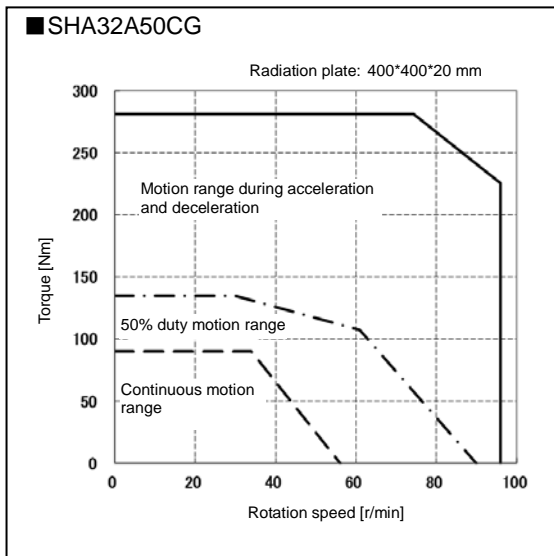

**CG type
SHA40A**

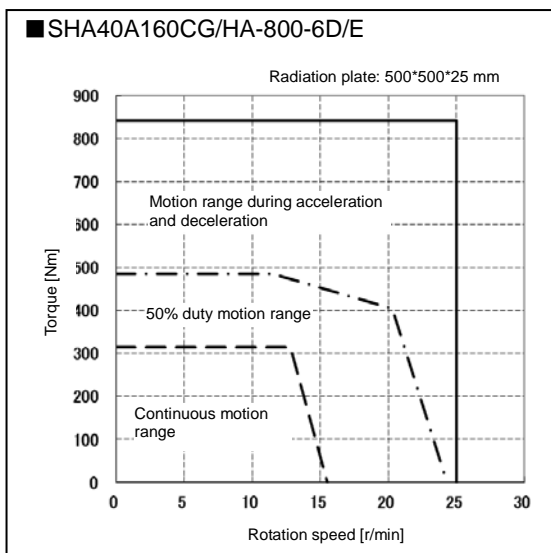
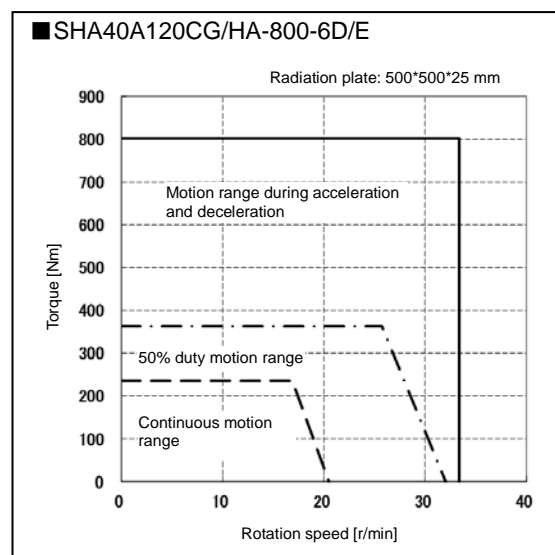
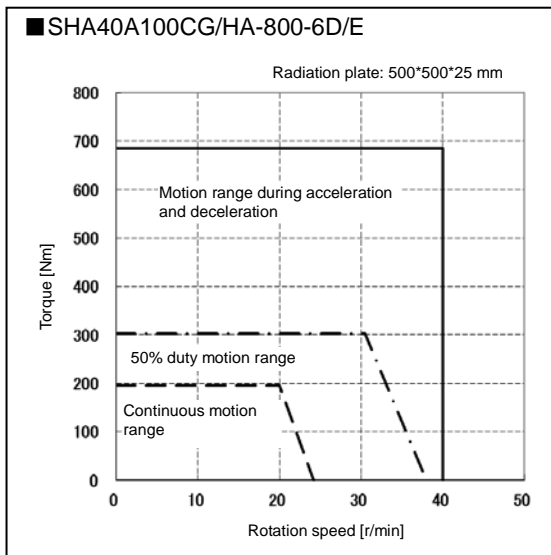
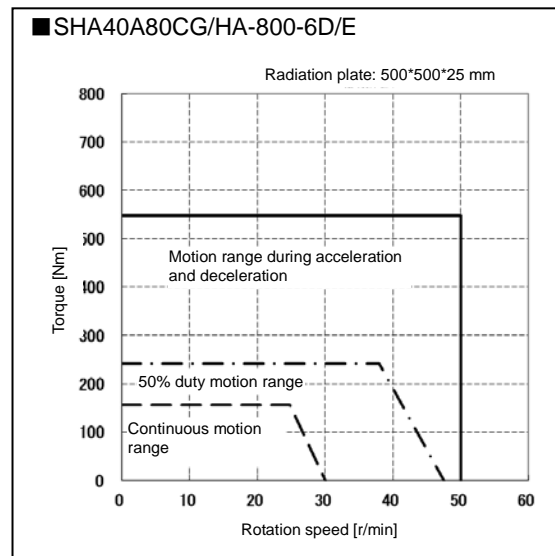
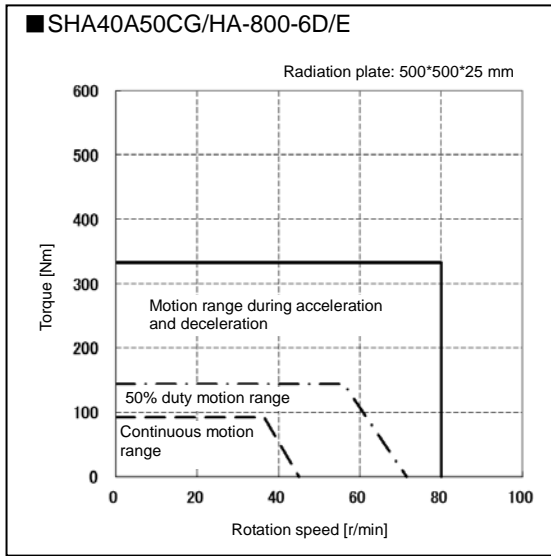

**CG type
SHA40A**

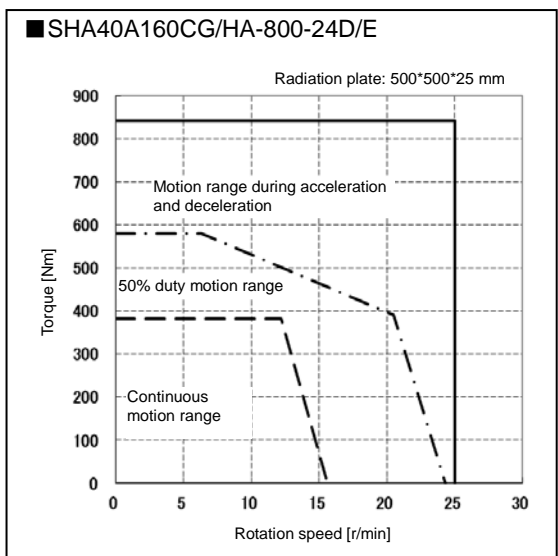
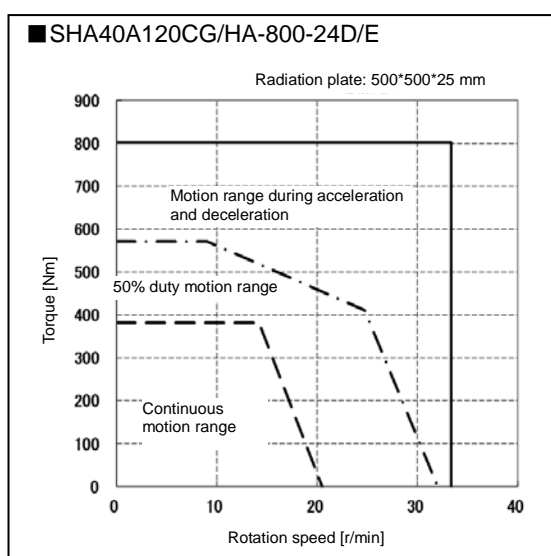
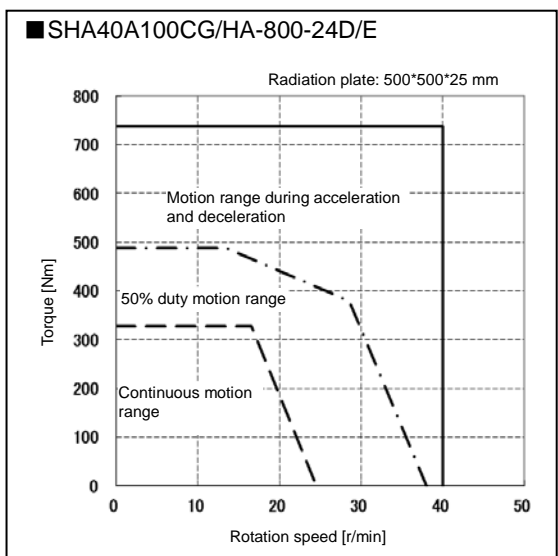
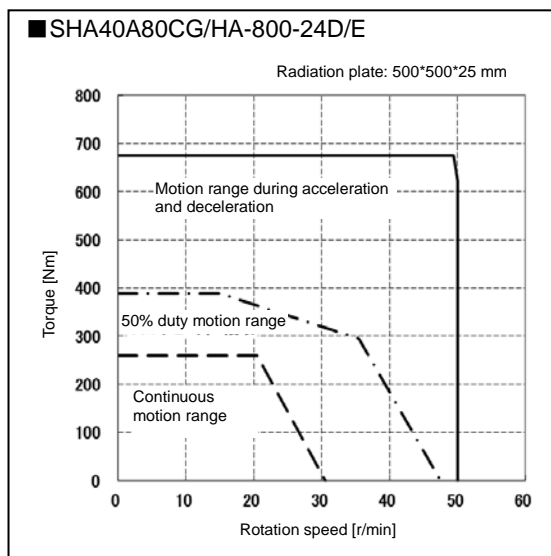
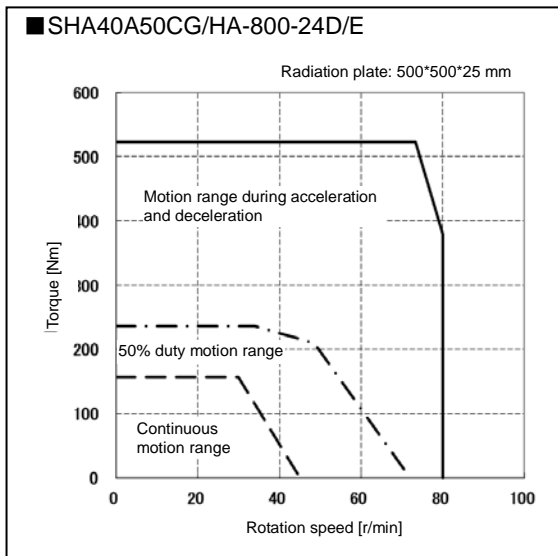

1-15 Cable specifications

The following tables show specifications of the motor and encoder cables of the SHA series actuators.

Motor cable specifications

- Size 20, 25, 32, 40

Pin number	Color	Name	
		Without brake	With brake
1	Red	Motor phase-U	Motor phase-U
2	White	Motor phase-V	Motor phase-V
3	Black	Motor phase-W	Motor phase-W
4	Green/yellow	PE	PE
5	Blue	No connection	Brake
6	Yellow	No connection	Brake

- Connector pin layout

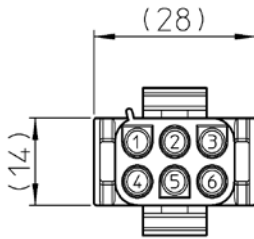

Connector model: 350715-1
Pin model:

	Model Nos 20, 25	Model Nos 32, 40
Motor UVW	350690-1	350547-1
Brake	350690-1	350690-1
Motor PE	350669-1	350669-1

by AMP

- Size 58, 65

Pin number	Name		Color (Extension cables)
	Without brake	With brake	
A	No connection	Brake	Blue
B	No connection	Brake	Yellow
C	No connection	No connection	—
D	Motor phase-U	Motor phase-U	Red
E	Motor phase-V	Motor phase-V	White
F	Motor phase-W	Motor phase-W	Black
G	PE	PE	Green/yellow
H	PE	PE	—
I	No connection	No connection	—

- Connector pin layout

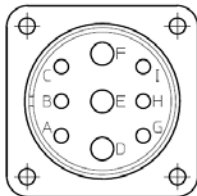

Connector model: CE05-2A24-11PGHS-D (by DDK)

Encoder cable specifications

- Size 20, 25, 32, 40

Pin number	Color	Signal name	Remarks
1A	Red	Vcc	Power supply input +5V
1B	Black	GND(Vcc)	Power supply input 0V (GND)
2A	Yellow	SD+	Serial signal differential output (+)
2B	Blue	SD-	Serial signal differential output (-)
3A	—	No connection	—
3B	Shield	FG	
4A	Orange	Vbat	Battery +
4B	Gray	GND(bat)	Battery - (GND)

- Connector pin layout

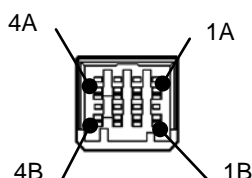

Connector model: 1-1903130-4
Pin model: 1903111-2, 1903116-2 or 1903117-2
by AMP

- Size 58, 65

Pin number	Signal name	Remarks
1	Vbat	Battery +
2	GND(bat)	Battery - (GND)
3	No connection	
4	Vcc	Power supply input +5V
5	GND(Vcc)	Power supply input 0V (GND)
6	No connection	
7	No connection	
8	SD+	Serial signal differential output (+)
9	SD-	Serial signal differential output (-)
10	FG	

- Connector pin layout

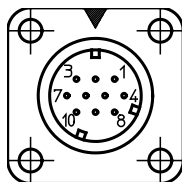

Connector model: CM10-R10P (D3)-01 (by DDK)

Chapter 2

Selection guidelines

This chapter explains how to select the right SHA series actuator.

2-1	SHA series selection.....	2-1
2-2	Change in load inertia moment	2-6
2-3	Verifying and examining load weights	2-7
2-4	Examining operating status	2-11

2-1 SHA series selection

2

Allowable load moment of inertia

To achieve high accuracy and performance, select a SHA series actuator where the allowable load moment of inertia for the actuator is not exceeded.

Note: The recommended values in the graphs below should be followed if you wish to shorten the transient vibration period during positioning moves or operate the actuator at a constant speed in a stable manner.

It is possible to operate the actuator when exceeding the allowable value if the actuator is accelerated and decelerated gradually, commands given from the host to the servo driver are adjusted, or the servo driver's vibration suppression function is used.

Refer to [A-2 Calculating inertia moment] (P5-3) for the calculation of inertia moment.

SG type

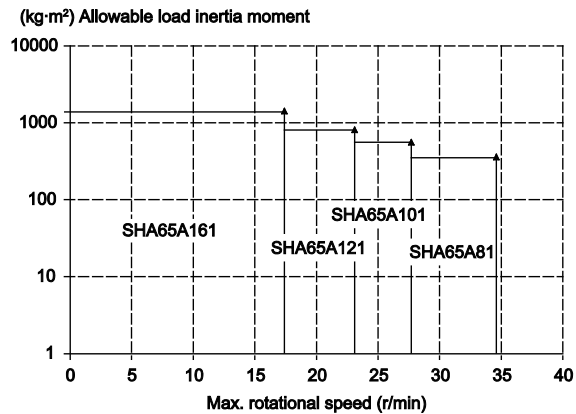
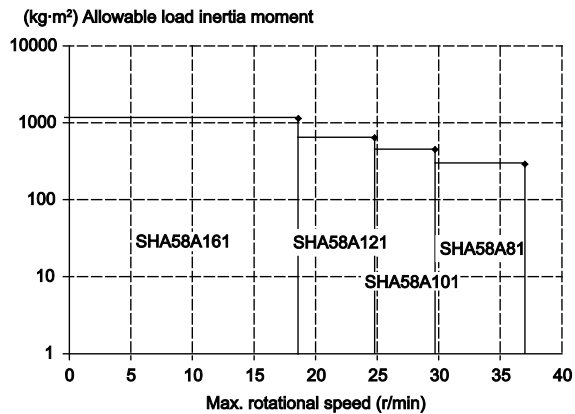
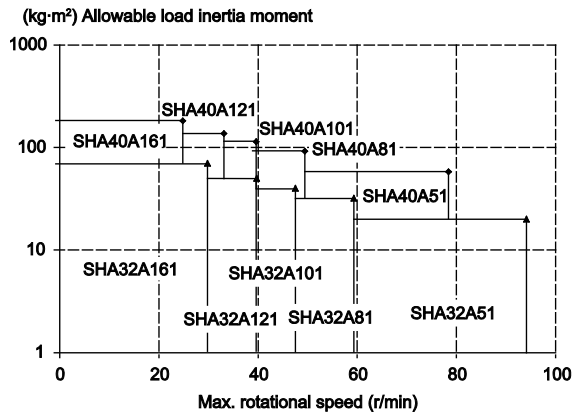
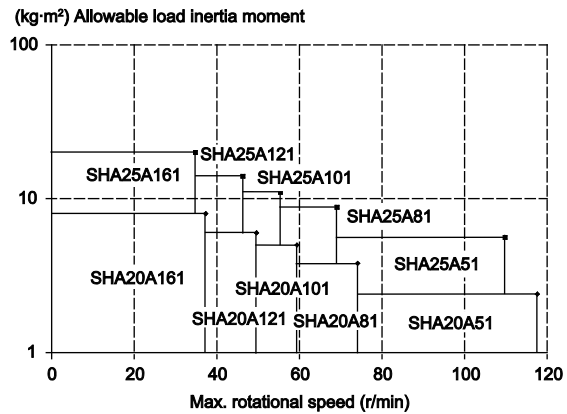

CG type

(kg·m²) Allowable load inertia moment

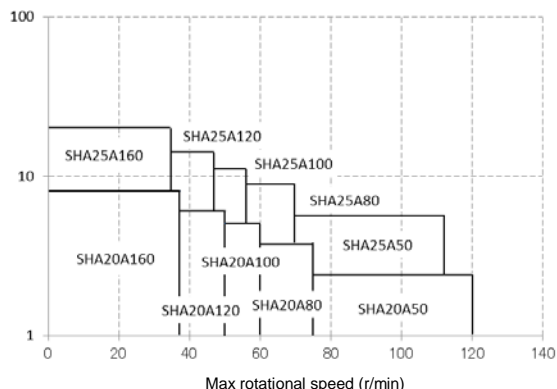

(kg·m²) Allowable load inertia moment

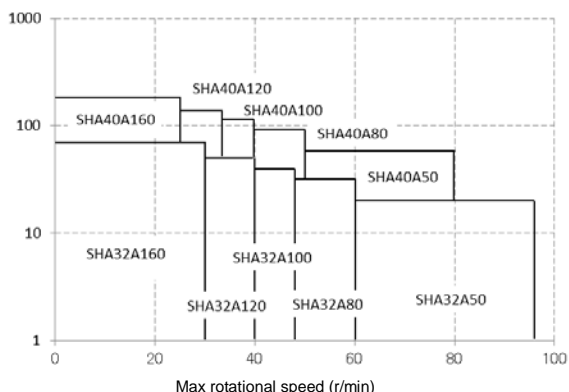

When making a preliminary selection of the actuator, make certain that the moment of inertia and maximum speed do not exceed the allowable values shown in the table below.

When a load with a large inertia moment is stopped and started frequently, a greater regenerative energy will be produced during braking. If the regenerative energy produced exceeds the absorption capacity of the built-in regenerative resistor of the servo driver, an additional regenerative resistor must be connected externally to the driver. For details, refer to the manual of your driver.

SG/HP

Actuator model		SHA20A				
		51	81	101	121	161
Reduction ratio		51:1	81:1	101:1	121:1	161:1
Max. speed	(rpm)	117.6	74.1	59.4	49.6	37.3
Actuator inertia (without brake)	$\text{kg} \cdot \text{m}^2$	0.23	0.58	0.91	1.3	2.3
	$\text{kgf} \cdot \text{cm} \cdot \text{s}^2$	2.4	6.0	9.3	13	24
Actuator inertia (with brake)	$\text{kg} \cdot \text{m}^2$	0.26	0.65	1.0	1.4	2.6
	$\text{kgf} \cdot \text{cm} \cdot \text{s}^2$	2.6	6.6	10	15	26
Max allowable load inertia	$\text{kg} \cdot \text{m}^2$	2.4	3.8	4.8	5.8	7.7
	$\text{kgf} \cdot \text{cm} \cdot \text{s}^2$	25	39	49	59	78

Actuator model		SHA25A					
		11	51	81	101	121	161
Reduction ratio		11:1	51:1	81:1	101:1	121:1	161:1
Max. speed	(rpm)	509.1	109.8	69.1	55.4	46.3	34.8
Actuator inertia (without brake)	$\text{kg} \cdot \text{m}^2$	0.029	0.56	1.4	2.2	3.2	5.6
	$\text{kgf} \cdot \text{cm} \cdot \text{s}^2$	0.30	5.7	14	22	32	57
Actuator inertia (with brake)	$\text{kg} \cdot \text{m}^2$	0.034	0.66	1.7	2.6	3.7	6.6
	$\text{kgf} \cdot \text{cm} \cdot \text{s}^2$	0.35	6.7	17	26	38	67
Max allowable load inertia	$\text{kg} \cdot \text{m}^2$	0.32	5.6	8.8	11	14	20
	$\text{kgf} \cdot \text{cm} \cdot \text{s}^2$	3.3	57	90	112	144	201

Actuator model		SHA32A					
		11	51	81	101	121	161
Reduction ratio		11:1	51:1	81:1	101:1	121:1	161:1
Max. speed	(rpm)	436.4	94.1	59.3	47.5	39.7	29.8
Actuator inertia (without brake)	$\text{kg} \cdot \text{m}^2$	0.091	2.0	5.1	8.0	11	20
	$\text{kgf} \cdot \text{cm} \cdot \text{s}^2$	0.93	21	52	81	117	207
Actuator inertia (with brake)	$\text{kg} \cdot \text{m}^2$	0.11	2.3	5.9	9.2	13	23
	$\text{kgf} \cdot \text{cm} \cdot \text{s}^2$	1.1	24	60	94	135	238
Max allowable load inertia	$\text{kg} \cdot \text{m}^2$	0.99	20	32	40	50	70
	$\text{kgf} \cdot \text{cm} \cdot \text{s}^2$	10	200	320	400	510	710

Actuator model		SHA40A					SHA58A			
		51	81	101	121	161	81	101	121	161
Reduction ratio		51:1	81:1	101:1	121:1	161:1	81:1	101:1	121:1	161:1
Max. speed	(rpm)	78.4	49.4	39.6	33.1	24.8	37.0	29.7	24.8	18.6
Actuator inertia (without brake)	$\text{kg} \cdot \text{m}^2$	5.0	13	20	28	50	96	149	214	379
	$\text{kgf} \cdot \text{cm} \cdot \text{s}^2$	51	130	202	290	513	980	1520	2180	3870
Actuator inertia (with brake)	$\text{kg} \cdot \text{m}^2$	6.1	15	24	34	61	106	165	237	420
	$\text{kgf} \cdot \text{cm} \cdot \text{s}^2$	62	157	244	350	619	1090	1690	2420	4290
Max allowable load inertia	$\text{kg} \cdot \text{m}^2$	58	92	114	137	182	290	450	640	1140
	$\text{kgf} \cdot \text{cm} \cdot \text{s}^2$	590	930	1170	1400	1860	2900	4600	6500	11600

Actuator model		SHA65A			
		81	101	121	161
Reduction ratio		81:1	101:1	121:1	161:1
Max. speed	(rpm)	34.6	27.7	23.1	17.4
Actuator inertia (without brake)	$\text{kg} \cdot \text{m}^2$	110	171	245	433
	$\text{kgf} \cdot \text{cm} \cdot \text{s}^2$	1120	1740	2500	4420
Actuator inertia (with brake)	$\text{kg} \cdot \text{m}^2$	120	187	268	475
	$\text{kgf} \cdot \text{cm} \cdot \text{s}^2$	1230	1910	2740	4850
Max allowable load inertia	$\text{kg} \cdot \text{m}^2$	360	560	810	1420
	$\text{kgf} \cdot \text{cm} \cdot \text{s}^2$	3700	5700	8200	14500

CG

Actuator model		SHA20A				
		50	80	100	120	160
Reduction ratio		50:1	80:1	100:1	120:1	160:1
Max. speed	(rpm)	120	75	60	50	37.5
Actuator inertia (without brake)	$\text{kg} \cdot \text{m}^2$	0.21	0.53	0.82	1.2	2.1
	$\text{kgf} \cdot \text{cm} \cdot \text{s}^2$	2.1	5.4	8.0	12	22
Actuator inertia (with brake)	$\text{kg} \cdot \text{m}^2$	0.23	0.60	0.94	1.3	2.4
	$\text{kgf} \cdot \text{cm} \cdot \text{s}^2$	2.4	6.1	9.6	14	24
Max allowable load inertia	$\text{kg} \cdot \text{m}^2$	2.4	3.8	4.8	5.8	7.7
	$\text{kgf} \cdot \text{cm} \cdot \text{s}^2$	25	39	49	59	78

Actuator model		SHA25A					SHA32A				
		50	80	100	120	160	50	80	100	120	160
Reduction ratio		50:1	80:1	100:1	120:1	160:1	50:1	80:1	100:1	120:1	160:1
Max. speed	(rpm)	112	70	56	46.7	35	96	60	48	40	30
Actuator inertia (without brake)	$\text{kg} \cdot \text{m}^2$	0.50	1.3	2.0	2.9	5.1	1.7	4.3	6.7	9.7	17
	$\text{kgf} \cdot \text{cm} \cdot \text{s}^2$	5.1	13	20	29	52	17	44	68	99	175
Actuator inertia (with brake)	$\text{kg} \cdot \text{m}^2$	0.60	1.5	2.4	3.4	6.1	2.0	5.1	7.9	11	20
	$\text{kgf} \cdot \text{cm} \cdot \text{s}^2$	6.1	16	24	35	62	20	52	81	116	207
Max allowable load inertia	$\text{kg} \cdot \text{m}^2$	5.6	8.8	11	14	20	20	32	40	50	70
	$\text{kgf} \cdot \text{cm} \cdot \text{s}^2$	57	90	112	144	201	200	320	400	510	710

Actuator model		SHA40A				
		50	80	100	120	160
Reduction ratio		50:1	80:1	100:1	120:1	160:1
Max. speed	(rpm)	80	50	40	33.3	25
Actuator inertia (without brake)	$\text{kg} \cdot \text{m}^2$	4.8	12	19	27	49
	$\text{kgf} \cdot \text{cm} \cdot \text{s}^2$	49	124	194	280	497
Actuator inertia (with brake)	$\text{kg} \cdot \text{m}^2$	5.8	15	23	33	59
	$\text{kgf} \cdot \text{cm} \cdot \text{s}^2$	59	150	235	338	601
Max allowable load inertia	$\text{kg} \cdot \text{m}^2$	58	92	114	137	182
	$\text{kgf} \cdot \text{cm} \cdot \text{s}^2$	590	930	1170	1400	1860

2

Selection guidelines

2-2 Change in load moment of inertia

SHA series actuators include Harmonic Drive® gearing that has a high reduction ratio. Because of this, the effects of changes in the load moment of inertia on the servo performance are minimal. In comparison to direct servo drive mechanisms, this benefit allows the load to be driven with a better servo response.

For example, assume that the load moment of inertia increases by N-times. The total inertia reflected to the motor shaft, having an effect on servo response, is as follows:

The symbols in the formulas are:

J_s : Total inertia moment converted to motor shaft

J_M : Inertia moment of motor

R: Reduction ratio of SHA series actuator

L: Ratio of load inertia moment to inertia moment of motor

N: Rate of change in load inertia moment

- Direct drive

$$\text{Before: } J_s = J_M(1+L) \quad \text{After: } J_s' = J_M(1+NL) \quad \text{Ratio: } J_s'/J_s = \frac{1+NL}{1+L}$$

- Driven by SHA series

$$\text{Before: } J_s = J_M \left(1 + \frac{L}{R^2} \right) \quad \text{After: } J_s' = J_M \left(1 + \frac{NL}{R^2} \right) \quad \text{Ratio: } J_s'/J_s = \frac{1+NL/R^2}{1+L/R^2}$$

With the SHA series, the value of R increases from 50 to 161, which means that the value increases substantially from $R^2 = 2,500$ to $R^2 = 25,921$. Then the ratio is $J_s'/J_s \approx 1$. This means that SHA drive systems are hardly affected by the load variation.

Therefore, it is not necessary to take changes of the load moment of inertia into consideration when selecting a SHA actuator or when setting up the initial driver parameters.

2-3 Verifying and examining load weights

The SHA series actuator incorporates a precise cross roller bearing for directly supporting an external load (output flange). To demonstrate the full ability of the actuator, verify the maximum load moment load as well as the life and static safety coefficient of the cross roller bearing.

Checking procedure

1 Verifying the maximum load moment load (Mmax)

Calculating the maximum load moment load (M_{max})



Verifying the maximum load moment load (M_{max}) is less than or equal to the permissible moment load (M_c)

2 Verifying life

Calculate the average radial load (F_{rav}) and average axial load (F_{aav}).



Calculate the radial load coefficient (X) and the axial load coefficient (Y).



Calculate the life of the bearing and verify the life is allowable.

3 Verifying the static safety coefficient

Calculate the static equivalent radial load (P_o).



Verify the static safety coefficient (f_s).

Specifications of the main roller bearing

The following table shows the specifications of the main roller bearings built in SHA actuators.

Table 1: Specifications of the cross roller bearings

Model	Item	Circular pitch of the roller (dp)	Offset amount (R)	Basic dynamic rated load (C)	Basic static rated load (Co)	Permissible moment load (Mc)	Moment stiffness (Km)
		mm	mm	kN	kN	Nm	$\times 10^4$ Nm/rad
SHA20A-SG		70	23.5	14.6	22	187	25.2
SHA20A-CG		70	19.5	14.6	22	187	25.2
SHA25A-SG		85	27.6	21.8	35.8	258	39.2
SHA25A-CG		85	21.6	21.8	35.8	258	39.2
SHA25A-HP		85	15.3	11.4	20.3	410	37.9
SHA32A-SG		111	34.9	38.2	65.4	580	100
SHA32A-CG		111	25.4	38.2	65.4	580	100
SHA32A-HP		111.5	15	22.5	39.9	932	86.1
SHA40A-SG		133	44	43.3	81.6	849	179
SHA40A-CG		133	29.5	43.3	81.6	849	179
SHA58A-SG		195	62.2	87.4	171	2180	531
SHA65A-SG		218	69	130	223	2740	741

Maximum load moment load

The formula below shows how to calculate the maximum load moment load (M_{max}).

Verify that the maximum load moment load (M_{max}) is less than or equal to the allowable load (M_c).

◆ **Formula (1): Maximum load moment load**

$$M_{max} = \frac{Fr_{max} \cdot (L_r + R) + Fa_{max} \cdot La}{1000}$$

Symbols used in the formula

M_{max}	Maximum load moment load	Nm	
Fr_{max}	Max. radial load	N	Refer to Fig.1.
Fa_{max}	Max. axial load	N	Refer to Fig.1.
L_r, La		mm	Refer to Fig.1.
R	Offset amount	mm	Refer to Fig.1 and Table 1.

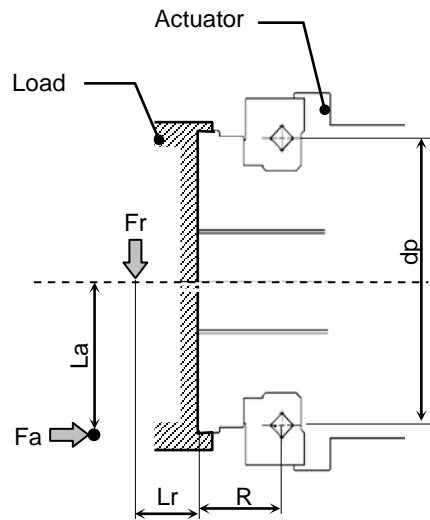

Fig. 1: External load action

Verifying life

Calculating average loads (average radial and axial loads, average output rotational speed)

When the radial and/or axial loads vary during motion, calculate and verify the life of the cross roller bearing converting the loads to their average values.

◆ **Formula (2): Average radial load (F_{rav})**

$$F_{rav} = \sqrt[10/3]{\frac{n_1 t_1 |Fr_1|^{10/3} + n_2 t_2 |Fr_2|^{10/3} + \dots + n_n t_n |Fr_n|^{10/3}}{n_1 t_1 + n_2 t_2 + \dots + n_n t_n}}$$

The maximum radial load in section t_1 is given by Fr_1 , while the maximum radial load in section t_3 is given by Fr_3 .

◆ **Formula (3): Average axial load (F_{aav})**

$$F_{aav} = \sqrt[10/3]{\frac{n_1 t_1 |Fa_1|^{10/3} + n_2 t_2 |Fa_2|^{10/3} + \dots + n_n t_n |Fa_n|^{10/3}}{n_1 t_1 + n_2 t_2 + \dots + n_n t_n}}$$

The maximum axial load in section t_1 is given by Fa_1 , while the maximum axial load in section t_3 is given by Fa_3 .

◆ **Formula (4): Average output rotational speed (N_{av})**

$$N_{av} = \frac{n_1 t_1 + n_2 t_2 + \dots + n_n t_n}{t_1 + t_2 + \dots + t_n}$$

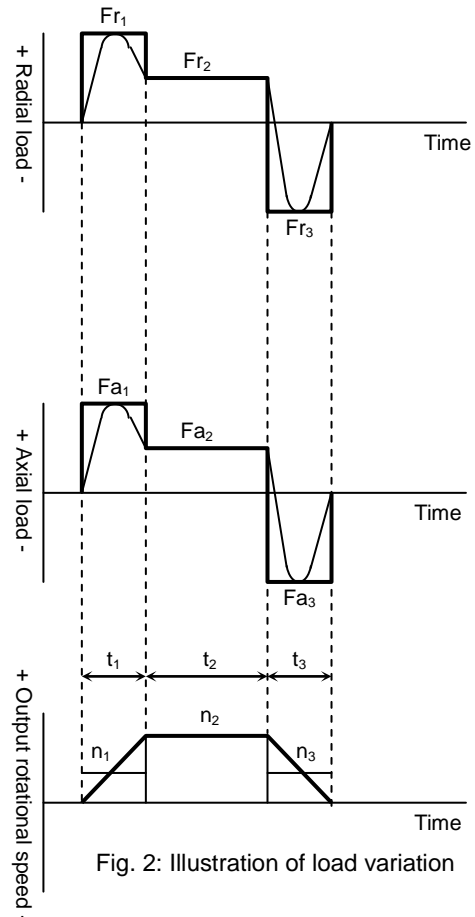

Fig. 2: Illustration of load variation

Radial load coefficient and axial load coefficient

Determine the values of radial load coefficient (X) and axial load coefficient (Y) based on the condition below.

Table 2: Radial load coefficient (X), axial load coefficient (Y)

◆ Formula (5)	X	Y
$\frac{F_{rav}}{F_{rav} + 2(F_{rav}(L_r + R) + F_{aav} \cdot L_a)/d_p} \leq 1.5$	1	0.45
$\frac{F_{rav}}{F_{rav} + 2(F_{rav}(L_r + R) + F_{aav} \cdot L_a)/d_p} > 1.5$	0.67	0.67

Symbols used in the formulas

F_{rav}	Average radial load	N	Refer to the average load.
F_{aav}	Average axial load	N	Refer to the average load.
L_r, L_a	_____	mm	Refer to Fig.1.
R	Offset amount	mm	Refer to Fig.1 and Table 1.
d_p	Pitch circle diameter of a roller	mm	Refer to Fig.1 and Table 1.

Dynamic equivalent radial load

◆ Formula (6): Dynamic equivalent radial load

$$P_c = X \cdot \left(F_{rav} + \frac{2(F_{rav}(L_r + R) + F_{aav} \cdot L_a)}{d_p} \right) + Y \cdot F_{aav}$$

Symbols used in the formulas

P_c	Dynamic equivalent radial load	N	
F_{rav}	Average radial load	N	Obtained by formula (2).
F_{aav}	Average axial load	N	Obtained by formula (3).
d_p	Pitch circle diameter of a roller	mm	Refer to Table 1.
X	Radial load coefficient	—	Refer to Table 2.
Y	Axial load coefficient	—	Refer to Table 2.
L_r, L_a	—	mm	Refer to Fig.1.
R	Offset amount	mm	Refer to Fig.1 and Table 1.

Life of cross roller bearing

Calculate the life of cross roller bearing with the formula (7):

◆ Formula (7): Cross roller bearing life

$$L_{B-10} = \frac{10^6}{60 \times N_{av}} \times \left(\frac{C}{f_w \cdot P_c} \right)^{10/3}$$

Symbols used in the formulas

L_{B-10}	Life	hour	—
N_{av}	Average output rotational speed	r/min	Obtained by formula (4).
C	Basic dynamic rated load	N	Refer to Table 1.
P_c	Dynamic equivalent radial load	N	Obtained by formula (6).
f_w	Load coefficient	—	Refer to Table 3.

Table 3: Load coefficient

Loaded state	f_w
Smooth operation free from impact/vibration	1 to 1.2
Normal operation	1.2 to 1.5
Operation subject to impact/vibration	1.5 to 3

Cross roller bearing life with oscillating motion

Use formula (8) to calculate the cross roller bearing life against oscillating movement.

◆ Formula (8): Cross roller bearing life (oscillating)

$$L_{oc} = \frac{10^6}{60 \times n_1} \times \frac{90}{\theta} \times \left(\frac{C}{f_w \cdot P_c} \right)^{10/3}$$

Symbols used in the formulas

L_{oc}	Life	hour	—
n_1	Number of reciprocating oscillation per min.	cpm	—
C	Basic dynamic rated load	N	Refer to Table 1.
P_c	Dynamic equivalent radial load	N	Obtained by formula (6).
f_w	Load coefficient	—	Refer to Table 3.
θ	oscillating angle/2	—	Refer to Fig.3.

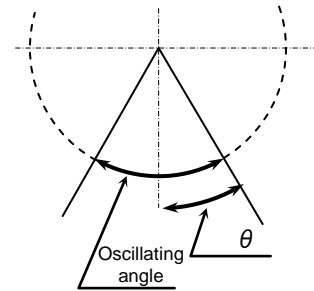

Fig. 3: Oscillating movement

If the oscillating angle is 5° or less, fretting wear may occur because the oil film does not form effectively on the contact surfaces between the race and rolling elements of the cross roller bearing. In such cases, consult with our engineering staff.

Verifying static safety coefficients

Static equivalent radial load

◆ Formula (9): Static equivalent radial load

$$P_o = F_{rmax} + \frac{2M_{max}}{d_p} + 0.44F_{amax}$$

Symbols used in the formulas

F_{rmax}	Max. radial load	N	Refer to Fig.1.
F_{amax}	Max. axial load	N	Refer to Fig.1.
M_{max}	Max. moment load	Nm	Refer to the maximum load weight calculation methods.
d_p	Pitch circle diameter of a roller	mm	Refer to Table 1.

Static safety coefficient

Generally, the static equivalent load is limited by the basic static rated load(C_o). However, the specific limit should be calculated according to the using conditions and required conditions. In this case, calculate the static safety coefficient (f_s) by formula (10).

Table 4 shows general values representing using conditions. Calculate the static equivalent radial load (P_o) by formula (9).

◆ Formula (10): Static safety coefficient

$$f_s = \frac{C_o}{P_o}$$

Symbols used in the formulas

f_s	Static safety coefficient	—	Refer to Table 4.
C_o	Basic static rated load	N	Refer to Table 1.
P_o	Static equivalent radial load	N	Obtained by formula (9).

Table 4: Static safety coefficients

Using conditions	f_s
High rotational accuracy is required, etc.	≥ 3
Operation subject to impact/vibration	≥ 2
Normal operation	≥ 1.5

2-4 Examining operating conditions

The actuator generates heat if started/stopped repeatedly or operated continuously at high speed. Accordingly, examine whether or not the generated heat can be accommodated. The study is as follows:

Calculate the actuator rotation speed

Calculate the required rotation speed (rpm) of the load driven by the SHA series. For linear operation, use the rotation speed conversion formula below:

$$\text{Rotation speed (r/min)} = \frac{\text{Linear travel speed (mm/min)}}{\text{Screw feed pitch (mm)}}$$

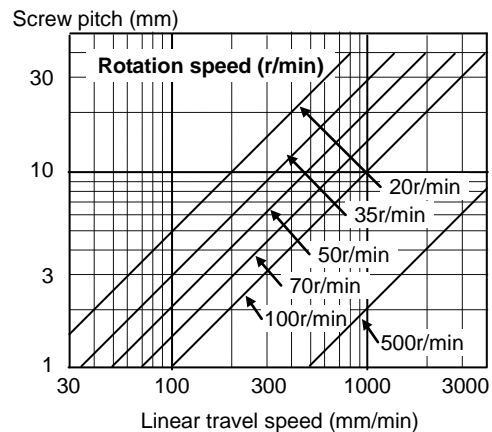

Select an appropriate reduction ratio from 11, 51, 81, 101, 121 and 161 so that the calculated rotation speed does not exceed the maximum rotational speed of the SHA series actuator.

Calculating and examining load moment of inertia

Calculate the load inertia moment of the load driven by the SHA series actuator.

Refer to [A-2 Calculating inertia moment] (P5-3) for the calculation.

Based on the calculated result, tentatively select an SHA actuator by referring to [Allowable load moment of inertia] (P2-1).

Load torque calculation

Calculate the load torque as follows:

- Rotary motion

The rotary torque for the rotating mass W on the ring of radius r from the center of rotation is shown in the figure to the right.

$$T = 9.8 \times \mu \times W \times r$$

T : Rotary torque (Nm)

μ : Friction coefficient

W : Mass (kg)

r : Average radius of friction side (m)

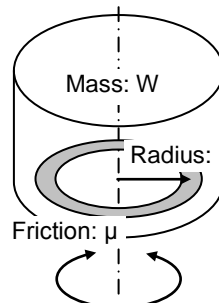

Example of rotary torque calculation (friction coefficient = 0.1)
SHA: 20% torque of maximum torque is shown.

The right graph gives a calculation example when the friction coefficient μ is assumed as 0.1 and the horizontal axis and vertical axis represent mass and rotational radius of friction side, respectively. The actuator torque value shown in the graph indicates 20% of the maximum torque.

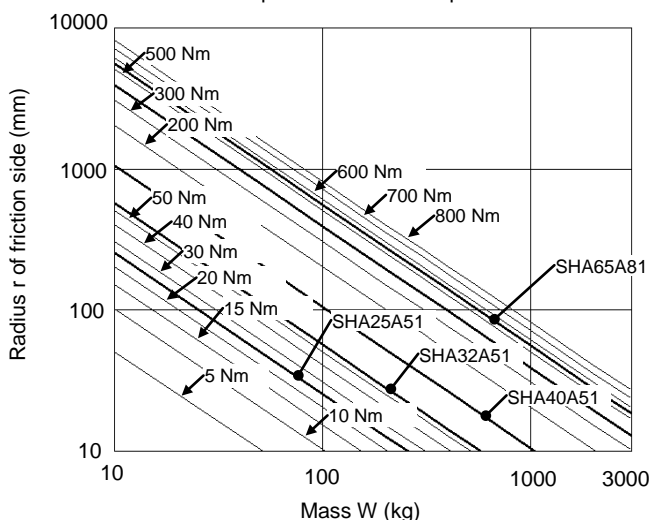

- Linear operation (horizontal operation)

The rotary torque when the mass W moves horizontally due to the screw of pitch P is shown below.

$$T = 9.8 \times \mu \times W \times \frac{P}{2 \times \pi}$$

T : Rotary torque (Nm)

μ : friction coefficient

W : mass (kg)

P : Screw feed pitch (m)

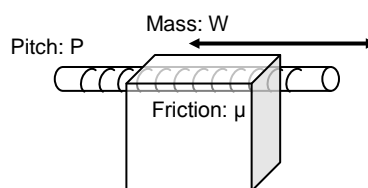

- Linear operation (vertical operation)

The rotary torque when the mass W moves vertically due to the screw of pitch P is shown below.

$$T = 9.8 \times W \times \frac{P}{2 \times \pi}$$

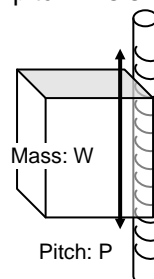

Acceleration and deceleration time

Calculate acceleration and deceleration times for the selected actuator.

$$\text{Acceleration time: } t_a = k \times (J_A + J_L) \times \frac{2 \times \pi}{60} \times \frac{N}{T_M - T_L}$$

$$\text{Deceleration time: } t_d = k \times (J_A + J_L) \times \frac{2 \times \pi}{60} \times \frac{N}{T_M + 2 \times T_F + T_L}$$

t_a : Acceleration time (s)
 t_d : Deceleration time (s)

k : Acceleration reduction coefficient 1 to 1.5

The total positioning time may become shorter if the acceleration is lowered for the purpose of reducing the settling time after positioning.

J_A : Actuator inertia moment ($\text{kg} \cdot \text{m}^2$)

J_L : Load inertia moment ($\text{kg} \cdot \text{m}^2$)

N : Actuator rotation speed (r/min)

T_M : Maximum actuator torque (Nm)

T_F : Actuator friction torque (Nm)

$$T_F = K_T \times I_R - T_R$$

K_T : Torque constant (Nm/A)

T_R : Allowable continuous torque (Nm)

I_R : Allowable continuous current (A)

T_L : Load torque (Nm); The polarity is positive (+) when the torque is applied in the rotation direction, or negative (-) when it is applied in the opposite direction.

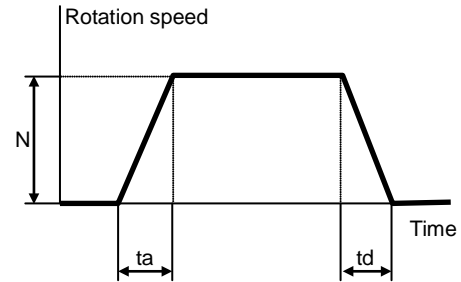

● Calculation example 1

Select an actuator that best suits the following operating conditions:

- Rotation speed: 80 rpm
- Load inertia moment: $1.5 \text{ kg} \cdot \text{m}^2$
- Since the load mechanism is mainly inertia, the load torque is negligibly small.

(1) After applying these conditions to the graph in [2-1], SHA25A51SG-B09A200 is tentatively selected.

(2) From the rated table, the following values are obtained: $J_A = 0.56 \text{ kg} \cdot \text{m}^2$, $T_M = 127 \text{ Nm}$, $T_R = 41 \text{ Nm}$, $K_T = 19 \text{ Nm/A}$, $I_R = 3 \text{ A}$.

(3) Based on the above formula, the actuator's friction torque T_F is calculated as $19 \times 3 - 41 = 16 \text{ Nm}$.

(4) If $k = 1.3$, the acceleration time and deceleration time can be obtained as follows from the above formulas:

$$t_a = 1.3 \times (0.56 + 1.5) \times 2 \times \pi / 60 \times 80 / 127 = 0.177 \text{ s}$$

$$t_d = 1.3 \times (0.56 + 1.5) \times 2 \times \pi / 60 \times 80 / (127 + 2 \times 16) = 0.141 \text{ s}$$

(5) If the calculated acceleration/deceleration times are too long, correct the situation by:

- Reducing load inertia moment
- Selecting an actuator with a larger frame size

Examining effective torque and average rotation speed

One way to check if the heat generated from the actuator during operation would present a problem is to determine if the point of operation, determined by the effective torque and average rotation speed, is inside the continuous motion range explained in [1-14 Operable range].

Using the following formula, calculate the effective torque T_m and average rotation speed N_{av} when the actuator is operated repeatedly in the drive pattern shown to the right.

$$T_m = \sqrt{\frac{T_a^2 \times t_a + T_r^2 \times t_r + T_d^2 \times t_d}{t}}$$

$$N_{av} = \frac{N/2 \times t_a + N \times t_r + N/2 \times t_d}{t}$$

- t_a : Acceleration time from speed 0 to N (s)
 t_d : Deceleration time from speed N to 0 (s)
 t_r : Operation time at constant speed N (s)
 t : Cycle time (s)
 T_m : Effective torque (Nm)
 T_a : Torque during acceleration (Nm)
 T_r : Torque at constant speed (Nm)
 T_d : Torque during deceleration (Nm)
 N_{av} : Average rotation speed (r/min)
 N : Rotation speed at constant speed (r/min)

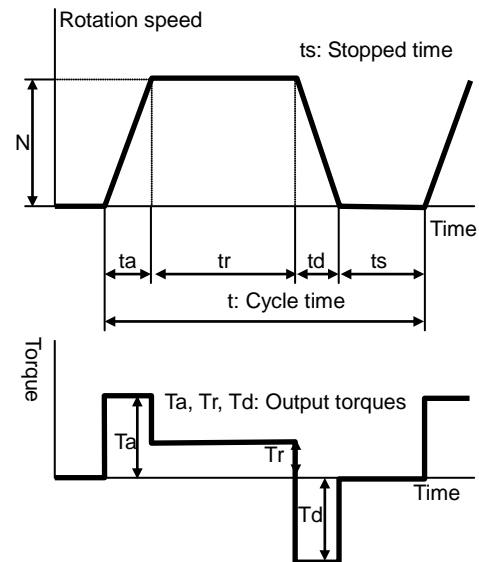

● Calculation example 2

An example of SHA25A51SG-B09A200 is explained.

Operating conditions: Accelerate an inertia load and then let it move at a constant speed, followed by deceleration, based on conditions similar to those used in calculation example 1. The travel angle per cycle is 120° and the cycle time is 1 second.

- (1) The travel angle is calculated from the area of the rotation speed vs. time diagram shown above. In other words, the travel angle is calculated as follows:

$$\theta = (N / 60) \times \{t_r + (t_a + t_d) / 2\} \times 360$$

$$\text{Accordingly, } t_r = \theta / (6 \times N) - (t_a + t_d) / 2$$

When $\theta = 120^\circ$, and $t_a = 0.177$ (s), $t_d = 0.141$ (s), $N = 80$ (r/min) in calculation example 1, are applied to this formula, t_r is calculated as 0.091 (s).

- (2) Next, calculate the torque during acceleration and torque during deceleration. Based on the acceleration/deceleration time formulas in the preceding section, the relational expressions for torque during acceleration and torque during deceleration if $k = 1$ are as follows:

$$T_a = (J_a + J_L) \times 2 \times \pi / 60 \times N / t_a + T_L$$

$$T_d = (J_a + J_L) \times 2 \times \pi / 60 \times N / t_d - 2 \times T_F - T_L$$

When the values in calculation example 1 are applied to this formula, $T_a = 98$ (Nm) and $T_d = 90$ (Nm) are obtained.

- (3) Calculate the effective torque. Apply the values in (1) and (2), and $T_r = 0$ (Nm) and $t = 1$ (s), to the above formulas.

$$T_m = \sqrt{\frac{98^2 \times 0.177 + 0^2 \times 0.091 + 90^2 \times 0.141}{1}} = 53 \text{ Nm}$$

- (4) Calculate the average rotation speed. Apply the values in (1), and $N = 80$ (r/min) and $t = 1$ (s), to the above formulas.

$$N_{av} = \frac{80/2 \times 0.177 + 80 \times 0.091 + 80/2 \times 0.141}{1} = 20 \text{ r/min}$$

(5) The figure on the right shows the point of operation determined by the effective torque and average rotation speed calculated above, plotted on the graph of operable range of SHA25A51, exceeding the continuous motion range. The conclusion is that this actuator cannot be operated continuously under these conditions. Accordingly,

- ◆ the operation pattern
- ◆ load (possible reduction)
- ◆ actuator model No.

etc., must be reexamined.

The following formula is a modified version of the formula for effective torque. By applying the value of allowable continuous torque to T_m in this formula, the allowable cycle time can be calculated.

$$t = \frac{T_a^2 \times t_a + T_r^2 \times t_r + T_d^2 \times t_d}{T_m^2}$$

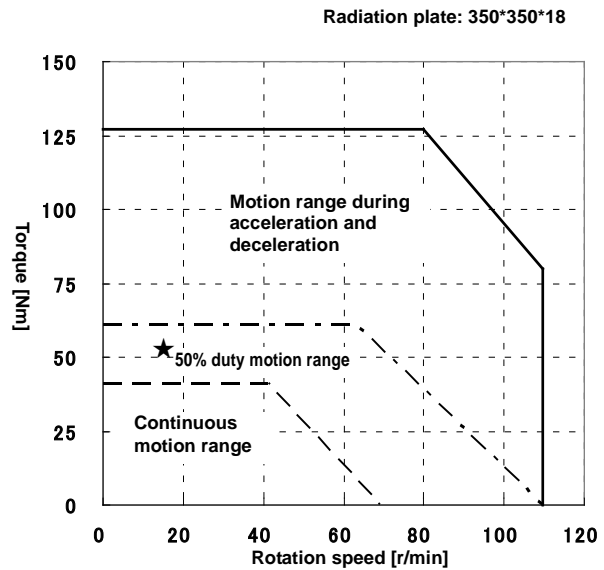

Operable range of SHA25A51

Apply the following: $T_a = 98 \text{ Nm}$, $T_r = 0 \text{ Nm}$, $T_d = 90 \text{ Nm}$, $T_m = 41 \text{ Nm}$, $t_a = 0.177 \text{ s}$, $t_r = 0.091 \text{ s}$, $t_d = 0.141 \text{ s}$ Then, the following equation is obtained:

$$t = (98^2 \times 0.177 + 90^2 \times 0.141) / 41^2 = 1.69 \text{ s}$$

Based on the result, setting the cycle time to 1.7 seconds or more to provide a longer stopped time gives $T_m = 41 \text{ Nm}$ or less, thereby permitting continuous operation within the allowable continuous torque.

Caution

- The aforementioned continuous duty range represents an allowable range when the actuator is installed on the specified aluminum heatsink and operated under natural air cooling. If the radiation area of the mounting member is smaller or the heat conduction of the material is poor, adjust the operating conditions to limit the temperature rise of the actuator to 40° C or less as a guide.

Chapter 3

Installing the SHA actuator

The following explains the installation procedures of the actuators.

3-1 Receiving Inspection.....	3-1
3-2 Notices on handling.....	3-2
3-3 Location and installation	3-6

3-1 Receiving Inspection

Check the following items after unpacking the package.

3

Installing the SHA actuator

Inspection procedure

1 Check the items thoroughly for damage sustained during transportation.

If any item is damaged, immediately contact the dealer.

2 Confirm the actuator is what you ordered.

The nameplate is found on the rear end face of the SHA series actuator. Check the TYPE field on the nameplate to confirm that it is indeed the model you have ordered. If any item is wrong, immediately contact the dealer.

Refer to the section 1-2 in this manual for the detail of the model codes.

3 Check driver combinations.

The applicable SHA series actuator models are shown in the ADJUSTED FOR USE WITH field of the nameplate on the HA-800 driver.

4 Check driver input voltages.

The driver's model code is shown in the TYPE field of the driver's nameplate. The last three digits of this model code indicate the input voltage to be input.

100: indicates a single phase 100VAC power supply.

200: indicates a 3-phase/single-phase 200VAC power supply.

If the voltage to be supplied is different from the label voltage, immediately contact the dealer it was purchased from.



WARNING

Only connect the actuator specified on the driver label.

The characteristics of this driver have been adjusted according to the actuator. Wrong combinations of drivers and actuators may cause low torque problems or overcurrent that may cause thermal damage to the actuator, injury or fire.

Do not connect a supply voltage other than the voltage specified on the driver label.

The wrong power supply voltage may damage the driver, resulting in physical injury or fire.

3-2 Notices on handling

Handle the SHA series actuator carefully by observing the notices specified below.



- (1) Do not apply any excessive force or impact, especially to the actuator's output shaft.
- (2) Do not put the SHA series actuator on a table, shelf, etc., where the actuator could easily fall.
- (3) Do not connect the actuator terminals directly to the power supply. The actuator may burn and cause fire or electric shock.
- (4) The allowable storage temperature is -20 to $+60^{\circ}\text{C}$. Do not expose the actuator to direct sunlight for long periods of time or store it in areas in low or high temperature.
- (5) The allowable relative storage humidity is 80% or less. Do not store the actuator in a very humid place or in areas where temperatures are likely to fluctuate greatly during day and night.
- (6) Do not use or store the actuator in locations subject to flammable or corrosive gases or dust particles.
- (7) The large models (SHA58A, SHA65A) are heavy. Handling these models may cause lower back pain. Injury may occur if the actuator falls and you are pinned underneath. Handle your actuator with due care by wearing safety shoes or take other proper precautions. Use supporting fixtures and lifting equipment as necessary for safe handling.

Installation and transmission torque

Examples of actuator assembly are shown below. Assembly examples 1 and 2 are for SHA-SG. Assembly examples 3 and 4 are for SHA-CG. Use high-tension bolts and tighten them with a torque wrench to control the tightening torque. In assembly example 2, use flat washers because the tightening torque is high and the actuator flange is made of aluminum.

SHA-SG assembly example

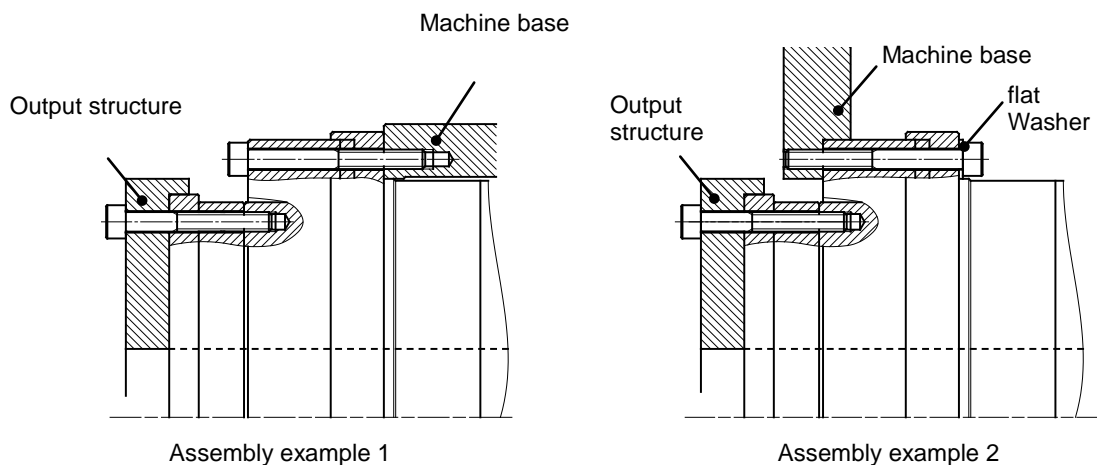

SHA-CG assembly example

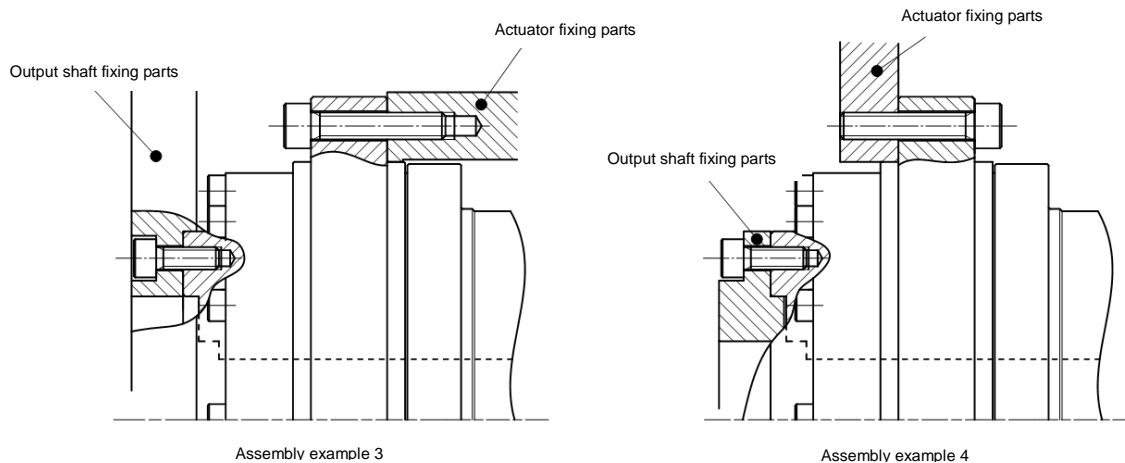

- Recommended tightening torque and transmission torque
SG/HP type

Item \ Model		SHA20A		SHA25A		SHA32A	
		Output shaft	Actuator	Output shaft	Actuator	Output shaft	Actuator
Number of bolts, size		16-M3	12-M3	16-M4 (12-M4)	12-M4	16-M5 (12-M5)	12-M5
Bolt installation P.C.D.	mm	62	84	77	102 (127)	100	132 (157)
	Nm	2.0	2.0	4.5	4.5 (3.2)	9	9 (6.4)
Tightening torque	kgf·m	0.20	0.20	0.46	0.46 (0.33)	0.92	0.92 (0.65)
	Nm	203	206	433 (325)	430 (381)	900 (675)	891 (754)
Transmission torque	kgf·m	21	21	44 (33.2)	44 (38.9)	92 (68.9)	91 (76.9)

The values in parenthesis are those combined with the HPF hollow planetary speed reducer.

Item \ Model		SHA40A		SHA58A		SHA65A	
		Output shaft	Actuator	Output shaft	Actuator	Output shaft	Actuator
Number of bolts, size		16-M6	12-M6	12-M10	16-M8	16-M10	16-M10
Bolt installation P.C.D.	mm	122	158	178	226	195	258
	Nm	15.3	15.3	74	37	74	74
Tightening torque <small>Notes 1, 2</small>	kgf·m	1.56	1.56	7.5	3.8	7.5	7.5
	Nm	1560	1510	4940	5230	7210	9550
Transmission torque <small>Note 3</small>	kgf·m	159	154	504	533	735	974

CG type

Item \ Model		SHA20A		SHA25A	
		Output shaft	Actuator	Output shaft	Actuator
Number of bolts, size		12-M4	6-M5	12-M5	8-M6
Bolt installation P.C.D.	mm	60	107	72	131
Tightening torque <small>Notes 1, 2</small>	Nm	4.5	6.4	9	11
	kgf·m	0.46	0.65	0.92	1.1
Transmission torque <small>Note 3</small>	Nm	253	257	486	600
	kgf·m	26	26	50	61

Item \ Model		SHA32A		SHA40A	
		Output shaft	Actuator	Output shaft	Actuator
Number of bolts, size		12-M6	12-M6	12-M8	8-M10
Bolt installation P.C.D.	mm	96	162	116	203
Tightening torque <small>Notes 1, 2</small>	Nm	15.3	11	37	52
	kgf·m	1.6	1.1	3.8	5.3
Transmission torque <small>Note 3</small>	Nm	918	1114	2012	2639
	kgf·m	94	114	205	269

Note 1) The female thread material is premised to withstand the bolt tightening torque

2) Recommended bolt: Hexagonal bolt per JIS B 1176 Intensity category: JIS B 1051 12.9 or higher

3) Calculation conditions Torque efficiency: 0.2 Tightening efficiency: 1.4 Tightening friction coefficient: 0.15

Precautions on installation

When designing the assembly, take note that application of any abnormal or excessive force that causes deformation of the installation surface may result in performance drop. To demonstrate the excellent performance of the SHA series actuator fully, take note of the following points:

- Warping or deformation on the machine mounting surfaces
- Foreign matter on the mounting surfaces
- Raised burrs or deformation around the tapped mounting holes
- Insufficient chamfering of mounting pilot diameter
- Mounting pilot diameter is out-of-round

When the installation method is as shown in assembly example 2 mentioned above, the recessing shown to the right is recommended for the spigot corner section on the actuator fixing member.

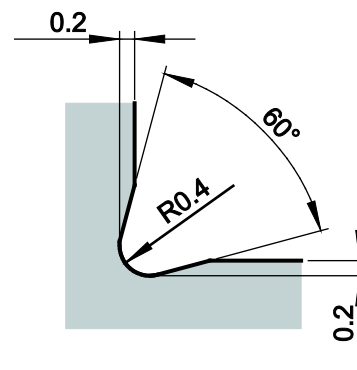

Use of positioning pins

The SHA series SG type actuator has positioning pin holes in the output rotary unit and flange fixed to the actuator. The SHA series CG type has positioning pin holes only in the output rotary unit. Use these pins as necessary. For details, refer to [1-6 External dimensions] (P1-11) or the illustrated specifications.

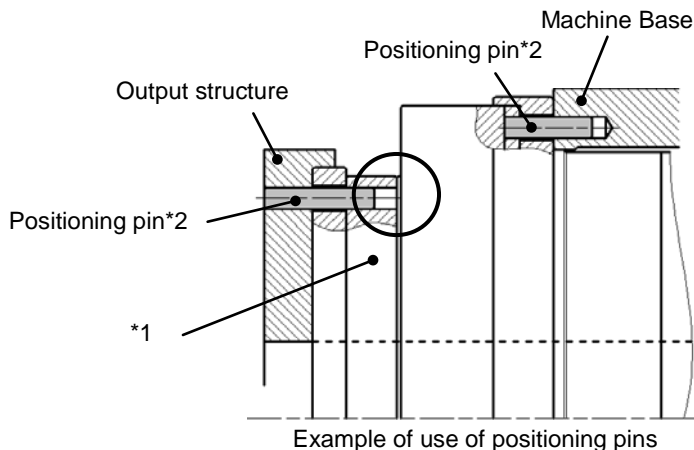

- *1. Do not drive positioning pins into the output rotary unit, but keep proper fitting clearances to the actuator parts. Failure to do so may result in lower positional accuracy.
- *2. The hollow planetary speed reducer model is not equipped with a positioning pin.

Surface treatments

Standard SHA series actuators are given the following surface treatments:

SG/HP type

Location	Surface treatments
Housing	No treatment (aluminum material is exposed)
Output shaft bearing	Raydent
Speed reducer rotating part	Chrome plating
Output flange	Nickel plating Raydent
Hollow shaft (sleeve)	Nickel plating
Bolt	Chrome plating

CG type

Location	Surface treatments
Housing	No treatment (aluminum material is exposed)
Output flange	Raydent treatment
Speed reducer rotating part	Raydent treatment, enamel resin is applied to some surfaces
Hollow shaft (sleeve)	Nickel plating
Bolt	Chrome plating or Nickel plating

The surface treatments given to SHA series actuators do not fully prevent rust.

3-3 Location and installation

Operating Environment

The environmental conditions of the installation location for SHA series actuators must be as follows. Select an appropriate installation location and observe these conditions without fail.

- ◆ Operating temperature: 0 to 40°C
The temperature in the cabinet may be higher than the atmosphere depending on the power loss of housed devices and size of the cabinet. Plan the cabinet size, cooling system, and device locations so the ambient temperature of the actuator is kept 40°C or below.
- ◆ Operating humidity: Relative humidity of 20 to 80%.
Make sure no condensation occurs. Take note that condensation is likely to occur in a place where there is a large temperature change between day and night or when the actuator is started/stopped frequently.
- ◆ Vibration: 25 m/s² (10 to 400Hz) or less (Refer to [1-13 Vibration resistance] (P1-43))
- ◆ Impact: 300 m/s² or less (Refer to [1-12 Shock resistance] (P1-42))
- ◆ Use environment: Free from condensation, metal powder, corrosive gases, water, oil mist, flammable gases, etc.
- ◆ Protection class: Standard products are structurally designed to meet the IP-54 requirements.

The protection class against water entry is as follows:
4: Protected against water splashed from all directions.

The protection class against contact and entry of foreign matter is as follows:
5: Protected against entry of dust/dirt. Entry of water or foreign matter caused by incomplete protection must not affect the operation of the system.

However, rotating and sliding areas (oil seal areas) and connectors of SHA20, 25, 32 and 40 are not IP-54-compliant. Connectors of SHA58 and 65 are protected in fitted conditions.

- ◆ Locate the driver indoors or within an enclosure. Do not expose it to the sunlight.
- ◆ Altitude: lower than 1,000 m above sea level
- ◆ The oil seals in rotating and sliding areas do not fully prevent leakage of lubricant. If the actuator is used in a clean room, etc., provide additional oil leakage prevention measures.

Installation

The SHA series actuator drives mechanical load system at high accuracy. When installing the actuator, pay attention to precision and do not tap the actuator output part with a hammer, etc. The actuator houses an encoder. Excessive impact may damage the encoder.

Installation procedure

1 Align the axis of rotation of the actuator and the load mechanism precisely.

Note 1: Perform this alignment carefully, especially when a rigid coupling is used. Even slight misalignment may cause the permissible load of the actuator to be exceeded, resulting in damage to the output shaft.

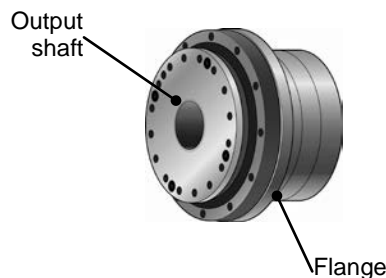

2 Connect the driver and wiring.

An extension cable is provided. Use it when wiring the driver. For details on wiring, refer to [1-15 Cable specifications] (P1-59) and the manual of your HA-800 driver.

3 Wire the motor cable and encoder cable.

Do not pull the cables with a strong force. The connection points may be damaged. Install the cable with slack not to apply tension to the actuator. Provide a sufficient bending radius (at least 6 times the cable diameter), especially when the cable flexes.

Caution

- Do not bring strong magnetic objects (magnet chucks, permanent magnets, etc.) near the rear cover of the actuator. Encoder abnormality may result.
- This encoder retains absolute positions when the power is turned OFF by means of the driver's battery or its own built-in capacitor. If the encoder cable is disconnected for maintenance, etc., turn on the driver power and charge the backup capacitor first. After 3 hours of charge, the encoder cable can be disconnected for 30 minutes, provided that the axis is stopped and ambient temperature is 25°C. However, when the backup capacitor is deteriorated, the absolute positions may not be retained.



Do not disassemble/reassemble the actuator.
May cause damage to electrical and mechanical components.

Chapter 4

Options

This chapter explains the options available for the SHA series actuator.

4-1 Options.....	4-1
------------------	-----

4-1 Options

Origin and end limit sensors (option code: L)

This option includes sensors that are directly connected to the output shaft on the rear of the actuator. Use this option if a mechanical origin is required (when the virtual origin of the absolute encoder is not sufficient) or you want to define an operation range as a safety measure. SHA20A is not compatible.

Option for side exit cables (option code: Y)

This option allows the motor and encoder cables to exit from the side of the actuator. Use this option if the actuator is housed in a system and there is not enough room for cables to exit at the rear of the housing. This option is not available with the SHA20 (SG type), SHA58 and SHA65. Contact us for details.

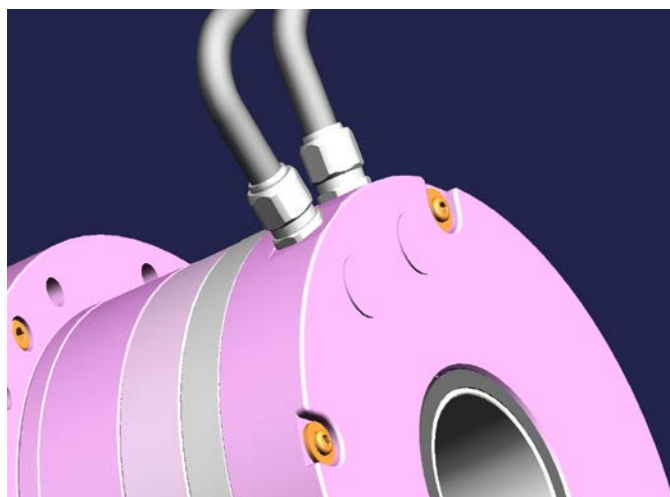

Output shaft single revolution absolute model (option code: S)

With the standard encoder, when it continues to rotate in just one direction, the absolute encoder eventually exceeds the number of revolutions that can be detected with multi-revolution detection and it becomes impossible to manage position information accurately.

With the output shaft single revolution absolute model, each time the output shaft turns through single revolution, the cumulative multi revolution counter is cleared to 0. This is how position information is accurately managed when the shaft continuously turns in just one direction. To use this function, it is necessary to setup a driver. Refer to "HA-800 Series AC Servo Driver Manual". This model is compatible with CG type only.

Stand (CG type only)

A stand is available for purchase to use the CG type for table drive. For details, contact our sales office.

Extension cables

These extension cables are used to connect the SHA series actuators and HA-800 drivers. Two types of extension cables are available for motor (including brake wire) and absolute encoder. **You must use an extension cable to connect your SHA series actuator and HA-800 driver.**

Motor extension cable:

- **SHA 20, 25, 32, 40 (Size 40 requires an extension cable when combined with the HA-800-6D/E.)**

EWD-MB**⁻A06-TN3

Cable length (03 = 3m, 05 = 5m, 10 = 10m)

(** in the model code indicates the cable length (03 = 3m, 05 = 5m, 10 = 10m).)

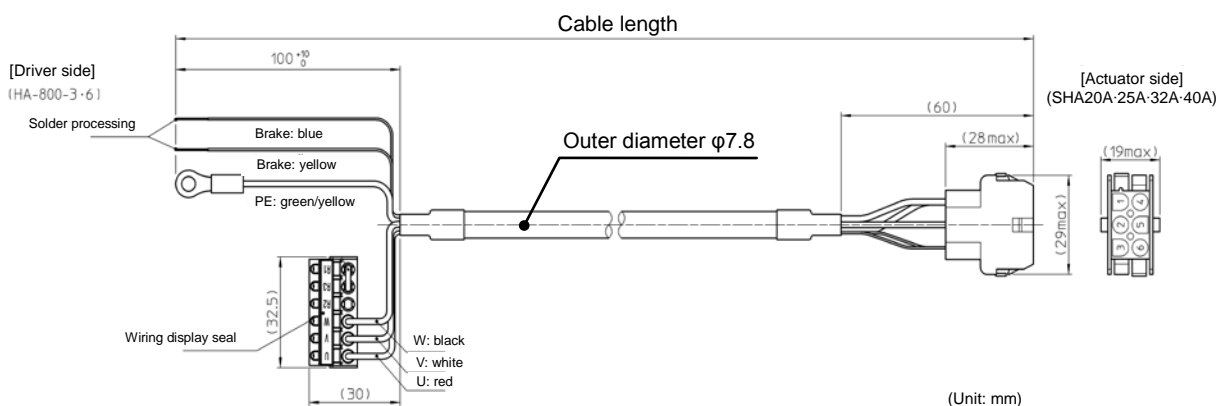

- **SHA 40 (when combined with the HA-800-24D/E)**

EWD-MB**⁻A06-TMC

Cable length (03 = 3m, 05 = 5m, 10 = 10m)

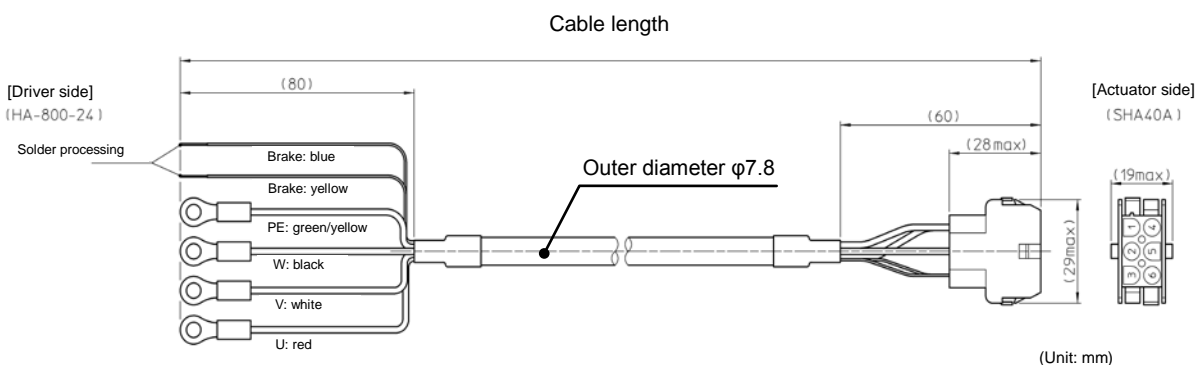

● **SHA 58, 65**
EWD-MB**^{***}-D09-TMC

Cable length (03 = 3m, 05 = 5m, 10 = 10m)

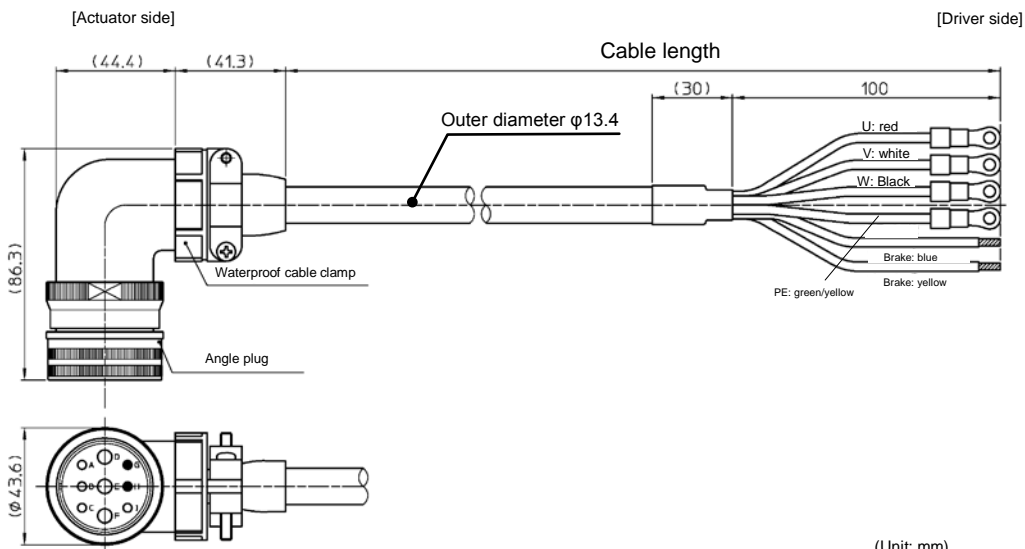

(Unit: mm)

Absolute encoder extension cable:

- **SHA 20, 25, 32, 40**
EWD-S**-A08-3M14

Cable length (03 = 3m, 05 = 5m, 10 = 10m)

(** in the model code indicates the cable length (3m, 5m, 10m).)

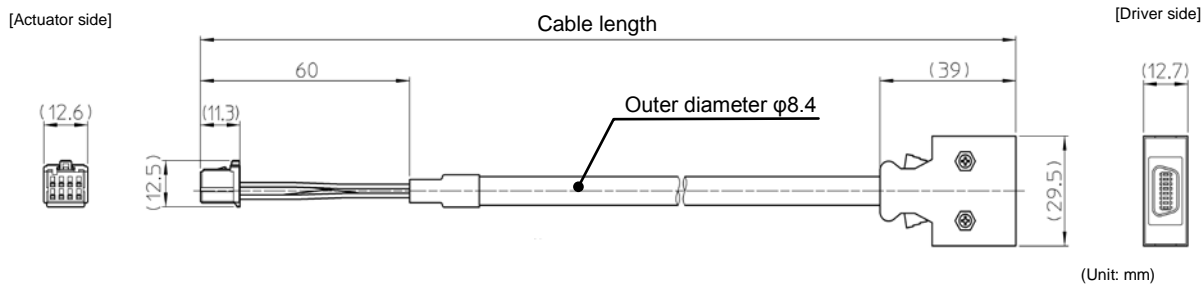

- **SHA 58, 65**
EWD-S**-D10-3M14

Cable length (03 = 3m, 05 = 5m, 10 = 10m)

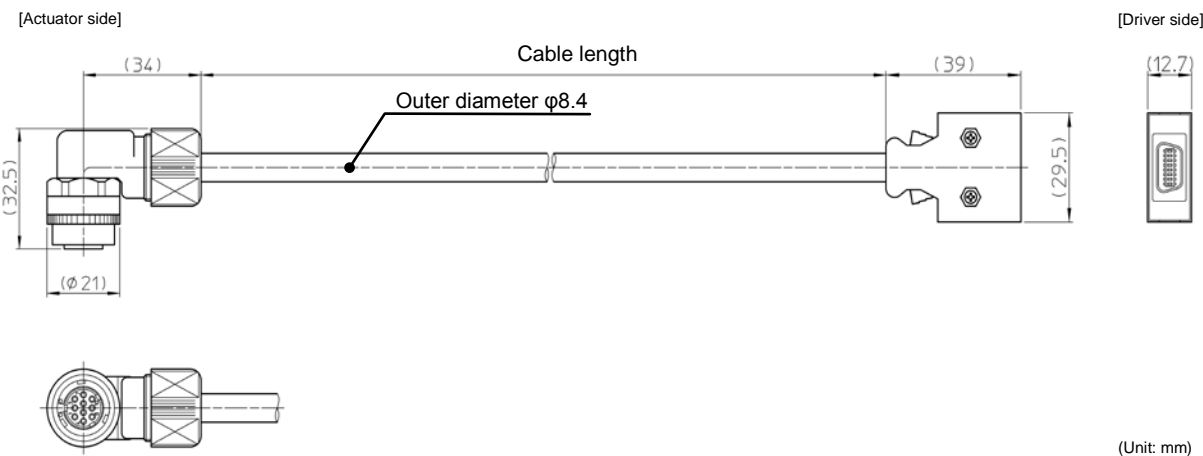

4

Options

Appendix

A-1 Unit conversion.....	5-1
A-2 Calculating inertia moment.....	5-3

A-1 Unit conversion

This manual employs SI system for units. Conversion factors between the SI system and other systems are as follows:

(1) Length

SI system	m	
Unit	ft.	in.
Factor	3.281	39.37

(2) Linear speed

SI system	m/s			
Unit	m/min	ft./min	ft./s	in/s
Factor	60	196.9	3.281	39.37

(3) Linear acceleration

SI system	m/s ²			
Unit	m/min ²	ft./min ²	ft./s ²	in/s ²
Factor	3600	1.18x10 ⁴	3.281	39.37

(4) Force

SI system	N		
Unit	kgf	lb (force)	oz (force)
Factor	0.102	0.225	4.386

(5) Mass

SI system	kg	
Unit	lb.	oz.
Factor	2.205	35.27

(6) Angle

SI system	rad		
Unit	deg.	min.	sec.
Factor	57.3	3.44x10 ³	2.06x10 ⁵

(7) Angular speed

SI system	rad/s			
Unit	deg/s	deg/min	r/s	r/min
Factor	57.3	3.44x10 ³	0.1592	9.55

Unit	ft.	in.
Factor	0.3048	0.0254
SI system	m	

Unit	m/min	ft./min	ft./s	in/s
Factor	0.0167	5.08x10 ⁻³	0.3048	0.0254
SI system	m/s			

Unit	m/min ²	ft./min ²	ft./s ²	in/s ²
Factor	2.78 x10 ⁻⁴	8.47x10 ⁻⁵	0.3048	0.0254
SI system	m/s ²			

Unit	kgf	lb (force)	oz (force)
Factor	9.81	4.45	0.278
SI system	N		

Unit	lb.	oz.
Factor	0.4535	0.02835
SI system	kg	

Unit	deg.	min.	sec.
Factor	0.01755	2.93x10 ⁻⁴	4.88x10 ⁻⁶
SI system	rad		

Unit	deg/s	deg/min	r/s	r/min
Factor	0.01755	2.93x10 ⁻⁴	6.28	0.1047
SI system	rad/s			

(8) Angular acceleration

SI system	rad/s ²	
	↓	
Unit	deg/s ²	deg/min ²
Factor	57.3	3.44x10 ³

Unit	deg/s ²	deg/min ²
Factor	0.01755	2.93x10 ⁻⁴

SI system	rad/s ²
-----------	--------------------

(9) Torque

SI system	N·m			
	↓			
Unit	kgf·m	lb·ft	lb·in	oz·in
Factor	0.102	0.738	8.85	141.6

Unit	kgf·m	lb·ft	lb·in	oz·in
Factor	9.81	1.356	0.1130	7.06x10 ⁻³

SI system	N·m
-----------	-----

(10) Inertia moment

SI system	kg·m ²							
	↓							
Unit	kgf·m·s ²	kgf·cm·s ²	lb·ft ²	lb·ft·s ²	lb·in ²	lb·in·s ²	oz·in ²	oz·in·s ²
Factor	0.102	10.2	23.73	0.7376	3.42x10 ³	8.85	5.47x10 ⁴	141.6

Unit	kgf·m·s ²	kgf·cm·s ²	lb·ft ²	lb·ft·s ²	lb·in ²	lb·in·s ²	oz·in ²	oz·in·s ²
Factor	9.81	0.0981	0.0421	1.356	2.93x10 ⁻⁴	0.113	1.829x10 ⁻⁵	7.06x10 ⁻³

SI system	kg·m ²
-----------	-------------------

(11) Torsional spring constant, moment stiffness

SI system	N·m/rad				
	↓				
Unit	kgf·m/rad	kgf·m/arc min	kgf·m/deg	lb·ft/deg	lb·in/deg
Factor	0.102	2.97 x10 ⁻⁵	1.78x10 ⁻³	0.0129	0.1546

Unit	kgf·m/rad	kgf·m/arc min	kgf·m/deg	lb·ft/deg	lb·in/deg
Factor	9.81	3.37 x10 ⁴	562	77.6	6.47

SI system	N·m/rad
-----------	---------

A-2 Calculating moment of inertia

Formula for moment of inertia and mass

(1) For cases where the center of gravity is coincident with the axis of rotation:

The following table includes formulas to calculate mass and inertia moment.

m : mass (kg), I_x, I_y, I_z: inertia moments which rotates around x-, y-, z-axes respectively (kg·m²)

G : distance from end face of gravity center (m)

ρ : specific gravity

Unit Length: m, Mass: kg, Inertia moment: kg·m²

Apx

Appendix

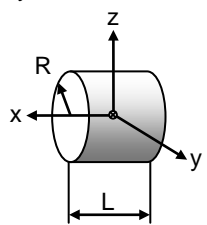
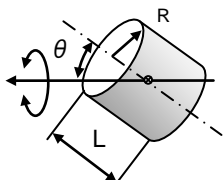
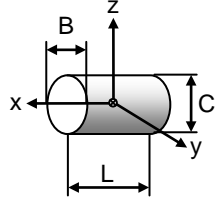
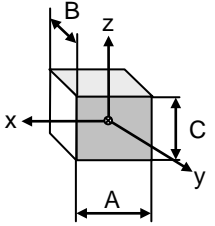
Object form	Mass, inertia, gravity center
	$m = \pi R^2 L \rho$ $I_x = \frac{1}{2} m R^2$ $I_y = \frac{1}{4} m \left(R^2 + \frac{L^2}{3} \right)$ $I_z = \frac{1}{4} m \left(R^2 + \frac{L^2}{3} \right)$
	$m = \pi R^2 L \rho$ $I_{\theta} = \frac{1}{12} m \times \left\{ 3R^2(1 + \cos^2\theta) + L^2 \sin^2\theta \right\}$
	$m = \frac{1}{4} BCL \rho$ $I_x = \frac{1}{16} m (B^2 + C^2)$ $I_y = \frac{1}{4} m \left(\frac{C^2}{4} + \frac{L^2}{3} \right)$ $I_z = \frac{1}{4} m \left(\frac{B^2}{4} + \frac{L^2}{3} \right)$
	$m = ABC \rho$ $I_x = \frac{1}{12} m (B^2 + C^2)$ $I_y = \frac{1}{12} m (C^2 + A^2)$ $I_z = \frac{1}{12} m (A^2 + B^2)$

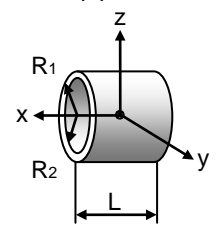
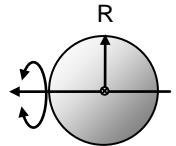
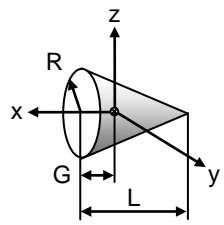
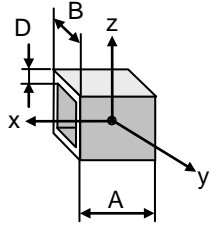
Object form	Mass, inertia, gravity center
	$m = \pi (R_1^2 - R_2^2) L \rho$ $I_x = \frac{1}{2} m (R_1^2 + R_2^2)$ $I_y = \frac{1}{4} m \left\{ (R_1^2 + R_2^2) + \frac{L^2}{3} \right\}$ $I_z = \frac{1}{4} m \left\{ (R_1^2 + R_2^2) + \frac{L^2}{3} \right\}$ <p>R1: Outer diameter R2: Inner diameter</p>
	$m = \frac{4}{3} \pi R^3 \rho$ $I = \frac{2}{5} m R^2$
	$m = \frac{1}{3} \pi R^2 L \rho$ $I_x = \frac{3}{10} m R^2$ $I_y = \frac{3}{80} m (4R^2 + L^2)$ $I_z = \frac{3}{80} m (4R^2 + L^2)$ $G = \frac{L}{4}$
	$m = 4AD(B - D)\rho$ $I_x = \frac{1}{3} m \left\{ (B \cdot D)^2 + D^2 \right\}$ $I_y = \frac{1}{6} m \left\{ \frac{A^2}{2} + (B \cdot D)^2 + D^2 \right\}$ $I_z = \frac{1}{6} m \left\{ \frac{A^2}{2} + (B \cdot D)^2 + D^2 \right\}$

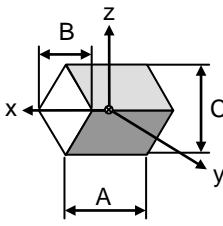
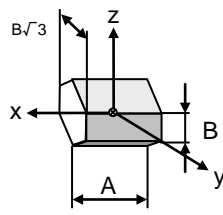
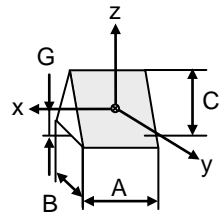
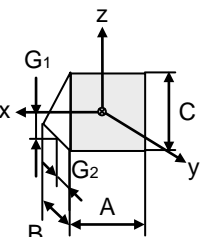
Object form	Mass, inertia, gravity center	Object form	Mass, inertia, gravity center
<p>Rhombus pillar</p> 	$m = \frac{1}{2} ABC\rho$ $I_x = \frac{1}{24} m(B^2 + C^2)$ $I_y = \frac{1}{24} m(C^2 + 2A^2)$ $I_z = \frac{1}{24} m(B^2 + 2A^2)$	<p>Hexagonal pillar</p> 	$m = \frac{3\sqrt{3}}{2} AB^2\rho$ $I_x = \frac{5}{12} mB^2$ $I_y = \frac{1}{12} m\left(A^2 + \frac{5}{2}B^2\right)$ $I_z = \frac{1}{12} m\left(A^2 + \frac{5}{2}B^2\right)$
<p>Isosceles triangle pillar</p> 	$m = \frac{1}{2} ABC\rho$ $I_x = \frac{1}{12} m\left(\frac{B^2}{2} + \frac{2}{3}C^2\right)$ $I_y = \frac{1}{12} m\left(A^2 + \frac{2}{3}C^2\right)$ $I_z = \frac{1}{12} m\left(A^2 + \frac{B^2}{2}\right)$ $G = \frac{C}{3}$	<p>Right triangle pillar</p> 	$m = \frac{1}{2} ABC\rho$ $I_x = \frac{1}{36} m(B^2 + C^2)$ $I_y = \frac{1}{12} m\left(A^2 + \frac{2}{3}C^2\right)$ $I_z = \frac{1}{12} m\left(A^2 + \frac{2}{3}B^2\right)$ $G_1 = \frac{C}{3} \quad G_2 = \frac{B}{3}$

● **Example of specific gravity**

The following tables show references of specific gravity. Confirm the specific gravity for the material of the drive load.

Material	Specific gravity	Material	Specific gravity	Material	Specific gravity
SUS304	7.93	Aluminum	2.70	Epoxy resin	1.90
S45C	7.86	Duralumin	2.80	ABS	1.10
SS400	7.85	Silicon	2.30	Silicon resin	1.80
Cast iron	7.19	Quartz glass	2.20	Polyurethane rubber	1.25
Copper	8.92	Teflon	2.20		
Brass	8.50	Fluorocarbon resin	2.20		

(2) For cases where the center of gravity is not coincident with the axis of rotation:

The following formula calculates the inertia moment when the rotary center is different from the gravity center.

$$I = I_g + mF^2$$

I: Inertia moment when the gravity center axis does not match the rotational axis ($\text{kg}\cdot\text{m}^2$)

I_g : Inertia moment when the gravity center axis matches the rotational axis ($\text{kg}\cdot\text{m}^2$)

Calculate according to the shape by using formula (1).

m: mass (kg)

F: Distance between rotary center and gravity center (m)

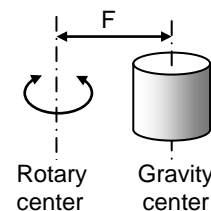

(3) Moment of inertia of an object in linear motion

The inertia moment, converted to actuator axis, of a linear motion object driven by a screw, etc., is calculated using the formula below.

$$I = m\left(\frac{P}{2\pi}\right)^2$$

I: Inertia moment of a linear operation object converted to actuator axis ($\text{kg}\cdot\text{m}^2$)

m: mass (kg)

P: Linear travel per actuator one revolution (m/rev)

Moment of inertia of a cylinder

The inertia moment of a cylinder may be obtained from the graphs to the right.

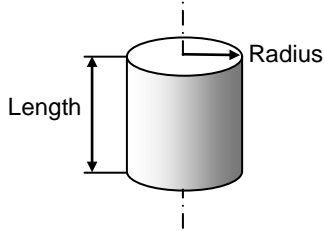

Apply the top graph to aluminum materials (specific gravity: 2.7) and bottom graph to steel materials (specific gravity: 7.85).

(Example)
 Material: Aluminum
 Outer diameter: 100mm
 Length: 7mm
 Shape: Column
 Since the outer diameter is 100mm, the radius is 50mm. Therefore, the above graph gives the inertia moment as follows:
 Approx. $1.9 \times 10^{-4} \text{ kg} \cdot \text{m}^2$
 (Calculated value: $0.000186 \text{ kg} \cdot \text{m}^2$)

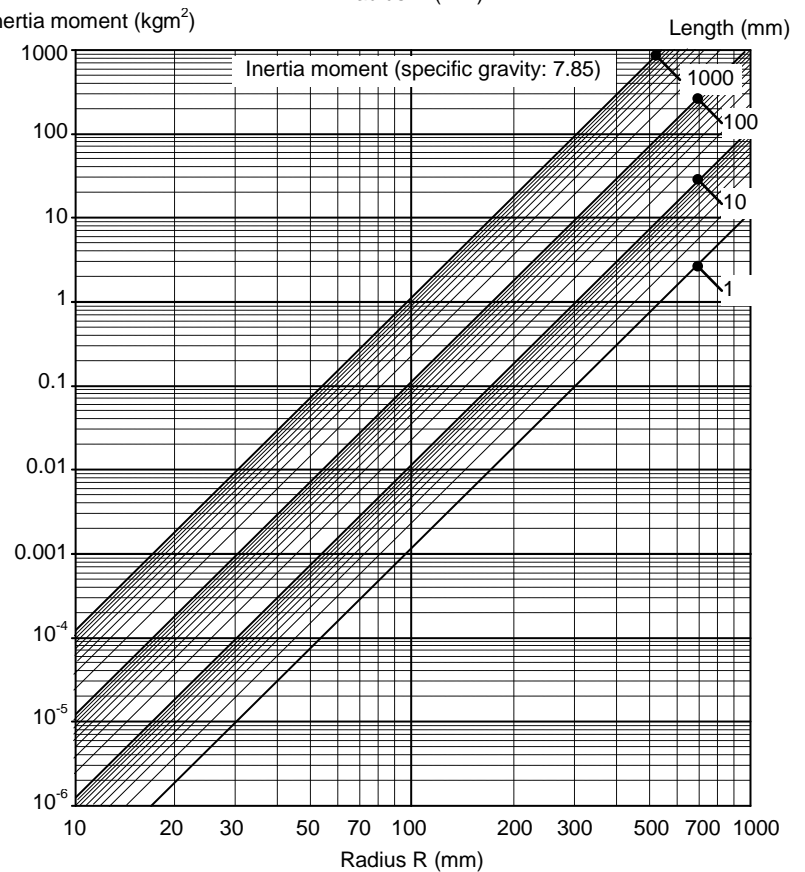
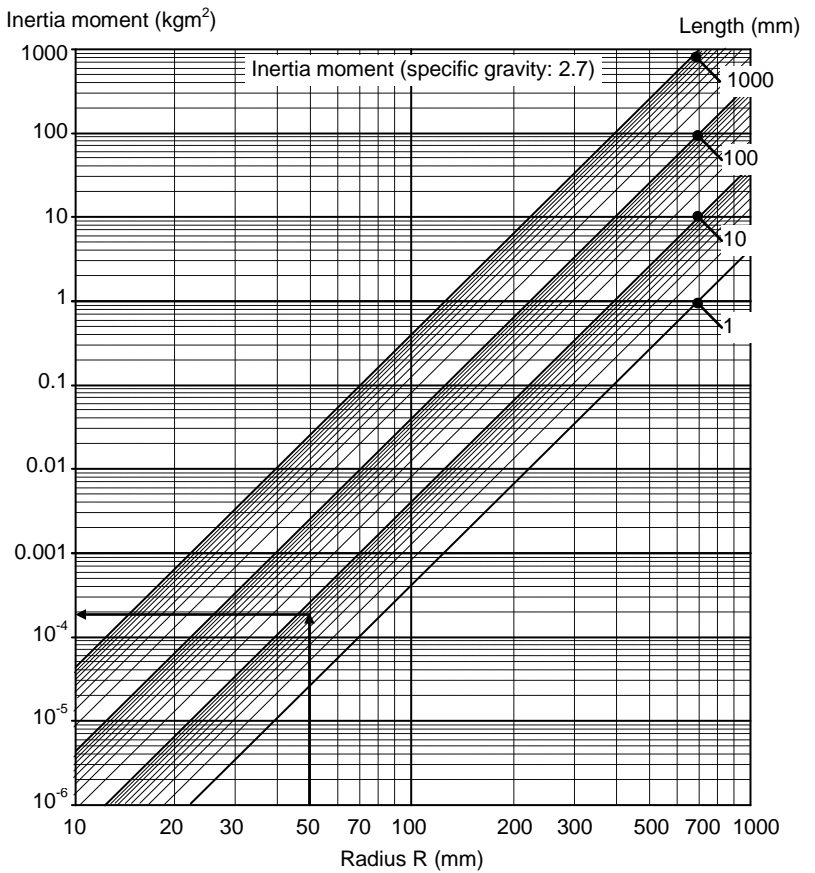

Index

A

Absolute encoder..... 1-21
Acceleration time..... 2-11
Allowable load inertia moment..... 2-1
Average rotation speed..... 2-12

C

Cable specifications..... 1-38
Cable taken out from side..... 4-1
Combinations with drivers and extension cables. 1-3
Conformance to overseas standards..... 7

D

Deceleration time..... 2-11
Detector specifications 1-21

E

Effective torque..... 2-12
Encoder cable specifications 1-39
Environmental conditions..... 3-5
Examining actuator rotation speed 2-9
Examining operating status 2-9
Extension cable 4-2
External dimensions 1-11

I

Inertia moment..... 5-3
Inertia moment of a cylinder 5-5
Installation 3-2, 3-5, 3-6
Installation location 3-5

L

Life..... 2-6
Load inertia moment..... 2-4, 2-9
Load torque 2-10
Load weight 2-5

M

Maximum load moment load..... 2-6
Mechanical accuracy 1-19
Model..... 1-2
Moment stiffness 1-22
Motor cable specifications 1-38
Motor shaft holding brake 1-9

N

Notices on handling..... 3-2

O

One way positional accuracy..... 1-20
Operable range 1-29
Option..... 4-1
Outlines 1-1

P

Positioning pins 3-4
Precautions on installation..... 3-3

R

Receiving inspection..... 3-1
Related manual 7
Resistance to vibration 1-28
Rigidity..... 1-22
Rotation direction..... 1-26

S

SHA series selection..... 2-1
Shock resistance 1-27
Specifications 1-4
Static safety coefficient..... 2-8
Surface treatment..... 3-4

T

Torsional stiffness..... 1-23, 1-25
Transmission torque 3-2

U

Unit..... 5-1

W

With near origin and end limit sensors..... 4-1

Warranty Period and Terms

The equipment listed in this document is warranted as follows:

■Warranty period

Under the condition that the actuator are handled, used and maintained properly followed each item of the documents and the manuals, all the applicable products are warranted against defects in workmanship and materials for the shorter period of either one year after delivery or 2,000 hours of operation time.

■Warranty terms

All the applicable products are warranted against defects in workmanship and materials for the warranted period. This limited warranty does not apply to any product that has been subject to:

- (1) user's misapplication, improper installation, inadequate maintenance, or misuse.
- (2) disassembling, modification or repair by others than Harmonic Drive Systems, Inc.
- (3) imperfection caused by a non-applicable product.
- (4) disaster or others that does not belong to the responsibility of Harmonic Drive Systems, Inc.

Our liability shall be limited exclusively to repairing or replacing the product only found by Harmonic Drive Systems, Inc. to be defective. Harmonic Drive Systems, Inc. shall not be liable for consequential damages of other equipment caused by the defective products, and shall not be liable for the incidental and consequential expenses and the labor costs for detaching and installing to the driven equipment.



Registered Trademark in Japan

Certified to ISO14001 (HOTAKA Plant) / ISO9001 (TÜV Management Service GmbH)
 All specifications and dimensions in this manual subject to change without notice.
 This manual is correct as of June 2014.

	Head Office / Believe Omori 7F 6-25-3Minami-Ohi, Shinagawa-ku, Tokyo, Japan 〒140-0013 TEL+81(0)3-5471-7800 FAX+81(0)3-5471-7811 Overseas Division / 1856-1 Hotakamaki Azumino-shi Nagano, Japan 〒399-8305 TEL+81(0)263-83-6935 FAX+81(0)263-83-6901 HOTAKA Plant / 1856-1 Hotakamaki Azumino-shi Nagano, Japan 〒399-8305 TEL+81(0)263-83-6800 FAX+81(0)263-83-6901 Harmonic Drive AG / Hoenbergstraße 14, 65555 Limburg, Germany TEL06431-5008-0 FAX06431-5008-18 Harmonic Drive L.L.C / 247 Lynnfield Street, Peabody, MA, 01960, U.S.A. TEL+1- 978-532-1800 FAX+1- 978-532-9406
--	--

*HarmonicDrive® is a trademark of Harmonic Drive Systems, Inc.
 The academic or general nomenclature of our products "HarmonicDrive®" is "strain wave gearing."
 The trademark is registered in Japan, Korea and Taiwan.

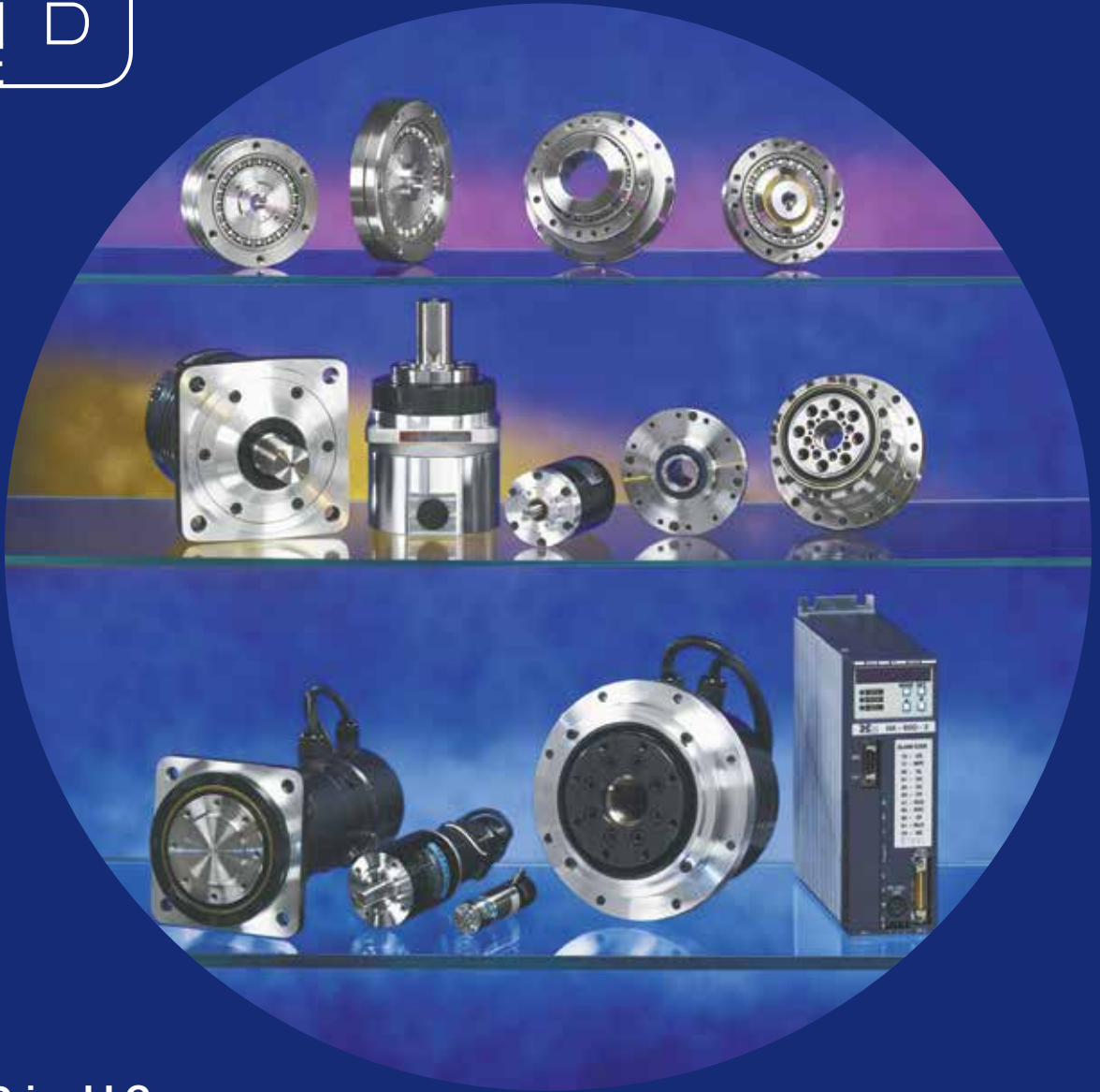

Harmonic Drive LLC

Boston US Headquarters
247 Lynnfield Street
Peabody, MA 01960

New York Sales Office
100 Motor Parkway
Suite 116
Hauppauge, NY 11788

California Sales Office
333 W. San Carlos Street
Suite 1070
San Jose, CA 95110

Chicago Sales Office
137 N. Oak Park Ave., Suite 410
Oak Park, IL 60301

T: 800.921.3332
T: 978.532.1800
F: 978.532.9406

www.HarmonicDrive.net

Group Companies

Harmonic Drive Systems, Inc.
6-25-3 Minami-Ohi, Shinagawa-ku
Tokyo 141-0013, Japan

Harmonic Drive AG
Hoenbergstrasse, 14, D-6555
Limburg/Lahn Germany

