

Rating Table

1. Ratio	30	50	100
2. Rated Torque at 2000 rpm	2.2 Nm	3.5 Nm	5.0 Nm
3. Limit for Repeated Peak Torque	4.5 Nm	8.3 Nm	11 Nm
4. Limit for Average Torque	3.4 Nm	5.5 Nm	8.9 Nm
5. Limit for Momentary Peak Torque	8.5 Nm	17 Nm	25 Nm
6. Max. Input Speed rpm	8500 r/min	8500 r/min	8500 r/min
7. Limit for Average Input Speed rpm	3500 r/min	3500 r/min	3500 r/min

Performance Date for the Output Bearing

Pitch Circle	Offset	Dynamic Load Rating C	Static Load Rating Co	Permissible Dynamic Tilting Moment	Tilting Moment Stiffness	Permissible Dynamic Radial Load	Permissible Dynamic Axial Load
27.5 mm	9 mm	3.89x10 <sup>3</sup> N	3.54x10 <sup>3</sup> N	6.6 Nm	7.41x10 <sup>3</sup> Nm/rad	300 N	1150 N

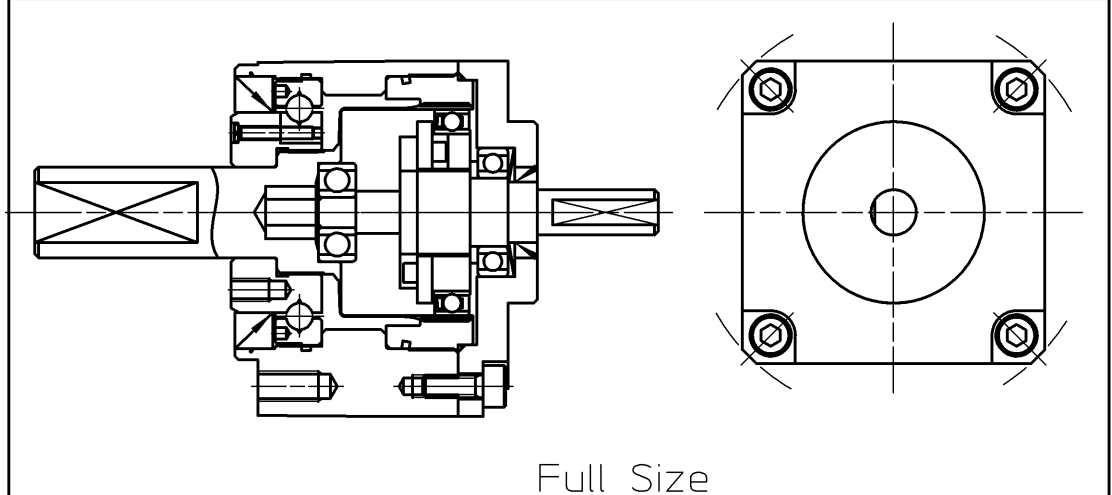

**PROPRIETORSHIP**  
 This drawing (document) is the **PROPERTY** of Harmonic Drive Systems, Inc. and shall not be traced, otherwise copied or used for purposes other than agreed upon, nor communicated to any third party without written permission of Harmonic Drive Systems, Inc.

REMARKS  
 Lubrication : Harmonic Drive Harmonic Grease SK-2  
 Output Bearing Multemp HL-D  
 ※ Please remark that there is no position relationship between 6-M3 and keyway.  
 Designing and/or Handling of Harmonic Drive Gears(Harmonic Actuators)  
 has to Comply with technical information shown in Harmonic Drive Catalog

CUSTOMER DRAWING NO.

訂正 REV	来歴 DESCRIPTION	仕様 SPEC	(標準)	40-6419A01	尺度 SCALE	1.5:1	設計 DESIGN	K.SHIRASAWA Jul- 4-07	タイトル TITLE	ASSEMBLY DRAWING
機械加工 無記号公差 GENERAL TOLERANCE	備考 REMARKS	0 0.5 0.5	0.5 6 30	0.5 30 120	0.5 30 120	0.5 30 120	0.5 30 120	0.5 30 120	0.5 30 120	0.5 30 120
0.05 ±0.05	特記無き角はCO. 2以下、すみの丸みはRO. 4以下 無記号表面アブラサ SURFACES MARKED EXCEPT AS NOTED	±0.1 ±0.1	±0.2 ±0.2	±0.3 ±0.3	±0.5 ±0.5	±0.8 ±0.8	±1.2 ±1.2	50S ▽→▽	25S ▽▽→▽▽	6.3S ▽▽▽→▽▽▽
本図は (株) ハーモニック・ドライブ・システムズの所有に係わるものです。許可なく第三者に見せたり、トレースその他の複写及び指定された用途以外には使用しないで下さい。							DWG SIZE <b>A3</b>		UNIT mm	THIRD ANG 
HARMONIC DRIVE SYSTEMS INC. TOKYO JAPAN								検図 VRFD E.KIDOOKA Jul- 4-07	製品名 ARTICLE CSF-11-XXX-1U	
本図は (株) ハーモニック・ドライブ・システムズの所有に係わるものです。許可なく第三者に見せたり、トレースその他の複写及び指定された用途以外には使用しないで下さい。								承認 APPD E.KIDOOKA Jul- 4-07	図番 DWG No C2A0038 -	