

ITEM	QTY	PART
1	1	FLEXSPLINE
2	1	CIRCULAR SPLINE
3	1	WAVE GENERATOR ASSEMBLY

REVISIONS					
REV	DCF NO.	BY	CHKD	APPD	DATE
A	ER12-105	WTH	RELEASED		5/2/13
B	14-124	WTH	AAF		5/19/2014
C	20-0742	NAN	MAG	AMM	1/12/2021

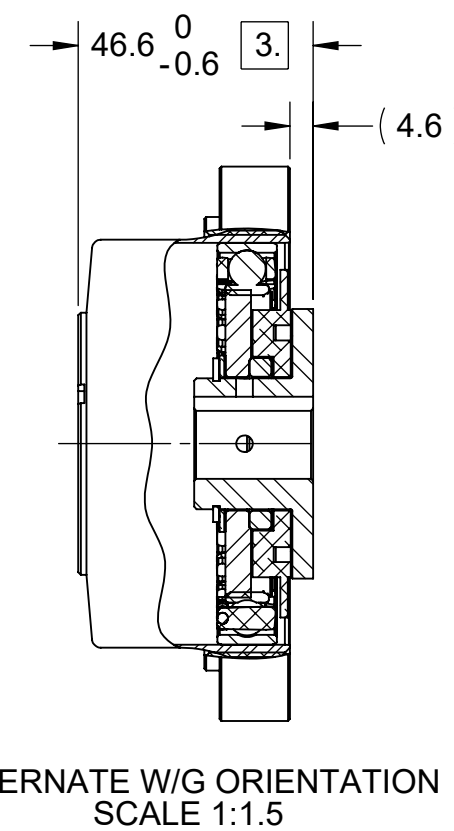
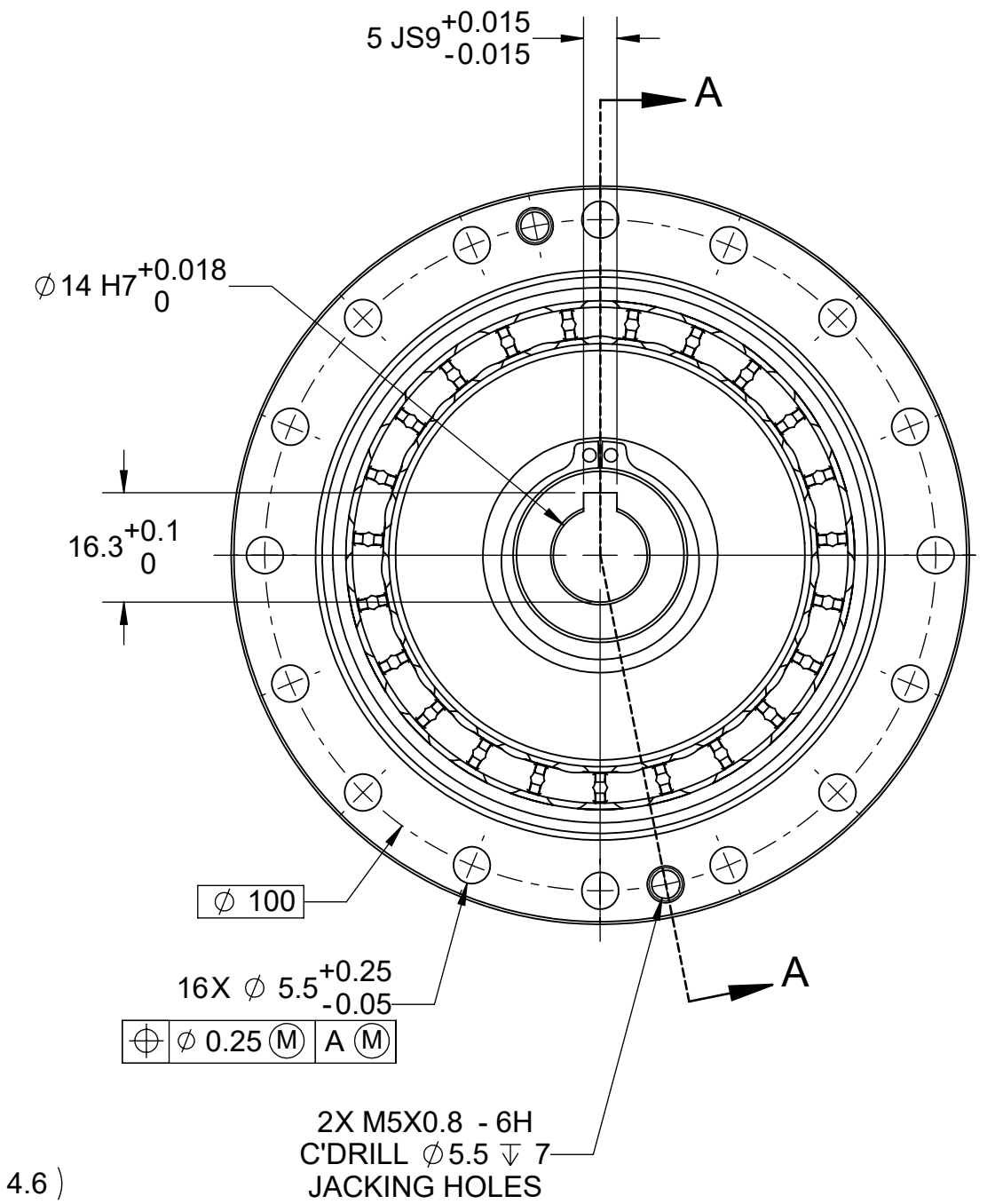
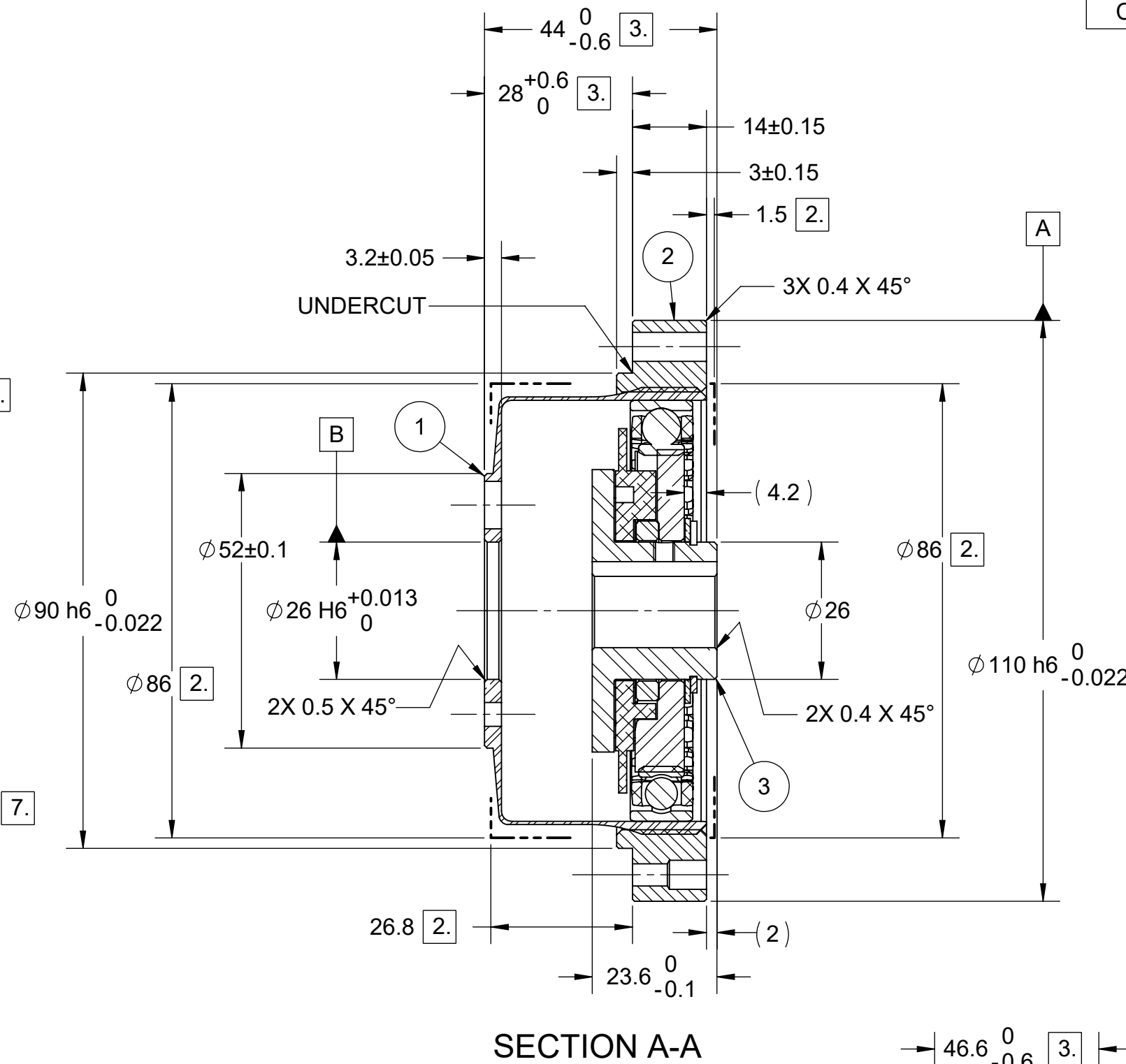
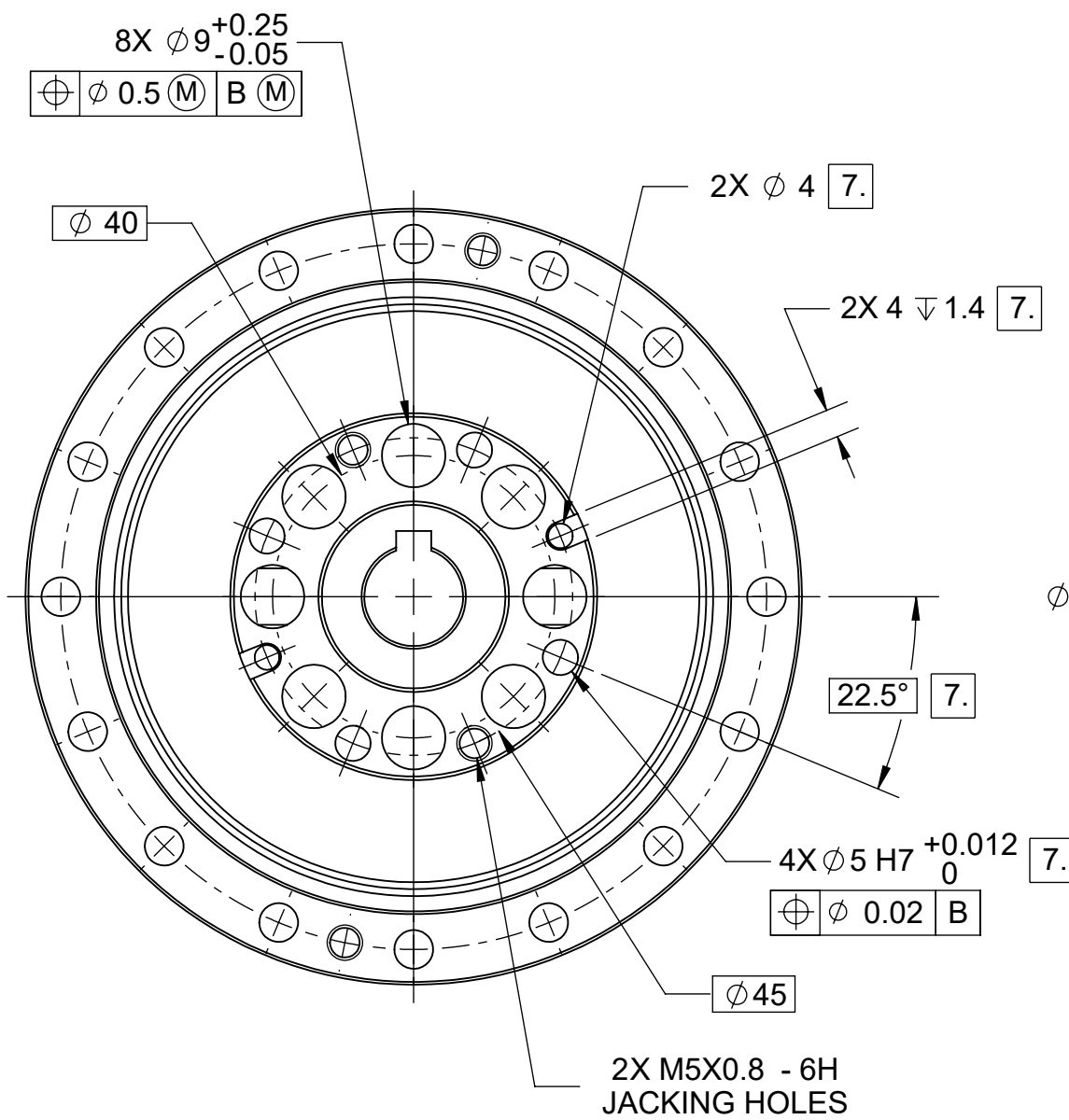

NOTES:

- DESIGN AND/OR HANDLING OF HARMONIC DRIVE PRODUCTS MUST BE IN COMPLIANCE WITH TECHNICAL INFORMATION FOUND IN HARMONIC DRIVE CATALOGS AT: WWW.HARMONICDRIVE.NET/DOWNLOADS/CATALOGS
- MINIMUM HOUSING CLEARANCE.
- DIMENSIONS ESTABLISH INTERFACE AND INSTALLATION REQUIREMENTS. MAINTAIN AT ASSEMBLY AND UNDER ALL OPERATING LOAD CONDITIONS.
- ALL CIRCULAR HOLE PATTERNS ARE EQUALLY SPACED UNLESS OTHERWISE SPECIFIED.
- MAINTAIN COMPONENTS IN "AS RECEIVED" SERIALIZED SETS.
- CONFIGURATION IS FOR GREASE LUBRICATION ONLY. CONTACT HDLLC IF OIL LUBRICATION IS DESIRED.
- CONFIGURATION OPTIONS PER TABLE. TO ORDER USE PART NUMBER AND DESCRIPTION FROM TABLE.

CONFIGURATION TABLE		
PART NUMBER	DESCRIPTION	FEATURE
34-032XXXUS	CSG-32-XXX-2A-GR	STANDARD
34-032XXXAUS	CSG-32-XXX-2A-GR-IV	OIL HOLES
34-032XXXBUS	CSG-32-XXX-2A-GR-B	DOWEL HOLES
34-032XXXCUS	CSG-32-XXX-2A-GR-C	OIL AND DOWEL HOLES

PROPRIETARY AND CONFIDENTIAL
 THIS DRAWING CONTAINS VALUABLE CONFIDENTIAL AND PROPRIETARY TRADE SECRET INFORMATION OF HARMONIC DRIVE LLC. COPYING, DISCLOSING, OR USING THIS INFORMATION WITHOUT THE EXPRESS WRITTEN AUTHORIZATION OF HARMONIC DRIVE LLC IS PROHIBITED.

THIRD ANGLE

THIS DOCUMENT WAS CREATED IN ACCORDANCE WITH ASME Y14.5-2018.

DIMENSIONS ARE IN MILLIMETERS UNLESS OTHERWISE SPECIFIED.

DRAFTER WTH 8/23/12	CHECKER RWC 9/12/12
MAT'L ENG. THB 5/2/13	DESIGN ENG.
MFG. ENG. CDM 5/2/13	QUALITY
SIMILAR TO	



HarmonicDrive®
 42 DUNHAM RIDGE
 BEVERLY MA 01915-1844
www.harmonicdrive.net

TITLE:
INSTALLATION DRAWING
CSG-32-XXX-2A-GR

SIZE C	CAGE CODE 34519	DWG. NO. 1010906	REV C
SCALE: 1:1			SHEET 1 OF 1