

D C S e r v o S y s t e m s

RH Mini Series



Total Motion Control

Harmonic Drive® actuator

P r e c i s i o n G e a r i n g & M o t i o n C o n t r o l

Precision Gearing & Motion Control

DC SERVO ACTUATORS

FEATURES: • ZERO BACKLASH • HIGH POSITIONAL ACCURACY • HIGH STIFFNESS



The RH mini series actuators are used in highly demanding industrial servo systems and provide precision motion control and high torque capacity in very compact packages.

Select the optimum DC servo actuator

The RH actuators combining precision Harmonic Drive® gear and DC servo motors offer unique features unsurpassed by conventionally geared drives. Used in highly demanding industrial servo systems, they provide precision motion control and high torque capacity in very compact packages. The tach-generator and/or encoder are directly mounted onto the motor shaft. Since the gear has zero backlash, high servo gains may be used, providing a very stiff, yet stable servo system.

The Harmonic Drive® gear is lubricated with a specially developed grease to ensure minimum maintenance requirements and long service life. The motor brush holders have seals to prevent dust transfer.

Contents

Selection Procedure	4
RH Mini Series DC Servo Actuators	6
Technical Data	6
Performance Curves	7
Duty Cycle Characteristics	8
Loading Curves	8
Motor	9
Tach-Generator	9
Encoder	10
Weights	11
Output Shaft Tolerances	11
Dimensions	12
Ordering Code	16

Selection Procedure

Requirements for Preliminary Selection

- Load Torque T_L [Nm] < Rated Torque T_N [Nm]
- Load Speed n_L [rpm] < Rated Output Speed n_N [rpm]
- Load Inertia J_L [kgm²] < 3 J_A (Actuator Inertia) acceptable
- Load Inertia J_L [kgm²] < J_A (Actuator Inertia) for best possible dynamic response

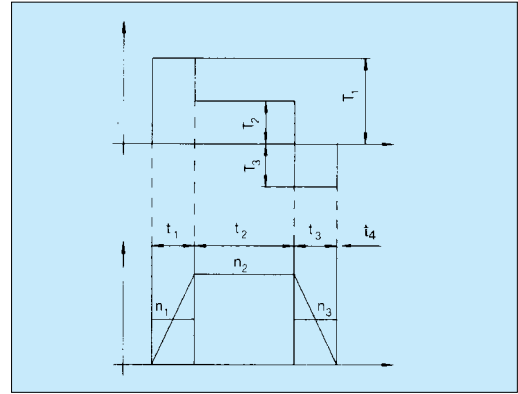

Determination of the duty cycle

Preliminary selection of the actuator

Determination of the acceleration torque T_1 [Nm]

$$T_1 = T_L + \frac{2\pi}{60} \cdot \frac{(J_A + J_L) \cdot n_L}{t_1}$$

[Equation 1]

Acceleration Torque T_1 < Maximum Output Torque T_m
(Values for T_m see page 8, 18, and 19)

No

Select another actuator which meets this requirement

Determination of the average torque T_A [Nm]

$$T_A = \sqrt{\frac{T_1^2 \cdot t_1 + T_2^2 \cdot t_2 + T_3^2 \cdot t_3}{t_1 + t_2 + t_3 + t_4}}$$

with: T_1 = Acceleration Torque
 T_2 = T_L = Load Torque
 T_3 = $T_2 - (T_1 - T_2)$ Braking Torque
 (if $t_1 = t_3$)

[Equation 2]

Average Torque T_A < Rated Torque T_N of the actuator
(Values for T_N see page 8, 18 and 19)

No

Select another actuator which meets this requirement

Selected actuator meets all requirements

Select the required encoder resolution

Position Control required

Speed Control required

Encoder Resolution Where: n = Encoder Resolution
 R = Gear reduction ratio
 θ_A = Desired position accuracy at the output [arc-min]
 γ = Encoder multiplier

$$n \geq (5-10) \cdot \frac{60 \cdot 360}{\theta_A \cdot R \cdot \gamma}$$

[Equation 3]

Encoder Resolution Where: n_{min} = Minimum operating output speed [rpm]
 f_s = Cut-off frequency [Hz]

$$n \geq 3 \cdot \frac{60 \cdot f_s}{n_{min} \cdot R \cdot \gamma}$$

[Equation 4]

For HS Series Control Units the cut-off frequency f_s can be assumed to be 100 Hz.

Selection of Encoder Output Type

The most suitable encoder output type can be selected according to the following basic specifications:

- ◆ AL - Line Driver (+5V version)
This type can transmit the encoder signal up to 10m and requires a 5V DC power supply
- ◆ BL - Line Driver (+12V version)
This type can transmit the encoder signal up to 100m and requires a 12V DC power supply
- ◆ DO - Open Collector (+ 4.75V to 12.6V); AO - Open Collector (+5V)
These types can transmit the encoder signal up to 10m. They should not be used in environments suffering from high levels of electrical noise.

Example



Load and Operating Conditions		Actuator Data
Load Torque	$T_L = 5 \text{ Nm}$	$< T_N = 5.9 \text{ Nm}$
Load Speed	$n_L = 20 \text{ rpm}$	$< n_N = 30 \text{ rpm}$
Load Inertia	$J_L = 0.15 \text{ kgm}^2$	$< J_A = 0.0816 \text{ kgm}^2$
Acceleration Time	$t_1 = 0.1 \text{ s}$	$< T_m = 20 \text{ Nm}$
Constant Speed Time	$t_2 = 0.2 \text{ s}$	
Braking Time	$t_3 = 0.1 \text{ s}$	
Idle Time	$t_4 = 0.6 \text{ s}$	

Preliminary Selection: RH - 14D - 3002

Determination of the acceleration torque T_1

$$T_1 = 5 \text{ Nm} + \frac{2\pi}{60} \cdot \frac{(0.15 \text{ kgm}^2 + 0.0816 \text{ kgm}^2) \cdot 20 \text{ rpm}}{0.1 \text{ s}} = 9.85 \text{ Nm}$$

Acceleration Torque $T_1 = 9.85 \text{ Nm} < \text{Maximum Output Torque of the actuator } T_m = 20 \text{ Nm}$

Determination of the average torque T_A

$$T_A = \sqrt{\frac{(9.85 \text{ Nm})^2 \cdot 0.1 \text{ s} + (5 \text{ Nm})^2 \cdot 0.2 \text{ s} + (0.15 \text{ Nm})^2 \cdot 0.1 \text{ s}}{0.1 \text{ s} + 0.2 \text{ s} + 0.1 \text{ s} + 0.6 \text{ s}}} = 3.83 \text{ Nm}$$

with:

$$T_1 = 9.85 \text{ Nm}$$

$$T_2 = T_L = 5 \text{ Nm}$$

$$T_3 = 5 \text{ Nm} - (9.85 \text{ Nm} - 5 \text{ Nm}) = 0.15 \text{ Nm}$$

Average Torque $T_A = 3.83 \text{ Nm} < \text{Rated Torque of the actuator } T_N = 5.9 \text{ Nm}$

Selected servo actuator: RH - 14D - 3002

Selection of the necessary encoder resolution (length between actuator and control unit $\leq 10 \text{ m}$)

Position Control required

Encoder Resolution

with: $R = 100$
 $\theta = 1 \text{ arcmin}$
 $\gamma = 4$

$$n \geq 5 \cdot \frac{21600}{1 \cdot 100 \cdot 4} = 270 \text{ ppr}$$

Speed Control required

Encoder Resolution

with: $R = 50$
 $n_{\min} = 0.5 \text{ rpm}$
 $f_s = 100 \text{ Hz}$

$$n \geq 3 \cdot \frac{60 \cdot 100}{0.5 \cdot 50 \cdot 4} = 180 \text{ ppr}$$

The distance between the actuator and the control unit is less than 10 m. Therefore a line driver output is recommended (AL-Type).

Selection:

The above procedure leads to the following selection

Actuator RH - 14D - 3002 - E050AL

RH Mini Series DC Servo Actuators

Technical Data

Rating:	Continuous
Excitation device:	RE Permanent magnet
Insulation:	Class B
Insulation voltage:	AC 500V, one minute
Insulation resistance:	100MΩ or more (DC 500V Megger)

Vibration:	2.5 g (5 . . . 400 Hz)
Shock:	< 30 g (11 ms)
Construction:	Totally enclosed
Lubrication:	Grease (SK-2)
Ambient temperature:	0 ~ 40°C
Ambient humidity:	20 ~ 80% (non condensing)

Item	Actuator	RH-5A			RH-8D		RH-11D		RH-14D	
		8002	5502	4402	6006	3006	6001	3001	6002	3002
Rated Output Power ¹⁾	W	1.5	1.7	1.4	8.6	6.2	13.6	12.3	20.3	18.5
Rated Voltage ¹⁾	V	12	12	12	24	24	24	24	24	24
Rated Current ¹⁾	A	0.5	0.5	0.5	1.0	0.8	1.3	1.3	1.8	1.8
Rated Output Torque ¹⁾ T _N	in-lb	1.4	2.6	2.6	12	17	19	34	28	52
	Nm	0.16	0.29	0.29	1.4	2.0	2.2	3.9	3.2	5.9
Rated Output Speed ¹⁾ n _N	rpm	88	55	44	60	30	60	30	60	30
Max. Continuous Stall Torque ¹⁾²⁾	in-lb	2.1	3.5	3.8	13	20	22	39	48	69
	Nm	0.24	0.39	0.43	1.5	2.3	2.5	4.4	5.4	7.8
Peak Current ¹⁾²⁾	A	0.83	0.78	0.77	1.6	1.1	2.4	2.1	5.4	4.1
Maximum Output Torque ¹⁾²⁾ T _m	in-lb	3.5	5.2	6.1	24	31	43	69	122	174
	Nm	0.39	0.59	0.69	2.7	3.5	4.9	7.8	14	20
Maximum Output Speed ¹⁾	rpm	180	110	90	100	50	100	50	100	50
Torque Constant	in-lb/A	6	10	12	19	37	22	43	26	51
	Nm/A	0.69	1.11	1.38	2.10	4.20	2.46	4.91	2.92	5.76
Voltage Constant (B.E.M.F.)	V/rpm	0.08	0.12	0.15	0.22	0.44	0.26	0.50	0.30	0.60
Inertia at Output Shaft ³⁾	in-lb-sec ²	0.006	0.014	0.022	0.033	0.13	0.095	0.38	0.18	0.72
	kgm ² x10 ³	0.63	1.6	2.5	3.7	15.0	11.0	43.0	21.6	81.6
Mechanical Time Constant	msec	13.3	13.3	13.3	8.5	8.5	8.5	8.5	7.0	7.0
Rated Power Rate ¹⁾	kW/sec	0.039	0.055	0.034	0.51	0.26	0.43	0.36	0.51	0.42
Thermal Time Constant ¹⁾	min	5.2	5.2	5.2	9	9	10	10	11	11
Thermal Resistance ¹⁾	°C/W	11.4	11.4	11.4	4.2	4.2	3.3	3.3	2.8	2.8
Gear Ratio	1:R	1:50	1:80	1:100	50	100	50	100	50	100
Maximum Radial Load ⁶⁾	lb	13	13	13	44	44	55	55	88	88
	N	59	59	59	196	196	245	245	392	392
Maximum Axial Load	lb	7	7	7	22	22	44	44	88	88
	N	29	29	29	98	98	196	196	392	392
Motor Rated Output ¹⁾⁵⁾	W	(2.6)	(2.6)	(2.6)	(10)	(10)	(20)	(20)	(30)	(30)
Motor Rated Speed ¹⁾	rpm	4500	4500	4500	3000	3000	3000	3000	3000	3000
Armature Resistance	Ω	8.6	8.6	8.6	10	10	4.7	4.7	2.7	2.7
Armature Inductance	mH	2.7	2.7	2.7	2.2	2.2	1.6	1.6	1.1	1.1
Electrical Time Constant	ms	0.31	0.31	0.31	0.22	0.22	0.34	0.34	0.41	0.41
No-Load Running Current ⁴⁾	A	0.27	0.24	0.28	0.38	0.36	0.61	0.55	0.89	0.91
Actuator Accuracy	arc-min	4.5	4.5	4.5	2.5	2.5	2.0	2.0	2.0	2.0
Actuator Repeatability	arc-sec	±90	±90	±90	±60	±60	±60	±60	±60	±60
Servo Drive Combinations	DC 20V	DCJ-055-09, DDP-090-09, DEP-090-09			–	–	–	–	–	–
	DC 24V	–			DCJ-055-09, DDP-090-09, DEP-090-09		DCJ-055-09, DDP-090-09, DEP-090-09		DCJ-055-09, DDP-090-09, DEP-090-09	
	AC 100V	HS-360-1A			HS-360-1B		HS-360-1C		HS-360-1D	

Table 2

Additional information

* Actuator specifications show output characteristics, including gear efficiency.

* All specifications are applicable for actuators mounted on aluminum heat sink of the following sizes:

RH-5: 100 x 100 x 3 mm,

RH-8, 11, 14: 150 x 150 x 6 mm.

Please Note:

¹⁾ The values are for saturated actuator temperature. Other values (not marked with ¹⁾) are for actuator temperature of 20°C.

²⁾ The values given represent an upper limit and actual load values should be lower.

³⁾ The tabulated value is the moment of inertia reflected to the output shaft resulting from the sum of the motor inertia and the gear inertia.

⁴⁾ Values are for rated output speed.

⁵⁾ Values are for reference only.

⁶⁾ Cantilevered load applied at the midpoint of the shaft extension.

Performance Curves

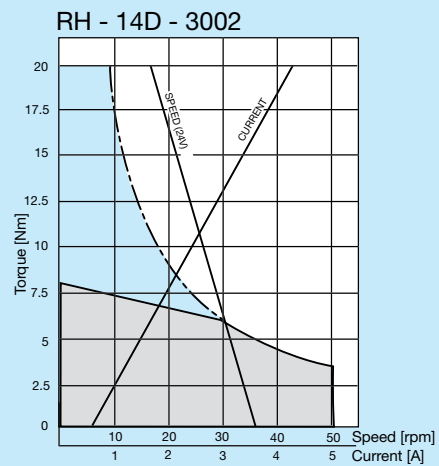
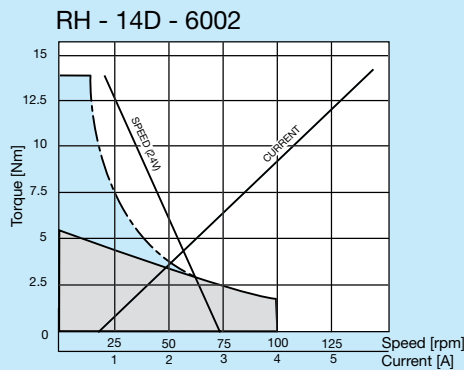
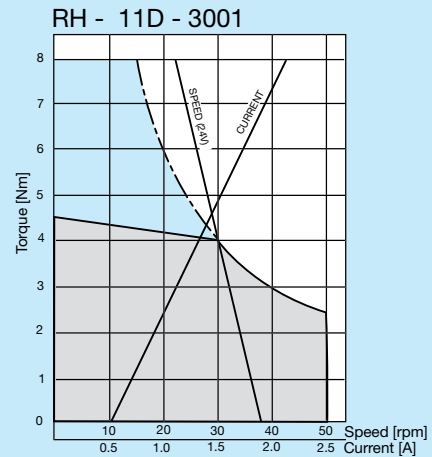
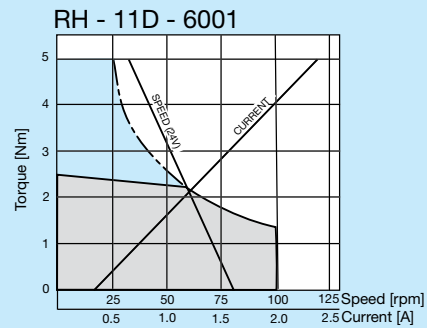
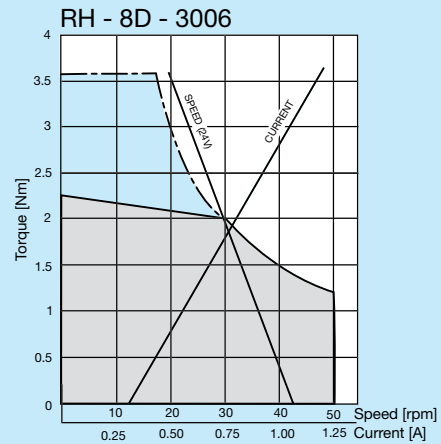
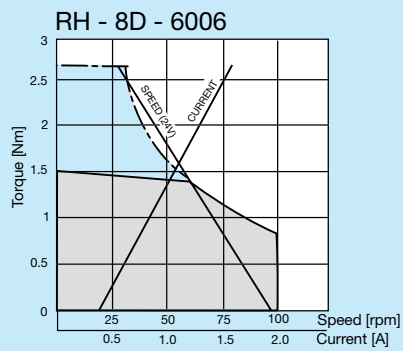
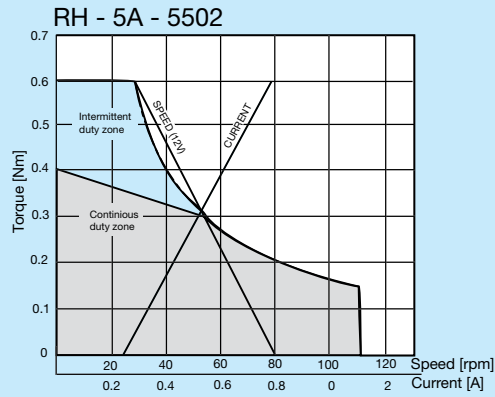

Duty Cycle Characteristics

When an actuator is repeatedly operated above the rated torque and speed for periods of 0.1 minute or more, the minimum idle time required to prevent damage from overheating can be calculated from the graphs on this page once the load factor and the duty factor have been established.

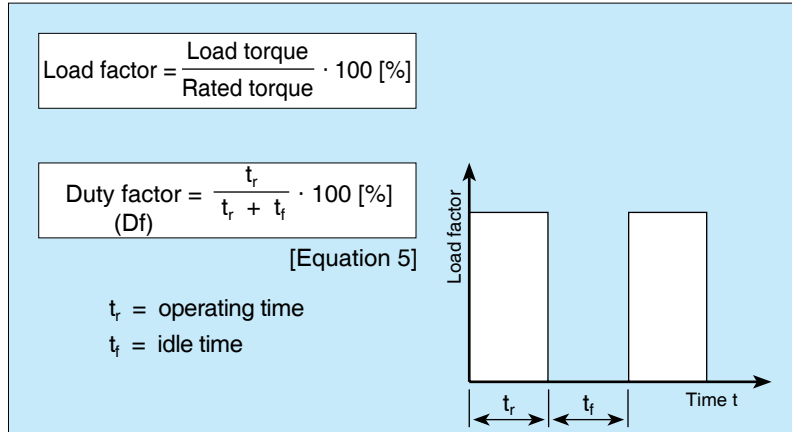

Calculation example: RH-14D-6002 actuator

For a given load factor of 150% and duty factor of 30% a permissible operating time $t_r = 4$ minutes can be read from the curve. For a duty factor of 30% this means that an idle time $t_i = 9.3$ minutes is required between operations.

$$\frac{t_r}{t_r + t_i} \cdot 100 \% = 30\%$$

$$t_i = \frac{t_r}{Df} - t_r = \frac{4}{.3} - 4 = 9.3 \text{ minutes}$$

Loading Curves

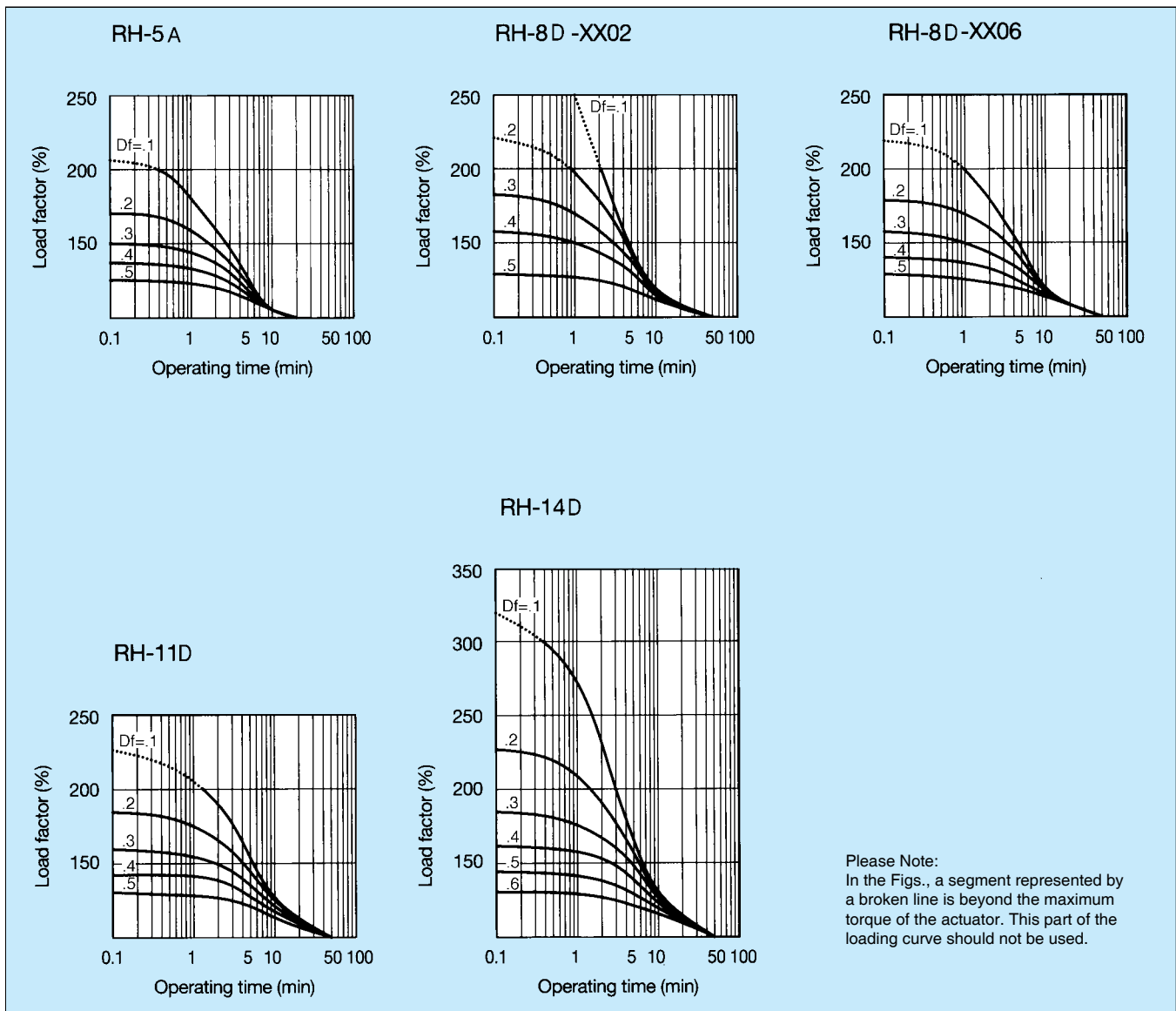

Motor

Polarity

The output shaft rotation is clockwise (when viewed from the output shaft of the actuator), when the voltage applied to the white motor lead is positive with respect to the black lead.

Motor Lead Wires

Table 3

Actuator	Wire	
	length (m)	c. s. area (mm ²)
RH-5A	0.3	0.08
RH-8D	0.6	0.4
RH-11D	0.6	0.4
RH-14D	0.6	0.4

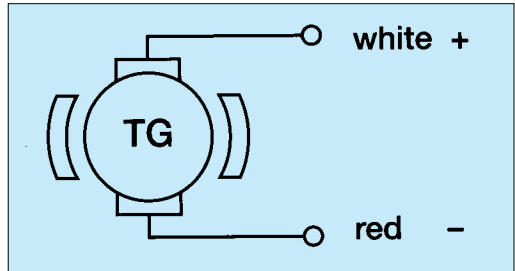
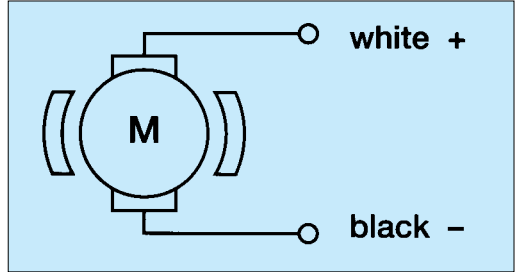

Tach-Generator

For the Mini Series RH-8D, RH-11D and RH-14D, a DC tach- generator is available as an option. The specification of the tach- generator is given in the table below.

Table 4

Output voltage	3 V \pm 10% / 1000 rpm
Ripple (RMS) ¹⁾	1% (200~5000 rpm)
Ripple (peak to peak) ¹⁾	3% (200~5000 rpm)
Linearity ¹⁾	1% (200~5000 rpm)
Direction deviation	1% (200~5000 rpm)
Temperature coefficient	< 0.02% / °C
Moment of Inertia ²⁾	1.2 x 10 ⁻⁶
Armature resistance	45 Ω \pm 10% (at 20 °C)
Armature inductance	7 mH \pm 20%
Maximum rotation speed	5000 rpm
Friction torque	< 4 x 10 ⁻³ Nm
Minimum load resistance	10 k Ω
Insulation resistance	100 M Ω (DC 500 V Megger)
Breakdown voltage	AC 500 V / 1 minute
Weight	0.08 kg

Please note:

- ¹⁾ This value refers to the tach-generator only.
- ²⁾ This value is referred to the motor shaft. For the moment of inertia referred to the actuator output shaft multiply this value by the square of the reduction ratio.

Tach-Generator Lead Wires

heat resistant vinyl wire (0.4 mm²)

Table 5

Actuator	Wire	
	length (m)	c. s. area (mm ²)
RH-8D	0.6	0.4
RH-11D	0.6	0.4
RH-14D	0.6	0.4

Polarity

When the rotation is clockwise viewed from the output shaft, white is positive, and red is negative.

Testing Circuit for Output Voltage, Linearity and Ripple:

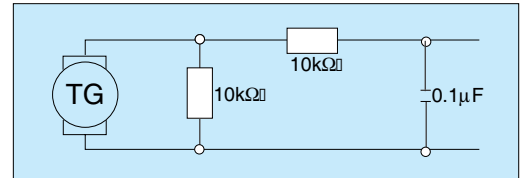

Type		RH-5A		RH-8D, RH-11D, RH-14D					
Output Circuit		Open Collector AO	Line Driver AL	Open Collector DO		Line Driver AL BL			
Power Supply ²⁾	VDC	+5	±5%	+4.75 ~ +12.6		+5 ±5%	+7 ~ +12.6		
	mA	60 max.	170 max.	60 max.		170 max.			
Output Voltage V_{OL}, V_{OH}	V	0.5 max., -	0.5max., 2.5 in.	0.5 max., -		0.5 max., 2.5 min.			
Max. Response Frequency	kHz	100		125		125			
Resolution ¹⁾	P/rev	200	360	500	200	360	500	1000	
Output Signal		A, B, Z	A, A, B, B, Z, Z		A, B, Z		A, A, B, B, Z, Z		
Max. Voltage V_{CC}	VDC	36		-		36		-	
Max. Current I_{OL}	A	20 max.		20 max.		20 max.		20 max.	
Moment of Inertia ³⁾	kgm ²	2 x 10 ⁻⁹		3 x 10 ⁻⁸		3 x 10 ⁻⁸		3 x 10 ⁻⁸	
Lead Wire	mm	Ø 3 x 300L Ø 0.08/7 Strand		Ø 4 x 600L Ø 0.12/7 Strand		Ø 4 x 600L Ø 0.12/7 Strand		Ø 4 x 600L Ø 0.12/7 Strand	

Please note:

¹⁾ Resolution of encoder only. Resolution at the output of the actuator is equal to the encoder resolution multiplied by the reduction ratio.

²⁾ 12 V DC is recommended in case of cable length longer than 10 m (5 V for AL-type, 12 V for BL-type).

³⁾ Moment of inertia referred to the motor shaft.

RH-5A Open Collector AO

● Output Circuit

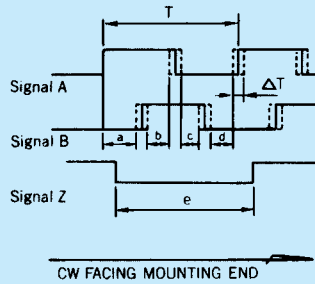
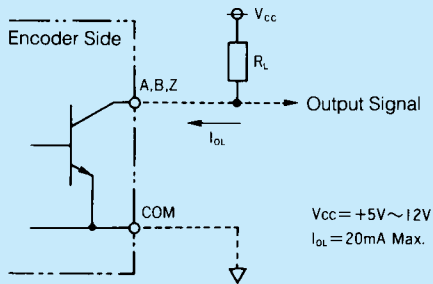

T = Average cycle
a, b, c, d = 0.25T ± 0.1
e = 0.5T ± 0.1
ΔT ≤ 0.1T

RH-8D /11D /14D Line Driver

● Output Circuit

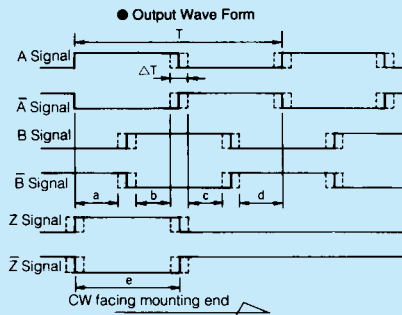
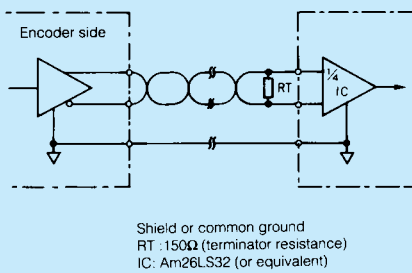

T = Average cycle
a, b, c, d = 0.25T ± 0.1T
e = 0.5T ± 0.1T
ΔT ≤ 0.1T
Z Signal is synchronized with A Signal

RH-8D /11D /14D Open Collector DO

● Output Circuit

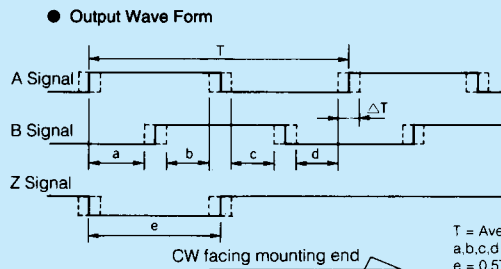
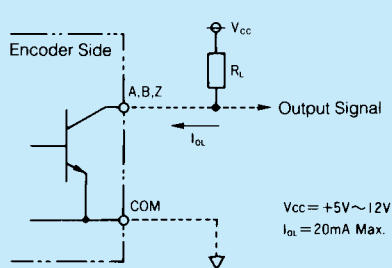

T = Average cycle
a, b, c, d = 0.25T ± 0.1T
e = 0.5T ± 0.1T
ΔT ≤ 0.1T
Z Signal is synchronized with A Signal

Encoder Wiring

Table 7

RH-5A/8D/11D/14D ¹⁾	Line Driver AL/BL	Open Collector AO	Open Collector DO
Brown	A Signal	A Signal Output	A Signal Output
Blue	\bar{A} Signal	NA	A Signal Common
Red	B Signal	B Signal Output	B Signal Output
Green	\bar{B} Signal	NA	A Signal Common
Yellow	Z Signal	Z Signal Output	Z Signal Output
Orange	\bar{Z} Signal	NA	A Signal Common
White	Power Supply	Power Supply	Power Supply
Black	Common	Common	Common
Shield	Floating	Floating	Floating

¹⁾ Please Note: If the option tach-generator is used in combination with an encoder the wiring of the encoder may vary from the above table.

Encoder Resolutions

Table 8

Actuator	Resolution						
	100	200	300	360	500	720	1000
RH-5A	—	○	—	●	○	—	—
RH-8D/11D/14D	—	○	—	○	○	—	●

● = Standard ○ = Available (special option) — = not available

Since the encoder is connected to the motor side, the resolution is calculated at the actuator output shaft as shown below. For example, when the reduction ratio is 1:100, and the resolution of an encoder is 1000, the resolution at the output shaft becomes $1000 \times 100 = 100000$.

Tach and Encoder Configurations

Table 9

Actuator	Tach	AO	DO	AL	BL
RH-5A	no	●	—	●	—
RH-8D/11D/14D	no	—	●	●	●
RH-8D/11D/14D	yes	—	○	○	—

● = Standard — = not available ○ = Option

Encoder Lead Wires

Table 10

Actuator	Tach	Open Collector AO		Open Collector DO		Line Driver AL		Line Driver BL	
		Length (mm)	Diameter	Length (mm)	Diameter	Length (mm)	Diameter	Length (mm)	Diameter
RH-5A	no	300	4	—	—	600	4	—	—
RH-8D/11D/14D	no	—	—	600	4	600	4	600	4
RH-8D/11D/14D	yes	600	4	—	—	600	5	—	—

Weights

Table 11

Actuator	Gearbox and Motor	Including Tach	Including Encoder	Including Tach and Encoder
RH-5A	0.07	—	0.09	—
RH-8D	0.27	0.35	0.31	0.39
RH-11D	0.47	0.55	0.51	0.59
RH-14D	0.74	0.82	0.78	0.86

Output Shaft Tolerances

The following table provides the geometric tolerances for the output shaft.

mm

Table 12

Actuator	Concentricity \odot a	Perpendicularity \perp b	Run-out \blacktriangleright c
RH-5A	0.04	0.04	0.02
RH-8D	0.04	0.04	0.02
RH-11D	0.04	0.04	0.02
RH-14D	0.04	0.04	0.02

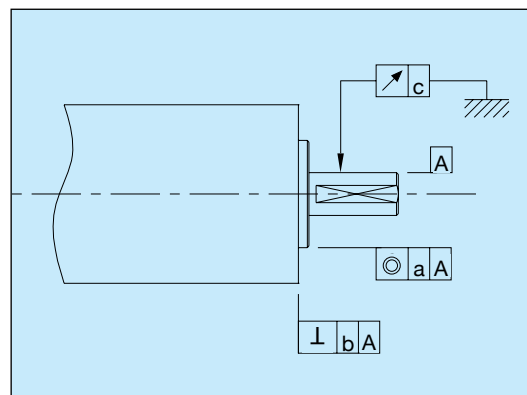

Dimensions

mm

RH-5A-XX02 Actuator Only

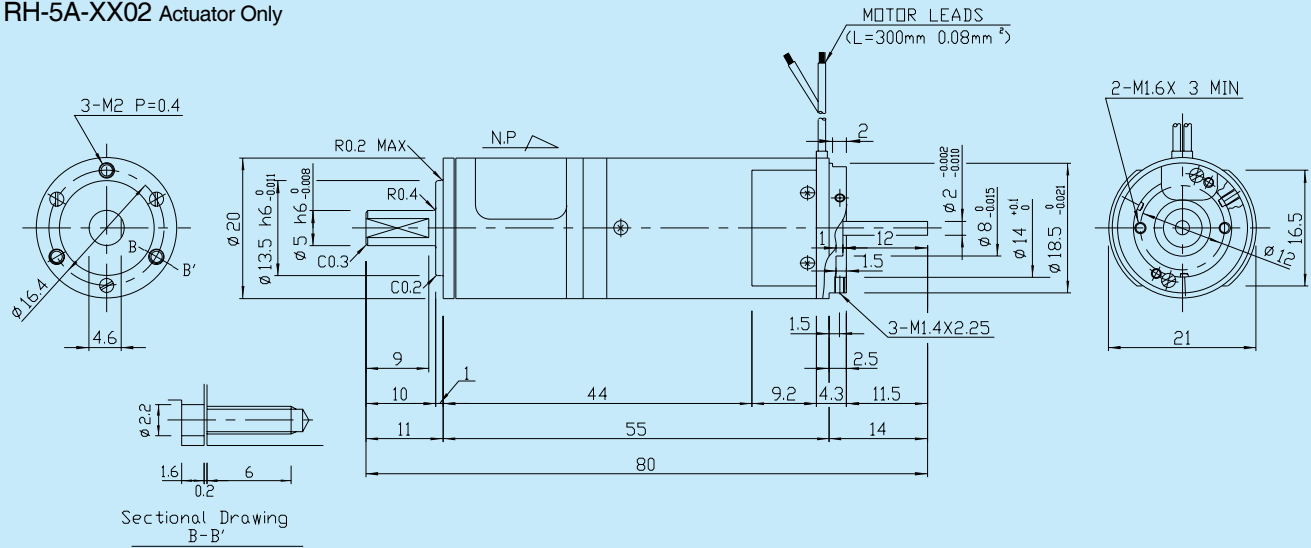

RH-5A-XX02-E036AO With 360 PPR Encoder

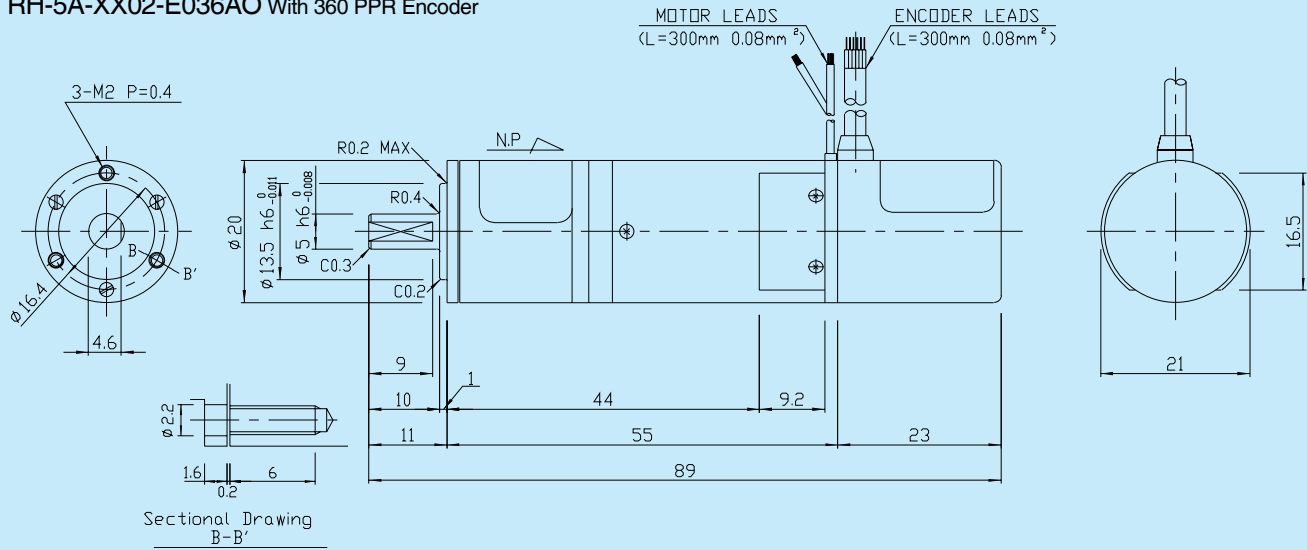

RH-5A-XX02-E050AO With 500 PPR Encoder

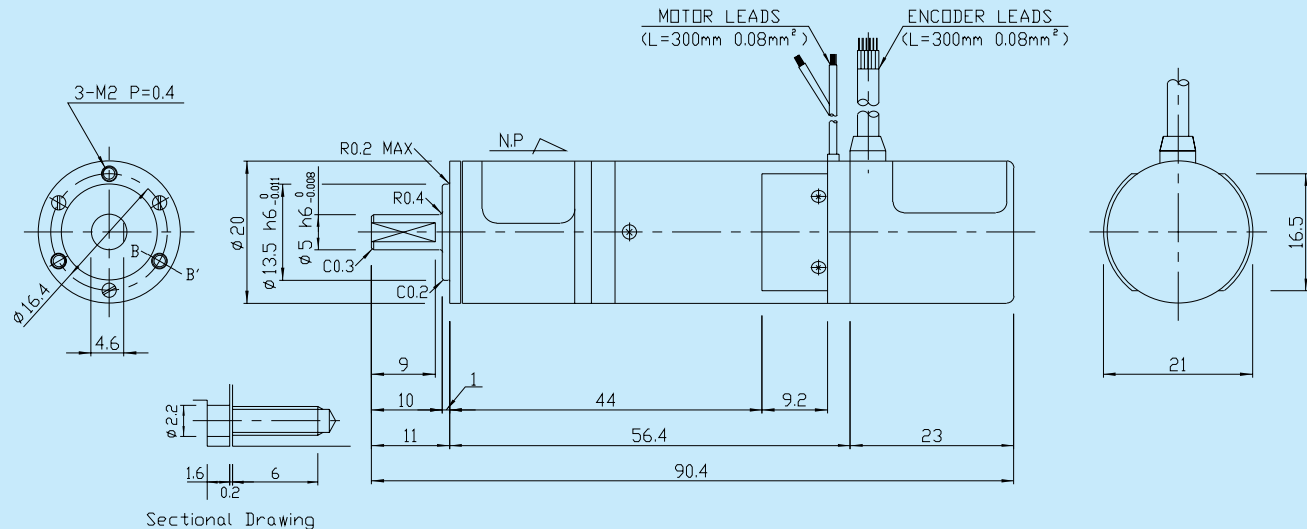

Please Note: Valid for encoder types AO, DO and AL. Please add 9 mm for the BL-type encoder.

RH-8D-XX06 Actuator Only

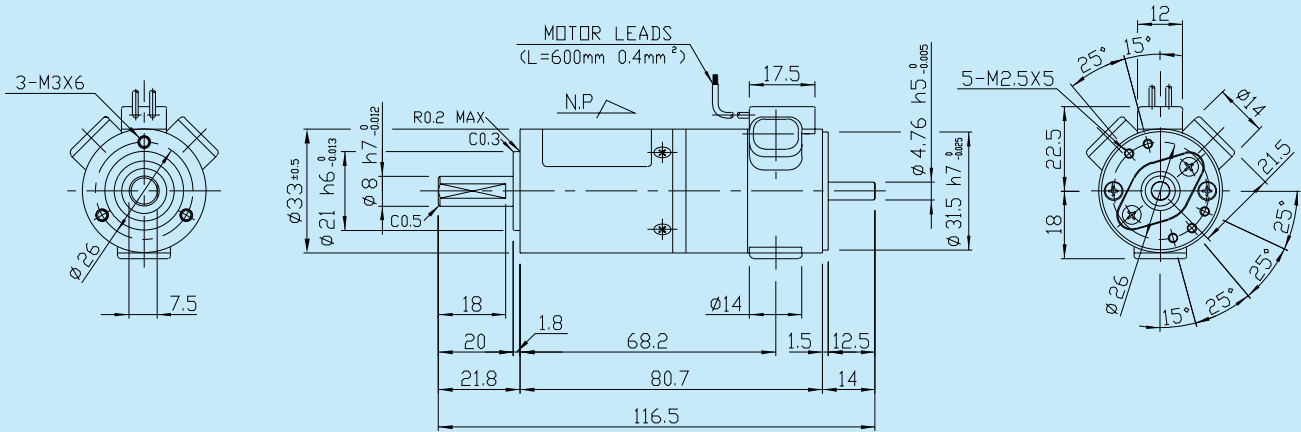

RH-8D-XX06-T With Tach-Generator

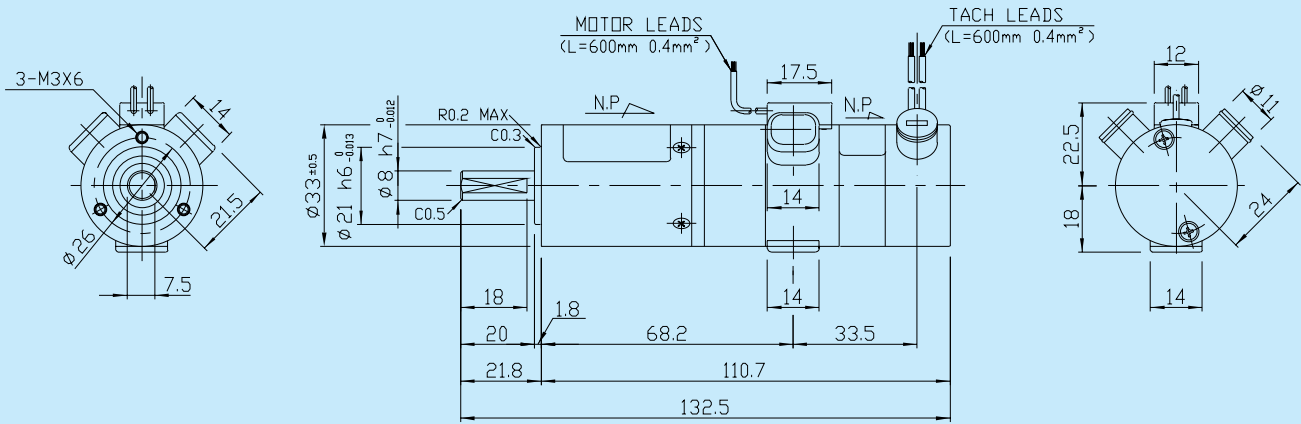

RH-8D-XX06-E With Encoder

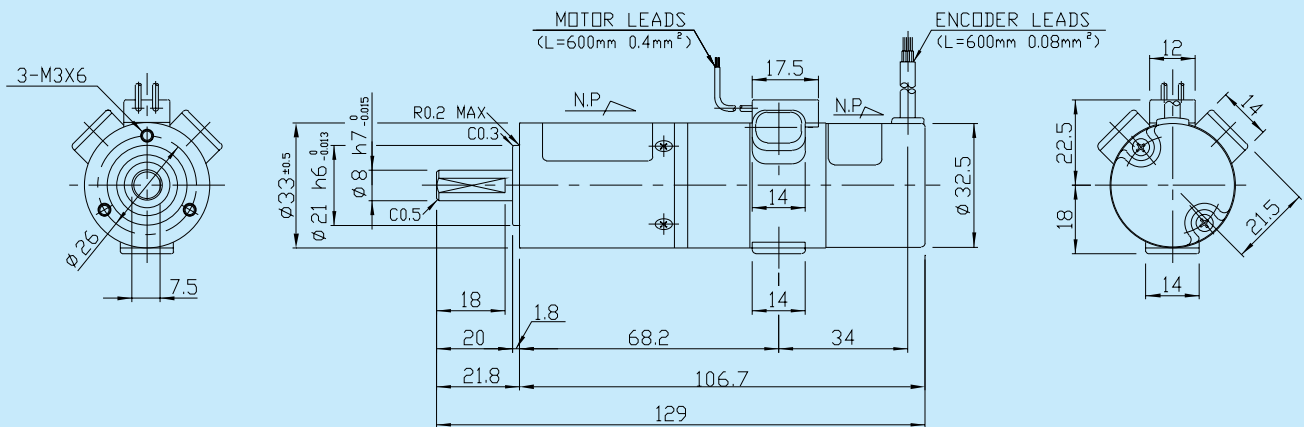

Please Note: Valid for encoder types AO, DO and AL. Please add 9 mm for the BL-type encoder.

RH-14D-XX02 Actuator Only

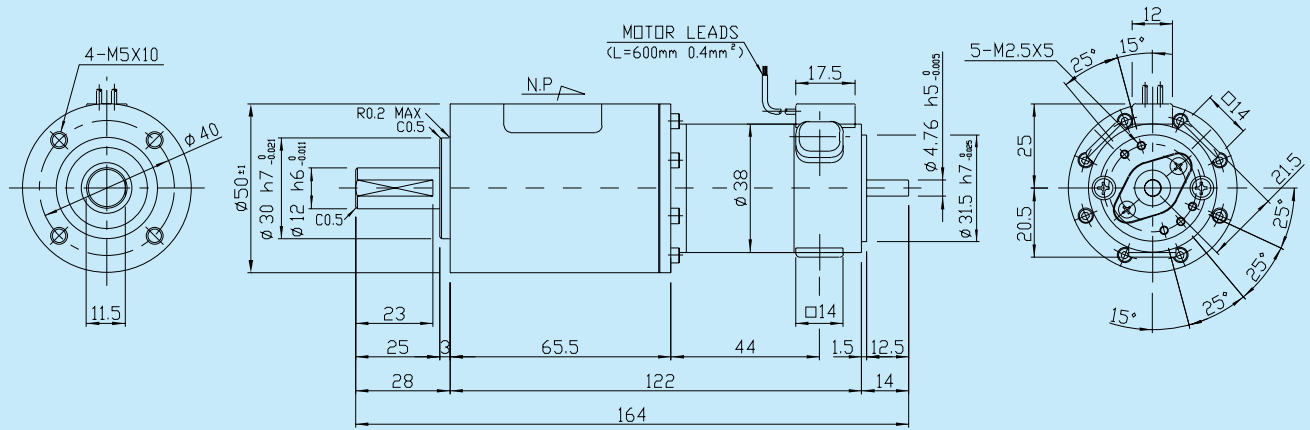

RH-14D-XX02 With Tach-generator

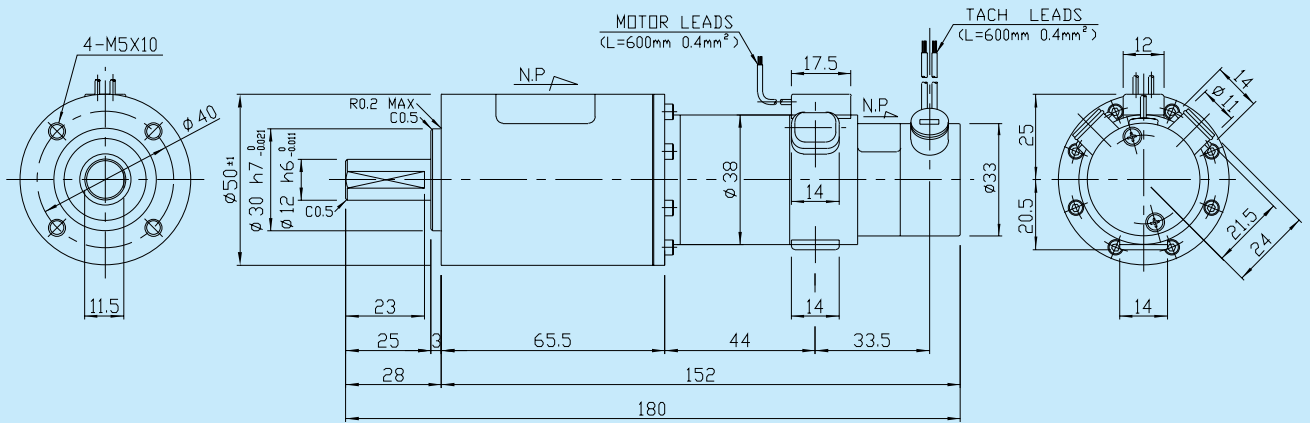

RH-14D-XX02-E With Encoder

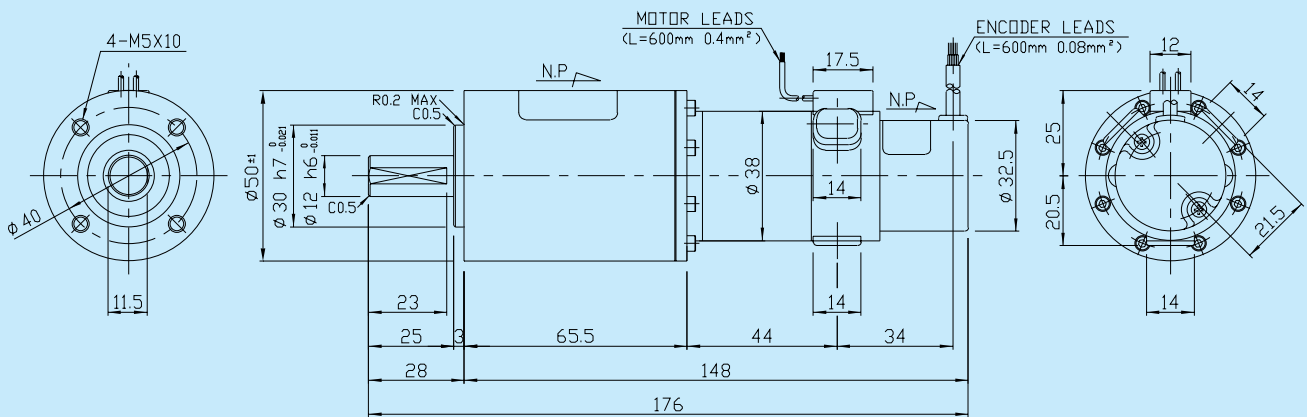

Ordering Codes

Servo Actuators

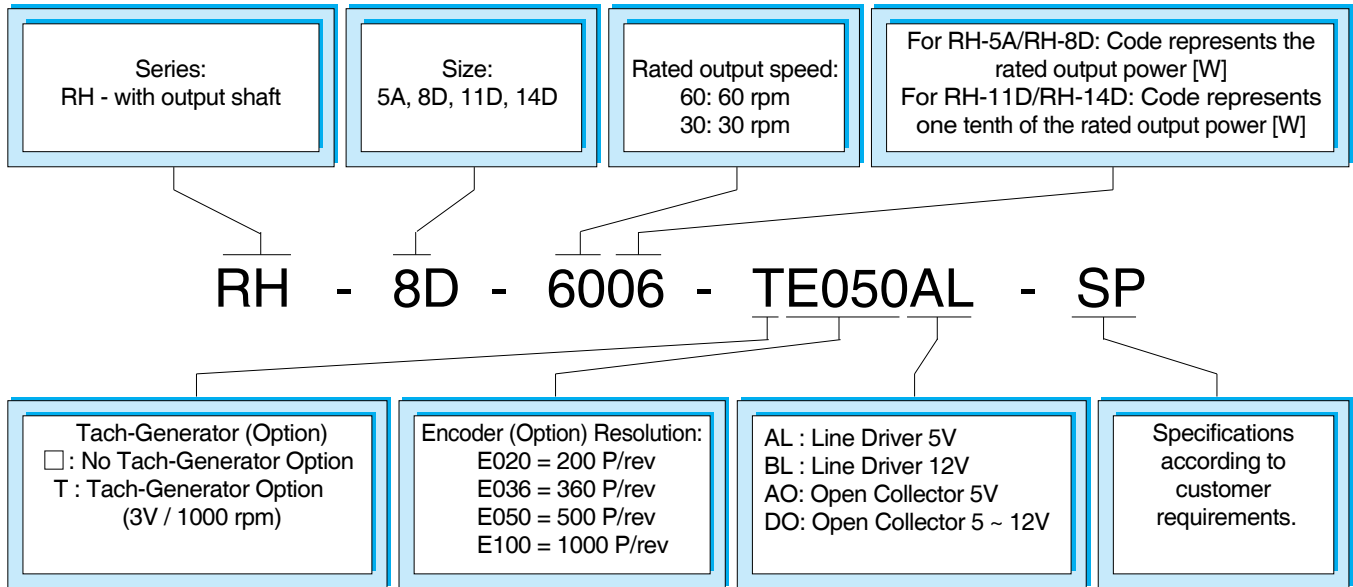

ALL PRODUCTS ARE WARRANTED TO BE FREE FROM DESIGN OR MANUFACTURING DEFECTS FOR A PERIOD OF ONE YEAR FROM THE DATE OF SHIPMENT. SUCH ITEMS WILL BE REPAIRED OR REPLACED AT THE DISCRETION OF HARMONIC DRIVE LLC.

THE SELLER MAKES NO WARRANTY, EXPRESSED OR IMPLIED, CONCERNING THE MATERIAL TO BE FURNISHED OTHER THAN IT SHALL BE OF THE QUALITY AND SPECIFICATIONS STATED. THE SELLER'S LIABILITY FOR ANY BREACH IS LIMITED TO THE PURCHASE PRICE OF THE PRODUCT.

ALL EFFORTS HAVE BEEN MADE TO ASSURE THAT THE INFORMATION IN THIS CATALOG IS COMPLETE AND ACCURATE. HOWEVER, HARMONIC DRIVE LLC IS NOT LIABLE FOR ANY ERRORS, OMMISIONS OR INACCURACIES IN THE REPORTED DATA. HARMONIC DRIVE LLC RESERVES THE RIGHT TO CHANGE THE PRODUCT SPECIFICATIONS, FOR ANY REASON, WITHOUT PRIOR NOTICE.



Harmonic Drive LLC

Boston US Headquarters

247 Lynnfield Street
Peabody, MA 01960

New York Sales Office

100 Motor Parkway
Suite 116
Hauppauge, NY 11788

California Sales Office

333 W. San Carlos Street
Suite 1070
San Jose, CA 95110

Chicago Sales Office

137 N. Oak Park Ave., Suite 410
Oak Park, IL 60301

T: 800.921.3332

T: 978.532.1800

F: 978.532.9406

www.HarmonicDrive.net

Group Companies

Harmonic Drive Systems, Inc.
6-25-3 Minami-Ohi, Shinagawa-ku
Tokyo 141-0013, Japan

Harmonic Drive AG
Hoenbergstrasse, 14, D-6555
Limburg/Lahn Germany

