

FD Gearing

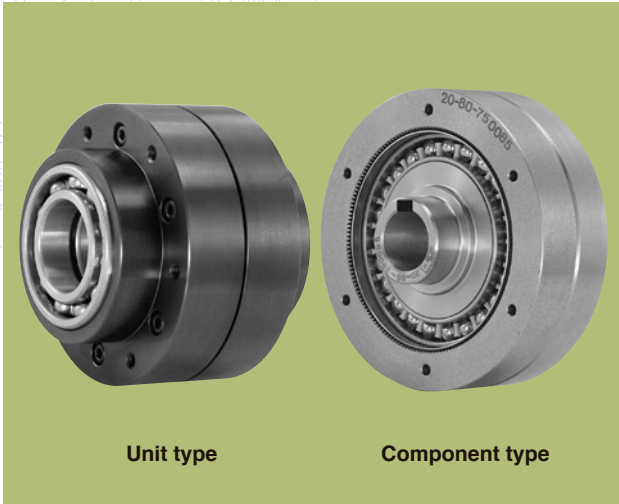

Harmonic Drive[®] gear
Precision Gearing and Motion Control

Features



Differential unit FD series

The differential unit FD series is an extremely compact differential unit that allows you to fine-tune the phase and timing during operation by applying the unique operating principle of HarmonicDrive®.

The FD series consist of four parts like the pancake-type component unit. The unit type is cased so that the gear and pulley for transmission can be directly installed in it.

Features of FD series

- ? As the differential mechanism is put together as one, it is easily installed in the equipment.
- ? It consists of only four parts and is coaxially put together.
- ? As the backlash is very small, the unit requires no assembly adjustment at all, which helps reduce the assembly cost significantly.
- ? As it has very large reduction ration between the adjusting shaft and the output, it allows highly accurate and minute position adjustment easily and requires little torque for adjusting the shaft.

Structure of the FD series

Fig. 2-1

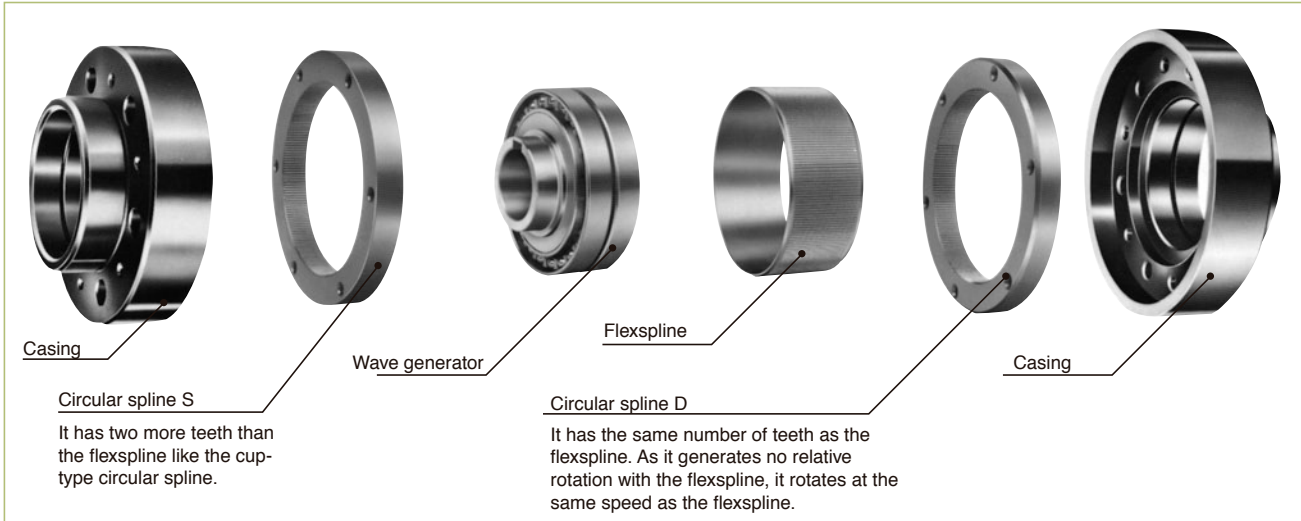
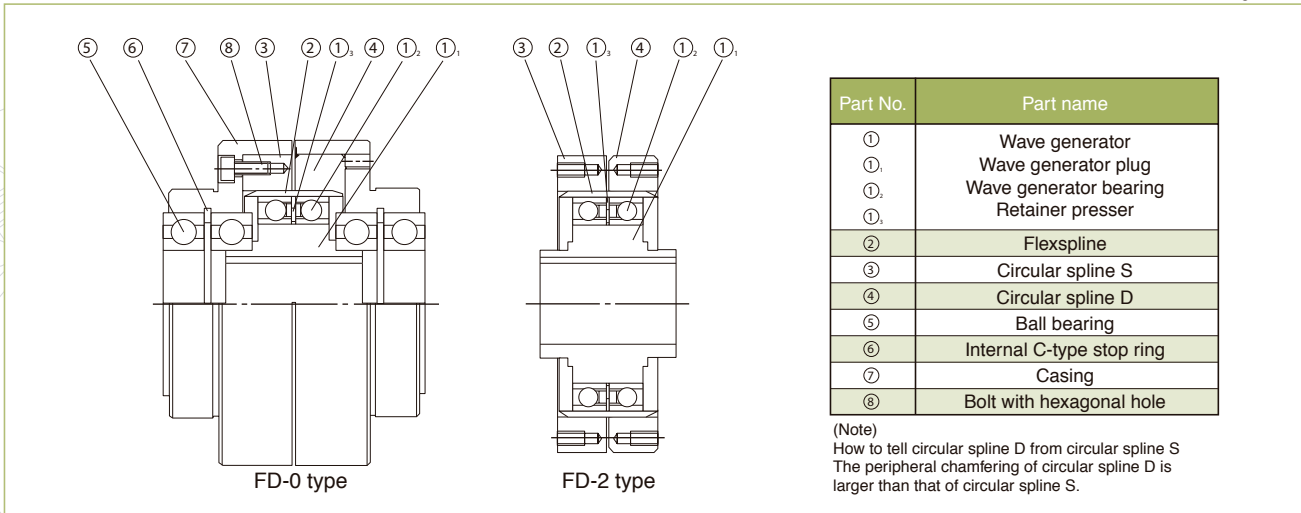

Fig. 2-2



Rotational direction and reduction ratio

The rotational direction is the same as the FB series (Page 105). This section describes how to use the unit as a differential unit. (R indicates the reduction ratio value in the ratings table.)

图3-1



图3-2



How to use

Usage example

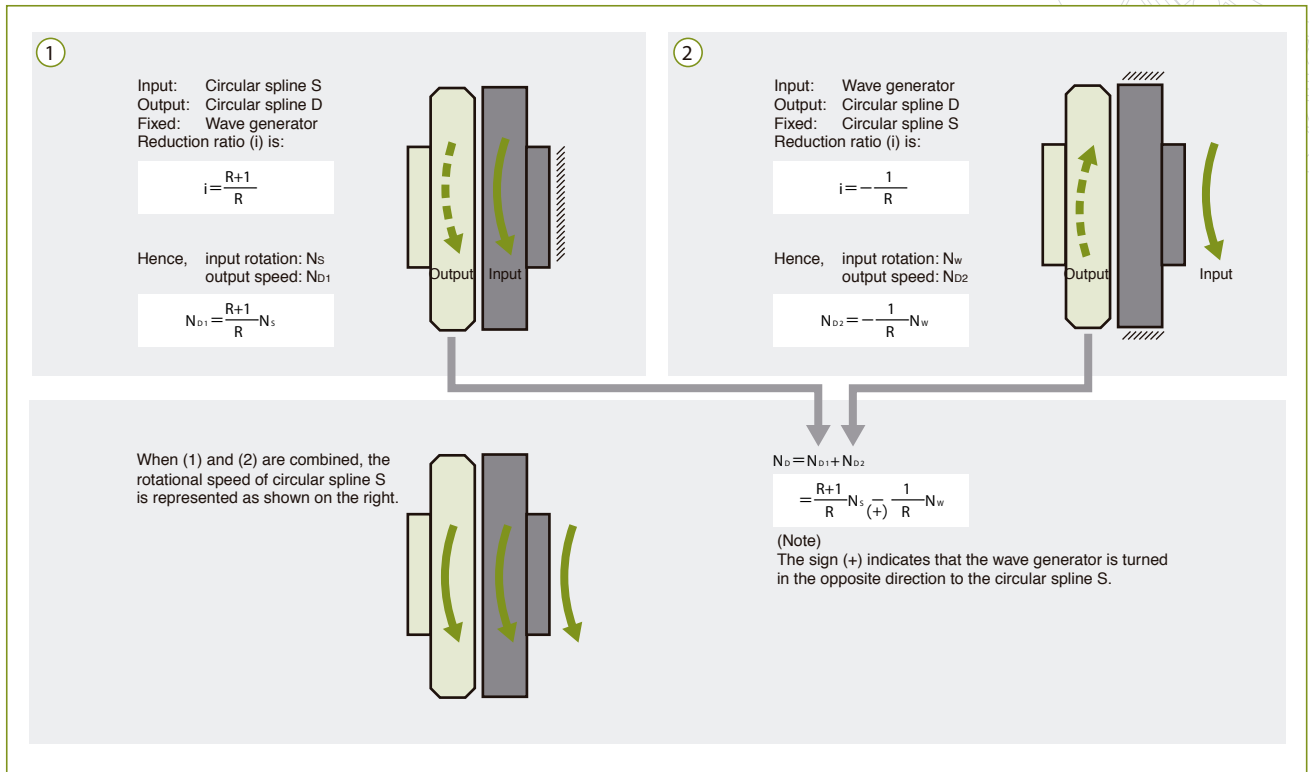
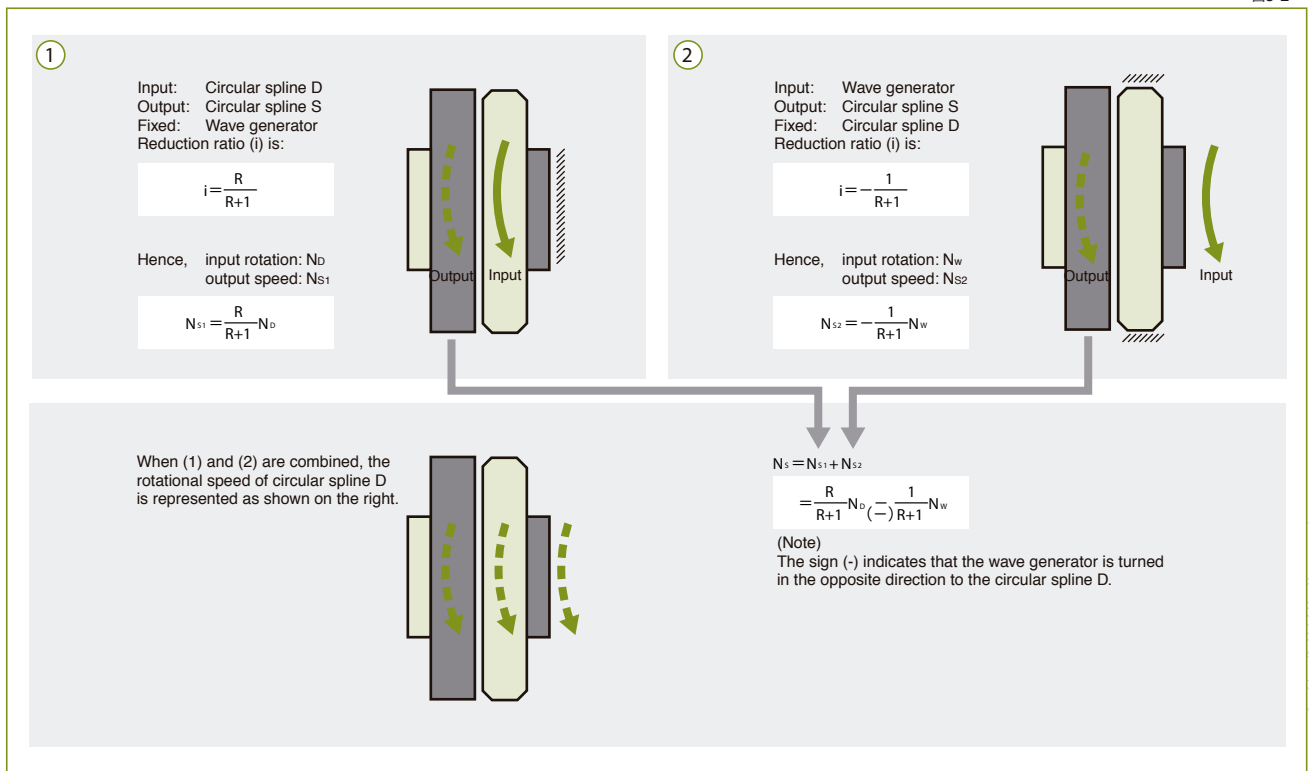
Phase adjustment

Fig. 5-1

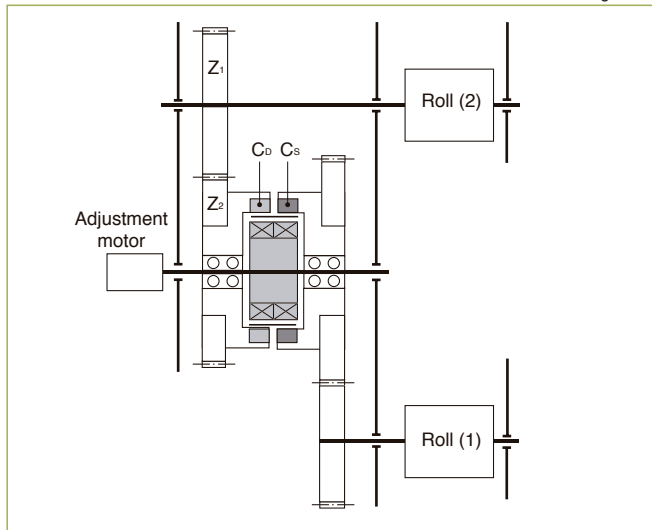

Brake a unit to adjust the phase of two rolls, normally an adjusting motor, and rotate it in the system: roll (1) → C_s → C₀ → Roll (2). When the phase of Roll (2) against Roll (1) needs to be adjusted, the adjusting motor should be rotated. Stop the motor after adjustment and return Roll (2) to the original rotation.

(Calculation formula)

When the adjusting motor is fixed, the rotational speed of Roll (2) should be N₀. Assuming that the adjusting motor rotates in N_w, rotational speed N of the roll is expressed as follows.

Formula 253-1

$$N = N_0 \pm \frac{1}{R} \left(\frac{Z_2}{Z_1} \right) N_w$$

(The sign is minus (-) when the wave generator rotates in the same direction as the circular spline. It is plus (+) when the wave generator rotates in the opposite direction.)

Fine adjustment

Fig. 5-2

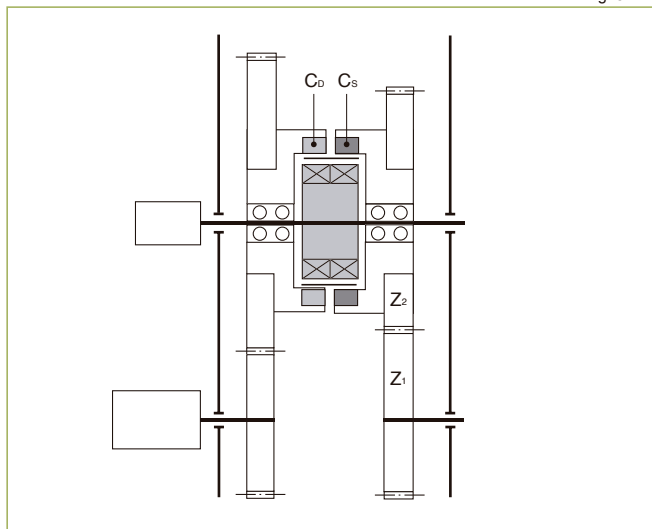

This is the method to fine-tune the speed and timing of the drive shaft by the adjusting motor without changing the rotational speed of the main motor.

(Calculation formula)

When the adjusting motor is fixed, the rotational speed of the drive shaft is expressed as follows.

Formula 253-2

$$N = N_0 \pm \frac{1}{R+1} \left(\frac{Z_2}{Z_1} \right) N_w$$

(The sign is minus (-) when the wave generator rotates in the same direction as the circular spline. It is plus (+) when the wave generator rotates in the opposite direction.)

Continuous operation adjustment

Fig. 5-3

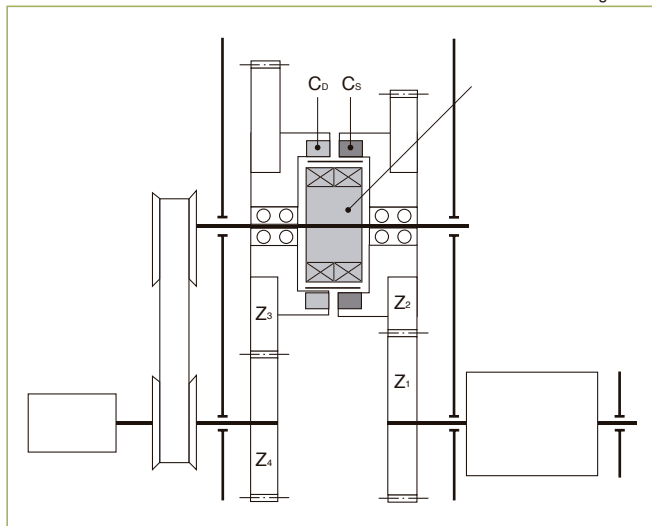

This is a unit to continuously make a slight change to the rotational speed of the roll. The rotation of the main motor has the following two routes.

- (1) Z₄ → Z₃(C₀) → Z₂(C_s) → Z₁ → Roll
- (2) Variable-speed pulley → wave generator → C_s (Z₂) → Z₁ → Roll

The speed change of the roll is given by (2).

(Calculation formula)

Assuming that the rotation of the variable-speed pulley is zero, the rotational speed of the roll rotated by the main motor is N₀. When the rotation of the wave generator, namely the variable-speed pulley, changes from N₁ to N₂, rotational speed N of the roll is expressed as follows.

Formula 253-3

Thus,

$$N = N_0 \pm \frac{1}{R+1} \left(\frac{Z_2}{Z_1} \right) (N_1 \sim N_2)$$

(The sign is minus (-) when the wave generator rotates in the same direction as the circular spline. It is plus (+) when the wave generator rotates in the opposite direction.)

Example of assembly

■ Paper-cutting machine

The right-hand figure shows an example of a general application that is used for the mechanism shown below.

Outline of operation

Rollers (1), (2) and (3) are interlocked based on the rotation of the cutter. Roller (2) feeds paper for further printing on the printed paper that is then extracted by Roller (1). Roller (2) adjusts the misaligned printing.

Roller (1) adjusts the printed paper so that it will be cut in the correct position by Roller (2). Roller (3) makes further adjustment following Roller (1).

You can change the phase between the rollers by building a Harmonic differential in Units (1), (2) and (3) without stopping the unit.

Fig. 6-1

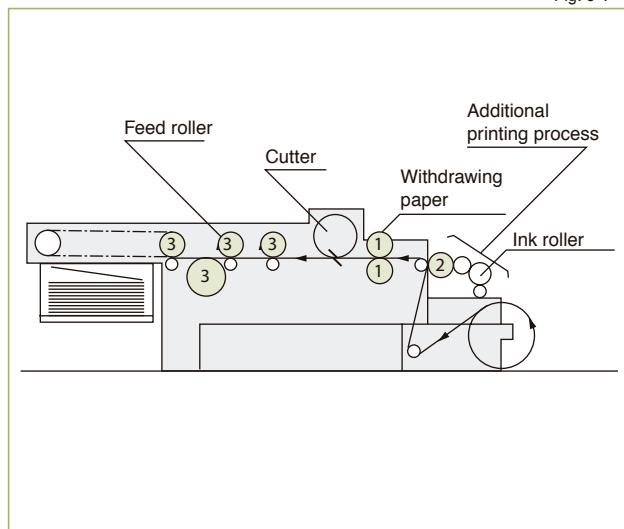

■ Printer (film material)

The following process is essential for printing on elastic material.

1. A device to adjust printing misalignment by expansion and contraction
2. A device to continue tensioning film to prevent wrinkling

Outline of operation

The film material is withdrawn by (1_a).

(1_b) tensions film between (1_a) and (1_b) to prevent wrinkling during the printing process (5). In the printing process (5), all rollers from (5₁) to (5₆) are used for 6-color printing. Adjustment is made to (5₂) based on (5₁), to (5₃) based on (5₂) and so on up to (5₄) by the Harmonic differential.

The harmonic differential is built in for all rollers from (1_a) to (5₄).

Fig. 6-2

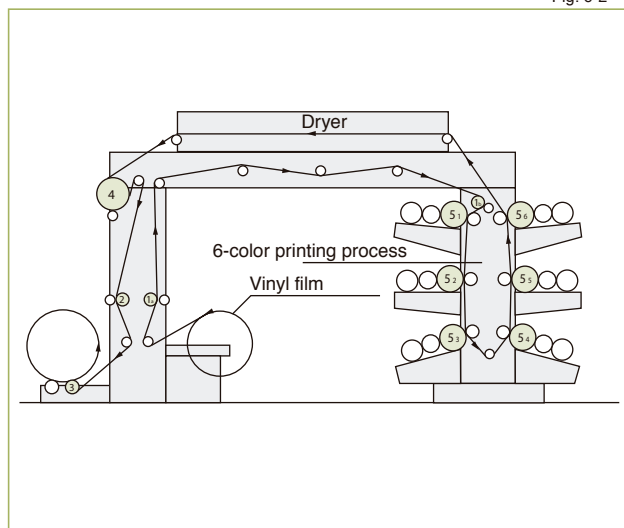

Difference between the differential gear and the Harmonic differential

Table 7-1

Differential gear	Harmonic differential
As many gears are required in the differential device, the device increases in size, causing problems in design, and is difficult to build.	As the Harmonic differential includes the differential mechanism, it can be designed to be of compact size and is easily built in.
A unit using a planet gear causes a lot of backlash and is disadvantageous in position and timing precision.	As it causes little small backlash, it is advantageous in position and timing precision.
It is not easy to fine tune compared to the Harmonic differential.	As it has a large reduction ratio, it can produce very fine tuning.
Noisy gear sound	Very quiet.

That shown in the right-hand figure is a differential gear used in a printer maker. It is an example of very smart, compact design using the Harmonic differential.

Conventional differential gear

Fig. 7-1

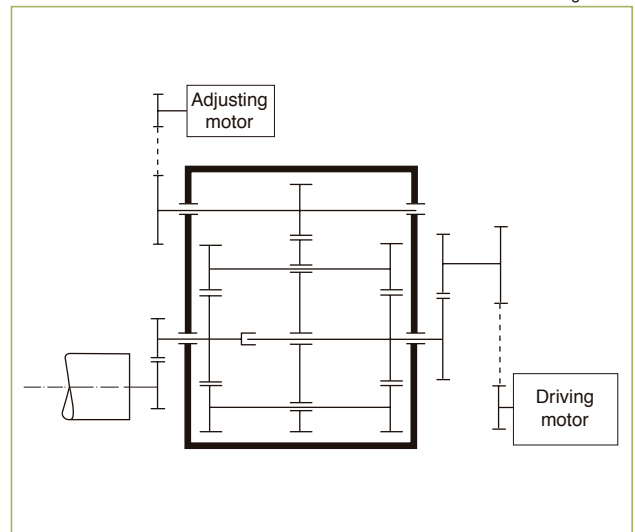

Using the Harmonic differential

Fig. 7-2

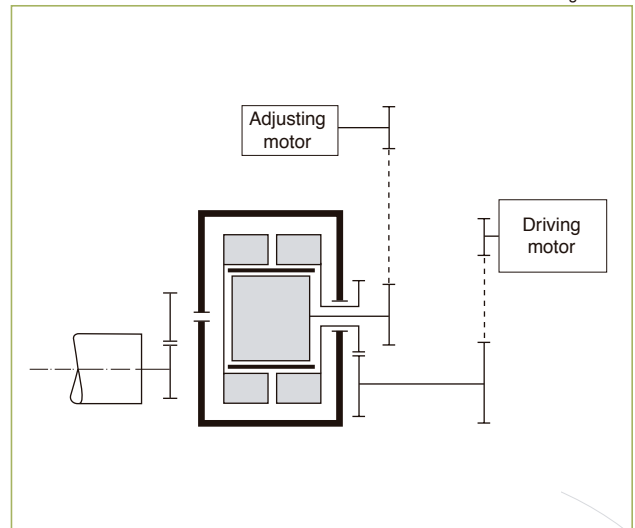

Example of design

■ Multicolor printer Phase adjuster

Fig. 8-1

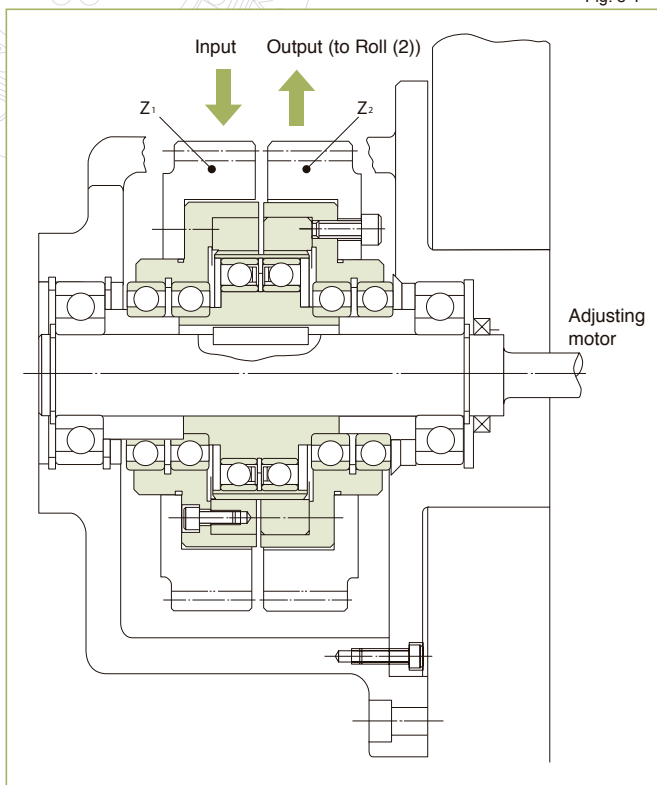

The figure is an example of a Harmonic differential unit built in as a phase adjuster for the roll of a multicolor printer. The adjusting motor is fixed during normal operation, and the rotation at Z1 is transmitted to Z2 almost at a ratio of 1:1. To adjust the phase of only Roll (2), rotate the adjusting motor to generate a small rotational difference. After adjustment, stop the motor to bring Roll (2) back to the original rotational speed.

Gear selection data

The selection data of the number of teeth, Z_1 , Z_2 , Z_3 and Z_4 , of the gear is shown when rotational speed N_1 is equal to N_2 ,

$$\text{namely } i = \frac{N_2}{N_1} = 1.$$

Where,

$$\frac{N_2}{N_1} = i = \frac{Z_1}{Z_2} \cdot \frac{Z_D}{Z_5} \cdot \frac{Z_3}{Z_4} \dots \dots \dots (i) \quad \begin{array}{l} Z_s: \text{the number of teeth of circular spline S} \\ Z_d: \text{the number of teeth of circular spline D} \end{array}$$

$$\text{Here } i_D = \frac{Z_D}{Z_5} \left(\text{or } \frac{R}{R+1} \right) \text{ makes}$$

$$i = \frac{Z_1}{Z_2} \cdot \frac{Z_3}{Z_4} \cdot i_D$$

Tabl 8-1

i_D	$\frac{Z_1 \cdot Z_3}{Z_2 \cdot Z_4}$						
$\frac{80}{81}$	$\frac{18 \cdot 18}{16 \cdot 20}$	$\frac{18 \cdot 27}{16 \cdot 30}$	$\frac{15 \cdot 27}{16 \cdot 25}$	$\frac{18 \cdot 27}{20 \cdot 24}$	$\frac{21 \cdot 27}{20 \cdot 28}$	$\frac{27 \cdot 39}{26 \cdot 40}$	
$\frac{120}{121}$	$\frac{22 \cdot 22}{20 \cdot 24}$						
$\frac{128}{129}$	$\frac{15 \cdot 43}{16 \cdot 40}$	$\frac{33 \cdot 43}{32 \cdot 40}$	$\frac{43 \cdot 63}{42 \cdot 64}$				
$\frac{160}{161}$	$\frac{14 \cdot 23}{16 \cdot 20}$	$\frac{21 \cdot 23}{20 \cdot 24}$	$\frac{23 \cdot 77}{22 \cdot 80}$	$\frac{23 \cdot 35}{25 \cdot 32}$			

(Note)

- The number of teeth given above is applicable when Z_D and Z_5 are arranged as shown in the figure.
- The difference in the number of teeth is adjusted to $Z_1-Z_2? 3$ and $Z_3-Z_4? 3$.
- It is useful to break down i_D to prime numbers to use a different number of teeth.
It is not possible to break down i_D to prime numbers for $R=79, 96, 100, 131, 208$ and 258 .

Fig. 8-2

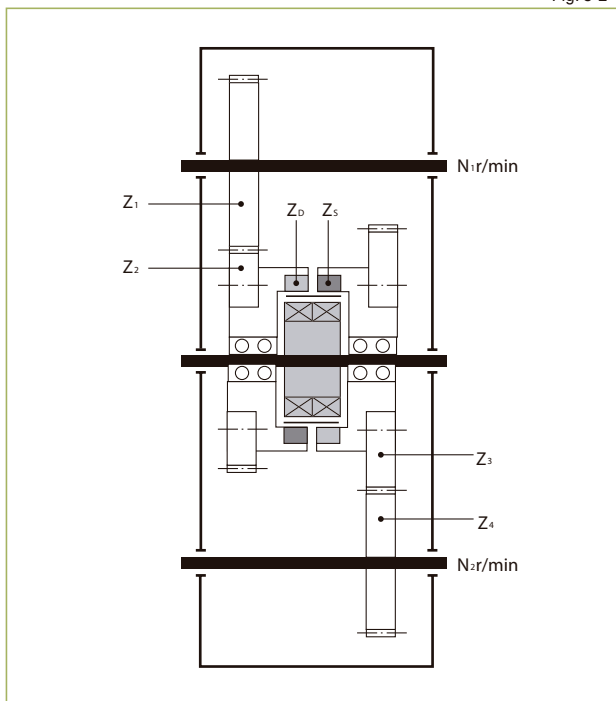

Example of calculation

This is to calculate the torque required for the number of teeth of the gear, rotational speed, adjustment quantity and adjustment based on the example shown in the right-hand figure.

[Usage condition]

In Figure 257-1

Speed around the roller	$V=60\text{m/min}$
Length around the roller	$L_w=500\text{mm}$
Roller torque	$T_w=7\text{kg}\cdot\text{m}$
Rotational speed of the drive shaft	$N_1=500\text{r/min}$
Rotational speed of the roller	$N_4 = \frac{V}{L_w} = \frac{60}{0.5} = 120\text{r/min}$

■ The number of teeth of each gear (selection of Z_1 , Z_2 , Z_3 and Z_4)

The total reduction ratio is as follows.

$$i = \frac{N_4}{N_1} = \frac{Z_2}{Z_1} \cdot \frac{C_s}{C_D} \cdot \frac{Z_4}{Z_3}$$

$$\frac{Z_2 \cdot Z_4}{Z_1 \cdot Z_3} = \frac{N_4 \cdot C_D}{N_1 \cdot C_s}$$

$$\frac{N_4}{N_1} = \frac{120}{500} = \frac{2^3 \times 3 \times 5}{2^2 \times 5^3}$$

$$\frac{C_D}{C_s} = \frac{80}{81} = \frac{2^4 \times 5}{3^4}$$

$$\frac{Z_2}{Z_1} \times \frac{Z_4}{Z_3} = \frac{2^3 \times 3 \times 5}{2^2 \times 5^3} \times \frac{2^4 \times 5}{3^4} = \frac{2^5}{3^3 \times 5} = \frac{2^3}{3 \times 5} \times \frac{2^2}{3^2} = \frac{8}{15} \times \frac{4}{9} = \frac{16}{30} \times \frac{16}{36}$$

$$Z_1=30, Z_2=16, Z_3=36, Z_4=16$$

■ Calculation of rotational speed

The rotational speed of each gear is shown below.

$$Z_4 : N_1 = 500\text{r/min}$$

$$Z_3 : N_3 = \frac{Z_4}{Z_3} \cdot N_1 = \frac{16}{36} \times 500 = 222.2\text{r/min}$$

$$Z_2 : N_2 = \frac{C_s}{C_D} \cdot N_3 = \frac{81}{80} \times 222.2 = 225\text{r/min}$$

$$Z_1 : N_4 = 120\text{r/min}$$

■ Adjustment quantity

The misalignment (adjustment quantity), $\Delta\theta$, at the roller is expressed as follows when the adjusting wave generator rotates once (360°).

$$\Delta\theta = \frac{Z_2}{Z_1} \cdot \frac{1}{R} \cdot \theta = \frac{16}{30} \times \frac{1}{80} \times 360^\circ = 2.4^\circ$$

Therefore, the adjustment quantity is expressed as follows in the circle.

$$\Delta\theta = \frac{2.4^\circ}{360^\circ} \times 500\text{mm} = 3.3\text{mm}$$

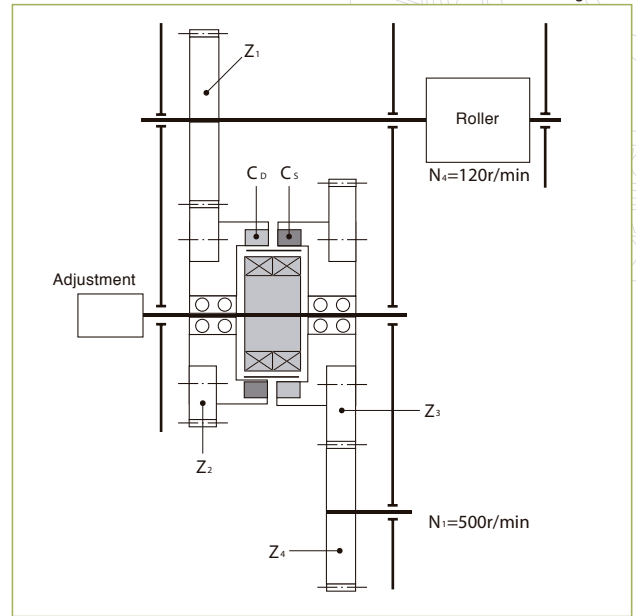

■ Adjustment torque required

The torque required for adjustment is expressed as follows.

$$T = T_w \cdot \frac{Z_2}{Z_1} \cdot \frac{1}{R} \cdot \frac{1}{\eta} = 7\text{kg}\cdot\text{m} \times \frac{16}{30} \times \frac{1}{80} \times \frac{1}{0.6} = 0.07\text{kg}\cdot\text{m}$$

(η :: efficiency)

Technical data

Rating table

The rated torque at each rotational speed is shown below.

Table 10-1

Rotational speed r/min		3500		2850		1750		1450		1150		960		870		750		600		500	
Model	Reduc. ratio	Nm	kgfm	Nm	kgfm	Nm	kgfm	Nm	kgfm	Nm	kgfm	Nm	kgfm	Nm	kgfm	Nm	kgfm	Nm	kgfm	Nm	kgfm
20	80	29	3.0	30	3.1	30	3.1	30	3.1	30	3.1	30	3.1	30	3.1	30	3.1	30	3.1	30	3.1
	100	30	3.1	31	3.2	36	3.7	36	3.7	36	3.7	36	3.7	36	3.7	36	3.7	36	3.7	36	3.7
	128	31	3.2	34	3.5	42	4.3	43	4.4	43	4.4	43	4.4	43	4.4	43	4.4	43	4.4	43	4.4
	160	32	3.3	35	3.6	42	4.3	45	4.6	48	4.9	49	5.0	49	5.0	49	5.0	49	5.0	49	5.0
25	80	46	4.7	50	5.1	57	5.8	57	5.8	57	5.8	57	5.8	57	5.8	57	5.8	57	5.8	57	5.8
	100	49	5.0	53	5.4	67	6.8	67	6.8	79	8.1	79	8.1	79	8.1	79	8.1	79	8.1	79	8.1
	120	52	5.3	55	5.6	70	7.1	70	7.1	80	8.2	82	8.4	89	9.1	91	9.3	96	9.8	96	9.8
	160	54	5.5	57	5.8	71	7.2	73	7.4	80	8.2	83	8.5	89	9.1	92	9.4	98	10	108	11
	200	55	5.6	59	6.0	71	7.2	74	7.5	80	8.2	84	8.6	89	9.1	92	9.4	98	10	108	11
32	78	98	10	108	11	108	11	108	11	108	11	108	11	108	11	108	11	108	11	108	11
	100	108	11	118	12	137	14	147	15	157	16	157	16	157	16	157	16	157	16	157	16
	131	108	11	118	12	137	14	157	16	167	17	176	18	176	18	196	20	206	21	206	21
	157	108	11	118	12	137	14	157	16	167	17	176	18	176	18	196	20	206	21	216	22
	200	108	11	118	12	137	14	157	16	167	17	176	18	176	18	196	20	206	21	216	22
40	80	196	20	196	20	196	20	196	20	196	20	196	20	196	20	196	20	196	20	196	20
	100	235	24	245	25	265	27	265	27	265	27	265	27	265	27	265	27	265	27	265	27
	128	235	24	245	25	294	30	314	32	343	35	363	37	372	38	372	38	372	38	372	38
	160	235	24	245	25	294	30	314	32	343	35	363	37	372	38	392	40	421	43	451	46
	200	235	24	245	25	294	30	314	32	343	35	363	37	372	38	392	40	421	43	451	46
50	80	353	36	353	36	353	36	353	36	353	36	353	36	353	36	353	36	353	36	353	36
	100	441	45	470	48	549	56	559	57	559	57	559	57	559	57	559	57	559	57	559	57
	120	441	45	470	48	549	56	588	60	637	65	666	68	666	68	666	68	666	68	666	68
	160	441	45	470	48	549	56	588	60	637	65	676	69	696	71	745	76	794	81	843	86
	200	441	45	470	48	549	56	588	60	637	65	676	69	696	71	745	76	794	81	843	86
65	78	—	—	—	—	764	78	764	78	764	78	764	78	764	78	764	78	764	78	764	78
	104	—	—	—	—	1030	105	1100	112	1180	120	1190	121	1190	121	1190	121	1190	121	1190	121
	132	—	—	—	—	1030	105	1100	112	1180	120	1250	128	1290	132	1380	141	1460	149	1570	160
	158	—	—	—	—	1030	105	1100	112	1180	120	1250	128	1290	132	1380	141	1460	149	1570	160
	208	—	—	—	—	1030	105	1100	112	1180	120	1250	128	1290	132	1380	141	1460	149	1570	160
80	80	—	—	—	—	1370	140	1370	140	1370	140	1370	140	1370	140	1370	140	1370	140	1370	140
	96	—	—	—	—	1800	184	1800	184	1800	184	1800	184	1800	184	1800	184	1800	184	1800	184
	128	—	—	—	—	2040	208	2180	222	2340	239	2490	254	2570	262	2710	277	2710	277	2710	277
	160	—	—	—	—	2040	208	2180	222	2340	239	2490	254	2570	262	2740	280	2950	301	3130	319
	194	—	—	—	—	2040	208	2180	222	2340	239	2490	254	2570	262	2740	280	2950	301	3130	319
	258	—	—	—	—	2040	208	2180	222	2340	239	2490	254	2570	262	2740	280	2950	301	3130	319
100	80	—	—	—	—	2470	252	2470	252	2470	252	2470	252	2470	252	2470	252	2470	252	2470	252
	100	—	—	—	—	3720	380	3720	380	3720	380	3720	380	3720	380	3720	380	3720	380	3720	380
	120	—	—	—	—	3720	382	3980	406	4280	437	4560	465	4710	481	4740	484	4740	484	4740	484
	160	—	—	—	—	3720	382	3980	406	4280	437	4560	465	4710	481	5010	511	5390	550	5720	584
	200	—	—	—	—	3720	382	3980	406	4280	437	4560	465	4710	481	5010	511	5390	550	5720	584
	242	—	—	—	—	3720	382	3980	406	4280	437	4560	465	4710	481	5010	511	5390	550	5720	584

(Note)

- Rotational speed: This indicates the rotational speed of the wave generator if used as a reducer.
This indicates the relative rotational speed of the wave generator and the circular spline if used as a differential unit.
- The torque against a rotational speed of 2500 r/min or less is equal to the torque for 500 r/min.
- The permissible momentary torque allows up to 200% of the torque at a rotational speed of 450 r/min.

Outline drawing of unit type (FD-0)

Fig. 11-1

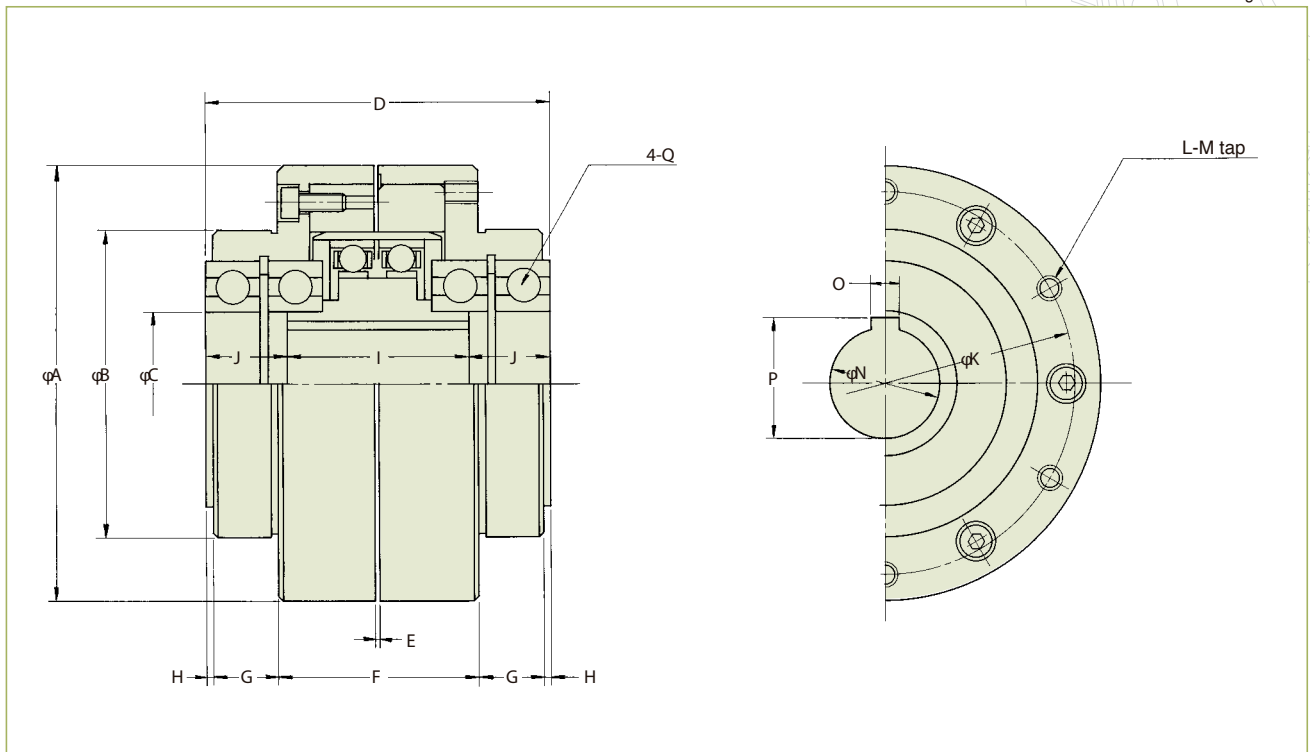

Measurement table of unit type (FD-0)

Table 11-1
Unit: mm

Symbol	Model	20	25	32	40	50	65	80	100
ϕA		85	95	120	145	185	235	290	360
ϕB_{H7}		52	65	85	100	125	140	180	210
ϕC		20	30	40	50	60	70	90	110
D		73	81	95	113	132	147	178	212
E		1	1	1	1	1	1	1	1
F		44	45	55	65	80	117	129	155
G		12.5	16	18	20	22	12	21.5	25.5
H		2	2	2	4	4	3	3	3
I		38	40	50	68	78	87	106	130
J		17.5	20.5	22.5	22.5	27	30	36	41
ϕK		70	80	105	125	155	195	240	290
L		6	6	6	6	6	6	8	8
M		M4x 7	M5x 8	M6x 10	M8x 11	M10x 13.5	M12x 23	M12x 23	M14x2 7
ϕN_{H7}		12	20	30	35	40	50	65	80
O_{J99}		4	6	8	10	12	14	18	22
P		13.8	22.8	33.3	38.3	43.3	53.8	69.4	85.4
Q		#6004	#6006	#6008	#6010	#6012	#6014	#6018	#6022
Mass (kg)		2.0	2.6	5.0	8.3	17	34	59	118

Outline drawing of component type (FD-2)

Fig. 12-1

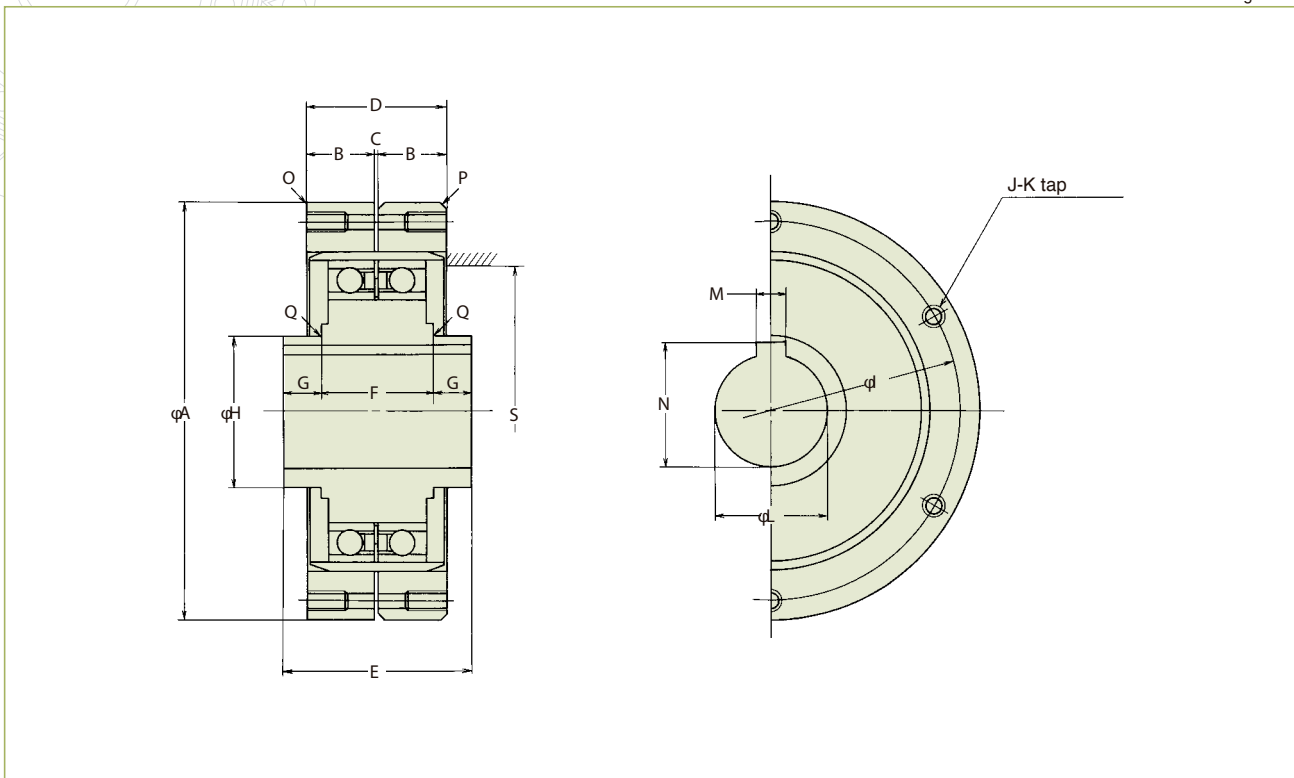

Measurement table of component type (FD-2)

Table 12-1
Unit: mm

Symbol	Model	20	25	32	40	50	65	80	100
ϕA_{g7}		70	85	110	135	170	215	265	330
B		12	14	18	21	26	35	41	50
C		1	1	1	1	1	1	1	1
D		25	29	37	43	53	71	83	101
E		38	40	50	68	78	87	106	130
F		21.5	25	30	44	54	59	74	92
G		8.25	7.5	10	12	12	14	16	19
ϕH_{j6}		20	30	40	50	60	70	90	110
ϕI		60	75	100	120	150	195	240	290
J		6	6	6	6	6	6	8	8
K		M3x 6	M4x 8	M5x 10	M6x 12	M8x 16	M10x 20	M10x 20	M12x 24
ϕL_{H7}		12	20	30	35	40	50	65	80
M_{js9}		4	6	8	10	12	14	18	22
N		13.8	22.8	33.3	38.3	43.3	53.8	69	85.4
O_c		0.2	0.2	0.2	0.4	0.4	0.4	0.4	0.4
P_c		1	1.5	1.5	1.5	1.5	1.5	2	2
Q_R		0.5	1	1	1	2	1	1.5	2
S		42	53	69	84	105	138	169	211
Mass (kg)		0.6	1.0	2.0	3.6	7.2	14	26	48

Efficiency characteristics

The efficiency of the differential unit varies depending on the power transmission route.

- The efficiency when the power enters from circular spline S (or D) to transmit the rotation to circular spline D (or S)

For oil lubrication: About 90%
For grease lubrication: About 80%

- The efficiency for obtaining the input torque required by the wave generator for phase adjustment and to use it as a reducer is shown in Graph 13-1

Efficiency

Graph 13-1

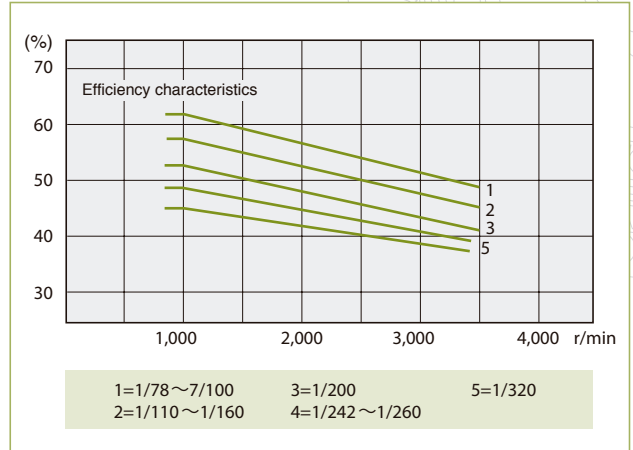

Table 261-1

Load torque	Rated torque in rating table
Lubrication condition	Oil lubrication (approx. 40%)

(Note) The efficiency decreases by about 10% for grease lubrication.

Inertia moment

The value of DG^2 of each part is shown in Table 13-1.

Table 13-2
Unit: ($\times 10^4 \text{kgm}^2$)

Model	20	25	32	40	50	65	80	100
I Wave generator (except the outer race of the wave generator)	1.44	3.63	12.9	37.0	112	366	1020	3050
II Circular spline S, D Outer ring of the wave generator	13.7	33.8	125	326	1020	3440	9270	27000
III I + II	15.2	37.5	138	363	1140	3810	10300	30100
IV Support bearing (4)	2.91	8.98	23.4	451	104	205	646	1590
V Casing () right and left casing total	52.6	69.0	204	484	1660	6220	15700	43200

Max. permissible rotational speed

The maximum permissible rotational speed means:

- The rotational speed of the wave generator when used as a reducer
- The relative rotational speed of the wave generator and the circular spline when used as a differential unit

- For oil lubrication

Table 13-3
Unit: r/min

Model	20	25	32	40	50	65	80	100
Max. permiss. rotational speed	6000	5000	4500	4000	3500	3000	2500	2000

- For grease lubrication

Table 13-4
Unit: r/min

Model	20	25	32	40	50	65	80	100
Max. permiss. rotational speed	3600	3600	3600	3300	3000	2200	2000	1700

Hysteresis loss and spring constant

See Page 20 for a definition of hysteresis loss and the spring constant. Hysteresis loss and the spring constant of the differential type is the value when either the wave generator or the circular spline is fixed and a torque is applied to another circular spline.

Table 14-1

Model	Hysteresis loss (arc min)		Spring constant (kgm/min)	
	± load (kgm)	Standard product (max.)	Load (kgm)	Spring constant
20	0.12	40	3.69	0.9
25	0.23	37	7.20	2.1
32	0.46	35	15.78	4.4
40	0.92	33	29.50	7.8
50	1.73	29	57.60	16
65	3.9	27	126.7	27
80	7.4	26	236.2	52
100	14.4	24	460.8	100

(Note) Contact us for R-specification products.

Design guide

Precautions on handling

1. The casing and the roller bearing in using a component type as a differential unit should be pursuant to the unit type (D-type).

Lubrication

There are two types of lubrication; oil lubrication and grease lubrication. Although oil lubrication is common, grease lubrication is applicable to intermittent operation.

Oil lubrication

1. Type of lubricant _____

It is same with lubrication of Cup type HarmonicDrive® (Page 18).

2. Oil quantity _____

The oil level shall be the position shown in Table 122-1.

Oil position

Table 263-1
Unit: mm

Model	20	25	32	40	50	65	80	100
A	12	15	31	38	44	62	75	94

Fig. 15-1

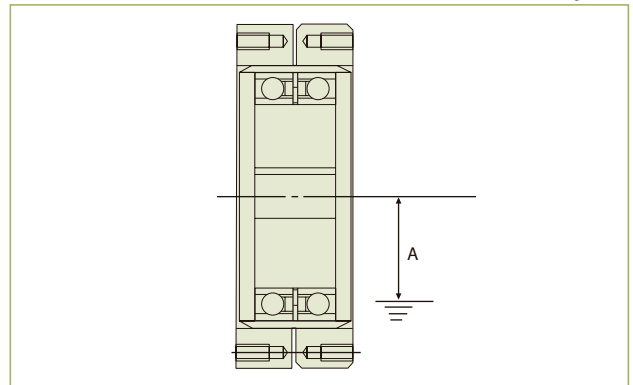

Grease lubrication

Different from oil lubrication, as a cooling effect is not expected from grease lubrication, it is only available for short operation.

- Operating condition: ED% \leq 10% or less, continuous operation for 10 minutes or less, the maximum permissible input rotational speed in Table 106-1 or less
- Recommended grease:..... Harmonic grease SK-1A for model numbers 20-100
Harmonic grease SK-2 for model number 14

Note) If you use the product over ED% or the maximum permissible rotational speed, the grease will deteriorate, will not work as a lubricating mechanism and will result in damaging the reducer earlier. Extreme care should be taken.



Harmonic Drive LLC

Boston US Headquarters
42 Dunham Ridge
Beverly, MA 01915

New York Sales Office
100 Motor Parkway
Suite 116
Hauppauge, NY 11788

California Sales Office
333 W. San Carlos Street
Suite 1070
San Jose, CA 95110

Chicago Sales Office
137 N. Oak Park Ave., Suite 410
Oak Park, IL 60301

T: 800.921.3332
T: 978.532.1800
F: 978.532.9406

www.HarmonicDrive.net

Group Companies

Harmonic Drive Systems, Inc.
6-25-3 Minami-Ohi, Shinagawa-ku
Tokyo 141-0013, Japan

Harmonic Drive AG
Hoenbergstrasse, 14, D-6555
Limburg/Lahn Germany



Harmonic Drive is a registered trademark of Harmonic Drive LLC.