

# HarmonicDrive®

## *MECHATRONICS*

### AC Servo Actuator

# FPA Series

Reduced overall  
length

High  
performance

Energy-  
saving

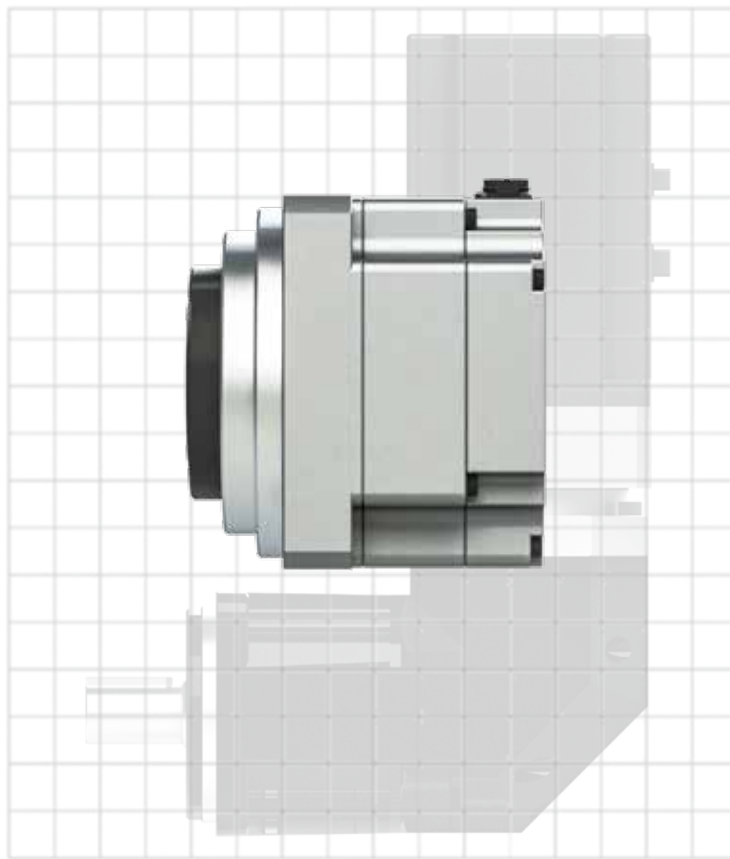

### Solving the Challenges of Orthogonal Shaft Planetary Gears and Offering Further Benefits

The AC Servo Actuator FPA Series combines the precision planetary gear speed reducer HarmonicPlanetary® with a dedicated AC servo motor.

With its flat, thin profile, the FPA Series reduces overall length compared with combinations of orthogonal shaft type speed reducers and servo motors in the same torque range.

The absence of an orthogonal section simultaneously achieves high efficiency and precision. Expected performance improvements include further miniaturization of semiconductor/FPD manufacturing equipment, robots, machine tools, and various FA equipment, as well as enhanced precision and efficiency for all equipment using orthogonal planetary speed reducers. In addition to the dedicated HA-900 series driver, it is also compatible with Mitsubishi Electric's MELSERVO J5 series and Panasonic's MINAS A6 series.

## Features

### ◆ Flat and Low Profile

The precision planetary gear speed reducer HarmonicPlanetary<sup>®</sup> and flat AC servo motor are coaxially integrated, achieving a flat profile. This design allows for a shorter overall length and further miniaturization of equipment.

### ◆ Low Loss

The absence of an orthogonal gear section minimizes energy loss.

### ◆ High Stiffness, Low Backlash

It features the high-stiffness HarmonicPlanetary<sup>®</sup> HPG series. Backlash is less than one minute (less than three minutes for size 11). The unique "thin-walled elastic internal gear" design ensures minimal backlash variation.

### ◆ Wide Speed-Torque Characteristics Allow for Various Operating Conditions

Reduction ratios range from 1/5 to 1/45. This allows for selection based on required speed and torque for a wide range of applications.

### ◆ 24-bit Absolute Encoder

It is equipped with a 24-bit absolute encoder that supports A-format<sup>®\*</sup> serial communication. The encoder features multi-turn counting, which is essential for actuators with speed reducers, and it maintains absolute position.

\* "A-format" is a registered trademark of Nikon Corporation.

### ◆ Quick-Lock Connector

It features a lever lock-type connector for easy wiring. The motor power cable and encoder signal cable connectors are integrated, enabling quick extension cable installation.

## Eliminating the Disadvantages of Orthogonal Shaft Planetary Gears

The optimal design of our proprietary planetary speed reducer and motor reduces the overall length and eliminates the disadvantages of orthogonal shaft planetary gears.

### The Reduced Overall Length Eliminates the need for an Orthogonal Gear

- Low Energy Loss
- Low Backlash

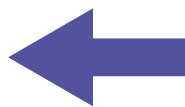

### Disadvantages of Orthogonal Gears

- High Energy Loss
- High Backlash

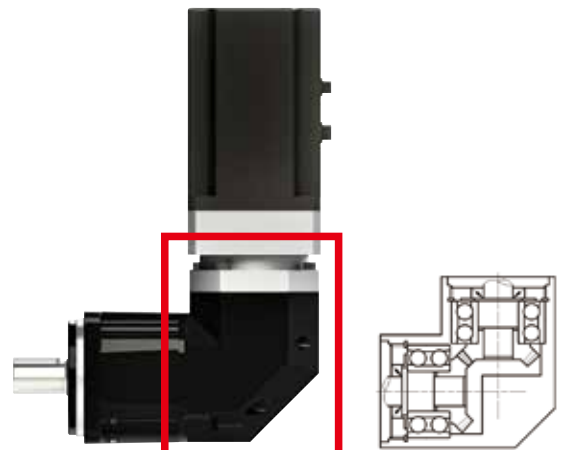

### Orthogonal Gear Section

Bearings for two shafts, oil seals, spiral bevel gears, and high-viscosity grease are required on the high-speed shaft side, resulting in high energy loss.

# Specifications

| Item   | Type  | FPA11A            | FPA14A                     |           |           | FPA20A               |           | FPA32A                 |           |      |
|--|---|-------------------|----------------------------|-----------|-----------|----------------------|-----------|------------------------|-----------|------|
|  |   | 05                | 11                         | 15        | 33        | 05                   | 11        | 21                     | 45        |      |
|  |   | F08A200           |                            |           |           | F12A200              |           |                        |           |      |
| Combined driver                                |   | HA-900A-3A-200    |                            |           |           | HA-900A-6A-200       |           |                        |           |      |
| Maximum torque <sup>*1</sup>                   | N·m   | 7.8               | 18                         | 23        | 23        | 32                   | 71        | 135                    | 294       |      |
| Limit for continuous torque <sup>*12</sup>     | N·m   | 2.3               | 5.0                        | 7.1       | 10        | 9.7                  | 20        | 40                     | 90        |      |
| Maximum speed <sup>*1</sup>                    | rpm   | 1200              | 545.4                      | 400       | 181.8     | 960                  | 436.3     | 228.5                  | 106.6     |      |
| Torque constant <sup>*1</sup>                  | N·m/A   | 1.7               | 3.7                        | 5.0       | 11.0      | 2.1                  | 4.6       | 8.8                    | 18.8      |      |
| Maximum current <sup>*1</sup>                  | A   | 5.8               | 6.1                        | 5.7       | 2.7       | 18                   | 18        | 18                     | 18        |      |
| Limit for continuous current <sup>*12</sup>    | A   | 1.8               | 1.8                        | 1.8       | 1.2       | 5.5                  | 5.1       | 5.3                    | 5.5       |      |
| Inductive voltage constant <sup>*3</sup>       | V/(rpm)   | 0.19              | 0.41                       | 0.56      | 1.2       | 0.23                 | 0.5       | 0.95                   | 2.0       |      |
| Phase resistance (20°C)                        | Ω   |                   | 1.4                        |           |           | 0.33                 |           |                        |           |      |
| Phase inductance                               | mH  |                   | 2.5                        |           |           | 1.4                  |           |                        |           |      |
| Moment of inertia <sup>*4</sup>                | GD <sup>2</sup> /4  | kg·m <sup>2</sup> | 0.0011                     | 0.0059    | 0.011     | 0.052                | 0.0096    | 0.045                  | 0.17      | 0.76 |
| Reduction ratio                                |   |                   | 1:5                        | 1:11      | 1:15      | 1:33                 | 1:5       | 1:11                   | 1:21      | 1:45 |
| Limit for moment load                          | N·m   | 9.5               | 32.3                       |           |           | 183                  |           | 452                    |           |      |
| Moment stiffness                               | N·m/rad   | 0.88              | 3.0 x 10 <sup>4</sup>      |           |           | 16.8x10 <sup>4</sup> |           | 42.1 x 10 <sup>4</sup> |           |      |
| Unidirectional positioning accuracy            | minutes   | 5                 | 4                          | 4         | 4         | 5                    | 4         | 4                      | 4         |      |
| Encoder type                                   |   |                   | Absolute encoder           |           |           |                      |           |                        |           |      |
| Encoder resolution                             | Single-turn detector  |                   | 2 <sup>24</sup> (16777216) |           |           |                      |           |                        |           |      |
|  | Multi-turn detector <sup>*5</sup>   |                   | 2 <sup>19</sup> (65536)    |           |           |                      |           |                        |           |      |
| Output shaft resolution                        | Pulse/Revolution  | 83886080          | 184549376                  | 251658240 | 553648128 | 83886080             | 184549376 | 352321536              | 754974720 |      |
| Weight <sup>*4</sup>                           | kg  | 1.6               | 2.2                        | 2.2       | 2.2       | 5.6                  | 5.8       | 7.4                    | 7.4       |      |
| Ambient environmental conditions <sup>*6</sup> | Use temperature: 0 to 40°C / Storage temperature: -20 to 60°C, Use humidity and storage humidity: 20 to 80%RH (non-condensing)<br>Vibration resistance: 25m/s <sup>2</sup> (frequency: 10 to 400 Hz) / impact resistance: 300 m/s <sup>2-7</sup><br>No dust, metal powder, corrosive gas, flammable gas, oil mist, or other similar material. Place indoors without being exposed to direct sunlight.<br>Altitude: 1000 m or less |                   |                            |           |           |                      |           |                        |           |      |
| Motor insulation                               | Insulation resistance: 100 MΩ or higher (500 VDC), Dielectric strength: 1500 VAC / 1 min, Heat resistance class: Class A  |                   |                            |           |           |                      |           |                        |           |      |
| Mounting direction                             | Can be installed in any direction.  |                   |                            |           |           |                      |           |                        |           |      |
| Protective structure                           | Totally enclosed self-cooled type (IP54)  |                   |                            |           |           |                      |           |                        |           |      |

The values in the table above show typical values.

\*1: They are typical characteristics in the case of combinations with our driver (driven with the ideal sine wave).

\*2: This is the value for saturated temperature when installed on the aluminum heatsink of the following size:

FPA11Axx-F08: 320x320x16 [mm], FPA14Axx-F08: 320x320x16 [mm], FPA20Axx-F12: 400x400x20 [mm], FPA32Axx-F12: 400x400x20 [mm]

\*3: The value of the phase MEF constant multiplied by 3.

\*4: Value for the flange output type. For the straight shaft type, refer to the technical material, "4-1 Options."

\*5: The range of the multi-turn detection is from -32768 to 32767.

\*6: For details, refer to the technical material "3-3 Installation location and installation work."

\*7: For test conditions, refer to technical materials "1-11 Impact resistance" and "1-12 Vibration resistance." This value is not ensured if vibrations or shocks are applied for hours or continuously.

\* The FPA11A will be released soon.

# Ordering Code

**FPA 14 A 11 F0 HG - F 08 A 200 - 32 S 24b A - C -**

(1) (2) (3) (4) (5) (6) (7) (8) (9) (10) (11) (12) (13) (14) (15) (16)

|     |                          |  |
|-----|--------------------------|--|
| (1) | Model name               | AC servo actuator FPA series   |
| (2) | Size                     | 11, 14, 20, 32   |
| (3) | Version symbol           | A  |
| (4) | Reduction ratio          | 05: 1/5 (Sizes 11 and 20)<br>11: 1/11 (Sizes 14 and 20)<br>15: 1/15 (Size 14)<br>21: 1/21 (Size 32)<br>33: 1/33 (Size 14)<br>45: 1/45 (Size 32)  |
| (5) | Output shaft form symbol | F0: (Sizes 11, 14, 20, 32) Flange output<br>J20: (Size 11) Straight shaft, no keyway<br>J60: (Size 11) Straight shaft, with key, with center tap<br>J2: (Sizes 14, 20, 32) Straight shaft, no keyway<br>J6: (Sizes 14, 20, 32) Straight shaft, with key, with center tap |
| (6) | Speed reducer type       | HG: Planetary Speed Reducer HPG series   |

These sizes apply when combined with our HA-900 driver.

For sizes when combined with drivers from other manufacturers, please contact us.

|      |   |   |
|------|---|---|
| (7)  | Motor version symbol                      | F   |
| (8)  | Motor size                                | 08: Size 11, 14<br>12: Size 20, 32  |
| (9)  | Brake (for holding)                       | A: Not equipped with a brake  |
| (10) | Input voltage of the applied servo driver | 200: 200V   |
| (11) | Encoder type                              | 32: A-format compliant,<br>Transmission rate: 4 Mbps, 1-to-1 connection   |
| (12) | Encoder type                              | S: Multi-turn absolute<br>(External battery backup system)  |
| (13) | Encoder resolution                        | 24b: 24-bit (16,777,216 pulses/revolution)  |
| (14) | Encoder phase angle                       | Phase difference between the induced voltage of the motor U phase and the absolute encoder origin<br>A: 0 degrees |
| (15) | Connector specification                   | C: Equipped with the the standard connector   |
| (16) | Special specifications                    | No symbol: Standard product<br>SP: Special-specification product  |

(Please inquire regarding UL compliance for special specifications and options.)

# External Dimensions

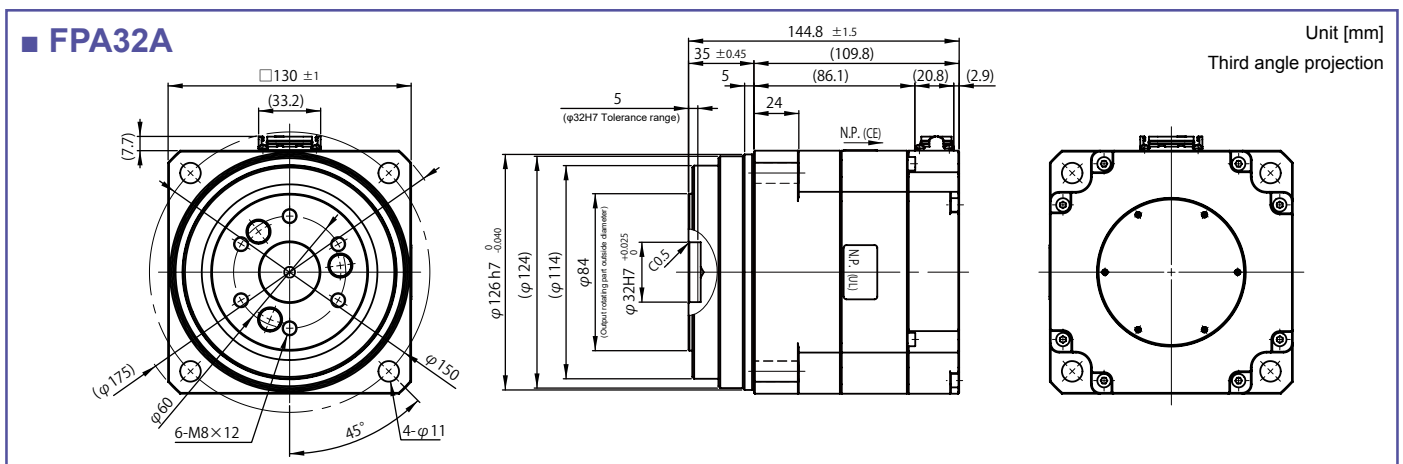
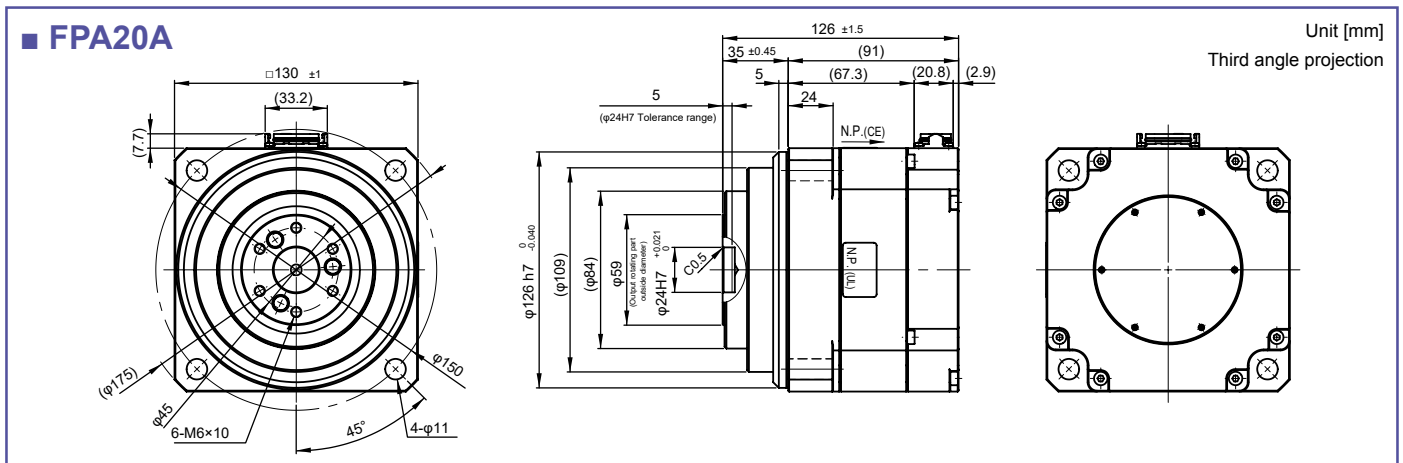
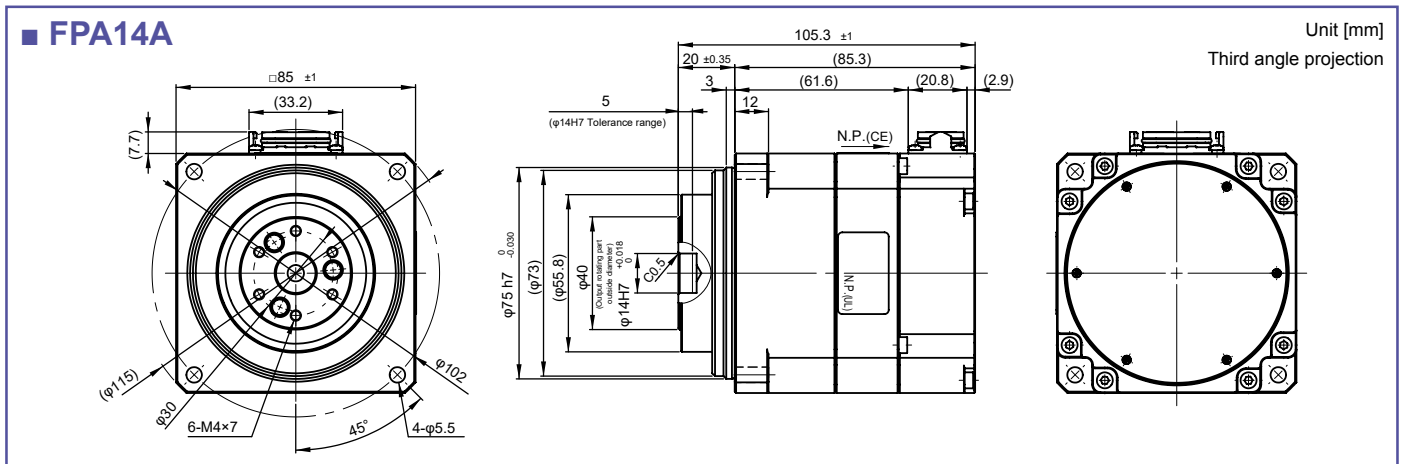
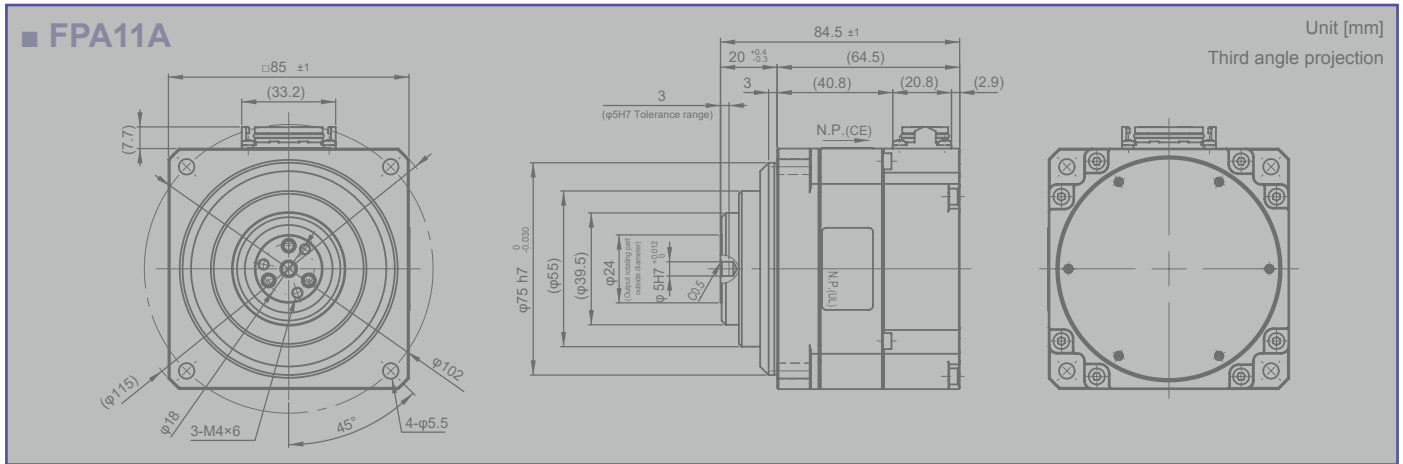

Note: For details of the external dimensions, refer to the delivery specification drawing issued by HDS. The tolerance varies depending on the manufacturing method (casting or machining) of the parts. For more information on the tolerance of a dimension without a tolerance, please contact us.  
\* The FPA11A will be released soon.

# Operable Range

- \* The data applies when it is combined with our HA-900 driver.
- \* The continuous operating range is the value obtained when mounted on an aluminum heat sink of the size shown in the upper right corner of the graph.
- \* This is the representative value for three-phase 200V.

## FPA11A

FPA11A05-F08

Heatsink: 320 x 320 x 16 [mm]

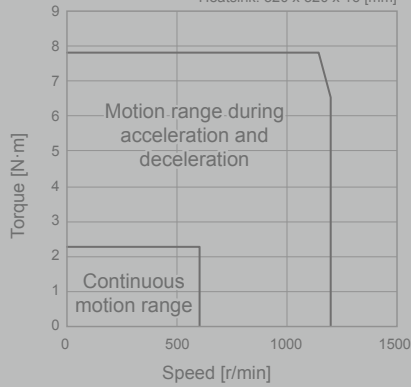

## FPA14A

FPA14A11-F08

Heatsink: 320 x 320 x 16 [mm]

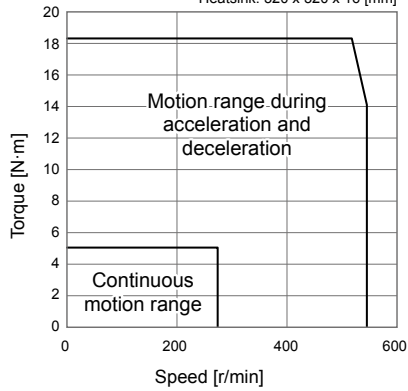

FPA14A15-F08

Heatsink: 320 x 320 x 16 [mm]

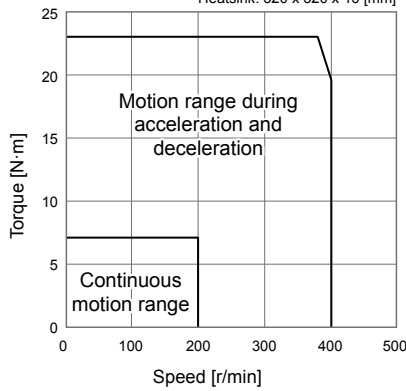

FPA14A33-F08

Heatsink: 320 x 320 x 16 [mm]

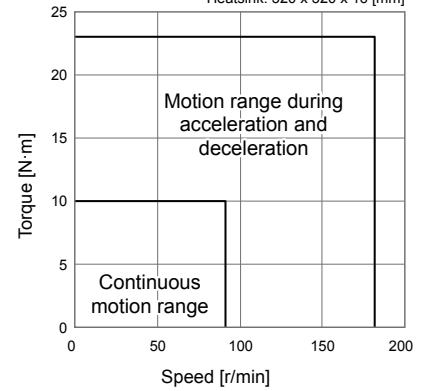

## FPA20A

FPA20A05-F12

Heatsink: 400 x 400 x 20 [mm]

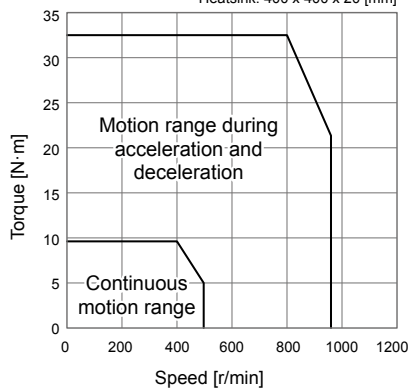

FPA20A11-F12

Heatsink: 400 x 400 x 20 [mm]

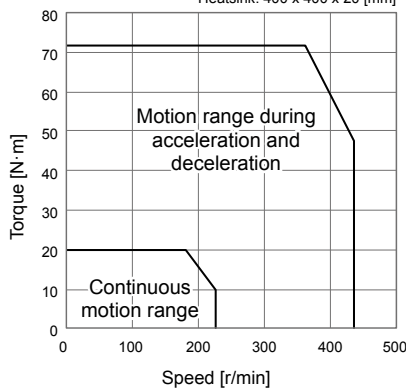

## FPA32A

FPA32A21-F12

Heatsink: 400 x 400 x 20 [mm]

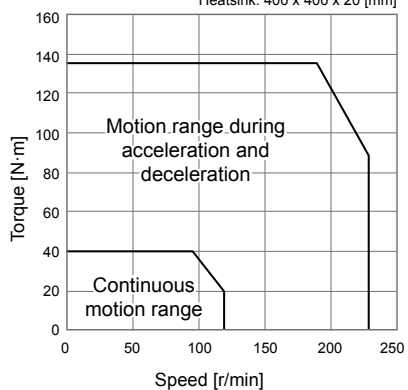

FPA32A45-F12

Heatsink: 400 x 400 x 20 [mm]

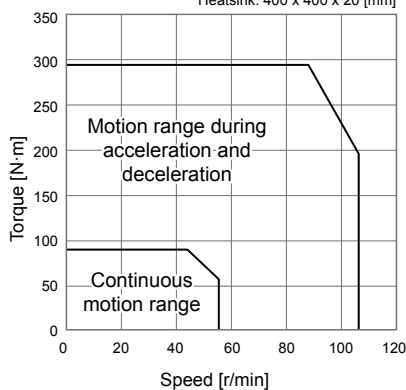

\* The FPA11A will be released soon.

# Mechanical Accuracy

The FPA series actuator output shaft and mechanical accuracy of the mounting flange are shown below:

Standard

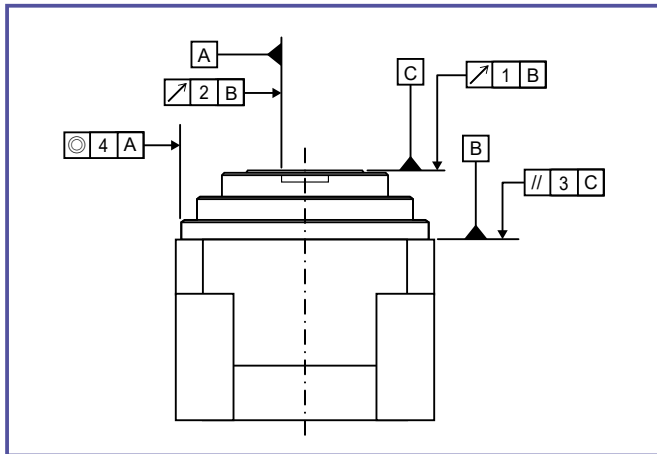

Unit: mm

| Accuracy Item   | FPA11A | FPA14A | FPA20A | FPA32A |
|---|--------|--------|--------|--------|
| 1. Output shaft surface runout                          | 0.020  | 0.020  | 0.020  | 0.020  |
| 2. Output shaft radial runout                           | 0.030  | 0.040  | 0.040  | 0.040  |
| 3. Parallelism between output shaft and mounted surface | 0.050  | 0.060  | 0.060  | 0.060  |
| 4. Concentricity between output shaft and fitting part  | 0.040  | 0.050  | 0.050  | 0.050  |

Note: Values are based on the Total Indicator Reading (T.I.R.).

\* The FPA11A will be released soon.

With Straight Shaft

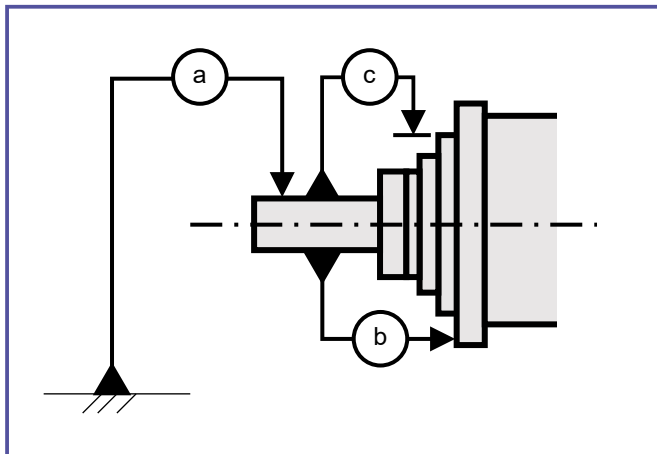

Unit: mm

| Accuracy Item  | FPA11A | FPA14A | FPA20A | FPA32A |
|--|--------|--------|--------|--------|
| a. Output shaft axial runout                                   | 0.030  | 0.040  | 0.040  | 0.040  |
| b. Surface runout of mounted surface                           | 0.050  | 0.060  | 0.060  | 0.060  |
| c. Concentricity between the output shaft and the fitting part | 0.040  | 0.050  | 0.050  | 0.050  |

Note 1: Values are based on the Total Indicator Reading (T.I.R.).

Note 2: For detailed dimensions of the actuator, refer to the delivery specification drawings.

Note 3: The output shaft has not been surface-treated.

\* The FPA11A will be released soon.

# Unidirectional Positioning Accuracy

"Unidirectional positioning accuracy" refers to the maximum value in one revolution of the values that are calculated from the difference between the actually revolved angle and the specified revolved angle from the standard position at each of the points positioned in the fixed rotational direction (JIS B 6201-1987). The FPA series incorporates the planetary gear speed reducer HarmonicPlanetary® HPG series, which reduces the effect of motor shaft positioning error to 1/reduction ratio.

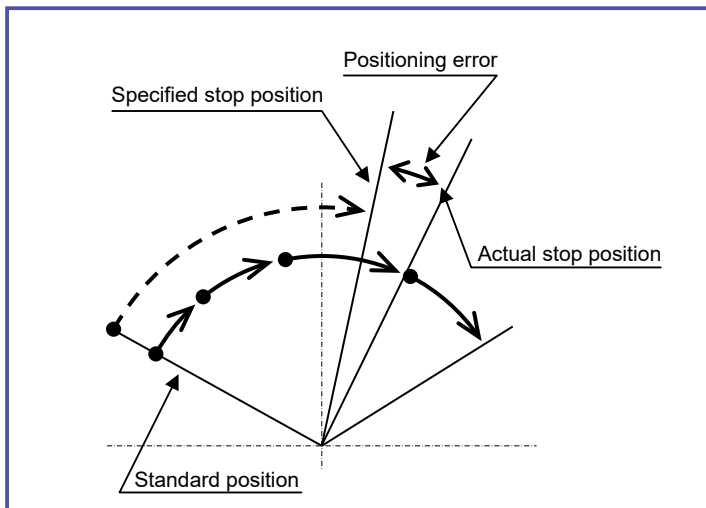

The "unidirectional positioning accuracy" for each size is shown below.

Units: minutes

| Reduction ratio | Type | FPA11A | FPA14A | FPA20A | FPA32A |
|-----------------|------|--------|--------|--------|--------|
| 1:5             |      | 5      | -      | 5      | -      |
| 1:11            |      | -      | 4      | 4      | -      |
| 1:15            |      | -      | 4      | -      | -      |
| 1:21            |      | -      | -      | -      | 4      |
| 1:33            |      | -      | 4      | -      | -      |
| 1:45            |      | -      | -      | -      | 4      |

\* The FPA11A will be released soon.

# Relay Cable

The relay cables connect the FPA series and the HA-900 series driver. The actuator-side connector combines the motor and encoder connections for quick installation. Please select one of the three specifications based on the cable exit direction. A relay cable is required for connecting the FPA series and the HA-900 series driver.

## Ordering Code

EWE-MBS ●● – HR0608A – TN4 – MDR14

●● Cable direction

MDR14 Cable length

| Symbol | Specifications                 |
|--------|--------------------------------|
| A      | (All sizes) Vertical exit type |
| B      | (All sizes) Rear exit type     |
| C      | (All sizes) Front exit type*   |

\* Size 11 requires cable bending space.

| Symbol | Specifications |
|--------|----------------|
| 02     | 2 m            |
| 05     | 5 m            |
| 10     | 10 m           |

## Installation Diagram/Outline Drawing

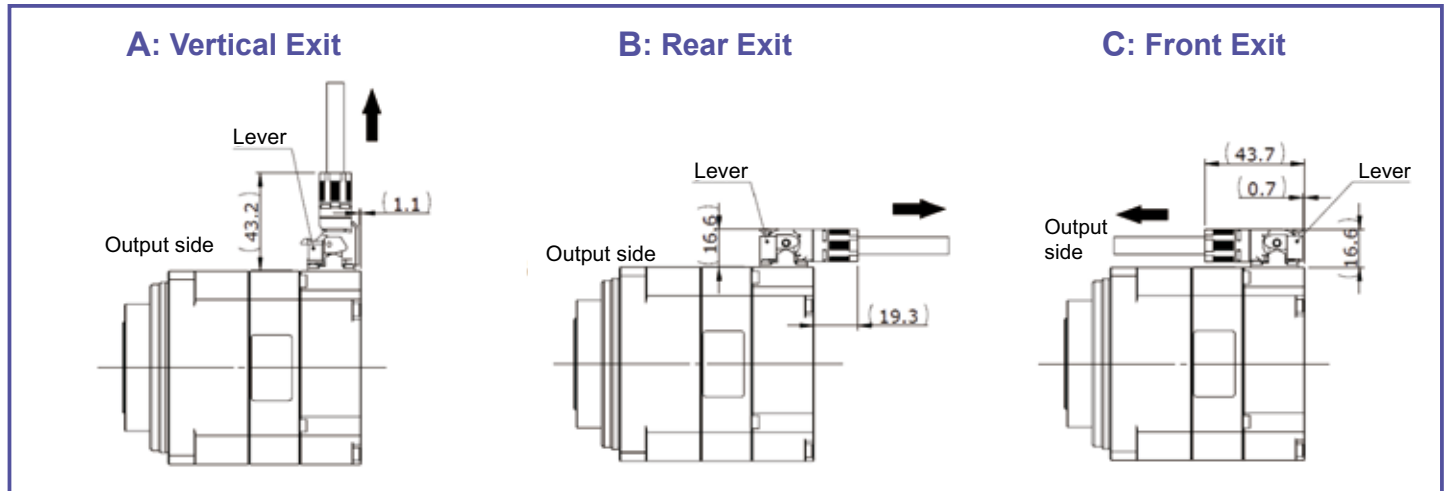

## Design and Installation Precautions

- Ensure that the cable is routed with a sufficient bending radius. (For fixed sections, use a bend radius of at least four times the cable diameter. For moving sections, use a bend radius of at least six times the cable diameter.)
- When using the front exit type, pay attention to the shape of customer-installed parts to ensure there is enough space for the cable to be routed properly. For size 11 in particular, the product mounting surface and the connector cable exit point are close together. If necessary, incorporate clearance into the customer parts.
- When attaching the relay cable connector to the actuator, visually confirm that the lever clicks into place securely so that the lever is surely locked.

# Options

With straight shaft (Output shaft form symbols: J20, J60, J2, J6)  
 Straight-type output shafts are available. They are assembled onto the product and shipped.

**Size 11** Unit [mm]

Third angle projection

\* Not available for J20 specifications

| Symbol | Specifications                            | Attachments                               |
|--------|---|---|
| J20    | Straight shaft, no keyway                 | -   |
| J60    | Straight shaft, with key, with center tap | Parallel key: 4h9x49x15L (single pointed) |

**Size 14** Unit [mm]

Third angle projection

\* Not available for J2 specifications

| Symbol | Specifications                            | Attachments                                |
|--------|---|--|
| J2     | Straight shaft, no keyway                 | -  |
| J6     | Straight shaft, with key, with center tap | Parallel key: 5h9x5h9x25L (single pointed) |

**Size 20** Unit [mm]

Third angle projection

\* Not available for J2 specifications

| Symbol | Specifications                            | Attachments                                 |
|--------|---|---|
| J2     | Straight shaft, no keyway                 | -   |
| J6     | Straight shaft, with key, with center tap | Parallel key: 8h9x7h11x36L (single pointed) |

**Size 32** Unit [mm]

Third angle projection

\* Not available for J2 specifications

| Symbol | Specifications                            | Attachments                                  |
|--------|---|--|
| J2     | Straight shaft, no keyway                 | -  |
| J6     | Straight shaft, with key, with center tap | Parallel key: 12h9x8h11x70L (single pointed) |

\* The straight shaft option for this product is assembled and shipped by HDSI. Since it cannot be locked in rotation, it is difficult for the customer to retrofit it.  
 \* The FPA11A will be released soon.

## Harmonic Drive LLC

### Boston US Headquarters

42 Dunham Ridge  
 Beverly, MA 01915  
 978.532.1800  
 www.HarmonicDrive.net

### New York Sales Office

100 Motor Parkway, Suite 116  
 Hauppauge, NY 11788

### California Sales Office

333 W. San Carlos Street, Suite 1070  
 San Jose, CA 95110

### Chicago Sales Office

137 N. Oak Park Ave., Suite 410  
 Oak Park, IL 60301

## Group Companies

### Harmonic Drive Systems, Inc.

6-25-3 Minami-Ohi, Shinagawa-ku  
 Tokyo 141-0013, Japan

### Harmonic Drive SE

Hoenbergstrasse, 14, D-65555  
 Limburg/Lahn Germany

Harmonic Drive is a registered trademark  
 of Harmonic Drive LLC.

