

RSF supermini Series

AC Servo Actuator Manual (RSF-3C and RSF-5B)

- Thank you very much for your purchasing our RSF supermini series servo actuator.
- Be sure to use sufficient safety measures when installing and operating the equipment so as to prevent an accident resulting in a serious physical injury damaged by a malfunction or improper operation.
- Product specifications are subject to change without notice for improvement purposes.
- Keep this manual in a convenient location and refer to it whenever necessary in operating or maintaining the units.
- The end user of the actuator should have a copy of this manual.



SAFETY GUIDE

For RSF supermini series, HA series
manufactured by Harmonic Drive Systems Inc



Read this manual thoroughly before designing the application, installation, maintenance or inspection of the actuator.



WARNING

Indicates a potentially hazardous situation, which, if not avoided, could result in death or serious personal injury.



CAUTION

Indicates a potentially hazardous situation, which, if not avoided, may result in minor or moderate personal injury and/or damage to the equipment.

LIMITATION OF APPLICATIONS:

The equipment listed in this document may not be used for the applications listed below:

- | | |
|----------------------------------|--|
| * Space equipment | * Amusement equipment |
| * Aircraft, aeronautic equipment | * Machine or devices acting directly on the human body |
| * Nuclear equipment | * Instruments or devices to transport or carry people |
| * Household apparatus | * Apparatus or devices used in special environments |
| * Vacuum equipment | * Instruments or devices to prevent explosion |
| * Automobile, automotive parts | |





Safety measures are essential to prevent accidents resulting in death, injury or damage of the equipment due to malfunction or faulty operation.

Precautions when using a direct drive motor

CAUTIONS FOR DIRECT DRIVE MOTOR AT APPLICATION DESIGNING





 CAUTION Always use under followings conditions: <input type="checkbox"/> The motor is designed to be used for indoor. - Ambient temperature: 0°C to 30°C - Ambient humidity: 20% to 80%RH (Non-condensation) - Vibration: No vibration - No contamination by water, oil - No corrosive or explosive gas	 CAUTION Follow exactly the instructions to install the actuator in the equipment. - Ensure exact alignment of motor shaft center and corresponding center in the application. - Failure to observe this caution may lead to vibration, resulting in damage of output shaft.
--	--

CAUTION FOR DIRECT DRIVE MOTOR IN OPERATIONS





 CAUTION Keep limited torques of the actuator. - Keep limited torques of the actuator. - Be aware to balance the gravity for load mounting to output shaft.	 WARNING Never connect cables directly to a power supply socket. - Direct drive motor cannot be operated unless it is connected to dedicated driver. - Never connect it to commercial power supply directly. Direct drive motor may be damaged and causes fire.
 CAUTION Do not apply shocks to actuator. - Do not apply shocks because direct drive motor is directly connected to high precision encoder. - If the encoder is damaged, it may cause uncontrollable operation.	 CAUTION Avoid handling of motor by cables. - Failure to observe this caution may damage the wiring, causing uncontrollable or faulty operation of direct drive motor.

Precautions when using a driver

CAUTIONS FOR DRIVERS AT APPLICATION DESIGNING

 CAUTION Always use drivers under followings conditions: - Mount in a vertical position keeping sufficient distance to other devices to let heat generated by the driver radiate freely. - Ambient temperature: 0°C to 50°C - Ambient humidity: less than 90% RH (Non condensation) - No vibration or shocks - No dust, dirt, corrosive, inflammable or explosive gas	 CAUTION Use sufficient noise suppressing means and safe grounding. - Keep signal and power leads separated. - Keep leads as short as possible. - Ground actuator and driver at one single point, minimum ground resistance class: D (less than 100 ohms) - Do not use a power line filter in the motor circuit.
 CAUTION Pay attention to negative torque by inverse load. - Inverse load may cause damages of direct drive motor. - Please consult our sales office, if you intent to apply products for inverse load.	 CAUTION Use a fast-response type ground-fault detector designed for PWM inverters. - Do not use a time-delay-type ground-fault detector.

CAUTION FOR DRIVERS IN OPERATIONS

 WARNING Never change wiring while power is active. - Make sure of power non-active before servicing the products. - Failure to observe this caution may result in electric shock or personal injury.	 WARNING Do not touch terminals at least 5 minutes after turning OFF power. - Otherwise, residual electric charges may result in electric shock. Wait for 5 min or more before inspection. - Make installation of products not easy to touch their inner electric components.
 CAUTION Do not make a voltage resistance test or megger test. - Failure to observe this caution may result in damage of the control unit. - Please consult our sales office, if you intent to make a voltage resistance test.	 CAUTION Do not operate control units by means of power ON/OFF switching. - Frequent power ON/OFF may result in deterioration of internal circuit elements. - Start/stop operation should be performed via input signals.

DISPOSAL OF DIRECT DRIVE MOTOR, A MOTOR, A CONTROL UNIT AND/OR THEIR PARTS

 CAUTION All products or parts have to be disposed of as industrial waste. - Since the case or the box of drivers have a material indication, classify parts and dispose them separately.
--

Contents

Chapter 1 Overview of the RSF supermini series	6
1-1 Major characteristics.....	6
1-2 Ordering information	7
1-3 Combinations with drivers	7
1-4 Specifications of RSF supermini actuators.....	8
1-5 External dimensions of actuators	9
1-6 One-way positioning accuracy.....	11
1-7 Torsional stiffness.....	12
1-8 Detector resolution	13
1-9 Mechanical accuracy	13
1-10 Allowable load	14
1-10-1 Allowable radial load and allowable thrust load	14
1-10-2 Radial load when the operating point is different.....	14
1-11 Rotary direction	15
1-12 Impact resistance	15
1-13 Vibration resistance	15
1-14 Torque-speed characteristics	16
1-15 Cable specifications.....	18
Chapter 2 Selection of the RSF supermini Series.....	19
2-1 Allowable load moment of inertia.....	19
2-2 Variable load inertia	19
2-3 Verifying loads	19
2-4 Duty cycles	20
2-4-1 Actuator speed	20
2-4-2 Load moment of inertia	20
2-4-3 Load torque	20
2-4-4 Acceleration time and deceleration time.....	21
2-4-5 Calculating equivalent duty.....	22
2-4-6 Effective torque and average speed	26
2-4-7 Permissible overloaded time	27
Chapter 3 Installing the actuator.....	28
3-1 Receiving Inspection	28
3-2 Notice on handling.....	29

3-3	Location and installation	30
3-3-1	Environment of location	30
3-3-2	Considerations into External Noise.....	30
3-3-2	Installation	31
Chapter 4	Motor shaft retention brake(RSF-5B)	32
4-1	Motor shaft retention brake specifications	32
4-2	Controlling the brake power supply	32
4-2-1	Using a relay cable (Recommended method)	32
4-2-2	Not using a relay cable	33
Chapter 5	Options	34
5-1	Extension cables	34
5-2	Connectors	36
Appendix 1	Conversion of Unit	37
Appendix 2	Moment of inertia	39
1.	Calculation of mass and moment of inertia	39
2.	Moment of inertia of circular cylinder	41

Chapter 1 Overview of the RSF supermini series

The RSF supermini servo actuators utilize zero backlash Harmonic Drive® precision gears, a brushless servo motor and an incremental encoder to deliver precision motion control.

Actuators with an electromagnetic brake are also included in the lineup. They can meet fail-safe requirements of equipment to prevent accidents upon power supply failure.

The RSF supermini series can contribute to downsizing of driving of robot joints, semiconductor/LCD panel manufacturing equipment, machine tools, and other FA equipment. By utilizing its small and high-torque characteristics, it can also be used for small equipment and for research.

1-1 Major characteristics

◆ Small, lightweight, and high-torque

The RSF supermini series with the Harmonic Drive® CSF mini series gear realizes a high torque and has a very high output torque for the outer dimensions compared to the direct driving method with a high-capacity motor alone.

Also, combination with the dedicated AC servo motor realizes size and weight reduction that were previously unachievable.

◆ Standard lineup of actuators with a brake (only RSF-5B)

The standard lineup of AC servo actuators includes the deenergisation operation type actuators with an electromagnetic brake for the first time for this size of actuators.

Fail-safe requirements of equipment can be met to prevent accidents upon power failure without providing any external brake or changing the equipment structure to install a brake.

◆ Superior positioning precision

Zero backlash and exceptional positioning accuracy.

◆ Stable controllability

The high deceleration gear ratio of the speed reducer provides stable controllability for large variations of load moment of inertia.

1-2 Ordering information

Model codes for the RSF supermini series actuators are as follows:

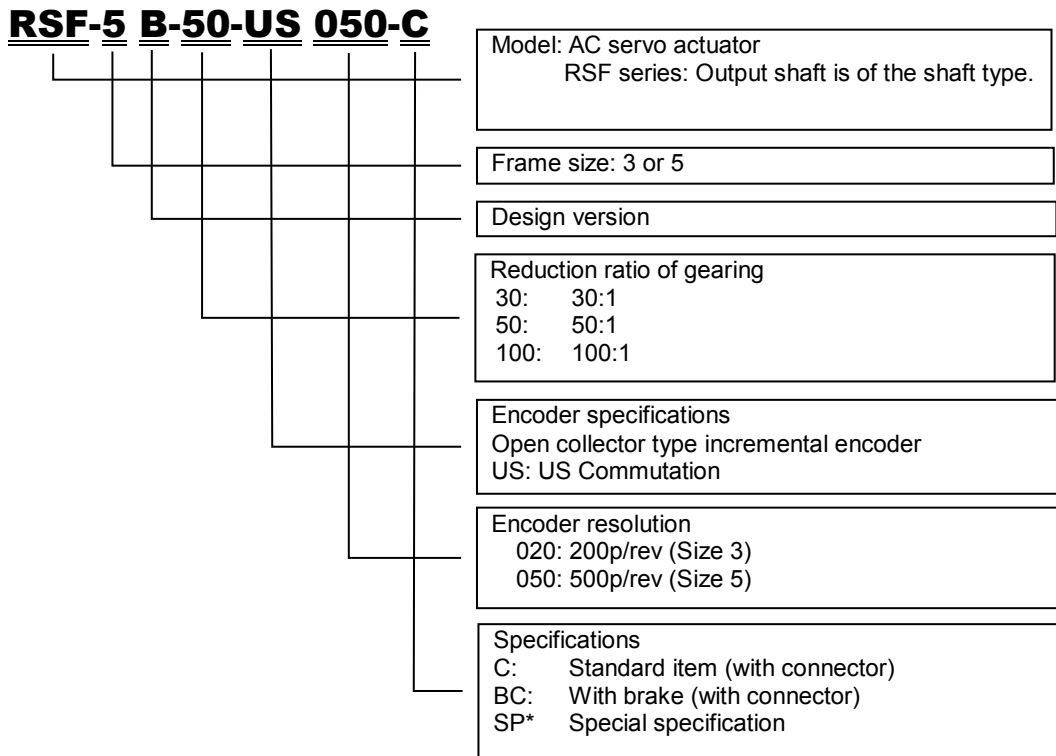

1-3 Combinations with drivers

The RSF supermini series actuators are used in combination with the DCJ, DDP, DEP and HA-680 drivers.

Drivers can perform position control, speed control, and torque control.

For details of the drivers, refer to the “driver manual or data sheet”.

Extension cables are required for connection between the actuator and the driver.

1-4 Specifications of RSF supermini actuators

Specifications of actuators are as follows:

Time rating:	Continuous	Service temperature:	0~40°C
Excitation method:	Permanent magnet type	Storage temperature:	-20~+60°C
Insulation class:	B	Service/ storage temp.:	20~80%RH (no condensation)
Withstanding voltage:	AC500V/min	Vibration resistance:	49m/s ²
Insulation resistance:	DC500V 100MΩor more	Lubricant:	Grease (Harmonic Grease)
Structure:	Totally enclosed self cooling type		

Item	Model	RSF-3C			RSF-5B			
		30	50	100	30	50	100	
Power supply voltage(diver)	V	DC24±10%			DC24±10%			
Allowable continuous current	A	0.65	0.66	0.56	1.11	0.92	0.76	
Allowable continuous torque (during operation at allowable continuous rotation speed)	Nm	0.03	0.07	0.11	0.18	0.29	0.44	
	Kgf cm	0.31	0.68	1.08	1.83	2.95	4.48	
Allowable continuous rotation speed (output shaft)	rpm	150	90	45	150	90	45	
Allowable continuous stall torque	Nm	0.04	0.08	0.12	0.28	0.44	0.65	
	Kgf cm	0.41	0.82	1.22	2.85	4.48	6.62	
Instantaneous maximum current	A	1.5	1.4	1.1	2.3	2.2	1.7	
Max. torque	Nm	0.13	0.21	0.30	0.5	0.9	1.4	
	Kgf cm	1.27	2.05	2.94	5.1	9.17	14.3	
Max. speed	rpm	333	200	100	333	200	100	
Torque constant	N m/A	0.11	0.18	0.40	0.3	0.54	1.1	
	Kgf cm /A	1.12	1.84	4.08	3.06	5.51	11.22	
EMF constant	V/(rpm)	0.015	0.025	0.05	0.04	0.07	0.13	
Phase resistance (at 20°C)	Ω	1.34			0.82			
Phase inductance	mH	0.18			0.27			
Moment of inertia Note 4	GD ² /4	Kg m ²	0.11×10 ⁻⁴	0.29×10 ⁻⁴	1.17×10 ⁻⁴	0.66×10 ⁻⁴ (0.11×10 ⁻³)	1.83×10 ⁻⁴ (0.31×10 ⁻³)	7.31×10 ⁻⁴ (1.23×10 ⁻³)
	J	Kgf cm s ²	1.07×10 ⁻⁴	2.98×10 ⁻⁴	11.90×10 ⁻⁴	0.67×10 ⁻³ (1.13×10 ⁻³)	1.87×10 ⁻³ (3.15×10 ⁻³)	7.45×10 ⁻³ (12.6×10 ⁻³)
Gear ratio		30	50	100	30	50	100	
Allowable radial load (output shaft central value)	N	36			90			
	kgf	3.6			9.1			
Allowable thrust load	N	130			270			
	kgf	13.2			27.5			
Encoder pulses (motor shaft)	Pulse/	200			500			
Encoder resolution (Output shaft: when multiplied by 4)	Note 5	Pulse/ Rotation	24,000	40,000	80,000	60,000	100,000	200,000
	Motor shaft brake	Input power supply voltage	V			DC24±10%		
	Retention torque	Nm	-			0.18	0.29	0.44
		Kgf cm	-			1.83	2.95	4.48
Mass Note 5	Without brake	g	31.0(except clamp filter)			66.0(except clamp filter)		
	With brake	g	-			86.0(except clamp filter)		
Recommended drivers	DC24V	DCJ-055-09, DDP-090-09, DEP-090-09			HA-680-4B-24			
		HA-680-4B-24			HA-680-4B-24			

Note 1: The table shows typical output values of actuators.

Note 2: the values in the table above are obtained when it is combined with the combined driver.

Note 3: All values are typical.

Note 4: The moment of inertia is the total value of the motor shaft and Harmonic Drive® gear moment of inertia values converted to the output side. The values in parentheses are for equipment with a brake.

Note 5: The encoder resolution is (motor shaft encoder resolution when multiplied by 4) x (gear ratio).

Note 6: The weight of clamp filter is 6 gram for each.

1-5 External dimensions of actuators

The external drawings are shown as follows:

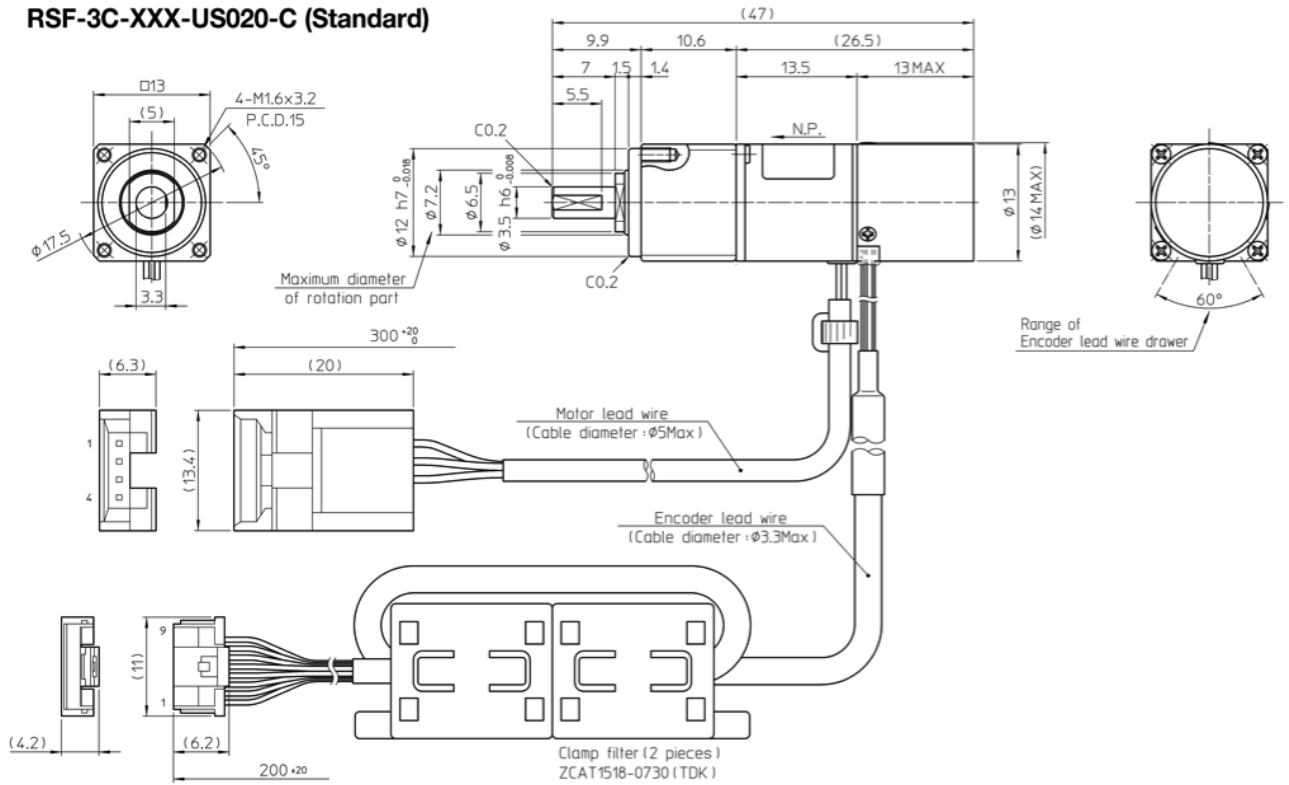

Note) For detailed outside dimensions, check the delivery specification drawing issued by us.

RSF-5B-XXX-US050-C (Standard)

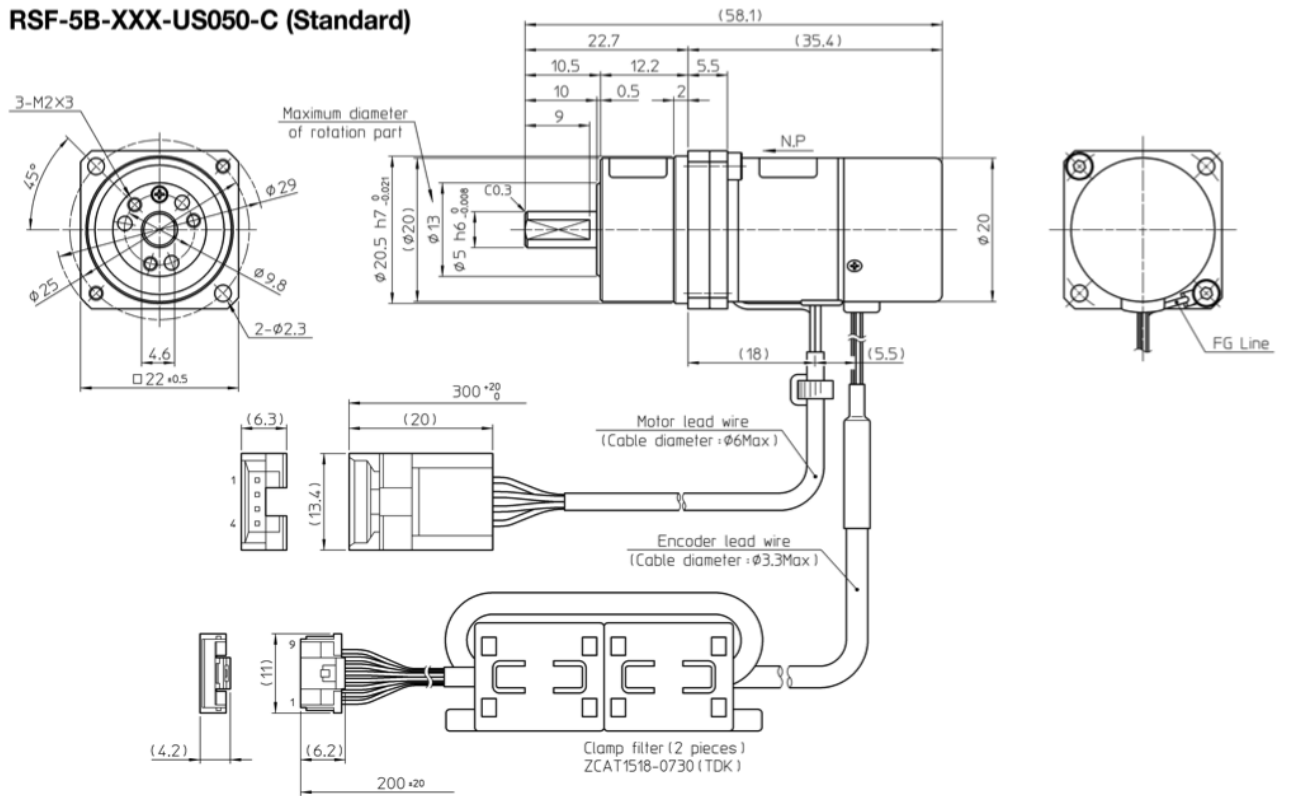

RSF-5B-XXX-US050-BC (With Brake)

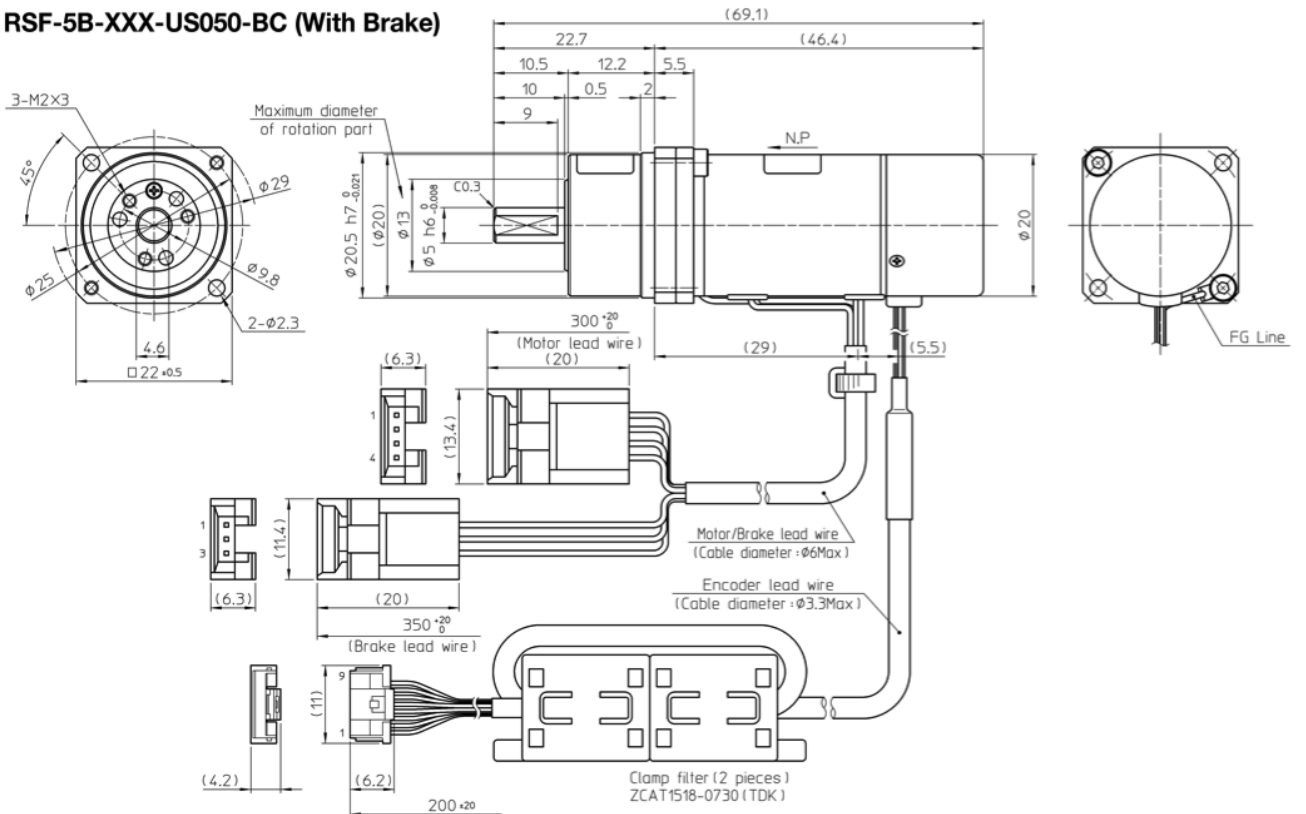

Note) For detailed outside dimensions, check the delivery specification drawing issued by us.

1-6 One-way positioning accuracy

The following table shows the “one-way positioning accuracy” and “repeated positioning accuracy.” The following table contains representing values. (JIS B 6201:1987)

The one-way positioning accuracy of RSF supermini actuators is almost equal to the angular positioning accuracy of the Harmonic Drive® gearing, because the effect on the positioning error of the built-in motor is reduced to its 1/30 or 1/50 or 1/100 by the gearing.

The accuracy for each gear ratio is shown below.

Mode		RSF-3C			RSF-5B		
Item	Gear ratio	30	50	100	30	50	100
One-way positioning accuracy	arc min	10			4	3	3
	rad	2.9×10^{-3}			1.20×10^{-3}	0.87×10^{-3}	0.87×10^{-3}

■ Reference

(Accuracy display and measurement method according to JIS B 6201: 1987)

● One-way positioning of rotation shaft motion

First, perform positioning at any one position in a fixed direction. This position is the reference position. Next, perform positioning in succession in the same direction, and measure the difference between the angle actually rotated from the reference position and the desired angle at each position. The maximum difference in one rotation among these values is taken as the measurement value. Measurement of equipment with the continuous positioning function for rotational motion shall be done once per 30 degrees or 12 positions throughout the entire rotation range as a rule.

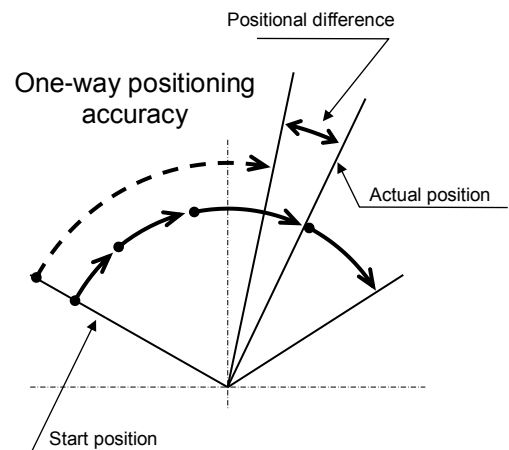

1-7 Torsional stiffness

When a torque is applied to the output flange of the actuator with the motor locked, the resulting torsional wind up is near proportional to the torque.

The upper right figure shows the torsional stiffness characteristics of the output flange applying torque starting from zero to plus side [+T₀] and minus side [-T₀]. This trajectory is called torque-torsion characteristics which typically follows a loop 0→A→B→A'→B'→A as illustrated. The torsional stiffness of the RSF supermini actuator is expressed by the slope of the curve that is a spring rate (wind-up) (unit:N·m/rad).

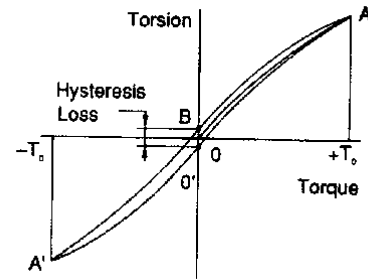

The torsional stiffness may be evaluated by dividing torque-torsion characteristics curve into three major regions. The spring rate of each region is expressed K₁, K₂, and K₃ respectively.

K₁: spring rate for torque region 0-T₁

K₂: spring rate for torque region T₁-T₂

K₃: spring rate for torque region over T₂

The wind-up for each region is expressed as follows:

- ◆ wind-up for torque region 0-T₁: $\varphi = \frac{T}{K_1}$
- ◆ wind-up for torque region T₁-T₂: $\varphi = \theta_1 + \frac{T - T_1}{K_2}$
- ◆ wind-up for torque region over T₂: $\varphi = \theta_2 + \frac{T - T_2}{K_3}$

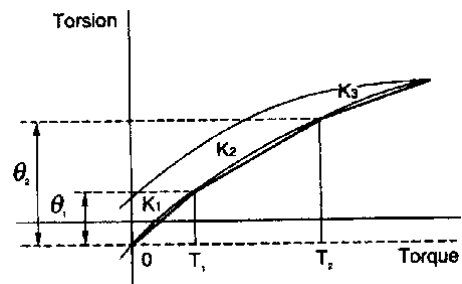

The following table shows average values of T₁ through T₃, K₁ through K₃, and θ_1 through θ_2 for different gear ratios.

Model		RSF-3C			RSF-5B		
		30	50	100	30	50	100
T ₁	Nm	0.016	0.016	0.016	0.075	0.075	0.075
	Kgf m	0.0016	0.0016	0.0016	0.0077	0.0077	0.0077
K ₁	Nm/rad	27	30	34	90	110	150
	Kgf m/arc min	0.0008	0.0009	0.0010	0.003	0.003	0.004
θ_1	x10 ⁻⁴ rad	5.9	5.3	4.7	8.7	6.9	5
	arc min	2.0	1.8	1.6	3	2.4	1.7
T ₂	Nm	0.05	0.05	0.05	0.22	0.22	0.22
	Kgf m	0.005	0.005	0.005	0.022	0.022	0.022
K ₂	Nm/rad	40	47	54	110	140	180
	Kgf m/arc min	0.0012	0.0014	0.0016	0.003	0.004	0.005
θ_2	x10 ⁻⁴ rad	12.5	10.6	9.3	22	18	13
	arc min	4.2	3.6	3.1	7.5	6	4.4
K ₃	Nm/rad	51	57	67	120	170	200
	Kgf m/arc min	0.0015	0.0017	0.0020	0.004	0.005	0.006

1-8 Detector resolution

An encoder with 200 pulses for RSF-3C, 500 pulses for RSF-5B per rotation is incorporated in the motor unit of the RSF supermini series actuators, and the motor output is decelerated by 30:1, 50:1, or 100:1 by the Harmonic Drive® speed reducer. Therefore, the resolution per one rotation of the actuator output shaft is 30, 50, or 100 times of the actual encoder resolution. In addition, the encoder signal is electrically multiplied by 4.

The following table shows the resolution at the output shaft for different gear ratios.

Model		RSF-3C			RSF-5B		
Gear ratio		30	50	100	30	50	100
Item							
Detector resolution (when multiplied by 4)	Pulse/Rotation	24,000	40,000	80,000	60,000	100,000	200,000
Angle per one pulse	Angle second (arc sec)	54	32.4	16.2	21.6	12.96	6.48

1-9 Mechanical accuracy

The machining accuracy of the output flange and the mounting flange of RSF supermini actuators are indicated in the table below.

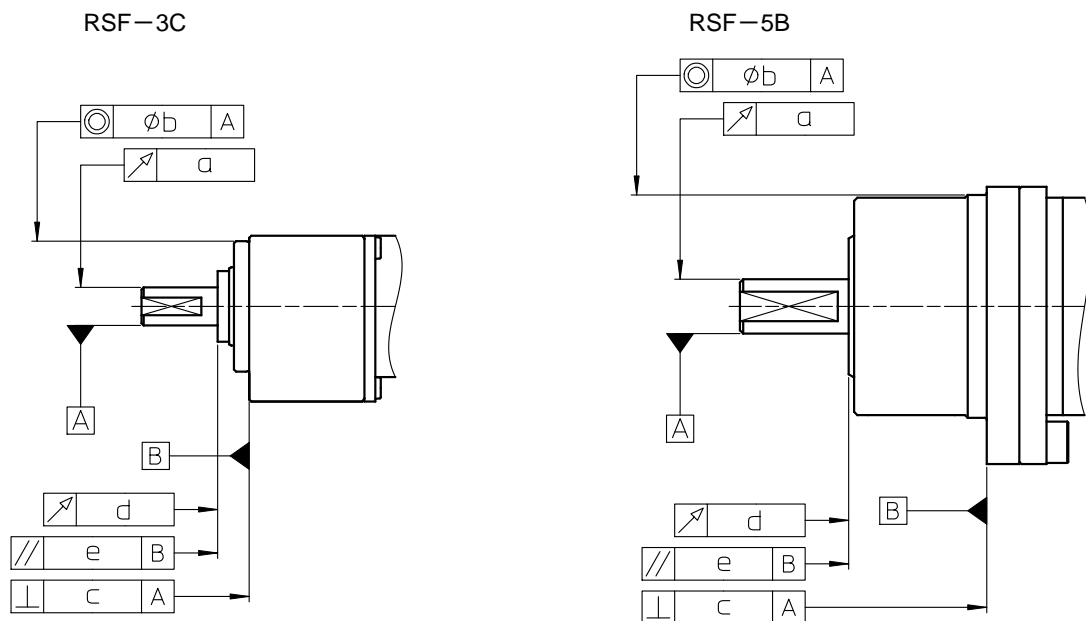

Machined accuracy of the output flange * T.I.R. unit: mm

Symbol Model	Machined parts	Accuracy value	
		RSF-3C	RSF-5B
a	Runout of the tip of the output shaft	0.03	0.03
b	Concentricity of installed spigot joint	0.02	0.04
c	Squareness of installation surface	0.02	0.02
d	Output flange surface contact	0.005	0.005
e	Parallelism of installation surface and output flange	0.015	0.015

*) T.I.R(Total Indicator Reading): Indicates the total amount of dial gage reading when the measurement unit is rotated once.

1-10 Allowable load

1-10-1 Allowable radial load and allowable thrust load

The gear head used in the RSF supermini series incorporates the high-precision 4-point contact ball bearing for direct support of external load (output part).

The allowable radial load and thrust load of the output shaft are shown below.

The allowable radial load F_r is obtained with respect to the center ($L/2$) 0 point of the output shaft.

The values in the following table are designed by considering the life of the bearing.

The allowable values must not be exceeded.

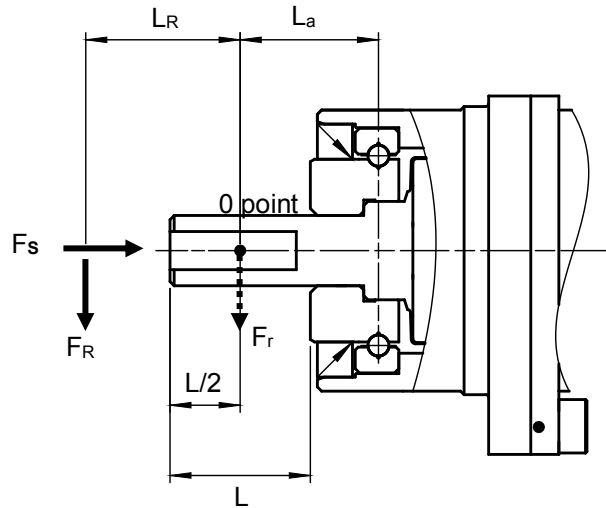

Model	Unit	RSF-3C	RSF-5B
Allowable radial load (F_r)	N	36	90
	kgf	3.6	9.1
Allowable thrust load (F_s)	N	130	270
	kgf	13	27

1-10-2 Radial load when the operating point is different

If the operating point of radial load is different, the allowable radial load value is also different.

The relation between radial load position L_R and allowable radial value F_R is obtained from the following formula.

The allowable values must not be exceeded.

$$F_R = \frac{L_a}{L_a + L_R} F_r$$

F_R : Allowable radial load at distance L_R from the 0 point [N]

F_r : Allowable radial load at the 0 point [N]

L_a : Distance from the bearing starting point to the 0 point [mm]

L_R : Distance from the position where radial load is exerted to the 0 point [mm]

L : Shaft length [mm]

Model		RSF-3C	RSF-5B
Allowable radial load (F_r)	N	36	90
	kgf	3.6	9.1
L_a	mm	8.6	9.85
L	mm	7	10

1-11 Rotary direction

The rotary direction of the RSF supermini series actuators when a forward rotation command is given from the driver is forward rotation seen from the output shaft side (i.e. counterclockwise: CW).

The rotary direction can be switched by using the Parameter → “driver” setting.

“20: Rotary direction command” setting

Value	FWD command	REV command	Setting
0	FWD rotation	REV rotation	Default
1	REV rotation	FWD rotation	

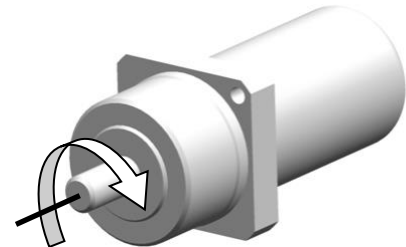

FWD: CW rotation

* The model shape is RSF-5B. RSF-3A is also the same.

* For details of the driver, refer to “AC Servo Driver HA-680 Series Technical Data.”

1-12 Impact resistance

The impact resistance of the actuators is as follows.

Impact acceleration: 300 m/s^2

Direction: top/bottom, right/left, front/back

Repeating times: three

However, do not apply impact to the output shaft.

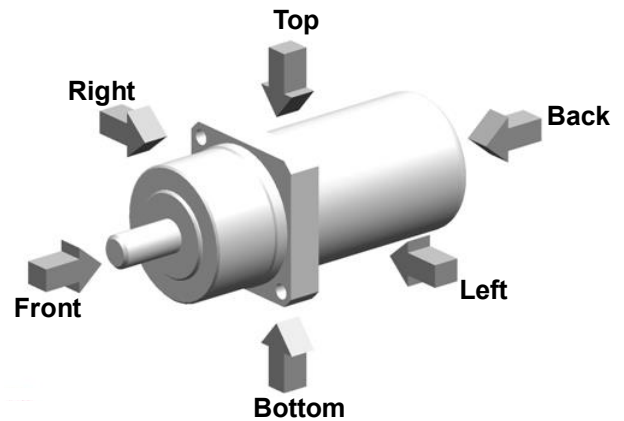

Impact resistance

1-13 Vibration resistance

The vibration resistance of the actuators for up/down, left/right, and front/back is as follows.

Vibration acceleration: 49 m/s^2 (5G)

Frequency: 10~400Hz

This specification does not guarantee fretting wear of mechanism components due to micro vibrations.

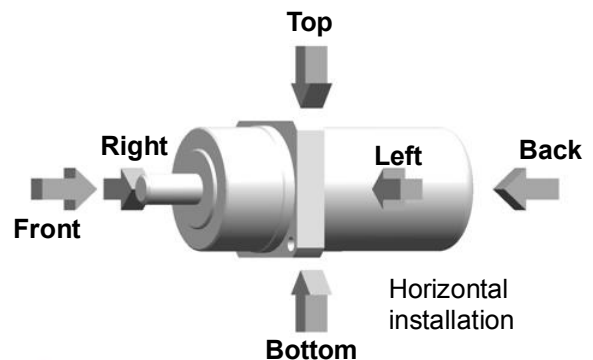

Vibration resistance

1-14 Torque-speed characteristics

The following graphs show the usable ranges of the RSF supermini series actuators.

- Acceleration and deceleration range:
The range allows instantaneous operation like acceleration and deceleration, usually.
- Continuous duty range:
The range allows continuous operation for the actuator.
- 50% duty range:
The range allows the 50% duty time operation of a cycle time.

RSF-3C-30-US020-C

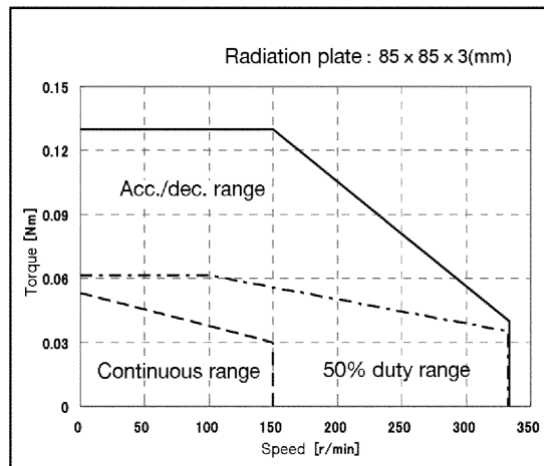

RSF-3C-50-US020-C

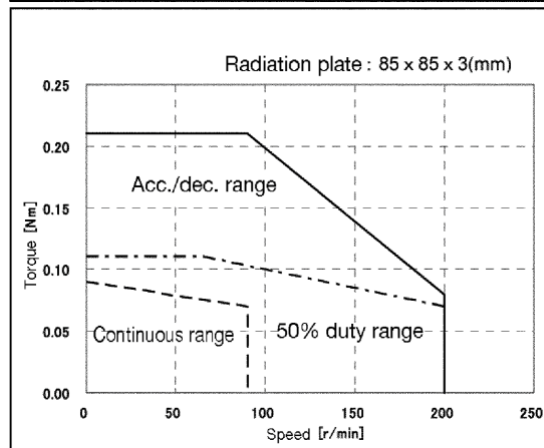

RSF-3C-100-US020-C

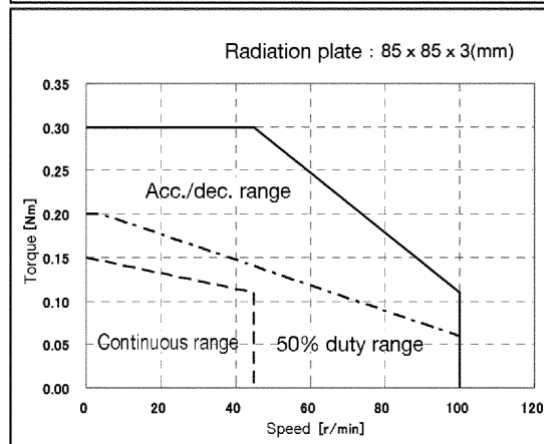

Note: The values of the graph are obtained when the aluminum radiation plate shown at the upper right of the graph.

Note: Even in the continuous range, if it is used continuously in one direction, please consult with us.

RSF-5B-30-US050-C,
RSF-5B-30-US050-BC

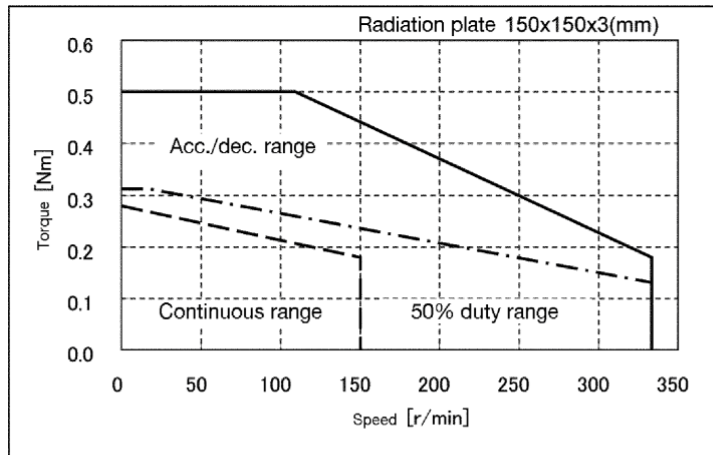

RSF-5B-50-US050-C,
RSF-5B-50-US050-BC

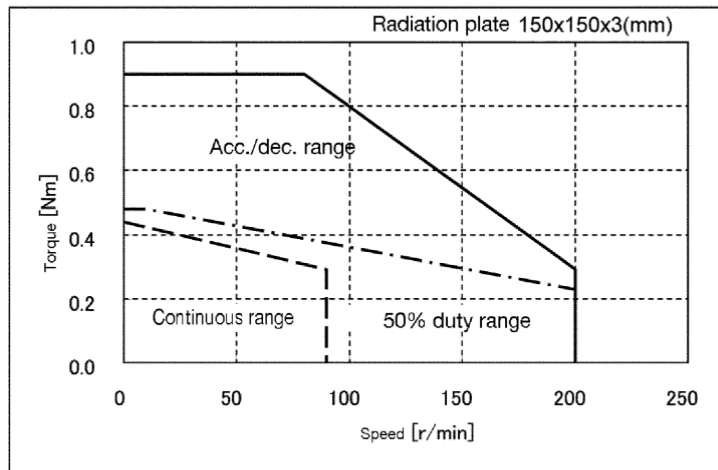

RSF-5B-100-US050-C,
RSF-5B-100-US050-BC

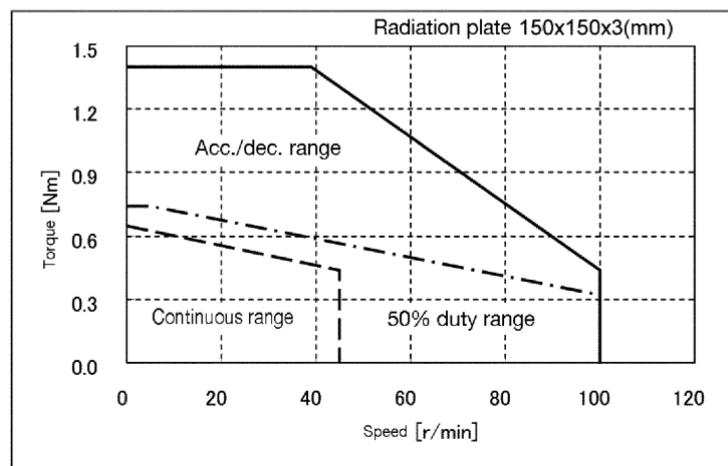

Note: The values of the graph are obtained when the aluminum radiation plate shown at the upper right of the graph.

Note: Even in the continuous range, if it is used continuously in one direction, please consult with us.

1-15 Cable specifications

The following tables show specifications of the cable for the motor and the encoder of the RSF supermini actuators.

Motor cable

Pin No.	Color	Signal name	Remark
1	Red (RED)	U	Motor phase-U
2	White (WHT)	V	Motor phase-V
3	Black (BLK)	W	Motor phase-W
4	Green (GRN)	FG	Grounding

Connector used	Housing:	PALR-04VF (with retainer)
	Contact:	S(B)PAL-001T-P0.5
Recommended connector	Housing:	PARP-04V (with retainer)
	Contact:	S(B)PA-001T-P0.5

Manufactured by J.S.T. Mfg Co., Ltd

Brake lead wire

Pin No.	Line color
1	Blue (BLU)
2	Yellow (YEL)
3	Gray (GRY)

Connector used	Housing:	PALR-03VF (with retainer)
	Contact:	S(B)PAL-001T-P0.5
Recommended connector	Housing:	PARP-03V (with retainer)
	Contact:	S(B)PA-001T-P0.5

Manufactured by J.S.T. Mfg Co., Ltd

Encoder lead wire

Pin No.	Color	Signal name	Remark
1	White (WHT)	A	A phase output
2	Green (GRN)	B	B phase output
3	Yellow (YEL)	Z	Z phase output
4	Brown (BRW)	U	U phase output
5	Blue (BLU)	V	V phase output
6	Orange (ORG)	W	W phase output
7	Red (RED)	+5V	Power supply input
8	Black (BLK)	GND	Power supply input
9			

Housing: NSHR-09V-S

Contact: SSSL-003T-P0.2

Manufactured by J.S.T. Mfg Co., Ltd

Chapter 2 Selection of the RSF supermini Series

2-1 Allowable load moment of inertia

To make full use of high precision and high performance of the RSF supermini series actuator, perform temporary selection by considering the load moment of inertia and rotation speed.

As a guideline, the load moment of inertia should be 3 to 5 times the moment of inertia of the actuator. For the moment of inertia of the actuator, refer to “1-4 Specifications of RSF supermini actuators.”

Refer to appendix 1 for the calculation of moment inertia.

The rotation speed cannot exceed the maximum rotation speed of the actuator. For the maximum rotation speed, refer to “1-4 Specifications of RSF supermini actuators.”

2-2 Variable load moment of inertia

RSF supermini series actuators include Harmonic Drive® gearing that has a high reduction ratio. Because of this there are minimal effects of variable load moment of inertias to the servo drive system. In comparison to direct servo systems this benefit will drive the load with a better servo response.

For example, assume that the load moment of inertia increases to N-times during its motion (for example, robot arms). The effect of the variable load moment of inertia to the [total inertia converted into motor shaft] is as follows:

The symbols in the formulas are:

J_s :	total moment of inertia converted into motor shaft	L :	Ratio of load moment of inertia to motor inertia
J_M :	moment inertia of motor	N :	variation ratio of load moment of inertia
R :	reduction ratio of RSF supermini series		

Direct drive

$$\text{Before: } J_s = J_M(1+L) \quad \text{After: } J_s' = J_M(1+NL) \quad \text{Ratio: } J_s'/J_M = \frac{1+NL}{1+L}$$

RSF supermini actuator drive

$$\text{Before: } J_s' = J_M\left(1 + \frac{L}{R^2}\right) \quad \text{After: } J_s' = J_M\left(1 + \frac{NL}{R^2}\right) \quad \text{Ratio: } J_s'/J_M = \frac{1+NL/R^2}{1+L/R^2}$$

In the case of the RSF supermini actuator drive, as the reduction ratio is [R=30], [R=50], or [R=100] and the square of the reduction ratio [R²=900], [R²=2500], or [R²=10000] the denominator and the numerator of the ratio are almost [1]. Then the ratio is [F=1]. This means that drive systems are hardly affected by the load moment of inertia variation. Therefore, it is not necessary to take the load moment of inertia variation in consideration for selecting an RSF supermini actuator or for setting up the HA-680 driver.

2-3 Verifying loads

The RSF supermini series incorporates a precision 4-point contact ball bearing for direct support of external load. To make full use of the performance of the RSF supermini series, check the maximum load moment, life of the 4-point contact ball bearing, and static safety factor.

For detailed calculation methods for the maximum load moment, life of the 4-point contact ball bearing, and static safety factor, refer to the “Harmonic Drive® CSF Mini series” catalogue.

2-4 Duty cycles

When a duty cycle includes many frequent start and stop operations, the actuator generates heat by big starting and braking current. Therefore, it is necessary to study the duty cycle profile.

The study is as follows:

2-4-1 Actuator speed

Calculate the required RSF supermini actuator speed (r/min) to drive the load.

$$\text{Rotary speed (r/min)} = \frac{\text{Liner speed (mm/min)}}{\text{Pitch of screw(mm)}}$$

For linear motion, convert with the formula below:

Select a reduction ratio from [30], [50] and [100] of an RSF supermini actuator of which the maximum speed is more than the required speed.

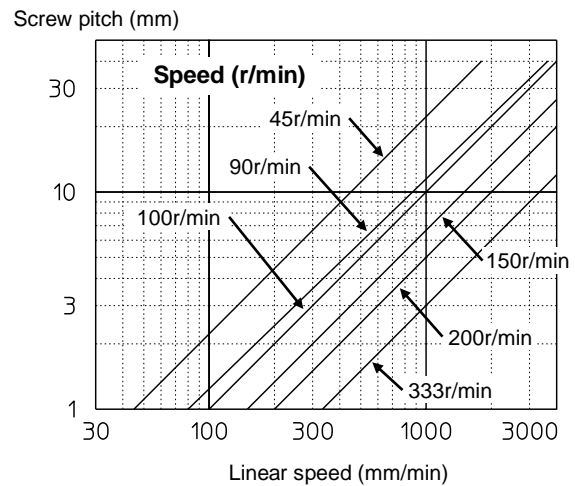

2-4-2 Load moment of inertia

Calculate the load moment of inertia driven by the RSF supermini series actuator.

Refer to appendix 1 for the calculation.

Tentatively select an RSF supermini actuator referring to section [2-1 allowable load moment of inertia] with the calculated value.

2-4-3 Load torque

Calculate the load torque as follows:

◆ Rotary motion

The torque for the rotating mass [W] on the friction ring of radius [r] as shown in the figure to the right.

$$T = 9.8 \times \mu \times W \times r$$

T: torque (Nm)

μ : coefficient of friction

W: mass (kg)

r: radius of friction face (m)

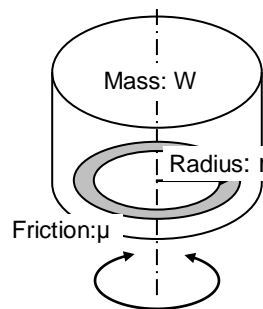

The load torque is restricted by the allowable load of the actuator (refer to "1-10 Allowable load") and load moment of inertia as well as by the load driven by the actuator.

Examine them carefully before using the actuator.

Horizontal linear motion

The following formula calculates the torque for horizontal linear motion of mass [W] fed by the screw of pitch [P].

$$T = 9.8 \times \mu \times W \times \frac{P}{2 \times \pi}$$

- T: torque (Nm)
- μ : coefficient of friction
- W: mass (kg)
- P: screw pitch (m)

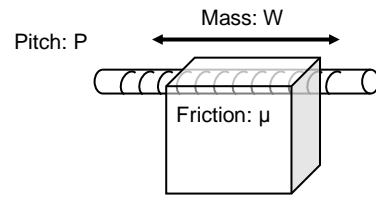

Vertical linear motion

The following formula calculates the torque for vertical linear motion of mass [W] fed by the screw of pitch [P].

$$T = 9.8 \times W \times \frac{P}{2 \times \pi}$$

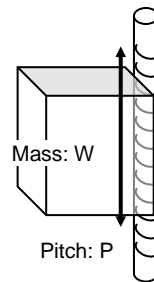

2-4-4 Acceleration time and deceleration time

Calculate acceleration and deceleration times for the selected actuator.

$$\text{Acceleration: } t_a = (J_A + J_L) \times \frac{2 \times \pi}{60} \times \frac{N}{T_M - T_L} \quad (1)$$

$$\text{Deceleration: } t_d = (J_A + J_L) \times \frac{2 \times \pi}{60} \times \frac{N}{T_M + 2 \times T_F - T_L} \quad (2)$$

- T_a: acceleration time (sec)
- T_d: deceleration time (sec)
- J_A: actuator inertia (kg·m²)
- J_L: load moment of inertia (kg·m²)
- N: actuator speed (r/min)
- T_M: maximum torque of actuator (Nm)
- T_L: load torque (Nm)

note that the polarity of the load torque is plus (+) for counter direction of revolution, and minus (-) for same direction.

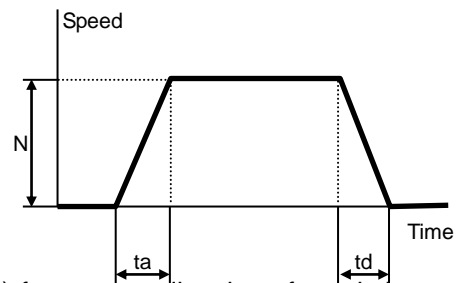

The friction torque of the actuator T_F (Nm) can also be obtained from the following formula:

$$T_F = K_T \times I_M - T_M \quad (3)$$

- K_T : Torque constant [Nm/A]
- I_M : Maximum current [A]

• Example: 1

The load conditions are:

- Rotary speed: 140r/min
- Load moment of inertia: $0.9 \times 10^{-3} \text{ kg} \cdot \text{m}^2$
- Load torque is so small as to be neglected.
- Acceleration/deceleration time is 0.03sec (30msec) or less.

- (1) Compare these conditions with the “1-4 Specifications of RSF supermini actuators” and temporarily select RSF-5B-50.
- (2) Obtain $J_A=1.83 \times 10^{-4} \text{ kg} \cdot \text{m}^2$, $T_M = 0.9 \text{ Nm}$, $K_T=0.54 \text{ Nm/A}$, and $I_M = 2.2 \text{ A}$ from “1-4 Specifications of RSF supermini actuators.”
- (3) The friction torque of the actuator is $T_F = 0.54 \times 2.2 - 0.9 = 0.29 \text{ Nm}$ from Formula (3) on the previous page.
- (4) Therefore, the shortest acceleration time and deceleration time can be obtained from Formula (1) and Formula (2), as follows:

$$t_a = (0.183 \times 10^{-3} + 0.9 \times 10^{-3}) \times 2 \times \pi / 60 \times 140 / 0.9 = 0.018 \text{ sec (18msec)}$$

$$t_d = (0.183 \times 10^{-3} + 0.9 \times 10^{-3}) \times 2 \times \pi / 60 \times 140 / (0.9 + 2 \times 0.29) = 0.011 \text{ s (11msec)}$$

- (5) Because the assumed acceleration/deceleration time is 0.03sec (30msec) or less, the temporarily selected actuator can be used for acceleration/deceleration, based on the result of (4).
- (6) If the calculation results of the acceleration/deceleration time do not fall within the desired time range, examine them again as follows.
 - Try to reduce the load moment of inertia.
 - Re-examine the gear ratio and gear head model.

2-4-5 Calculating equivalent duty

The load conditions, which are torque, speed, moment of inertia, acceleration/deceleration time, loading time, are limited by the actuator to drive the load. To select the proper actuator, the equivalent duty of the load should be calculated.

The %ED (percent equivalent duty) is:

$$\%ED = \frac{K_{La} \times t_a + K_{Lr} \times t_r + K_{Ld} \times t_d}{t} \times 100 \quad (4)$$

- where, t_a : acceleration time in second
 t_d : deceleration time in second
 t_r : driving time in second
 t : single cycle time in second
 K_{La} : duty factor for acceleration time
 K_{Lr} : duty factor for driving time
 K_{Ld} : duty factor for deceleration time

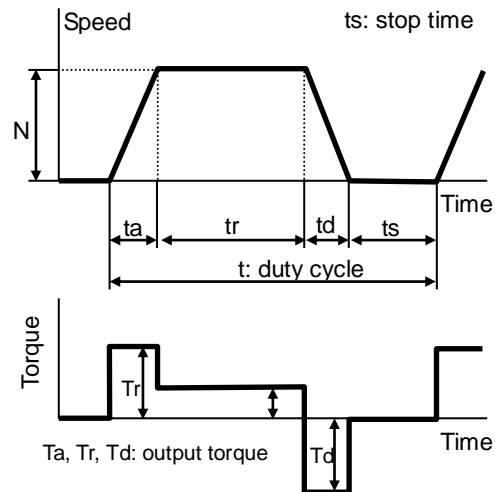

- Example 2: getting duty factors of K_{La} , K_{Lr} and K_{Ld}

As a result of Calculation Example 1 shown below, the selected actuator RSF-5B-50 works fine, so RSF-5B-50 can be used for duty factor graphs.

Operation conditions:

- The inertial load is accelerated at the maximum torque of the actuator, and decelerated at the maximum torque after operation at a fixed speed.
- The movement angle θ of one cycle is 120° .
- The duration of one cycle is 0.4 (s).
- The other conditions are the same as Calculation Example 1.

- (1) K_{La} and K_{Ld} : The average speed during the rotation speed change from 0 to 140r/min is 70r/min. From the duty factor graphs, $K_{La}=K_{Ld}\approx 1.5$ can be obtained.
- (2) K_{Lr} : $Tr\approx 0$ for the inertial load. Similarly, from the duty factor graphs, $K_{Lr}\approx 0.29$ can be read.
- (3) The movement angle can be obtained from the area in the "Rotation speed-Time" diagram above. In other words, the movement angle θ can be expressed as follows:

$$\theta = (N / 60) \times \{tr + (ta + td) / 2\} \times 360$$

Solving the formula above for tr (operation time at a fixed speed of N), the following can be obtained.

$$tr = \theta / (6 \times N) - (ta + td) / 2$$

Substituting $\theta = 120^\circ$ and $ta=0.03(s)$, $td=0.03(s)$, and $N= 140r/min$ from Example 1, $tr=0.113(s)$.

- (4) Because the cycle time is 0.4(s), the %ED is obtained as follows:

$$\%ED = (1.5 \times 0.03 + 0.29 \times 0.113 + 1.5 \times 0.03) / 0.4 \times 100 = 30.7\%$$

Because the value of %ED obtained is below 100, continuous repeated operation of this cycle can be done.

If the %ED is exceeded 100%, correct the situation by:

- Changing the speed-time profile
- Reducing load moment of inertia

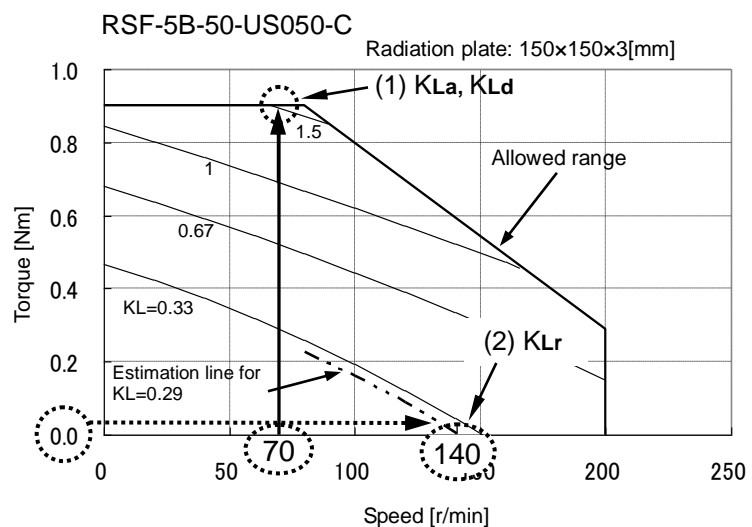

Graphs of duty factor

RSF-3C-30-US020-C

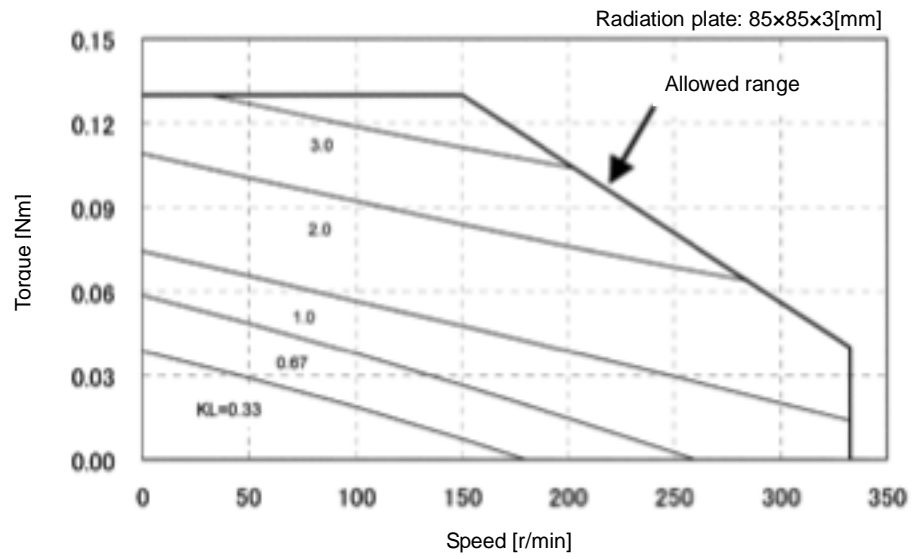

RSF-3C-50-US020-C

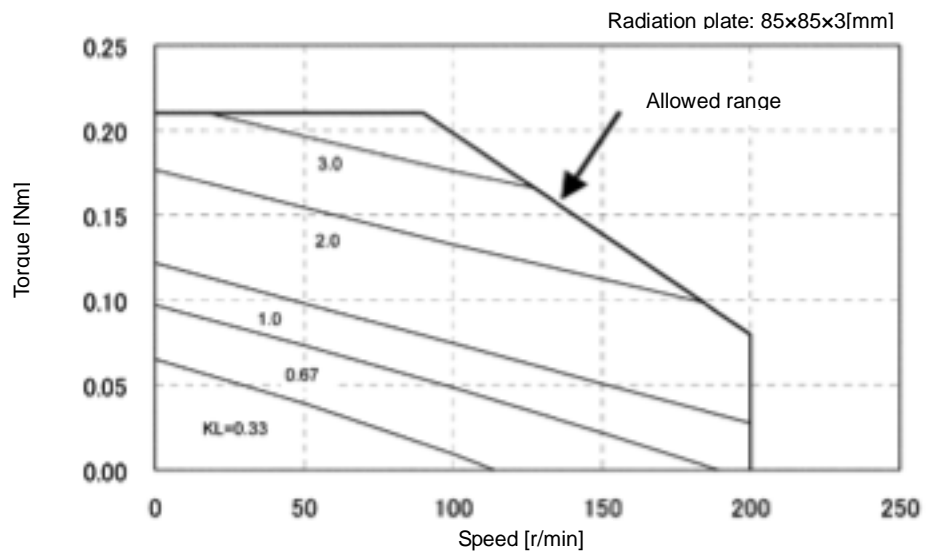

RSF-3C-100-US020-C

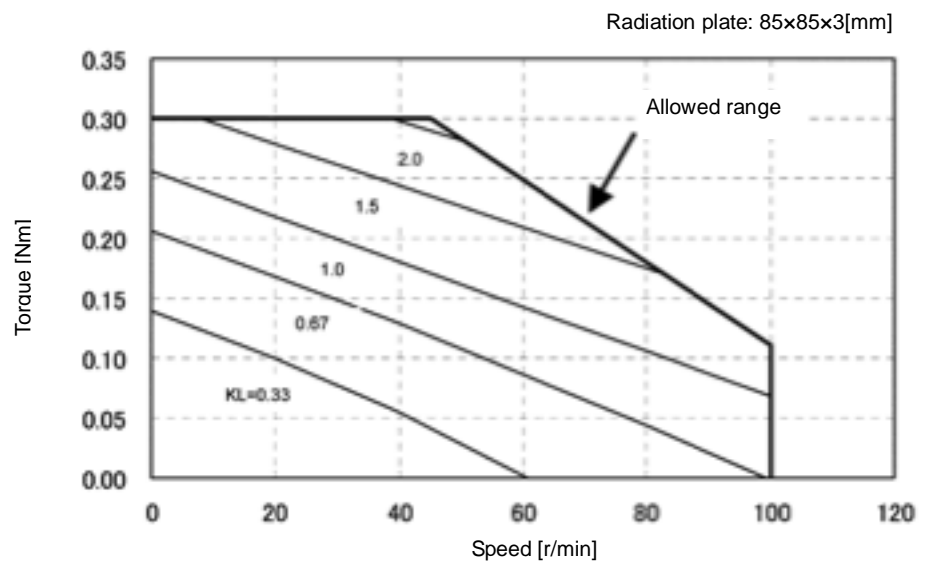

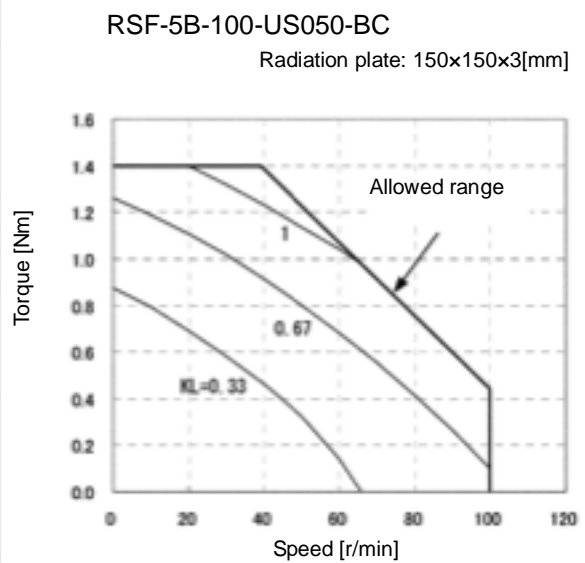
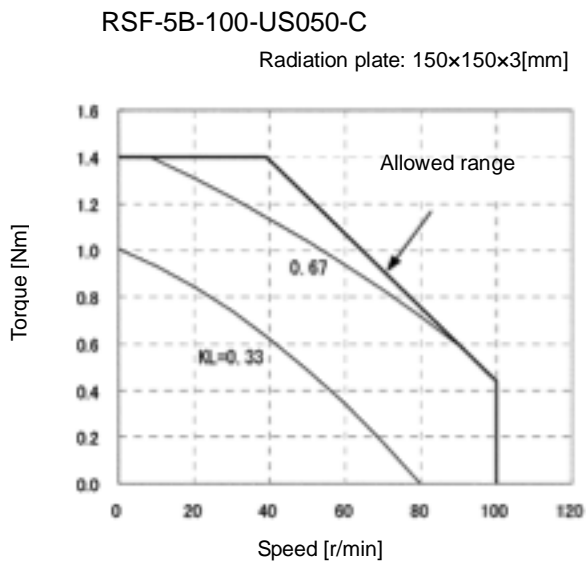
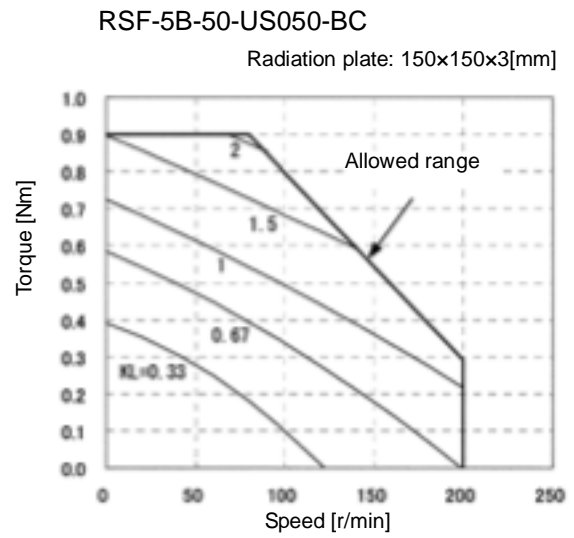
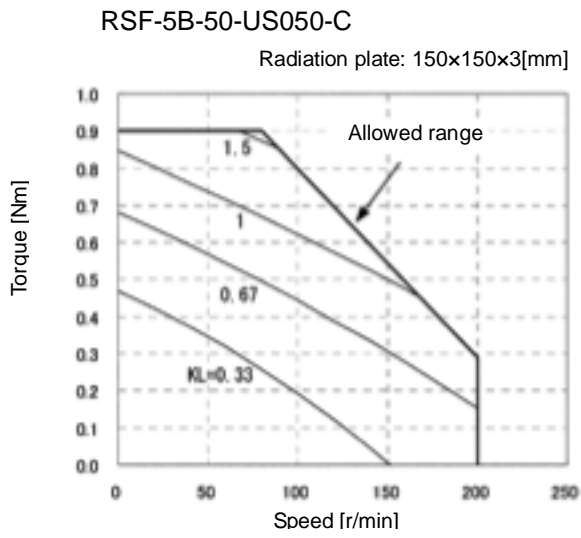
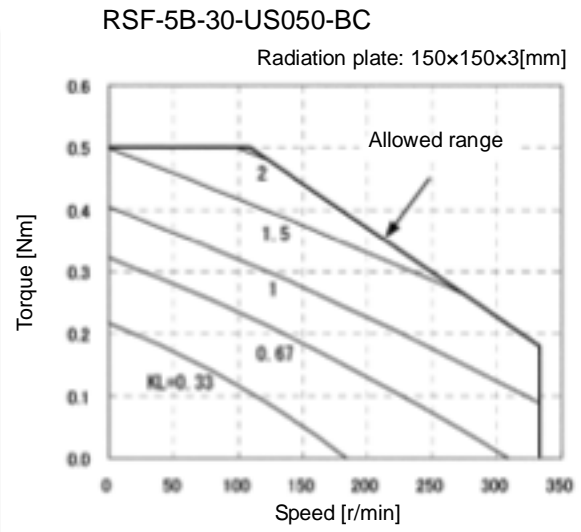
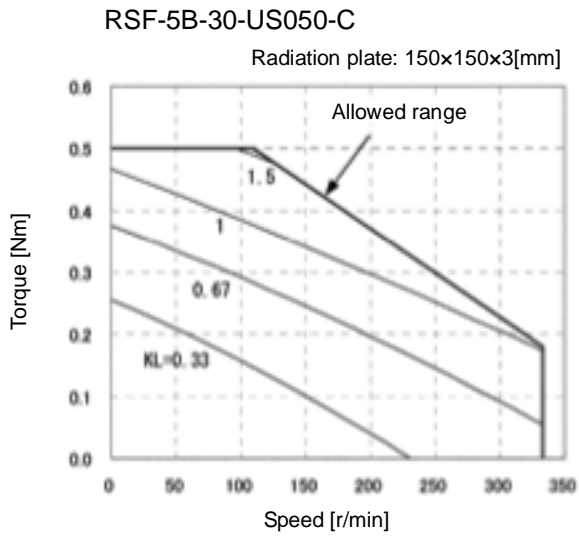

2-4-6 Effective torque and average speed

Additionally to the former studies, the effective torque and the average speed should be studied.

- (1) The effective torque should be less than allowable continuous torque specified by the driver.
- (2) The average speed should be less than allowable continuous speed of the actuator.

Calculate the effective torque and the average speed of an operating cycle as shown in "2-4-5 Calculating equivalent duty".

$$T_m = \sqrt{\frac{T_a^2 \times (t_a + t_d) + T_r^2 \times t_r}{t}}$$

$$N_{av} = \frac{N/2 \times t_a + N \times t_r + N/2 \times t_d}{t}$$

T_m : effective torque (Nm)
 T_a : maximum torque (Nm)
 T_r : load torque (Nm)
 t_a : acceleration time (s)
 t_d : deceleration time (s)
 t_r : running time at constant speed (s)
 t : time for one duty cycle (s)
 N_{av} : average speed (r/min)
 N : driving speed (r/min)

If the calculation results for the effective torque and average rotation speed are not within the range of continuous usage in the graph shown in "1-14 Usable range," take measures to reduce the duty.

- Example 3: getting effective torque and average speed

Effective torque and average speed are studied by using the operation conditions of Example 1 and 2.

1) Effective torque

From the parameters of $T_a = 8.3 \text{ Nm}$, $T_r = 0 \text{ N}\cdot\text{m}$, $t_a = 0.113 \text{ s}$, $t_r = t_d = 0.03 \text{ s}$, $t = 0.4 \text{ s}$,

$$T_m = \sqrt{\frac{0.9^2 \times (0.03 + 0.03)}{0.4}} = 0.349 \text{ Nm}$$

The value exceeds the allowable continuous torque (0.29 Nm) of RSF-5B-50 temporarily selected in Example 1, so continuous operation cannot be done using the cycle set in Example 2. The following formula is the formula for effective torque solved for t . By substituting the value of allowable continuous torque in T_m of this formula, the allowable value for one cycle time can be obtained.

$$t = \frac{T_a^2 \times (t_a + t_d) + T_r^2 \times t_r}{T_m^2}$$

Substituting 0.9 Nm for T_a , 0 Nm for T_r , 0.349 Nm for T_m , 0.03 s for t_a , 0.113 s for t_r , and 0.03 s for t_d :

$$t = \frac{0.9^2 \times (0.03 + 0.03)}{0.29^2} = 0.578 \text{ [s]}$$

Namely, when the time for one duty cycle is set more than 0.578 s, the effective torque [T_m] becomes less than 2.9 Nm, and the actuator can drive the load with lower torque than the continuous torque continuously.

2) Average speed

From the parameters of $N = 140 \text{ r/min}$, $t_a = 0.03 \text{ s}$, $t_r = 0.113 \text{ s}$, $t_d = 0.03 \text{ s}$, $t = 0.4 \text{ s}$

$$N_{av} = \frac{140/2 \times 0.03 + 140 \times 0.113 + 140/2 \times 0.03}{0.578} = 34.64 \text{ [r/min]}$$

As the speed is less than the continuous speed (90 r/min) of RSF-5B-50, it is possible to drive it continuously on new duty cycle.

2-4-7 Permissible overloaded time

In case RSF supermini series is intermittently operated in allowable continuous torque or more, the overloaded time is limited by the protective function in the driver even if the duty cycle is allowed. The limits are shown in the figure below.

RSF-3C

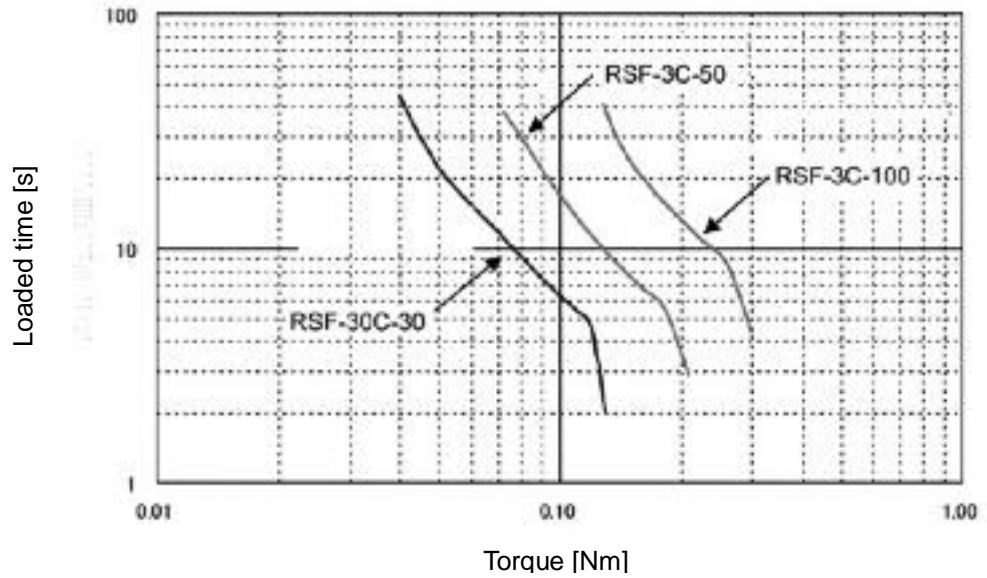

RSF-5B

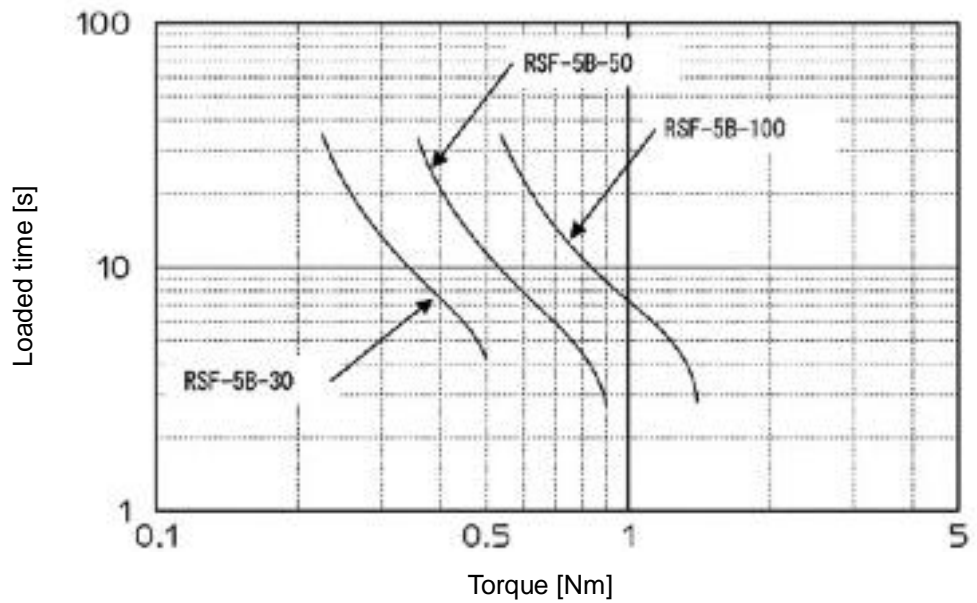

Chapter 3 Installing the actuator

3-1 Receiving Inspection

Check the following when products are received.

- Inspection procedure
- (1) Check the shipping container and item for any damage that may have been caused during transportation. If the item is damaged, immediately report the damage to the dealer it was purchased from.
- (2) A label is attached on the right side of the RSF supermini series actuator. Confirm the products you ordered by comparing with the model on the [TYPE] line of the label. If it is different, immediately contact the dealer it was purchased from.

The model code is interpreted as follows:

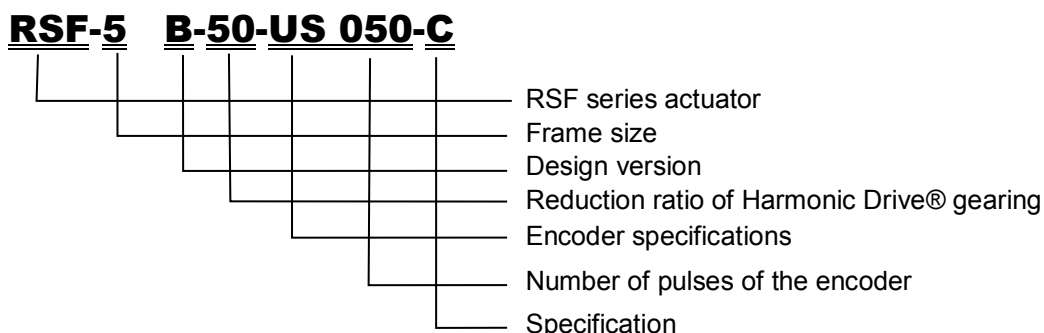

For details of model symbols, refer to “1-2 Models” on page 2.

- (3) On the label of the HA-680 driver, the model code of the actuator to be driven is indicated on the [ADJUSTED FOR USE WITH] line. Match the actuator with its driver so as not to confuse the item with the other actuators.



Only connect the actuator specified on the driver label.

The drivers have been tuned for the actuator specified on the driver label. Wrong combination of drivers and actuators may cause low torque problems or over current that may cause physical injury and fire.

- (4) The driver is for 24VDC supply voltage only. Any power supply voltage other than 24VDC cannot be used.



Do not connect a supply voltage other than the voltage specified on the label.

The wrong power supply voltage (other than 24VDC) may damage the driver resulting physical injury and fire.

3-2 Notice on handling

Handle RSF supermini series actuators with care, specifically:



Do not plug the actuators directly into a commercial line power source.

This could burn out the actuator, potentially resulting in a fire and/or electrical hazard.



- (1) Do not apply impact or unnecessary excessive force to output flange of actuators.
- (2) Do not put actuators on in a location where the driver could easily fall.
- (3) The allowable temperature for storage is from -20°C to $+60^{\circ}\text{C}$. Do not expose it to the sunlight for a long time and do not store it in areas with widely fluctuating temperatures.
- (4) The allowable relative humidity for storage is less than 80%. Do not storage it in highly humid place or in a place where temperature changes excessively during the course of a day.
- (5) Do not store units in locations with corrosive gas or particles.

3-3 Location and installation

3-3-1 Environment of location

The environmental conditions of the location for RSF supermini series actuators must be as follows.

- ◆ Service temperature: 0°C to 40°C
When the actuator is installed in a closed space, the temperature in the space may be higher than the atmosphere because of heat emission by the actuator. Design the closed space size, ventilation system, and device locations so the ambient temperature near the actuator is always less than 40°C.
- ◆ Service humidity: 20 to 80% relative humidity, without condensation
Make sure no water condensation occurs at the place where there is a large temperature change in a day or due to frequent heat-and-cool cycles due to the operation of the actuator.
- ◆ Vibration: less than 49m/sec^2 (10Hz~400Hz)
- ◆ Impact: less than 300 m/sec^2
- ◆ Make sure the actuator is in an area free from: dust, water condensation, metal powder, corrosive gas, water, water drops, and oil mist.
- ◆ Locate the driver indoors. Do not expose it to the sunlight.

3-3-2 Considerations into External Noise

Pay sufficient attention when installing the actuator: The actuator may malfunction by external noise depending on the conditions of installation.

- ◆ Make sure that the FG line of RSF-5B is securely grounded.
- ◆ Because RSF-3C does not have any FG line from the motor enclosure. Thus, when using it, make sure that that enclosure is securely grounded to the body of the equipment through the gear head house. In addition, make sure that the body of the equipment is securely grounded.
- ◆ Do not bind the motor line and encoder signal line together.
- ◆ Do not draw any external power line (i.e., driver power supply line, 100/200 VAC line.), actuator signal line, and motor line through the same pipe or duct or bind them together.

The noise tolerance values of RSF supermini equipment are listed below.

They are guide values from a measurement that were performed using a standard relay cable in a noise test environment while the clamp filter included with the product was installed to the equipment..

Note that the noise tolerance values in your actual environment of use may differ from them.

Model	RSF-3C	RSF-5B
Noise tolerance (encoder signal line)	1.5kV	2.0kV

3-3-3 Installation

Since the RSF supermini series actuator is a high precision servo mechanism, great care is required for proper installation.

Install the actuator taking care not to damage accurately machined surfaces. Do not hit the actuator with a hammer. Take note that actuators provide a glass encoder, which may be damaged by impact.

● Procedure

- (1) Align the axis of rotation of the actuator and the load mechanism precisely.

Note 1: Very careful alignment is required especially when a rigid coupling is applied. Slight differences between centerlines will cause failure of the output shaft of the actuator.

Note 2: When installing the actuator to a coupling, use a plastic hammer to avoid excessive physical shocks.

- (2) Fasten the flange of the actuator with flat washers and high strength bolts. Use a torque wrench when tightening the fasteners.

The recommended tightening torque is shown in the table below:

Model		RSF-3C	RSF-5B
Number of bolts		4	2
Bolt size		M1.6	M2
Installation PCD	mm	15	25
Wrenching torque	N·m	0.26	0.25
	kgf·m	0.03	0.03
Transfer torque	N·m	3.0	2.0
	kgf·m	0.3	0.2

Recommended bolt: JIS B 1176 bolt with hexagonal hole; Strength category: JIS B 1051 12.9 or greater

- (3) For wiring operation, refer to “driver manual or data sheet.”

- (4) Motor cable and encoder cable

Do not pull the cable. Do not hang the actuator with the cable. If you do, the connection part may be damaged. Install the cable with slack not to apply tension to the actuator. Especially, do not use the actuator under any condition where the cable is bent repeatedly.



Do not disassemble and re-assemble the actuator.

The Harmonic Drive Systems, Inc. does not guarantee the actuator that has been reassembled by others than the authorized persons by the Harmonic Drive Systems, Inc.

Chapter 4 Motor shaft retention brake(RSF-5B)

The RSF supermini series provides an actuator with a motor shaft retention brake as standard (Option symbol: B), which can meet the fail-safe requirement without any additional brake.

The brake has 2 coils; one for releasing brake, and another for retaining the released state. By controlling the currents through the coils, power consumption during retention of brake release can be reduced.

4-1 Motor shaft retention brake specifications

Item		Gear ratio			
		30	50	100	
Method		Single disc dry type deenergisation operation type (Separate attraction coil and retention coil)			
Brake operating voltage		V	24VDC±10%		
Current consumption during release (at 20°C)		A	0.8		
Current consumption during retention of release (at 20°C)		A	0.05		
Retention torque	Note 1	N·m	0.18	0.29	0.44
		kgf·cm	1.84	2.96	4.49
Moment of inertia	Note 1	$(GD^2/4)$ kg·cm ²	0.111×10^{-3}	0.309×10^{-3}	1.234×10^{-3}
		(J) kgf·cm·s ²	1.132×10^{-3}	3.151×10^{-3}	12.58×10^{-3}
Weight	Note 2	g	86.0		
Number of allowable brake operations	Note 3		100,000 times		

Note 1: This is a value at the output shaft of the actuator.

Note 2: This is a value for the entire actuator.

Note 3: The motor shaft rotation speed is controlled as shown in the following table.

Gear ratio	Output shaft rotation speed [r/min]	Motor shaft rotation speed [r/min]
1:30	5.0	150
1:50	3.0	
1:100	1.5	

4-2 Controlling the brake power supply

4-2-1 Using a relay cable (Recommended method)

The optional relay cables for brakes (EWA-B××-JST03-TMC) incorporate a circuit that controls the brake current.

You don't have to control the brake current, so it is recommended to use the actuator with a brake in combination with a relay cable for brakes.

If the relay cable for brakes is used, brake can be operated by turning on/off the brake power supply.

The power supply for the brake (that can output 24VDC±10%) shall be provided by the customer. Use a power supply unit that can output the current during release as described in "4-1 Motor shaft retention brake specifications."

The supply duration of the current consumption during release is 0.5sec or less at 24VDC±10%.

4-2-2 Not using a relay cable

If the optional relay cable for brakes (EWA-B××-JST03-TMC) is not used, the customer must control the brake power supply to the brake release coil and release retention coil.

Supply the power upon brake release and during brake release retention, as shown below.

	Lead wire color	Applied voltage
Upon brake release	Gray/Yellow	24VDC±10%
	Blue/Yellow	
During release retention	Gray/Yellow	0VDC
	Blue/Yellow	24VDC±10%
During brake use	Gray/Yellow	0VDC
	Blue/Yellow	

Supply the power to the coils according to the following time chart.

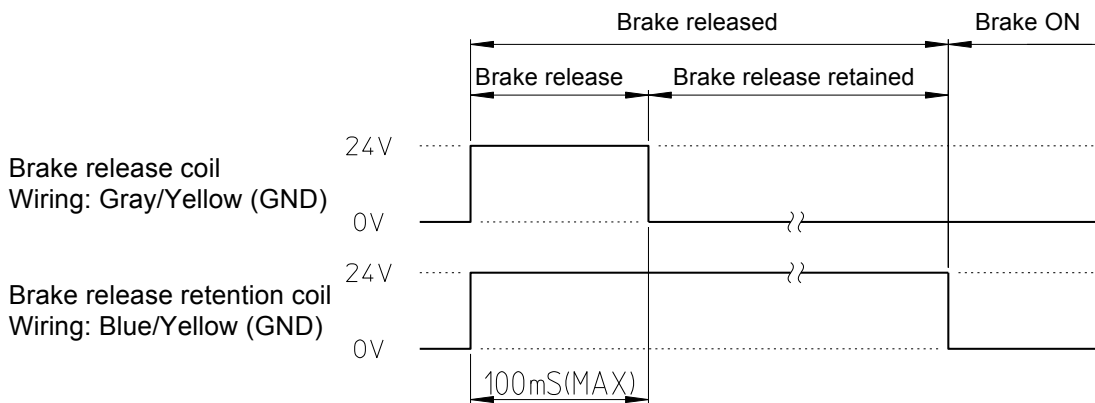

Control the power supply so that the duration in which the power is supplied to the brake release coil (gray/yellow) is 100ms or less. The brake will not be released only by the power supply to the brake release retention coil. To release the brake, also supply the power to the brake release coil.



Warning

The power supply to the brake must be controlled.

Control the power supply to the brake as described in “4-2 Controlling the brake power supply.” If the current flows continuously to the attraction coil, the actuator burns due to temperature rise, causing fire or electric shock.



Warning

Be careful not to exceed the number of allowable brake operations (Refer to “4-1 Motor shaft retention brake specifications”).

If the number is exceeded, the retention torque drops and it cannot be used as a brake.

Chapter 5 Options

5-1 Extension cables

There are extension cables that connect the RSF supermini series actuator and driver.

There are 3 types of extension cables for encoders, motors, and brakes. Select an appropriate type according to the model of the actuator you ordered.

● Extension cable model

HA-680 Driver

(1) For encoders

EWA-E x x -JST09-SP

Cable length (03=3m, 05=5m, 10=10m)

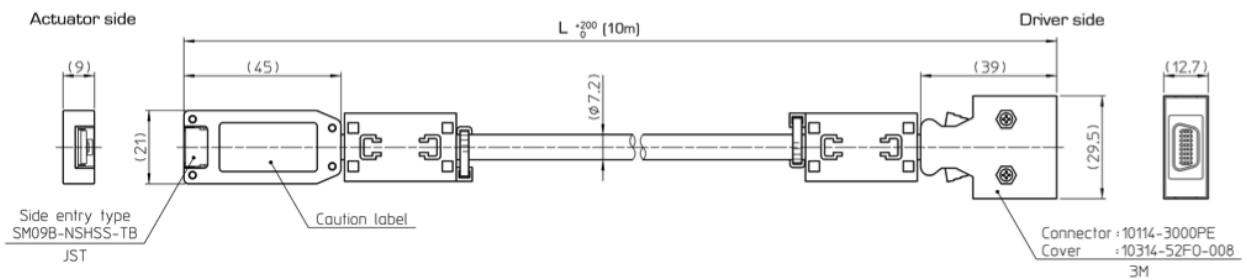

(2) For motors

EWA-M x x -JST04-SP

Cable length (03=3m, 05=5m, 10=10m)

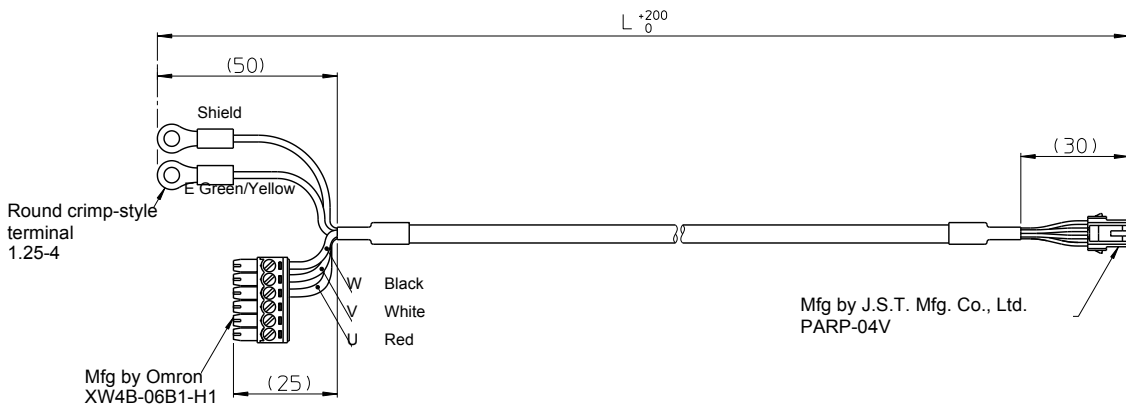

(3) For brakes

EWA-B x x -JST03-TMC

Cable length (03=3m, 05=5m, 10=10m)

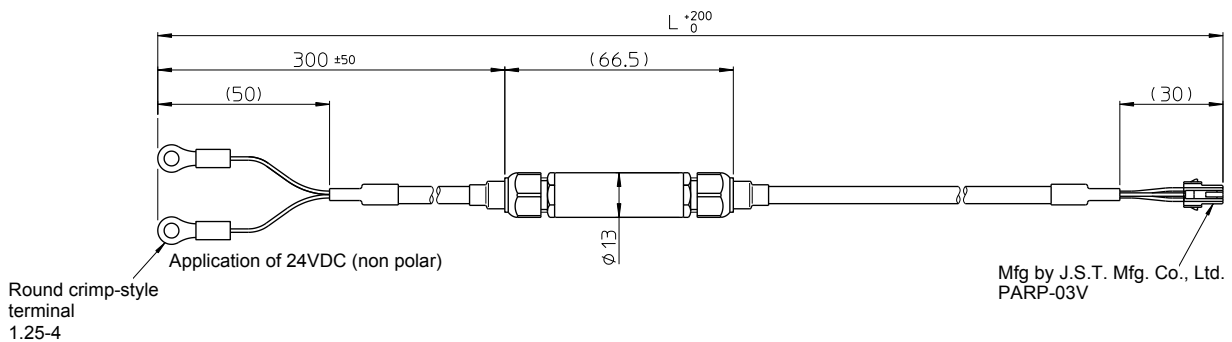

5-1 Extension cables

There are extension cables that connect the RSF supermini series actuator and driver.

There are 3 types of extension cables for encoders, motors, and brakes. Select an appropriate type according to the model of the actuator you ordered.

● Extension cable model

DCJ/DDP/DEP Driver

(1) For encoders

EWA-E x x -JST09-SP

Cable length (03=3m, 05=5m, 10=10m)

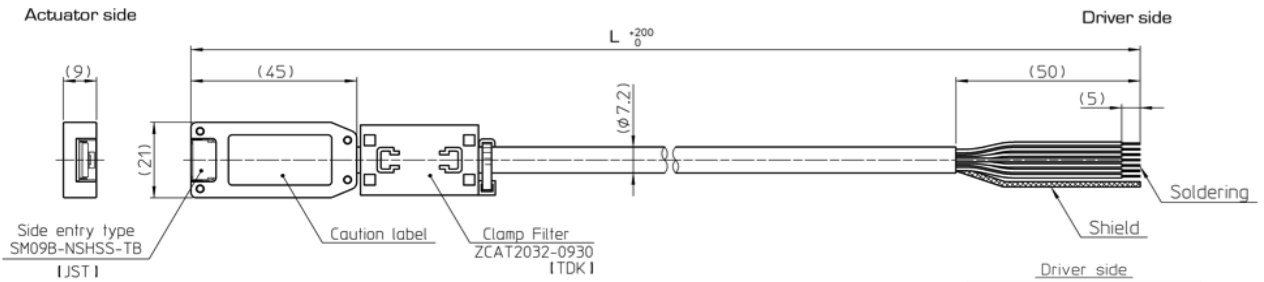

(2) For motors

EWA-M x x -JST04-SP

Cable length (03=3m, 05=5m, 10=10m)

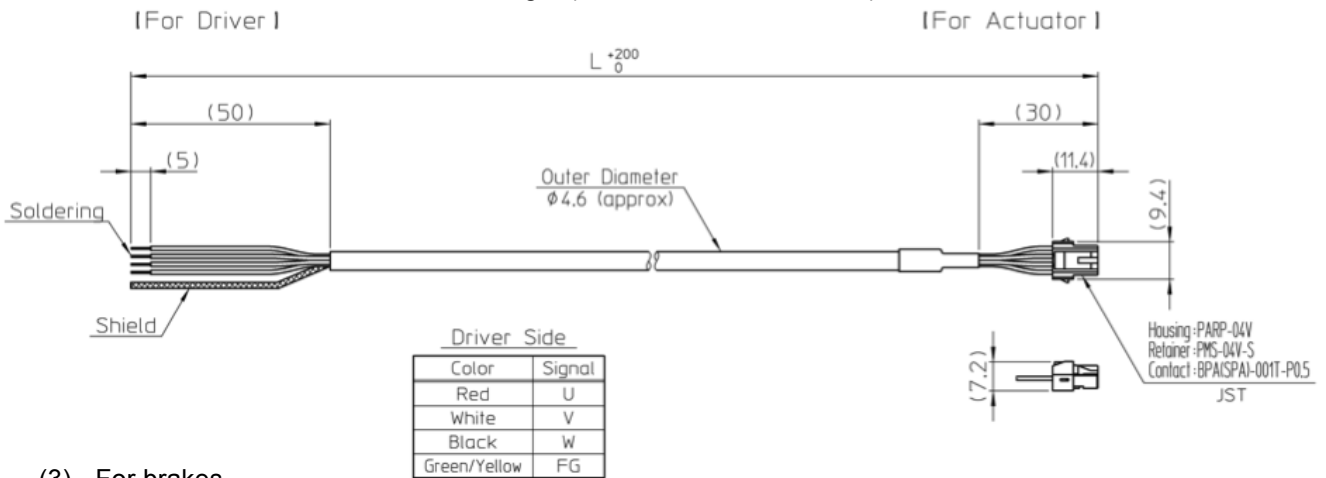

(3) For brakes

EWA-B x x -JST03-TMC

Cable length (03=3m, 05=5m, 10=10m)

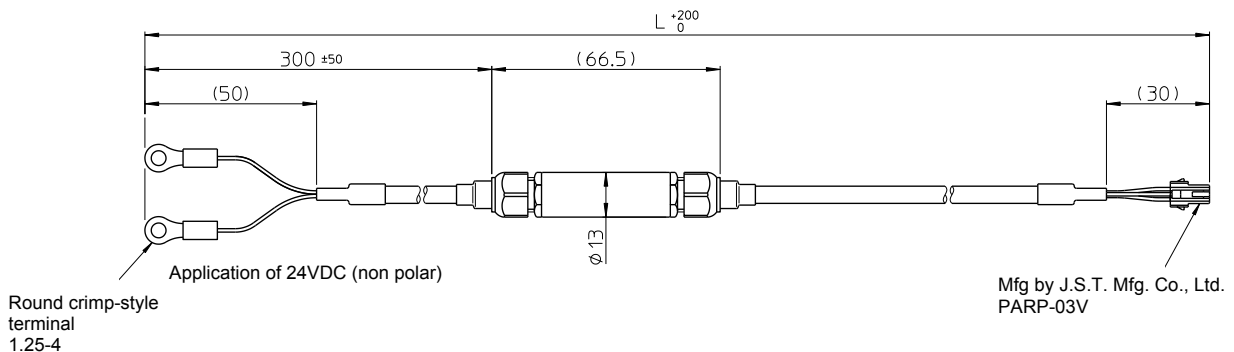

5-3 Connectors

HA-680 Driver

There are 2 types of connectors for the driver for different set types:

- Connector model: CNK-HA68-S1
For CN1, CN2, actuator line connection, power supply connection 4 types
- Connector model: CNK-HA68-S2
For CN2, power supply connection 2 types

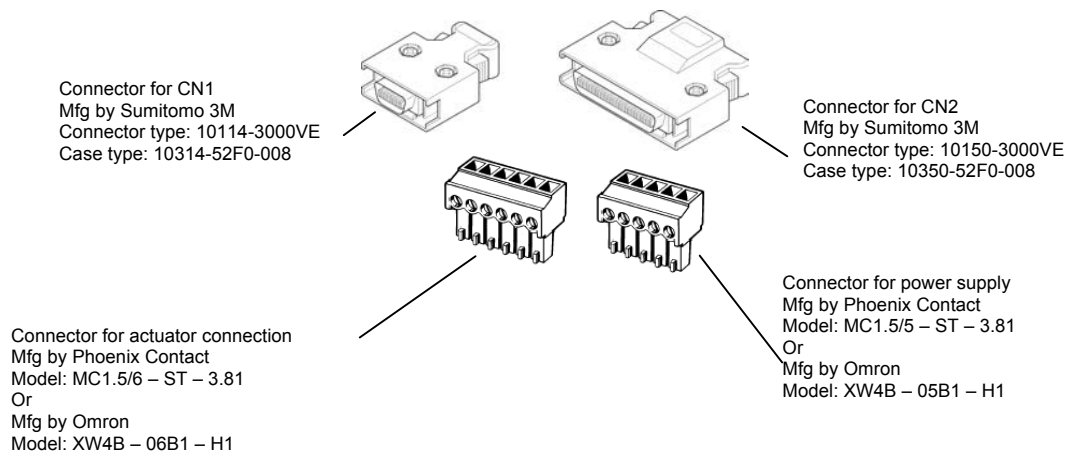

DCJ Series ----- ACJ – CK – Poke/Crimp Connector Kit

DDP Series----- ADP – CK – Solder Cup Connector Kit

DEP Series ----- AEP – CK – Solder Cup Connector Kit

(6) Angle

SI unit	rad		
↓			
Unit	Deg.	Min.	Sec.
Coefficient	57.3	3.44×10^3	2.06×10^5

Unit	Deg.	Min.	Sec.
Coefficient	0.01755	2.93×10^{-4}	4.88×10^{-6}
↓			
SI unit	rad		

(7) Angular speed

SI unit	rad/s			
↓				
Unit	Deg./s	Deg./min	r/s	r/min
Coefficient	57.3	3.44×10^3	0.1592	9.55

Unit	Deg./s	Deg./min	r/s	r/min
Coefficient	0.01755	2.93×10^{-4}	6.28	0.1047
↓				
SI unit	rad/s			

(8) Angular acceleration

SI unit	rad/s ²	
↓		
Unit	Deg./s ²	Deg./min ²
Coefficient	57.3	3.44×10^3

Unit	Deg./s ²	Deg./min ²
Coefficient	0.01755	2.93×10^{-4}
↓		
SI unit	rad/s ²	

(9) Torque

SI unit	Nm			
↓				
Unit	kgfm	lbft	lbin	ozin
Coefficient	0.102	0.738	8.85	141.6

Unit	kgfm	lbft	lbin	ozin
Coefficient	9.81	1.356	0.1130	7.06×10^{-3}
↓				
SI unit	Nm			

(10) Moment of inertia

SI unit	kgm ²							
↓								
Unit	kgfms ²	kgfcms ²	lbft ²	lbfts ²	lbin ²	lbins ²	ozin ²	ozins ²
Coefficient	0.102	10.2	23.73	0.7376	3.42×10^3	8.85	5.47×10^4	141.6
↓								
Unit	kgfms ²	kgfcms ²	lbft ²	lbfts ²	lbin ²	lbins ²	ozin ²	ozins ²
Coefficient	9.81	0.0981	0.0421	1.356	2.93×10^{-4}	0.113	1.829×10^{-5}	7.06×10^{-3}
↓								
SI unit	kgm ²							

(11) Torsional spring constant, moment of rigidity

SI unit	Nm/rad				
↓					
Unit	kgfm/rad	kgfm/arc min	kgfm/Deg.	lbft/Deg.	lbin/Deg.
Coefficient	0.102	2.97×10^{-5}	1.78×10^{-3}	0.0129	0.1546
↓					
Unit	kgfm/rad	Kgfm/arc min	kgfm/Deg.	lbft/Deg.	lbin/Deg.
Coefficient	9.81	3.37×10^4	562	77.6	6.47
↓					
SI unit	Nm/rad				

Appendix 2 Calculations of moment of inertia

1. Calculation formulas for mass and moment of inertia

(1) When center of revolution and line of center of gravity match

Calculation formulas for mass and moment of inertia are shown below.

m: Mass (kg)

I_x, I_y, I_z : moment of inertia (kgm^2) making Axes x, y and z as centers of revolution

G: Distance from edge surface of center of gravity

ρ : Specific gravity

Units - Length: m, mass: kg, moment of inertia: kgm^2

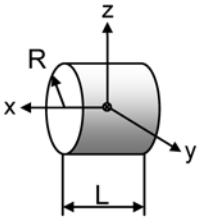
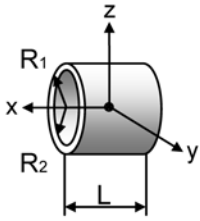
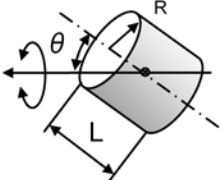
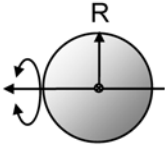
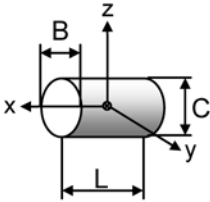
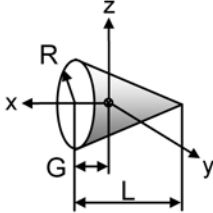
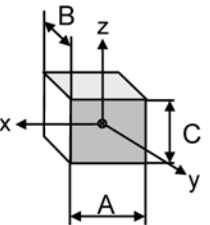
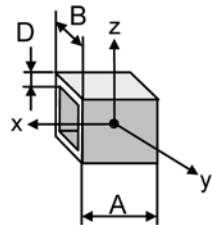
Shape of object	Mass, inertia, position of center of gravity	Shape of object	Mass, inertia, position of center of gravity
	$m = \pi R^2 L \rho$ $I_x = \frac{1}{2} m R^2$ $I_y = \frac{1}{4} m \left(R^2 + \frac{L^2}{3} \right)$ $I_z = \frac{1}{4} m \left(R^2 + \frac{L^2}{3} \right)$	 <p>R1: Outside diameter R2: Inside diameter</p>	$m = \pi (R_1^2 + R_2^2) L \rho$ $I_x = \frac{1}{2} m (R_1^2 + R_2^2)$ $I_y = \frac{1}{4} m \left\{ (R_1^2 + R_2^2) + \frac{L^2}{3} \right\}$ $I_z = \frac{1}{4} m \left\{ (R_1^2 + R_2^2) + \frac{L^2}{3} \right\}$
	$m = \pi R^2 L \rho$ $I_\theta = \frac{1}{12} m \times \left\{ 3R^2(1 + \cos^2\theta) + L^2 \sin^2\theta \right\}$		$m = \frac{4}{3} \pi R^3 \rho$ $I = \frac{2}{5} m R^2$
	$m = \pi B C L \rho$ $I_x = \frac{1}{16} m (B^2 + C^2)$ $I_y = \frac{1}{4} m \left(\frac{C^2}{4} + \frac{L^2}{3} \right)$ $I_z = \frac{1}{4} m \left(\frac{B^2}{4} + \frac{L^2}{3} \right)$		$m = \frac{\pi}{3} \pi R^2 L \rho$ $I_x = \frac{3}{10} m R^2$ $I_y = \frac{3}{80} m (4R^2 + L^2)$ $I_z = \frac{3}{80} m (4R^2 + L^2)$ $G = \frac{L}{4}$
	$m = A B C \rho$ $I_x = \frac{1}{12} m (B^2 + C^2)$ $I_y = \frac{1}{12} m (C^2 + A^2)$ $I_z = \frac{1}{12} m (A^2 + B^2)$		$m = 4AD(B - D)\rho$ $I_x = \frac{1}{3} m (B \cdot D)^2 + D^2$ $I_y = \frac{1}{6} m (A^2 + (B \cdot D)^2 + D^2)$ $I_z = \frac{1}{6} m (A^2 + (B \cdot D)^2 + D^2)$

Appendix 2 Calculations of moment of inertia

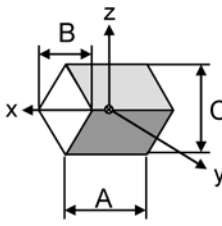
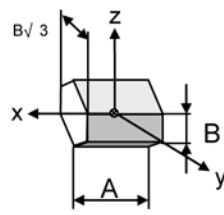
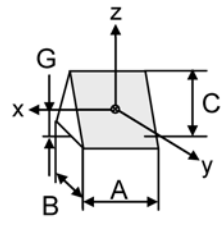
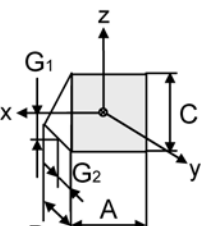
Shape of object	Mass, inertia, position of center of gravity	Shape of object	Mass, inertia, position of center of gravity
Rhombic prism 	$m = \frac{1}{2} ABC \rho$ $I_x = \frac{1}{24} m (B^2 + C^2)$ $I_y = \frac{1}{24} m (C^2 + 2A^2)$ $I_z = \frac{1}{24} m B^2 + 2A^2$	Regular hexagon prism 	$m = \frac{3\sqrt{3}}{2} AB^2 \rho$ $I_x = \frac{5}{12} m B^2$ $I_y = \frac{1}{12} m \left(A^2 + \frac{5}{2} B^2 \right)$ $I_z = \frac{1}{12} m \left(A^2 + \frac{5}{2} B^2 \right)$
Equilateral triangular prism 	$m = \frac{1}{2} ABC \rho$ $I_x = \frac{1}{12} m \left(\frac{B^2}{2} + \frac{2}{3} C^2 \right)$ $I_y = \frac{1}{12} m \left(A^2 + \frac{2}{3} C^2 \right)$ $I_z = \frac{1}{12} m \left(A^2 + \frac{B^2}{2} \right)$ $G = \frac{C}{3}$	Right-angled triangular prism 	$m = \frac{1}{2} ABC \rho$ $I_x = \frac{1}{36} m (B^2 + C^2)$ $I_y = \frac{1}{12} m \left(A^2 + \frac{2}{3} C^2 \right)$ $I_z = \frac{1}{12} m \left(A^2 + \frac{2}{3} B^2 \right)$ $G_1 = \frac{C}{3} \quad G_2 = \frac{B}{3}$

◆ Example of specific gravity

The following table shows informative values of specific gravity. Please check actual specific gravities of materials individually.

Material	Specific gravity	Material	Specific gravity	Material	Specific gravity
SS45C	7.86	Brass	8.5	Epoxy resin	1.9
SS41C	7.85	Aluminum	2.7	ABS	1.1
Cast steel	7.85	Duralumin	2.8	Silicone resin	1.8
Cast iron	7.19	Teflon	2.2	Urethane rubber	1.25
Copper	8.92	Fluorine resin	2.2	Chloroprene rubber	1.15

(2) When center of revolution and line of center of gravity do not match

Moment of inertia when axis of center of gravity and axis of revolution of an inertia field do not match is calculated by the following formula.

$$I = I_g + mF^2$$

I: Moment of inertia when axis of center of gravity and axis of revolution do not match (kgm²)

I_g: Moment of inertia when axis of center of gravity and axis of revolution match (kgm²)

Calculated by formula shown in (1) in accordance with shape.

m: Mass (kg)

F: Distance between axis of revolution and axis of center of gravity (m)

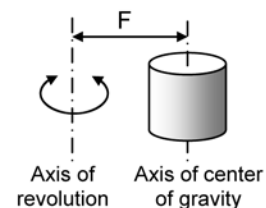

(3) Moment of inertia of linear motion object

The moment of inertia converted into an RSF-supermini actuator axis of a linear motion object driven by a screw is calculated by the following formula.

$$I = m \left(\frac{P}{2\pi} \right)^2$$

I: Moment of inertia converted into actuator axis of a linear motion object (kgm²)

m: Mass (kg)

P: Amount of linear movement per revolution of actuator (m/rev)

2. Moment of inertia of circular cylinder

Approximate values of moment of inertia of circular cylinder can be calculated from the graph on the right.

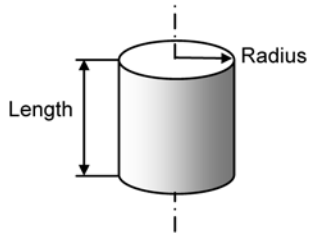

The top graph is applied to aluminum (specific gravity 2.7) and the bottom graph, to steel (specific gravity 7.85).

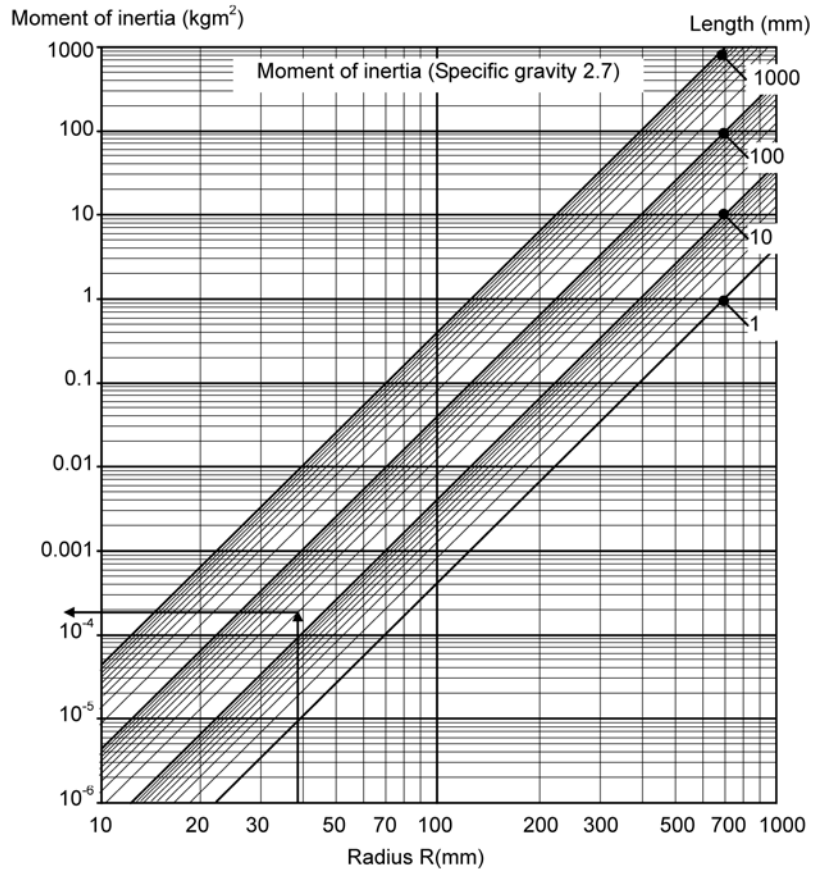

(Example)

Material: Aluminum
 Outside diameter: 100mm
 Length: 7mm
 Shape: Circular cylinder
 Outside diameter: 100mm

Since the outside diameter is 100mm, the radius is 50mm.
 Based on the top graph, moment of inertia is about $1.9 \times 10^{-4} \text{ kgm}^2$.

(Calculated value: 0.000186 kgm^2)

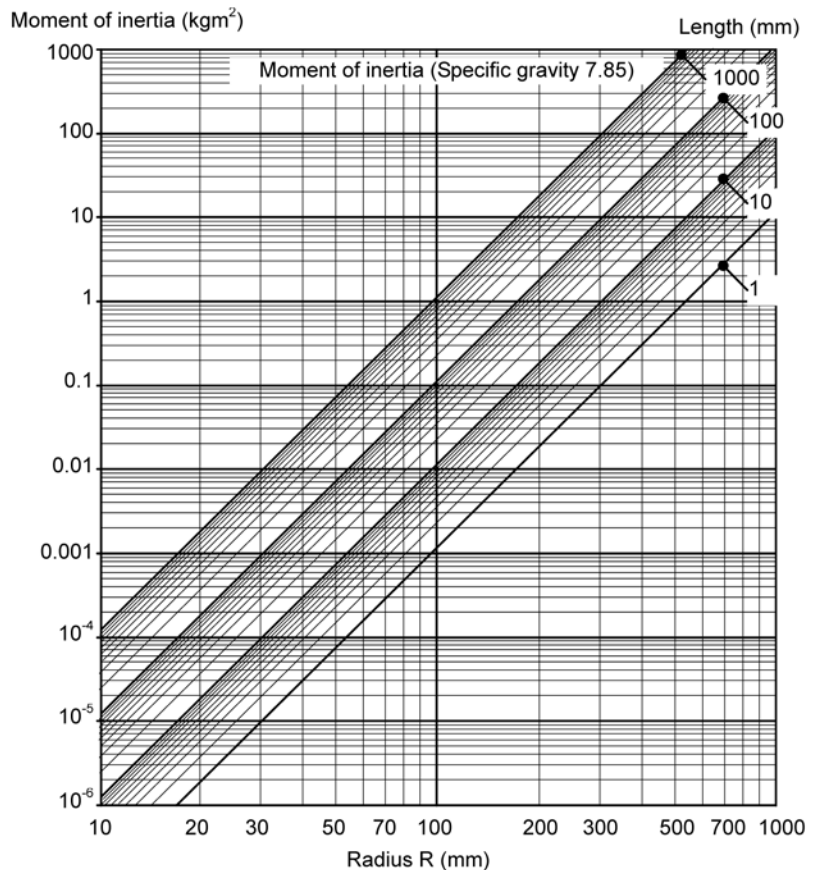

Warranty Period and Terms

The RSF supermini series actuators are warranted as follows:

■ Warranty period

Under the condition that the actuator are handled, used and maintained properly followed each item of the documents and the manuals, all the RSF supermini series actuators are warranted against defects in workmanship and materials for the shorter period of either one year after delivery or 2,000 hours of operation time.

■ Warranty terms

All the RSF supermini series actuators are warranted against defects in workmanship and materials for the warranted period. This limited warranty does not apply to any product that has been subject to:

- (1) user's misapplication, improper installation, inadequate maintenance, or misuse.
- (2) disassembling, modification or repair by others than Harmonic Drive Systems, Inc.
- (3) imperfection caused by the other than the RSF supermini series actuator and the HA-680 servo driver.
- (4) disaster or others that does not belong to the responsibility of Harmonic Drive Systems, Inc.

Our liability shall be limited exclusively to repairing or replacing the product only found by Harmonic Drive Systems, Inc. to be defective. Harmonic Drive Systems, Inc. shall not be liable for consequential damages of other equipment caused by the defective products, and shall not be liable for the incidental and consequential expenses and the labor costs for detaching and installing to the driven equipment.

All efforts have been made to ensure that the information in this catalog is complete and accurate. However, Harmonic Drive LLC is not liable for any errors, omissions or inaccuracies in the reported data. Harmonic Drive LLC reserves the right to change the product specifications, for any reason, without prior notice.

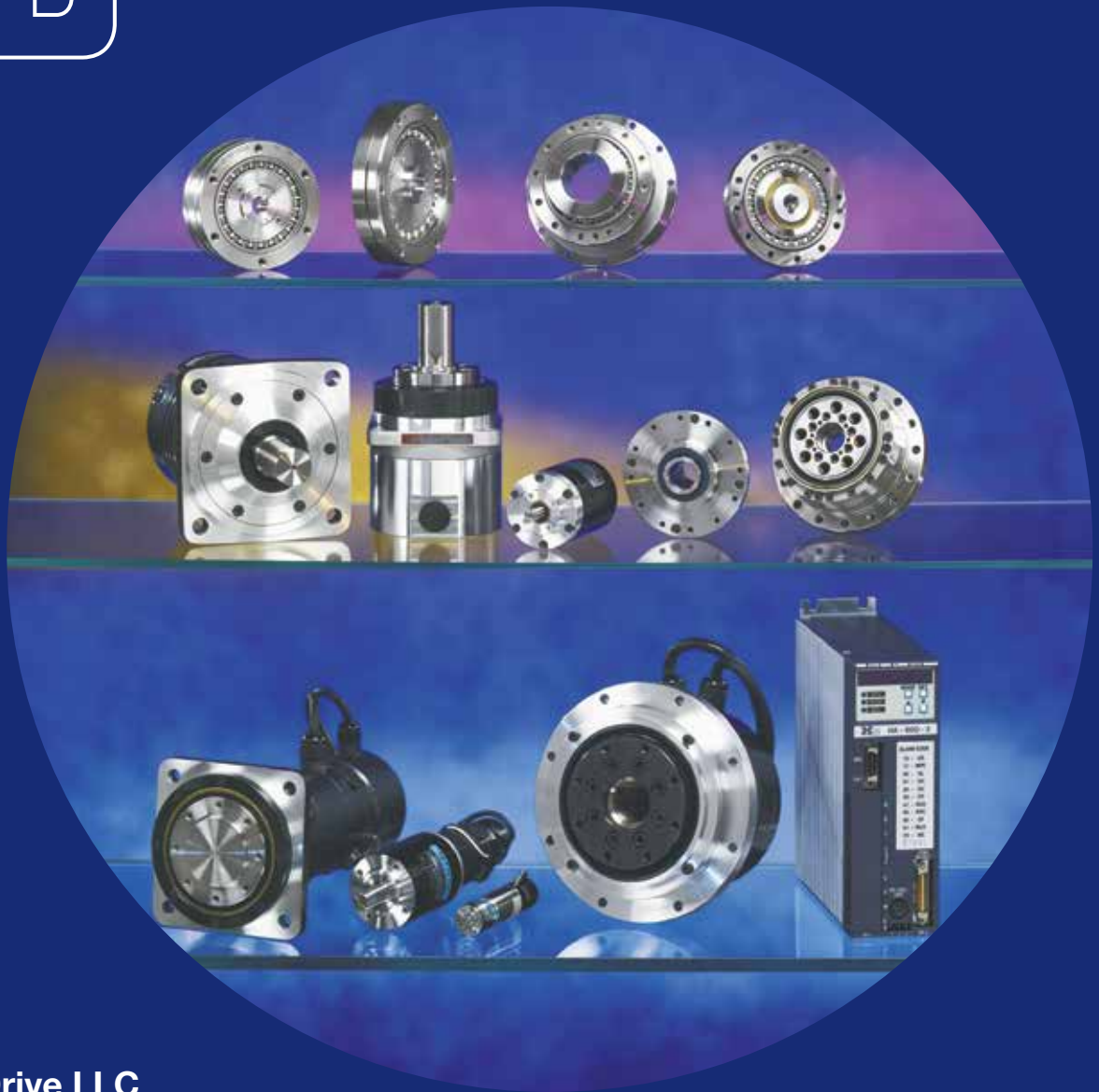

Harmonic Drive LLC

Boston US Headquarters

247 Lynnfield Street
Peabody, MA 01960

New York Sales Office

100 Motor Parkway
Suite 116
Hauppauge, NY 11788

California Sales Office

333 W. San Carlos Street
Suite 1070
San Jose, CA 95110

Chicago Sales Office

137 N. Oak Park Ave., Suite 410
Oak Park, IL 60301

T: 800.921.3332

T: 978.532.1800

F: 978.532.9406

www.HarmonicDrive.net

Group Companies

Harmonic Drive Systems, Inc.
6-25-3 Minami-Ohi, Shinagawa-ku
Tokyo 141-0013, Japan

Harmonic Drive AG
Hoenbergstrasse, 14, D-6555
Limburg/Lahn Germany

