

SHF and SHG
Component Sets
Housed Units

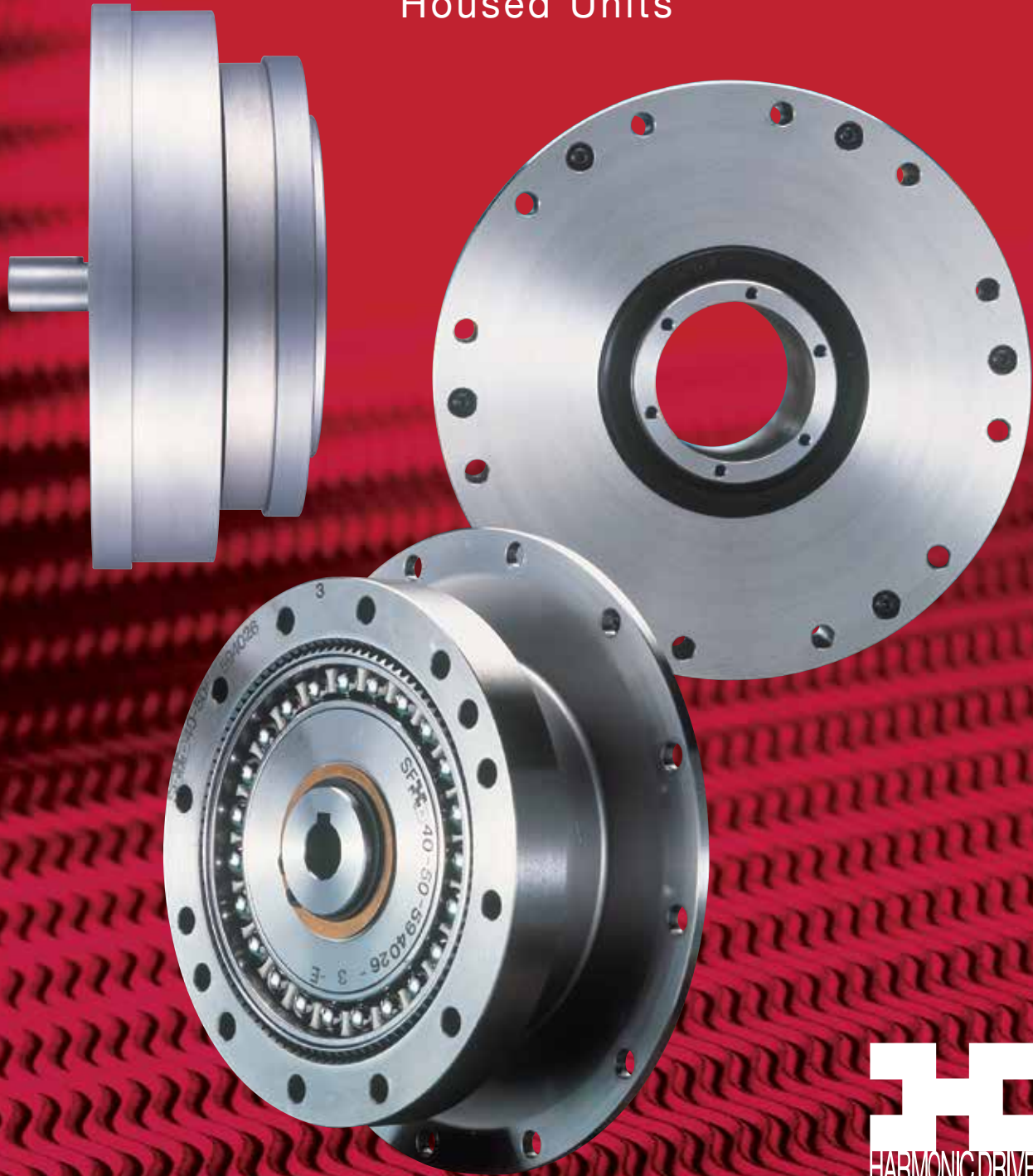

Harmonic Drive® gear
Precision Gearing and Motion Control

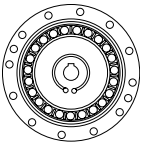

SHF AND SHG HOUSED UNIT

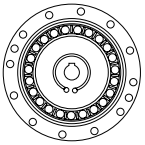

SHF-SHG Series

ABOUT SHF-SHG SERIES

Ordering Information	4
Operating Principle	5
Driving Configurations	6
Application Examples	7
SHG Series Rating Table	10
SHF Series Rating Table	11
Technical Terms, Strength & Life	12
Ratcheting Torque, Buckling Torque	13
Selection Procedure	14
Selection Example	14

COMPONENT TYPE

External Dimensions & Shape	16
Lubrication	18
Recommended Tolerances for Assembly	23
Diameter	24
Assembly of the Flexspline	25
Installation Procedure	26
Assembly Procedure	27

UNIT TYPE

External Dimensions of Housed Unit	28
Specifications for Cross Roller Bearing	34
Output Bearing Rating	35
Output Bearing Life	36
Recommended Tolerances for Assembly	37
Lubrication	39
Hollow Shaft Type	40
Input Shaft Type	41

ENGINEERING DATA

Efficiency of Component Set	42
Efficiency of Housed Unit	45
No Load Running Torque	47
Starting Torque and Backdriving Torque	53
Positioning Accuracy	54
Torsional Stiffness	55
Hysteresis Loss	57
Backlash from Oldham Coupling	57

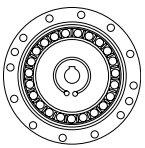

ABOUT SHF-SHG SERIES GEARS

SHG — 25 — 100 — 2UH — SP

ORDERING CODE

NAME OF MODEL	SIZE	RATIO	VERSION	OPTION
SHF: Silk Hat Type (SHF series is available in sizes 11-58) SHG: High-torque Type (SHG series is available in sizes 14-65)	11	50, 100	2A-GR:Component Set 2UH:Unit with hollow input shaft and integrated output bearing. 2UJ:Unit with solid input shaft and integrated output bearing 2S0:Simple Unit: Flat type 2SH:Simple Unit Flat Hollow Shaft type	Our application engineers will be pleased to assist you with special options and their ordering code
	14	30,50,80,100,		
	17	30,50,80,100,120		
	20	30,50,80,100,120,160		
	25	30,50,80,100,120,160		
	32	30,50,80,100,120,160		
	40	50,80,100,120,160		
	45	50,80,100,120,160		
	50	50,80,100,120,160		
58	50,80,100,120,160			
65	80,100,120,160			

Harmonic Drive® Gear Revolution

Harmonic Drive® precision gear continues to evolve by improving performance and functionality.

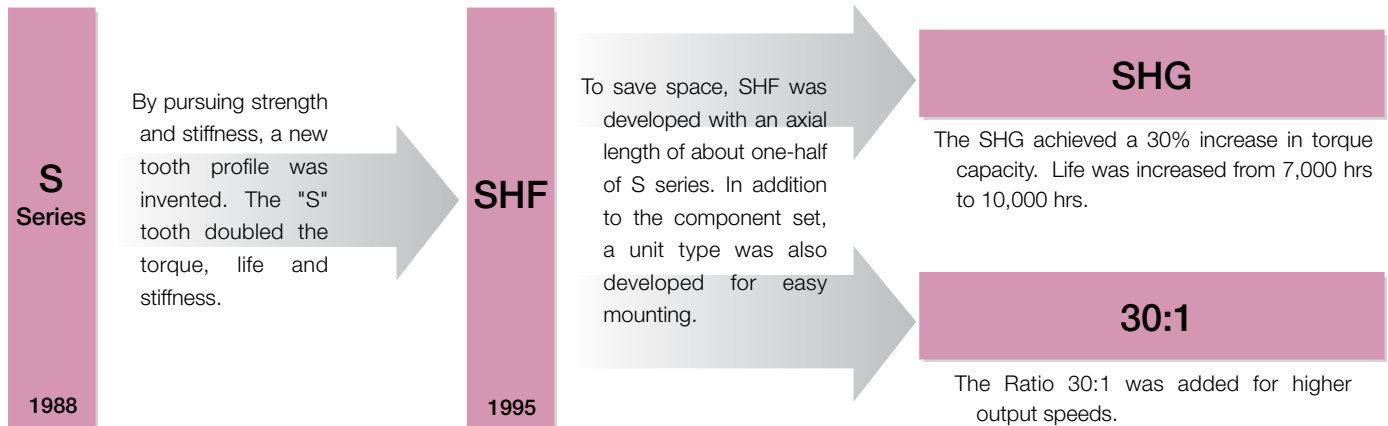

Tooth Profiles

The Harmonic Drive® SHF/SHG component sets and housed units presented in this catalog incorporate the "S" gear tooth profile. This patented tooth profile provides a significant improvement in gear operating characteristics and performance.

The new "S" tooth profile significantly increases the region of tooth engagement. For the traditional tooth profile 15% of the total number of teeth are in contact, while for the new profile up to 30% of the teeth are in contact. The increased number of teeth in engagement results in a 100% increase in torsional stiffness in the low & mid torque ranges.

The new tooth profile also features an enlarged tooth root radius, which results in a higher allowable stress and a corresponding increase in torque capacity. Furthermore, the enlarged region of tooth engagement leads to a more even loading of the Wave Generator bearing, resulting in more than double the life expectancy for the gear.

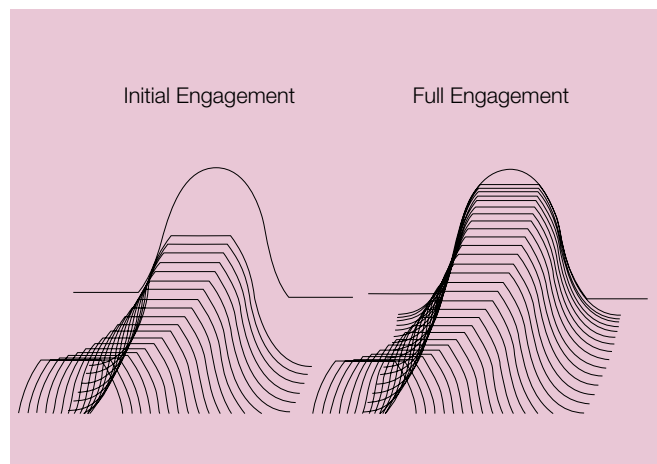

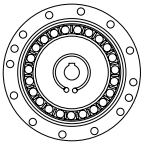

PRINCIPLE AND STRUCTURE

Operating Principle

The FLEXSPLINE is a non-rigid, thin cylindrical steel cup with external teeth on a slightly smaller pitch diameter than the Circular Spline. It fits over and is held in an elliptical shape by the Wave Generator.

The WAVE GENERATOR is a thin raced ball bearing fitted onto an elliptical plug serving as a high efficiency torque converter.

The CIRCULAR SPLINE is a rigid ring with internal teeth, engaging the teeth of the Flexspline across the major axis of the Wave Generator.

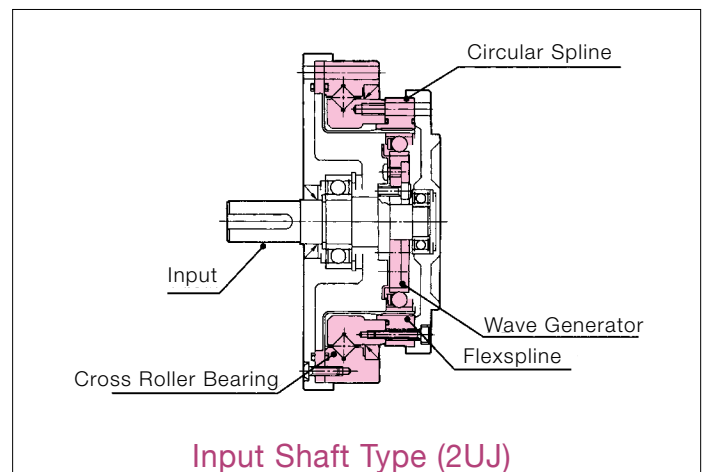
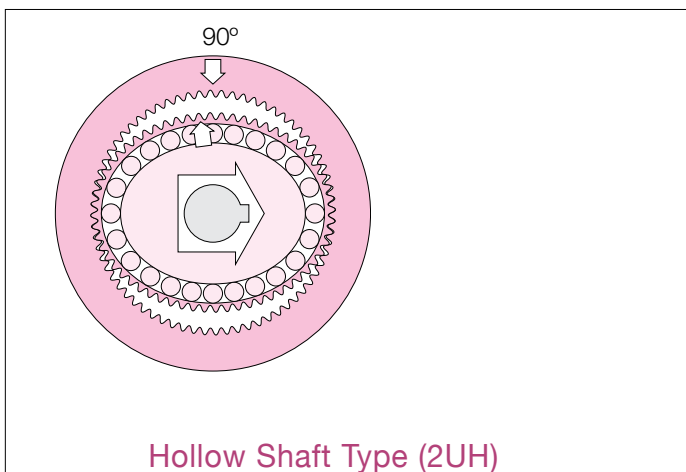
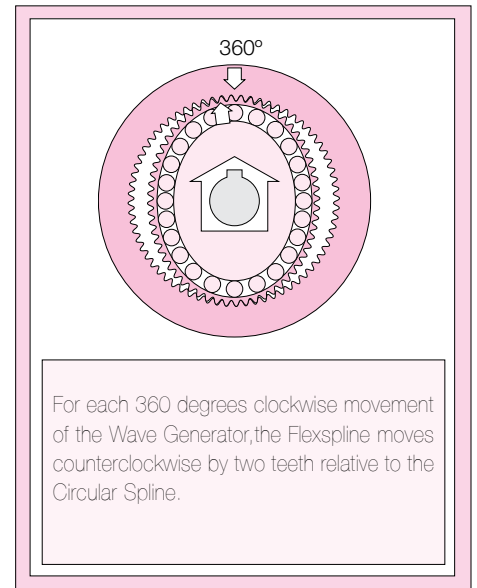
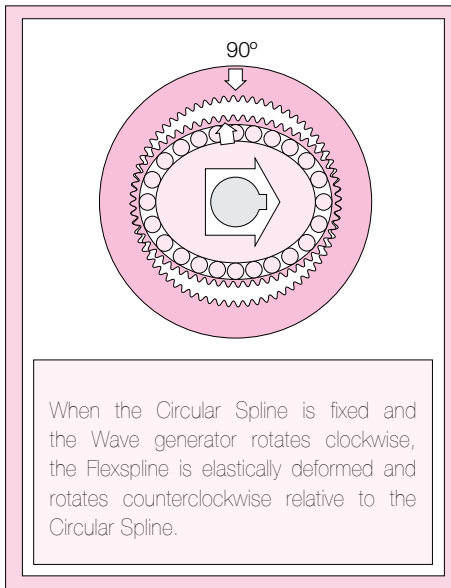
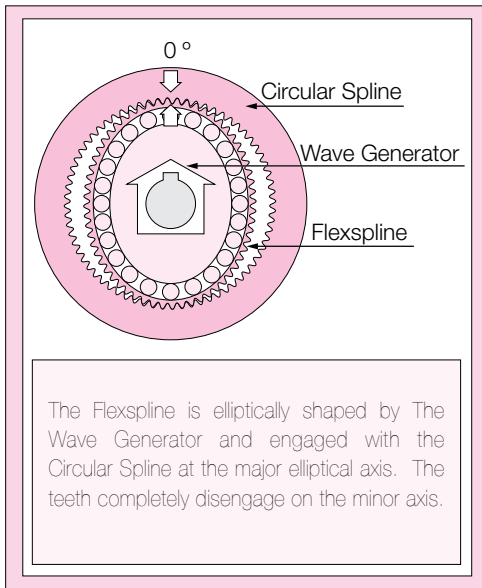
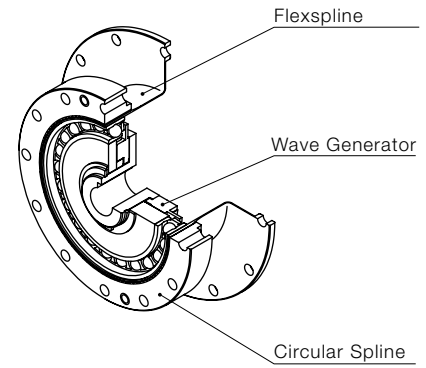

The SHF gear housed unit offers the design engineer convenience and simplicity. The gears are contained within a compact housing, where the output flange is supported by a large diameter cross roller bearing. This provides exceptional moment stiffness with high radial and axial load capacity.

The SHF-2UJ housed units have a different design for the input. This series is driven via a solid shaft. These units, like the SHF-2UH models, integrate high capacity cross roller output bearing to provide a high permissible tilting moment as well as high tilting stiffness.

Simplicity Unit Type *(Option not shown)*

Flat type (2 SO) and Hollow Shaft type (2 SH) have been simplified by eliminating Input and Output Flanges to achieve design flexibility and cost reduction.

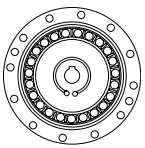

DRIVING CONFIGURATIONS

A variety of different driving configurations are possible, as shown below.

The reduction ratio given in the tables on page 10 and 11 correspond to arrangement 1, in which the Wave Generator acts as the input element, the Circular Spline is fixed and the Flexspline acts as the output element.

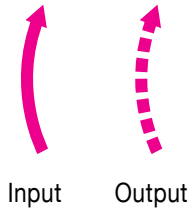

$$\text{Gear Ratio} = \frac{\text{input speed}}{\text{output speed}}$$

1

1. Reduction Gearing
 CS Fixed
 WG Input
 FS Output

Ratio = $\frac{R}{-1}$ [Equation 1]

Input and output in opposite direction.

2

2. Reduction Gearing
 CS Output
 WG Input
 FS Fixed

Ratio = $\frac{R+1}{1}$ [Equation 2]

Input and output in same direction.

3

3. Reduction Gearing
 CS Output
 WG Fixed
 FS Input

Ratio = $\frac{R+1}{R}$ [Equation 3]

Input and output in opposite direction.

4

4. Speed Increaser Gearing
 CS Input
 WG Fixed
 FS Output

Ratio = $\frac{R}{R+1}$ [Equation 4]

Input and output in opposite direction.

5

5. Speed Increaser Gearing
 CS Fixed
 WG Output
 FS Input

Ratio = $\frac{-R}{1}$ [Equation 5]

Input and output in opposite direction.

6

6. Speed Increaser Gearing
 CS Input
 WG Output
 FS Output

Ratio = $\frac{R+1}{-1}$ [Equation 6]

Input and output in opposite direction.

7

7. Differential Gearing
 WG Control Input
 CS Main Drive-Input
 FS Main Drive-Output

Numerous differential functions can be obtained by combinations of the speed and rotational direction of the three basic elements.

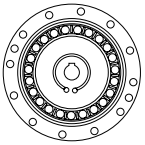

SHF Series Application Examples

Apply SHF-2UH & SHF-2UJ to SCARA robot

The robot arm (Fig. 1) is equipped with SHF-2UH and SHF-2UJ Series units. The hollow shaft of the first axis unit is used to pilot the shaft driving the second axis unit. This allows both motors to be mounted in the base of the robot, minimizing the moment of inertia of the arm.

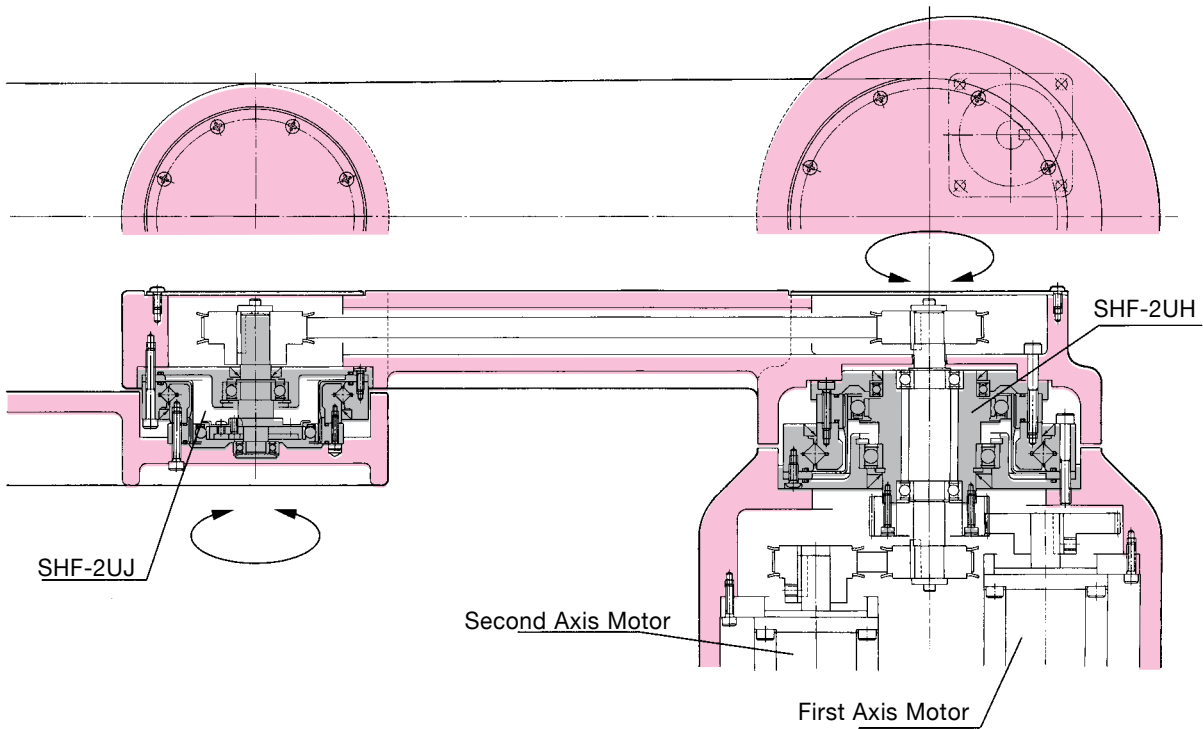

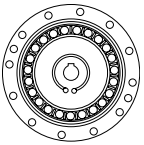

SHF Series Application Examples

Apply SHF-2UH & SHF-2UJ to Gantry robot

This robot hand axis design (Fig.2) incorporates both SHF-2UH and SHF-2UJ units. The second axis is driven through the hollow shaft of the first axis gear. This design has number of advantages, including the compact design and low inertia for the second axis.

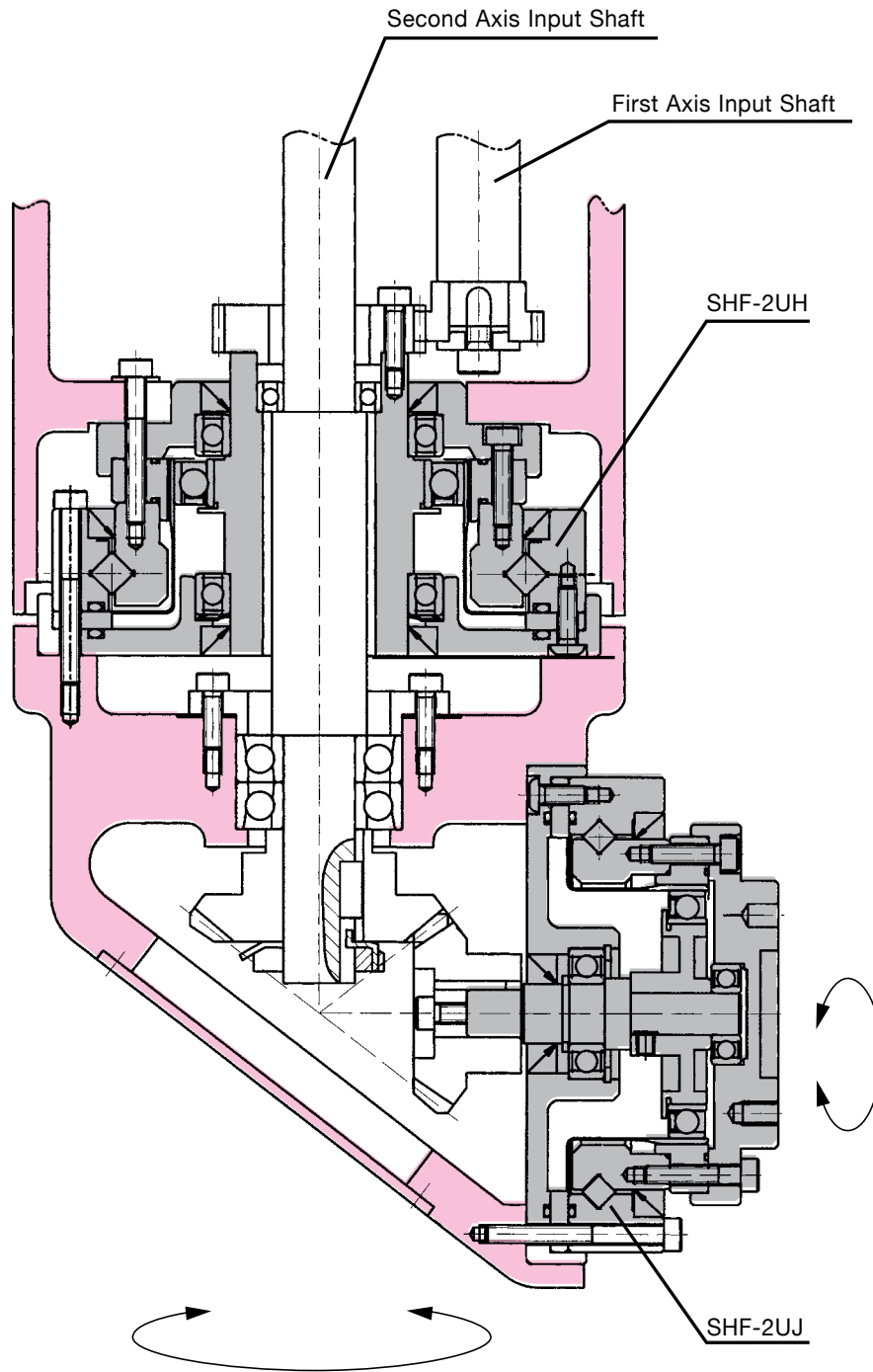

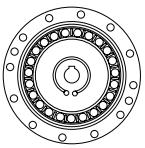

SHF Series Application Examples

Apply SHF-2SO to SCARA robot

Specially designed units are used in the robot arm featured in Fig.3.

The Simplicity units feature SHF-2SO component sets combined with integral cross roller bearing, Circular Spline and Flexspline.

It is important to note that the motor can be assembling from both sides of the unit.

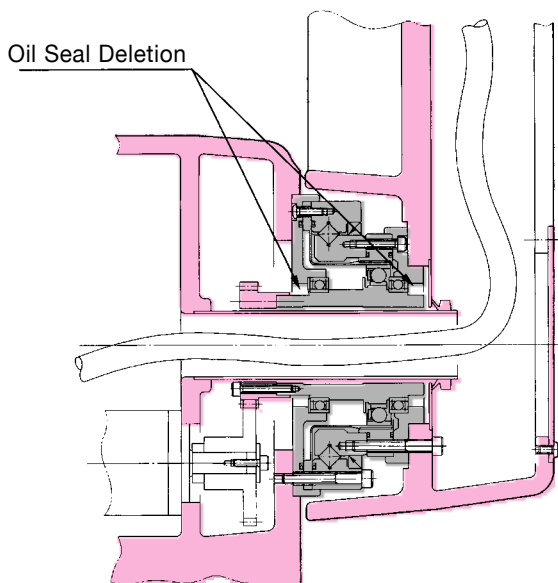
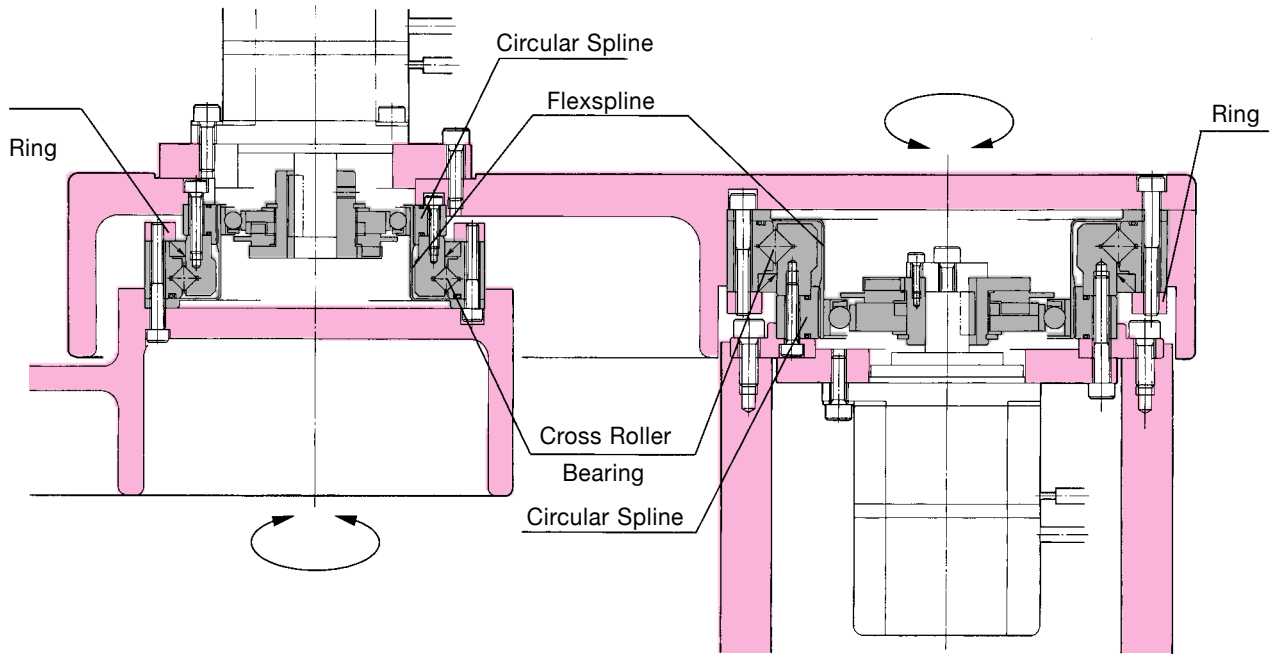

Removal of the rotary shaft seal of SHF-2UH

The friction of the rotary shaft seals at the input side can result in an increased temperature of the SHF-2UH unit during operation. This application example (Fig.4) shows the removal of the (fast running) rotary shaft seals at the input side. The removal of one or both rotary shaft seals at the input element should only be carried out if other measures have been undertaken to prevent the leakage of grease or oil, or if a leakage can be ruled out due to the installation position.

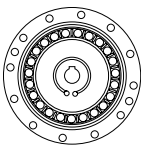

SHG SERIES RATING TABLE

Table 1

Size	Ratio	Rated Torque at 2000 T_r rpm		Limit for Repeated Peak Torque		Limit for Average Torque		Limit for Momentary Peak Torque		Maximum Input Speed		Limit for Average Input Speed		Moment of Inertia*1	
		Nm	in-lb	Nm	in-lb	Nm	in-lb	Nm	in-lb	Oil	Grease	Oil	Grease	$10^{-4} \text{kg}\cdot\text{m}^2$	$10^{-5} \text{kg}\cdot\text{m}^2$
		rpm		rpm		rpm		rpm		rpm		rpm		rpm	
14	50	7	62	23	204	9	80	46	407	14,000	8,500	6,500	3,500	0.033	0.034
	80	10	89	30	266	14	124	61	540					(0.091)	(0.093)
	100	10	89	36	319	14	124	70	620					(0.025)	(0.026)
17	50	21	186	44	389	34	301	91	805	10,000	7,300	6,500	3,500	0.079	0.081
	80	29	257	56	496	35	310	113	1000					(0.193)	(0.197)
	100	31	274	70	620	51	451	143	1266					(0.059)	(0.060)
20	120	31	274	70	620	51	451	112	991	10,000	6,500	6,500	3,500	0.193	0.197
	50	33	292	73	646	44	389	127	1124					(0.404)	(0.412)
	80	44	389	96	850	61	540	165	1460					(0.137)	(0.140)
	100	52	460	107	947	64	566	191	1690						
	120	52	460	113	1000	64	566	191	1690						
25	160	52	460	120	1062	64	566	191	1690	7,500	5,600	5,600	3,500	0.413	0.421
	50	51	451	127	1124	72	637	242	2142					(1.070)	(1.090)
	80	82	726	178	1575	113	1000	332	2938					(0.320)	(0.327)
	100	87	770	204	1805	140	1239	369	3266						
	120	87	770	217	1920	140	1239	395	3496						
32	160	87	770	229	2027	140	1239	408	3611	7,000	4,800	4,600	3,500	1.69	1.72
	50	99	876	281	2487	140	1239	497	4398					(2.85)	(2.91)
	80	153	1354	395	3496	217	1920	738	6531					(1.20)	(1.22)
	100	178	1575	433	3832	281	2487	841	7443						
	120	178	1575	459	4062	281	2487	892	7894						
40	160	178	1575	484	4283	281	2487	892	7894	5,600	4,000	3,600	3,000	4.50	4.59
	50	178	1575	523	4629	255	2257	892	7894					(9.28)	(9.47)
	80	268	2372	675	5974	369	3266	1270	11240					(3.41)	(3.48)
	100	345	3053	738	6531	484	4283	1400	12390						
	120	382	3381	802	7098	586	5186	1530	13541						
45	160	382	3381	841	7443	586	5186	1530	13541	5,000	3,800	3,300	3,000	8.68	8.86
	50	229	2027	650	5753	345	3053	1235	10930					(13.8)	(14.1)
	80	407	3602	918	8124	507	4487	1651	15611					(5.80)	(5.92)
	100	459	4062	982	8691	650	5753	2041	18063						
	120	523	4629	1070	9470	806	7133	2288	20249						
50	160	523	4629	1147	10151	819	7248	2483	21975	4,500	3,500	3,000	2,500	12.5	12.8
	80	484	4283	1223	10824	675	5974	2418	21399					(25.2)	(25.7)
	100	611	5407	1274	11275	866	7664	2678	23700					(9.95)	(10.2)
	120	688	6089	1404	12425	1057	9354	2678	23700						
58	160	688	6089	1534	13576	1096	9700	3185	28187	4,000	3,000	2,700	2,200	27.3	27.9
	80	714	6319	1924	17027	1001	8859	3185	28187					(49.5)	(50.5)
	100	905	8009	2067	18293	1378	12195	4134	36586					(20.5)	(20.9)
	120	969	8576	2236	19789	1547	13691	4329	38312						
65	160	969	8576	2392	21169	1573	13921	4459	39462	3,500	2,800	2,400	1,900	46.5	47.8
	80	969	8576	2743	24276	1352	11965	4836	42799					(94.1)	(96.0)
	100	1236	10939	2990	26462	1976	17488	6175	54649					(35.5)	(36.2)
	120	1236	10939	3263	28878	2041	18063	6175	54649						
160	1236	10939	3419	30258	2041	18063	6175	54649							

Note: *1 The moment of inertia : $I = 1/4 GD^2$, reflected to input side (wave generator).
 Row indicates unit type.
 Top: Component Type
 Middle: (Hollow Type 2UH)
 Bottom: (Shaft Type 2UJ)

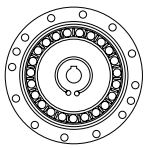

SHF SERIES RATING TABLE

Table 2

Size	Ratio	Rated Torque at 2000 T _r rpm		Limit for Repeated Peak Torque		Limit for Average Torque		Limit for Momentary Peak Torque		Maximum Input Speed		Limit for Average Input Speed		Moment of Inertia ^{*2}	
		Nm	in-lb	Nm	in-lb	Nm	in-lb	Nm	in-lb	Oil rpm	Grease rpm	Oil rpm	Grease rpm	I 10 ⁻⁴ kg·m ²	J 10 ⁻⁵ kgf·m ²
11	50	3.5	31	8.3	73	5.5	49	17	150	8500		3500		0.008	0.082
	100	5	44	11	97	8.9	79	25	221	8500		3500		0.008	0.082
14	30	4	35	9	80	6.8	60	17	150					0.033	0.034
	50	5.4	48	18	159	6.9	61	35	310	14,000	8,500	6,500	3,500	(0.091)	(0.093)
	80	7.8	69	23	204	11	97	47	416					(0.025)	(0.026)
17	100	7.8	69	28	248	11	97	54	478						
	30	8.8	78	16	142	12	106	30	266						
	50	16	142	34	301	26	230	70	620					0.079	0.081
	80	22	195	43	381	27	239	87	770	10,000	7,300	6,500	3,500	(0.193)	(0.197)
	100	24	212	54	478	39	345	110	974					(0.059)	(0.060)
20	120	24	212	54	478	39	345	86	761						
	30	15	133	27	239	20	177	50	443						
	50	25	221	56	469	34	301	98	867					0.193	0.197
	80	34	301	74	655	47	416	127	1124					(0.404)	(0.412)
	100	40	354	82	726	49	434	147	1301	10,000	6,500	6,500	3,500	(0.137)	(0.140)
	120	40	354	87	770	49	434	147	1301						
25	160	40	354	92	814	49	434	147	1301						
	30	27	239	50	443	38	336	95	841						
	50	39	345	98	867	55	487	186	1646					0.413	0.421
	80	63	558	137	1212	87	770	255	2257	7,500	5,600	5,600	3,500	(1.070)	(1.090)
	100	67	593	157	1389	108	956	284	2513					(0.320)	(0.327)
32	120	67	593	167	1478	108	956	304	2690						
	160	67	593	176	1558	108	956	314	2779						
	30	54	478	100	885	75	664	200	1770						
	50	76	673	216	1912	108	956	382	3381					1.69	1.72
	80	118	1044	304	2690	167	1478	568	5027	7,000	4,800	4,600	3,500	(2.85)	(2.91)
	100	137	1212	333	2947	216	1912	647	5726					(1.20)	(1.22)
40	120	137	1212	353	3124	216	1912	686	6071						
	160	137	1212	372	3292	216	1912	686	6071						
	50	137	1212	402	3558	196	1735	686	6071						
	80	206	1823	519	4593	284	2513	980	8673					4.50	4.59
	100	265	2345	568	5027	372	3292	1080	9558	5,600	4,000	3,600	3,000	(9.28)	(9.47)
45	120	294	2602	617	5460	451	3991	1180	10443					(3.41)	(3.48)
	160	294	2602	647	5726	451	3991	1180	10443						
	50	176	1558	500	4425	265	2345	950	8408						
	80	313	2770	706	6248	390	3452	1270	11240					8.68	8.86
	100	353	3124	755	6682	500	4425	1570	13895	5,000	3,800	3,300	3,000	(13.8)	(14.1)
50 ^{*1}	120	402	3558	823	7284	620	5487	1760	15576					(5.80)	(5.92)
	160	402	3558	882	7806	630	5576	1910	16904						
	50	245	2168	715	6328	350	3098	1430	12656						
	80	372	3292	941	8328	519	4593	1860	16461					12.5	12.8
	100	470	4160	980	8673	666	5894	2060	18231	4,500	3,500	3,000	2,500	(25.2)	(25.7)
58 ^{*1}	120	529	4682	1080	9558	813	7195	2060	18231					(9.95)	(10.2)
	160	529	4682	1180	10443	843	7461	2450	21683						
	50	353	3124	1020	9027	520	4602	1960	17346						
	80	549	4859	1480	13098	770	6815	2450	21683					27.3	27.9
	100	696	6160	1590	14072	1060	9381	3180	28143	4,000	3,000	2,700	2,200	(49.5)	(50.5)
58 ^{*1}	120	745	6593	1720	15222	1190	10532	3330	29471					(20.5)	(20.9)
	160	745	6593	1840	16284	1210	10709	3430	30356						

Note: *1 Component type in sizes 50 and over with gear ratio 50:1 use oil lubrication. If it is necessary to use grease, the rated torque is reduced by 50%.

*2 The moment of inertia : $I = 1/4 GD^2$, reflected to input side (wave generator).

Row indicates unit type.

Top: Component type

Middle: (Hollow Type 2UH)

Bottom: (Shaft Type 2UJ)

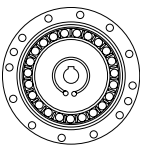

Definition of Ratings

Rated Torque (Tr)

Rated torque indicates allowable continuous load torque at 2000 rpm input speed.

Limit for Repeated Peak Torque (refer to figure 1)

During acceleration a deceleration the Harmonic Drive® gear experiences a peak torque as a result of the moment of inertia of the output load.

Limit for Average Torque

In cases where load torque and input speed vary, it is necessary to calculate an average value of load torque. The table indicates the limit for average torque. The average torque calculated must not exceed this limit.

Limit for Momentary Peak Torque (refer to figure 1)

The gear may be subjected to momentary peak torques in the event of a collision or emergency stop. The magnitude and frequency of occurrence of such peak torques must be kept to a minimum and they should, under no circumstance, occur during normal operating cycle. The allowable number of occurrences of the momentary peak torque may be calculated by using equation 1 on page 12. Also see section "strength and life".

Figure 1

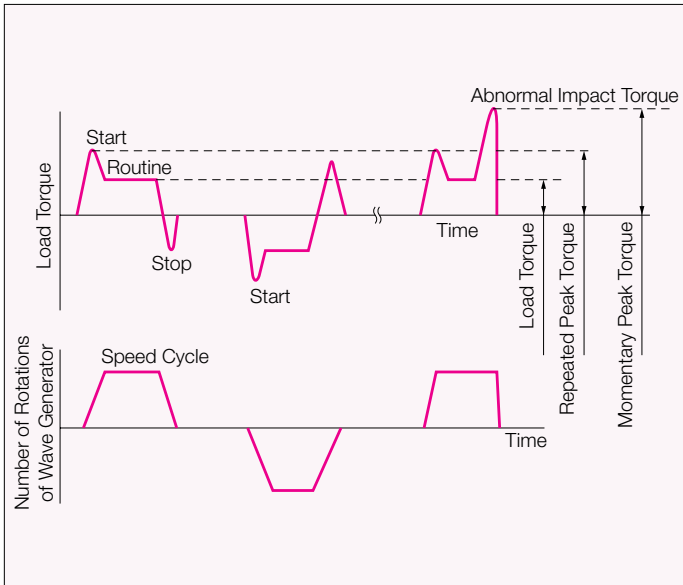

Maximum Input Speed, Limit for average input speed

Do not exceed the allowable rating.

Moment of Inertia

The rating indicates the moment of inertia reflected to the wave generator (gear input).

Strength and Life

The non-rigid Flexspline is subjected to repeated deflections, and its strength determines the torque capacity of the Harmonic Drive® gear. The values given for Rated Torque at Rated Speed and for the allowable Repeated Peak Torque are based on an infinite fatigue life for the Flexspline.

The torque that occurs during a collision must be below the momentary peak torque (impact torque). The maximum number of occurrences is given by the equation below.

[Equation 1]

$$N = \frac{1.0 \times 10^4}{2 \times \frac{n \times t}{60}}$$

n: Input speed before collision
t: Time interval during collision

Please note:

If this number is exceeded, the Flexspline may experience a fatigue failure.

Ratcheting phenomenon

When excessive torque is applied while the gear is in motion, the teeth between the Circular Spline and Flexspline may not engage properly. This phenomenon is called ratcheting and the torque at which this occurs is called ratcheting torque. Ratcheting may cause the Flexspline to become non-concentric with the Circular Spline. (See figure 1 & 2 on page 12) Operating in this condition may result in shortened life and a Flexspline fatigue failure.

Figure 2

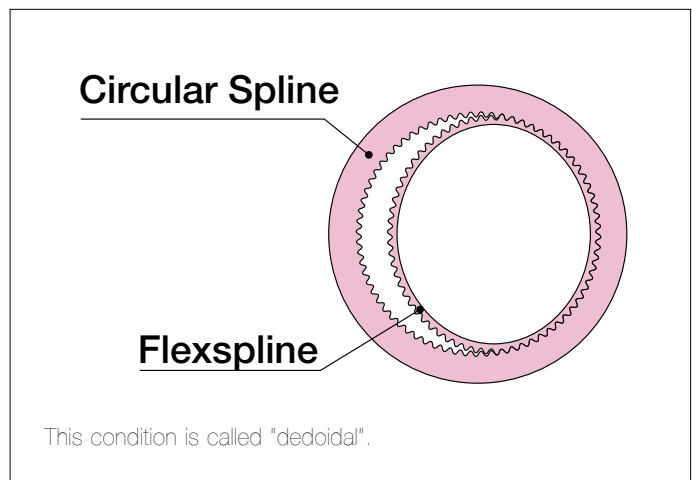

Note!

When ratcheting occurs, the teeth mesh abnormally as shown above.

Vibration and Flexspline damage may occur.

Once ratcheting occurs, the teeth wear excessively and the ratcheting torque may be lowered.

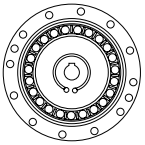

SHF Ratcheting Torque Table 3

Size	Ratio						Nm
	30	50	80	100	120	160	
11	-	34	-	43	-	-	
14	59	88	110	84	-	-	
17	100	150	200	160	120	-	
20	170	220	350	260	240	220	
25	340	450	680	500	470	450	
32	720	980	1400	1000	980	980	
40	-	1800	2800	2100	1900	1800	
45	-	2700	3900	3100	2800	2600	
50	-	3700	5400	4100	3800	3600	
58	-	5800	8200	6400	5800	5600	

Nm Table 4

SHF Buckling Torque	
Size	All Ratio
11	90
14	190
17	330
20	560
25	1000
32	2200
40	4300
45	5800
50	8000
58	12000

SHG Ratcheting Torque Table 5

Size	Ratio					Nm
	50	80	100	120	160	
14	110	140	100	-	-	
17	190	260	200	150	-	
20	280	450	330	310	280	
25	580	880	650	610	580	
32	1200	1800	1300	1200	1200	
40	2300	3600	2700	2400	2300	
45	3500	5000	4000	3600	3300	
50	-	7000	5300	4900	4600	
58	-	10000	8300	7500	7200	
65	-	14000	12000	10000	10000	

Nm Table 6

SHG Buckling Torque	
Size	All Ratio
14	180
17	350
20	590
25	1100
32	2400
40	4400
45	6300
50	8600
58	13400
65	18800

The Life of a Wave Generator

The normal life of a gear is determined by the life of the wave generator bearing. The life may be calculated by using the input speed and the output load torque.

Rated Lifetime L_n : ($n = 10$ or 50)

L_{10}	SHF : 7,000	SHG: 10,000
L_{50}	SHF : 35,000	SHG : 50,000

Equation for the expected life of the wave generator under normal operating conditions is given by the equation below.

[Equation 2]

$$L_h = L_n \cdot \left(\frac{T_r}{T_{av}}\right)^3 \cdot \left(\frac{N_r}{N_{av}}\right)$$

L_h : Expected Life, hours

L_n : Rated Lifetime at L_{10} or L_{50}

T_r : Rated Torque (Tables 1, 2, 3)

N_r : Rated input speed (2000 rpm)

T_{av} : Average load torque on output side (page 14)

N_{av} : Average input speed (page 14)

Relative Torque Rating

The chart below shows the various torque specifications relative to rated torque. Rated Torque has been normalized to 1 for comparison.

Figure 3

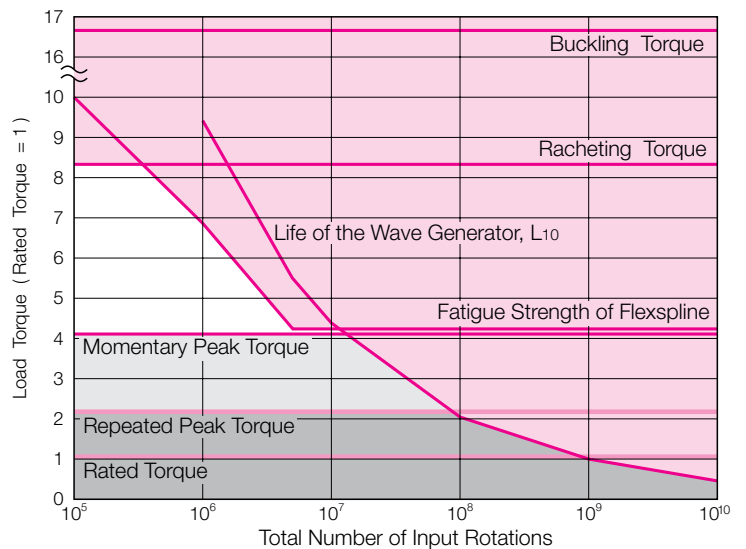

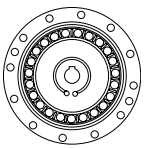

Size Selection

Generally, the operating conditions consist of fluctuating torques and output speeds. Also, an unexpected impact output torque must be considered.

The proper size can be determined by converting fluctuating load torque into average load torque and equivalent load torque. This procedure involves selecting the size based on load torque for component sets.

This procedure does not consider the life of the output bearing for housed units. Determining the life of the output bearing for various axial, radial, and moment loads is outlined on page 34.

Figure 4

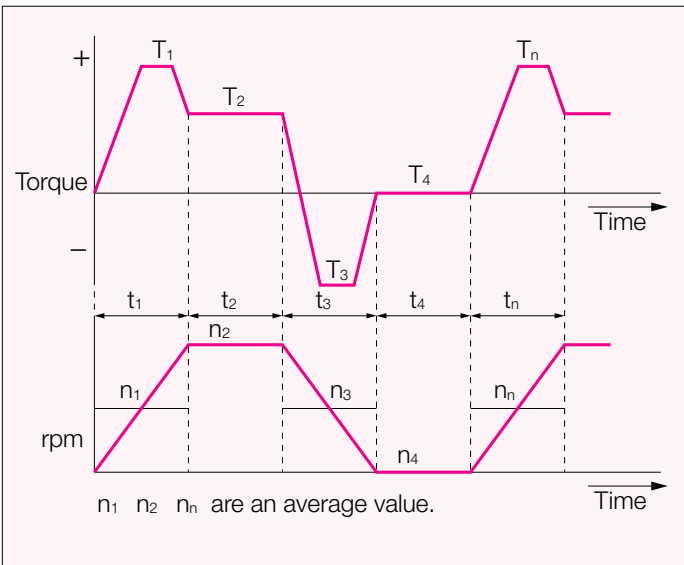

Parameters	
Load Torque	Tn (Nm)
Time	tn (sec)
Output Speed	nn (rpm)
Normal Operating Pattern	
Acceleration	T1,t1, n1
Regular Operation	T2,t2, n2
Deceleration	T3,t3, n3
Dwell	T4,t4, n4
Maximum RPM	
Max output speed	no maximum
Max input speed	ni maximum
Impact Torque	
	Ts,ts, ns
Ratings	
Rated Torque	Tr
Rated Speed	nr =2000 rpm

Flow Chart for selecting a size

Please use the flowchart shown below for selecting a size. Operating conditions must not exceed the performance ratings as described on page 12.

Calculation of the average output torque

$$T_{av} = \sqrt[3]{\frac{n_1 \cdot t_1 \cdot |T_1|^3 + n_2 \cdot t_2 \cdot |T_2|^3 + \dots + n_n \cdot t_n \cdot |T_n|^3}{n_1 \cdot t_1 + n_2 \cdot t_2 + \dots + n_n \cdot t_n}}$$

Selection of tentative size under the condition shown below.

Average Output Speed

$$n_{o\ av} = \frac{n_1 \cdot t_1 \cdot n_2 \cdot t_2 + \dots + n_n \cdot t_n}{t_1 + t_2 + \dots + t_n}$$

Determine Gear Ratio

$$\frac{n_i\ max}{n_o\ max} \leq R$$

$n_i\ max$ may be limited by the motor.

Calculation of the average input speed

$$n_i\ av = n_o\ av \cdot R$$

Calculation of maximum input speed

$$n_i\ max = n_o\ max \cdot R$$

NG

$n_i\ av \leq$ Limit for average speed
 $n_i\ max \leq$ Limit for maximum speed

OK

NG

Confirm if T_1 and T_3 are less than the repeated peak torque specification.

OK

NG

Confirm if T_s (impact torque) is less than the momentary peak torque specification.

OK

NG

Calculate the allowable number of rotations during impact torque.

$$N_s = \frac{10^4}{2 \cdot n_s \cdot R \cdot t_s} \dots N_s \leq 1.0 \times 10^4$$

OK

Calculate wave generator life.

$$L_h = L_n \cdot \left(\frac{T_r}{T_{av}}\right)^3 \cdot \left(\frac{nr}{n_i\ av}\right)$$

NG

Make sure that the calculated life is suitable for the application.

OK

The model number is determined.

Consider a different Size or change operating requirements

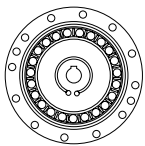

SELECTION PROCEDURE

Values of an each Load Torque Pattern

Load Torque	Tn (Nm)	no max = 14 rpm
Time	tn (sec)	ni max = 1800 rpm
Output Speed	nn (rpm)	

Normal Operating Pattern

Acceleration	T1 = 400 Nm,	t1 = 0.3 sec,	n1 = 7 rpm	Ts = 500 Nm, ts = 0.15 sec, ns = 14 rpm
Regular Operation Stop	T2 = 320 Nm,	t2 = 3 sec,	n2 = 14 rpm	
Deceleration	T3 = 200 Nm,	t3 = 0.4 sec,	n3 = 7 rpm	L10 = 7000 hrs.
Dwell	T4 = 0 Nm,	t4 = 0.2 sec,	n4 = 0 rpm	Oil Lubrication

Tav (Nm)

$$T_{av} = \sqrt[3]{\frac{7\text{rpm} \cdot 0.3\text{sec} \cdot |400\text{Nm}|^3 + 14\text{rpm} \cdot 3\text{sec} \cdot |320\text{Nm}|^3 + 7\text{rpm} \cdot 0.4\text{sec} \cdot |200\text{Nm}|^3}{7\text{rpm} \cdot 0.3\text{sec} + 14\text{rpm} \cdot 3\text{sec} + 7\text{rpm} \cdot 0.4\text{sec}}}$$

$$T_{av} = 319\text{Nm} < 451\text{Nm} \text{ (for SHF-40-120-2A-GR)}$$

no av (rpm)

$$no_{av} = \frac{7\text{rpm} \cdot 0.3\text{sec} + 14\text{rpm} \cdot 3\text{sec} + 7\text{rpm} \cdot 0.4\text{sec}}{0.3\text{sec} + 3\text{sec} + 0.4\text{sec} + 0.2\text{sec}} = 12\text{rpm}$$

(R)

$$\frac{1800\text{rpm}}{14\text{rpm}} = 128.6 > 120$$

$$n_i av = 12\text{rpm} \cdot 120 = 1440\text{rpm}$$

$$n_o max = n_i max \text{ (rpm)}$$

$$n_i max = 14\text{rpm} \cdot 120 = 1680\text{rpm}$$

$$n_i av = 1440\text{rpm} < 3600\text{rpm} \text{ (for SHF-40-120-2A-GR)}$$

$$n_i max = 1680\text{rpm} < 5600\text{rpm} \text{ (for SHF-40-120-2A-GR)}$$

OK

T₁, T₃ (Nm)

$$T_1 = 400\text{Nm} < 617\text{Nm} \text{ (for SHF-40-120-2A-GR)}$$

$$T_3 = 200\text{Nm} < 617\text{Nm} \text{ (for SHF-40-120-2A-GR)}$$

OK

T_s (Nm)

$$T_s = 500\text{Nm} < 1180\text{Nm} \text{ (for SHF-40-120-2A-GR)}$$

OK

(N_s) Calculate an allowable number of rotation (Ns) and confirm $\leq 1.0 \times 10^4$

$$N_s = \frac{10^4}{2 \cdot \frac{14\text{rpm} \cdot 120}{60} \cdot 0.15\text{sec}} = 1190 < 1.0 \times 10^4$$

OK

Calculate life

$$L_{10} = 7000 \cdot \left(\frac{294\text{Nm}}{319\text{Nm}}\right)^3 \cdot \left(\frac{2000\text{rpm}}{1440\text{rpm}}\right)$$

$$L_{10} = 7610 > 7000 \text{ (L}_{B10}\text{)}$$

OK

SHF-40-120-2A-GR

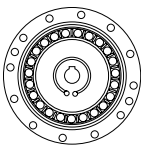

DIMENSION AND SHAPE

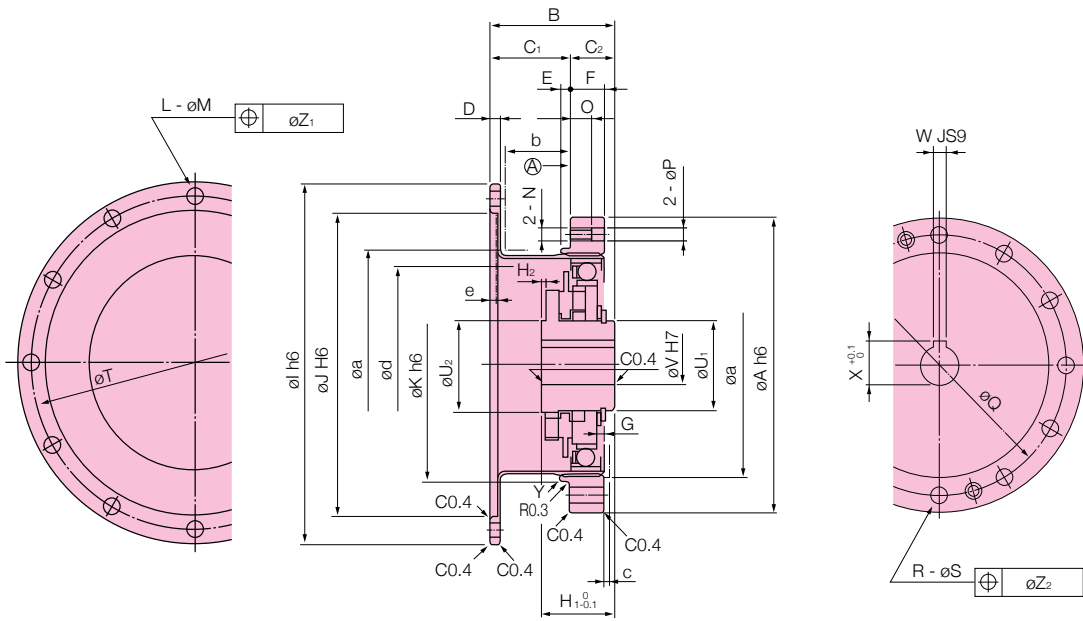

No key on WG hub for #14 and #17

Detail drawings are also available

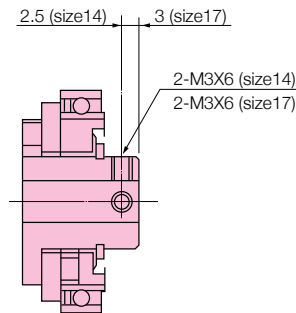

WAVE GENERATOR COMPONENTS

- ① Ball Separator
- ② Wave Generator Bearing
- ③ Wave Generator Plug
- ④ Insert
- ⑤ Rub Washer
- ⑥ Snap Ring
- ⑦ Wave Generator Hub

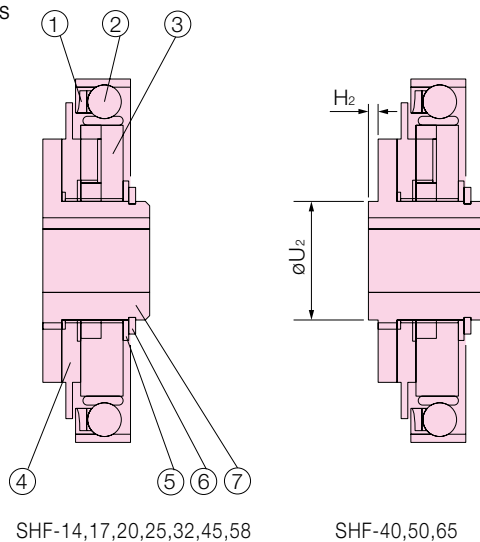

There is a difference of the ball separator between SHF and SHG.
(SHG size 14 and 17 use the same ball separator as SHF)



SHF ALL SIZES
SHG - 14, 17, 65



SHG-20 AND ABOVE

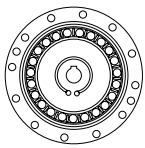

EXTERNAL DIMENSIONS

Table 7

(mm)

	14	17	20	25	32	40	45	50	58	65	
øA h6	50	60	70	85	110	135	155	170	195	215	
B	SHF	28.5 ⁰ _{-0.8}	32.5 ⁰ _{-0.9}	33.5 ⁰ _{-1.0}	37 ⁰ _{-1.0}	44 ⁰ _{-1.1}	53 ⁰ _{-1.1}	58.5 ⁰ _{-1.2}	64 ⁰ _{-1.3}	75.5 ⁰ _{-1.3}	–
	SHG	28.5 ⁰ _{-0.4}	32.5 ⁰ _{-0.4}	33.5 ⁰ _{-0.4}	37 ⁰ _{-0.5}	44 ⁰ _{-0.6}	53 ⁰ _{-0.6}	58.5 ⁰ _{-0.6}	64 ⁰ _{-0.7}	75.5 ⁰ _{-0.7}	83 ⁰ _{-0.7}
C ₁	17.5 ^{+0.4} ₀	20 ^{+0.5} ₀	21.5 ^{+0.8} ₀	24 ^{+0.8} ₀	28 ^{+0.8} ₀	34 ^{+0.6} ₀	38 ^{+0.6} ₀	41 ^{+0.6} ₀	48 ^{+0.6} ₀	52.5 ^{+0.6} ₀	
C ₂	11	12.5	12	13	16	19	20.5	23	27.5	30.5	
D	2.4	3	3	3.3	3.6	4	4.5	5	5.8	6.5	
E	2	2.5	3	3	3	4	4	4	5	5	
F	6	6.5	7.5	10	14	17	19	22	25	29	
G	SHF	0.4	0.3	0.1	2.1	2.5	3.3	3.7	4.2	4.8	–
	SHG	1.4	1.6	1.5	3.5	4.2	5.6	6.3	7	8.2	9.5
H ₁	SHF	17.6 ⁰ _{-0.1}	19.5 ⁰ _{-0.1}	20.1 ⁰ _{-0.1}	20.2 ⁰ _{-0.1}	22 ⁰ _{-0.1}	27.5 ⁰ _{-0.1}	27.9 ⁰ _{-0.1}	32 ⁰ _{-0.1}	34.9 ⁰ _{-0.1}	–
	SHG	18.5 ⁰ _{-0.1}	20.7 ⁰ _{-0.1}	21.5 ⁰ _{-0.1}	21.6 ⁰ _{-0.1}	23.6 ⁰ _{-0.1}	29.7 ⁰ _{-0.1}	30.5 ⁰ _{-0.1}	34.8 ⁰ _{-0.1}	38.3 ⁰ _{-0.1}	44.6 ⁰ _{-0.11}
H ₂	–	–	–	–	–	0.4	–	0.8	–	2.2	
øh6	SHF	60	72	82	104	134	164	182	205	233	–
	SHG	60	72	82	104	134	164	190	214	240	276
øH6	48	60	70	88	114	140	158	175	203	232	
(other than 30:1 øKh6)	30:1 (only)	38	48	54	67	90	110	124	135	156	177
	L	8	12	12	12	12	12	18	12	16	16
øM	3.5	3.5	3.5	4.5	5.5	6.6	6.6	9	9	11	
N	M3	M3	M3	M4	M5	M6	M8	M8	M10	M10	
O	6	6.5	4	6	7	9	12	13	15	15	
øP	–	–	3.5	4.5	5.5	6.6	9	9	11	11	
Q	44	54	62	75	100	120	140	150	175	195	
R	SHF	6	12	12	12	12	12	12	12	–	
	SHG	8	16	16	16	16	16	16	16	16	
øS	3.5	3.5	3.5	4.5	5.5	6.6	9	9	11	11	
T	SHF	54	66	76	96	124	152	170	190	218	–
	SHG	54	66	76	96	124	152	180	200	226	258
øU ₁	14	18	21	26	26	32	32	32	40	48	
øU ₂	–	–	–	–	–	32	–	32	–	48	
øV	(H7) standard	6	8	9	11	14	14	19	19	22	24
	maximum	8	10	13	15	15	20	20	20	25	30
WJs9	–	–	3	4	5	5	6	6	6	8	
X	–	–	10.4 ^{+0.1} ₀	12.8 ^{+0.1} ₀	16.3 ^{+0.1} ₀	16.3 ^{+0.1} ₀	21.8 ^{+0.1} ₀	21.8 ^{+0.1} ₀	24.8 ^{+0.1} ₀	27.3 ^{+0.2} ₀	
Y	00.3	00.4	00.4	00.4	00.4	00.4	00.4	00.8	00.8	00.8	
øZ ₁	0.25	0.25	0.25	0.25	0.25	0.3	0.3	0.5	0.5	0.5	
øZ ₂	0.25	0.25	0.25	0.25	0.25	0.3	0.5	0.5	0.5	0.5	
øa	øa	38	45	53	66	86	106	119	133	154	172
	b	14.6	16.4	17.8	19.8	23.2	28.6	31.9	34.2	40.1	43
	c	1	1	1.5	1.5	1.5	2	2	2	2.5	2.5
	ød	31	38	45	56	73	90	101	113	131	150
	e	1.7	2.1	2.0	2.0	2.0	2.0	2.3	2.5	2.9	3.5
Weight (kg)	0.11	0.18	0.31	0.48	0.97	1.87	2.64	3.53	5.17	7.04	

Component Type

- Installed surface on Circular Spline is shown as (A). Use this surface for installation in Case.
- Dimensions shown below maybe modified as a special order.

Wave Generator : V
 Flexspline : L and M
 Circular Spline : R and S

- Dimensions for B, C₁, C₂ must meet the tolerance values shown above.
- Due to the deformation of the Flexspline during operation, it is necessary to provide a minimum housing clearance. (Dimensions øa to e)

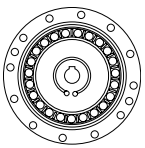

LUBRICATION

Grease lubricant is the standard for the SHF unit. The temperature range is shown below. (Exceptions are shown on page 18.)

Lubricant	Type	Temperature
Grease	Harmonic Grease SK-1A	0°C~+40°C
Grease	Harmonic Grease SK-2	0°C~+40°C
Grease	Harmonic Grease 4B-No.2	-10°C~+70°C
Oil	Industrial gear oil #2(high pressure) ISO VG68	0°C~+40°C

Harmonic Grease SK-1A - This grease is developed for a Harmonic Drive® gear and features good durability and efficiency.

Harmonic Grease SK-2 - This grease is developed for a small size Harmonic Drive® gear and features smooth rotation of the Wave Generator since high pressure additive is liquefied.

Harmonic Grease 4BNo.2 - This grease is developed for Harmonic Drive® gears and features long life and a wide range of temperature.

Note 1 - Grease lubrication must have proper sealing, this is essential for 4B No.2.

Rotating part: Oil seal with spring is needed.

Mating part: O ring or seal adhesive is needed.

Note 2 - The grease has the highest deterioration rate in the region where the grease is subjected to the greatest shear (near wave generator). Its viscosity is between JIS No.0 and No.00 depending on the operation.

Ratio 30:1

Size	14	17	20	25	32
SK-1A	—	—	O	O	O
SK-2	O	O	—	—	—
4BNo.2	Δ	Δ	●	●	●

●: recommended grease for long life and high load O: Standard Δ: Semistandard

Ratio 50:1 and above

Size	14	17	20	25	32	40	45	50	58	65
SK-1A	—	—	O	O	O	O	O	O	O	O
SK-2	O	O	Δ	Δ	Δ	Δ	—	—	—	—
4BNo.2	●	●	●	●	●	●	●	●	●	●

●: recommended grease for long life and high load O: Standard Δ: Semistandard

Characteristics of Grease

Grease	SK-1A	SK-2	4BNo.2
Durability	O	O	●
Fretting Resistance	O	O	●
Low Temp	Δ	Δ	●
Grease Leakage	●	●	Δ

●: Excellent O: Good Δ: Exercise Caution

Recommended Grease

Grease	SK-1A	SK-2	4B No.2
Base Oil	Refined mineral hydrocarbon base oil	Refined mineral hydrocarbon base oil	Hydrocarbon type synthetic oil and polymer
Thickening Agent	Lithium soap thickener	Lithium soap thickener	Urea
Additive	Organic molybdenum, etc.	Organic molybdenum, etc.	Organic molybdenum, etc.s
NLGI Consistency No.	No.2	No.2	No.1.5
Viscosity (25C) cSt	265 to 295	265 to 295	290 to 320
Melting Point	197°C	198°C	247°C
Color	Yellow	Green	Light Yellow
Life	5 Years in Airtight Container		

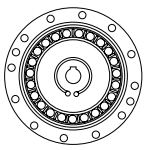

Recommended Dimensions for Inner Case

Recommended dimensions for inner case must meet with numbers shown below. These dimensions must be maintained to prevent damage to the gear and to maintain a proper grease cavity.

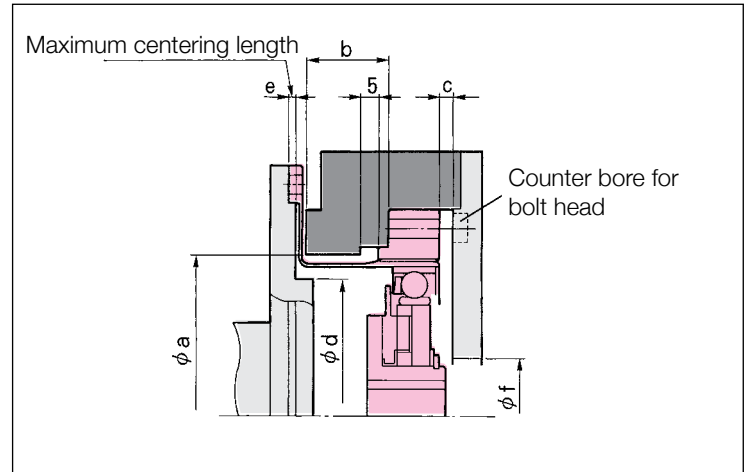

Recommended Dimensions for Inner Case Table 8

Unit: mm

Size	14	17	20	25	32	40	45	50	58	65
øa	38	45	53	66	86	106	119	133	154	172
b	14.6	16.4	17.8	19.8	23.2	28.6	31.9	34.2	40.1	43
c	1(3)	1(3)	1.5(4.5)	1.5(4.5)	1.5(4.5)	2(6)	2(6)	2(6)	2.5(7.5)	2.5(7.5)
ød	31	38	45	56	73	90	101	113	131	150
e	1.7	2.1	2.0	2.0	2.0	2.0	2.3	2.5	2.9	3.5
øf	16	26	30	37	37	45	45	45	56	62

Note: Values in parenthesis show the value when the Wave Generator is pointing up.

Flexspline

Wave generator

Circular Spline

Input Cover (Motor Flange)

Note: Fill cavity between Wave Generator and Input Cover (Motor Flange) with grease, when the Wave Generator is used for vertical installation. (page 21, Figure 3)

Grease Usage Table 9

Unit: g

Size	14	17	20	25	32	40	45	50	58	65
amount	5.5	10	16	40	60	130	180	260	360	460

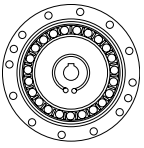

Grease Change

The wear characteristics of the gear are strongly influenced by the condition of the grease lubrication. The condition of the grease is affected by the ambient temperature. The graph shows the maximum number of input rotations for various temperatures. This graph applies to applications where the average load torque does not exceed the rated torque.

In cases where the rated torque is exceeded, calculate the grease change interval using the equation shown below.

Equation where average load torque exceeds rated torque

[Equation 3]

$$L_{GT} = L_{GTn} \times \left(\frac{T_r}{T_{av}} \right)^3$$

Symbol of Equation	
L_{GT}	Grease change (over rated torque), input rotations
L_{GTn}	Grease change (below rated torque), input rotations (From Graph)
T_r	Rated Torque
T_{av}	Average load torque on output

Grease Change Interval for $T_{av} < T_r$ L_{GTn}

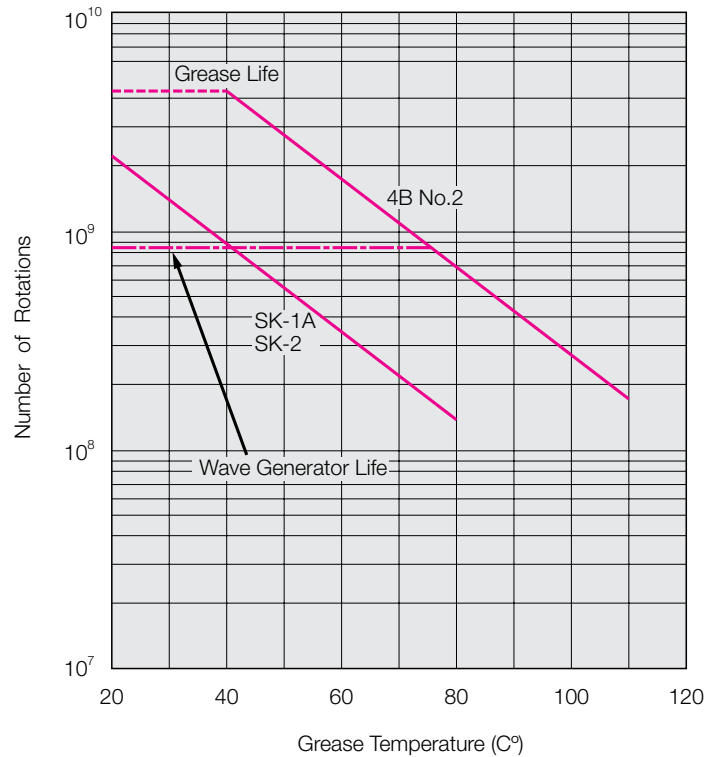

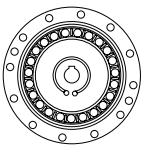

Oil Lubricant

Name of Lubricant Table 10

Industrial	Mobil	Exxon	Showa Shell	Cosmo	Japan Energy	Shin Nippon Oil	Idemitsu Kosan	General oil	NOK Krewba
Industrial Gear Oil#2 ISO VG68 (extreme pressure)	Mobil gear 626	Spartan EP68	Omara oil 68	Cosmo gear SE68	ES gear G68	Bonnock AX68 M68	Dafuni Supergear LW68	General Oil SP gear Roll 68	Shin tessō DE-68 EP

Oil Level of Horizontal Usage Table 11

Size	14	17	20	25	32	40	45	50	58	65
A	10	12	14	17	24	31	35	38	44	50

Horizontal Installation:

Oil level should be maintained at the level "A" as shown.

Oil Level for Horizontal Usage

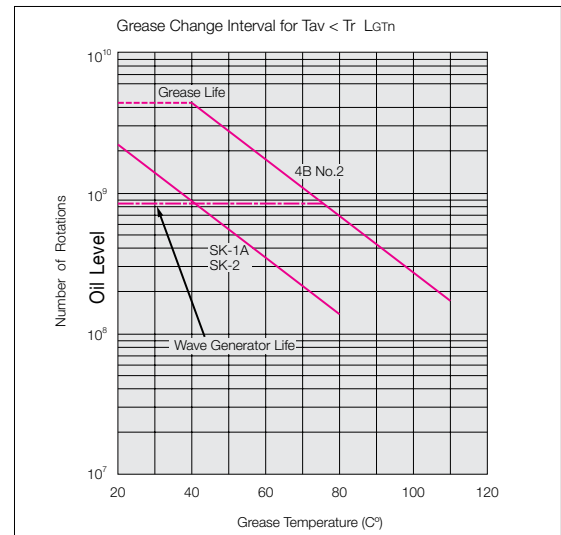

Oil Level of Vertical Usage Table 12

Size	14	17	20	25	32	40	45	50	58	65
B	2.5	3	3	5	7	9	10	12	13	15

Vertical Installation:

If the input shaft is on top, lube holes are provided on the boss of the Flexspline to facilitate the flow of oil inside the Flexspline cup. The lube holes serve as breathers if the component set is used with input down.

When the Harmonic Drive® gear is to be used vertically with the Wave Generator placed at the bottom, special consideration must be given. If the Wave Generator assembly is completely submerged in oil, the heat generation caused by churning oil will be substantial and a loss of efficiency will result. It is recommended that the oil level be maintained in such a way that approximately one half of the Wave Generator Bearing is submerged. Oil level should be maintained at the level "B" shown.

To ensure a sufficient amount of lubricant it may be necessary to extend the bottom area of the housing or to provide an external oil reservoir. A forced lubrication system may also be considered.

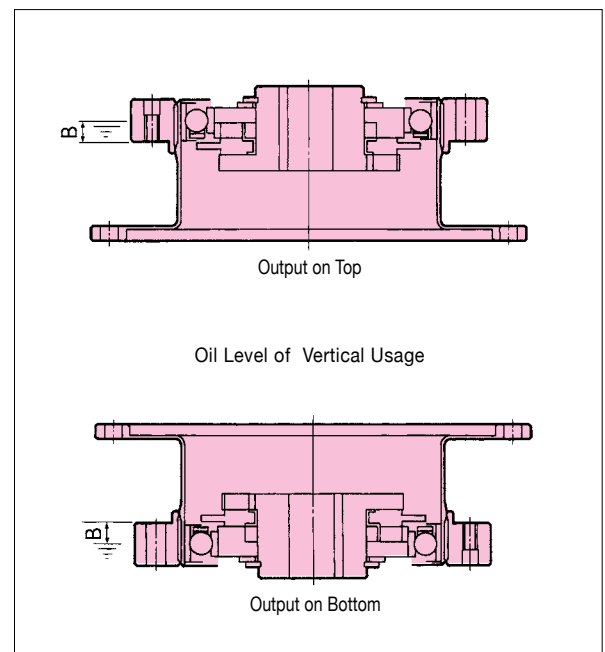

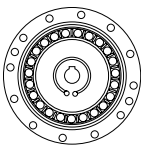

Example of Oil Channeling to the Flexspline Interface.

When oil is used as lubrication, the flange connected to the Flexspline must have a passage for oil to flow through. This allows for proper oil circulation. (Refer to Figure 4)

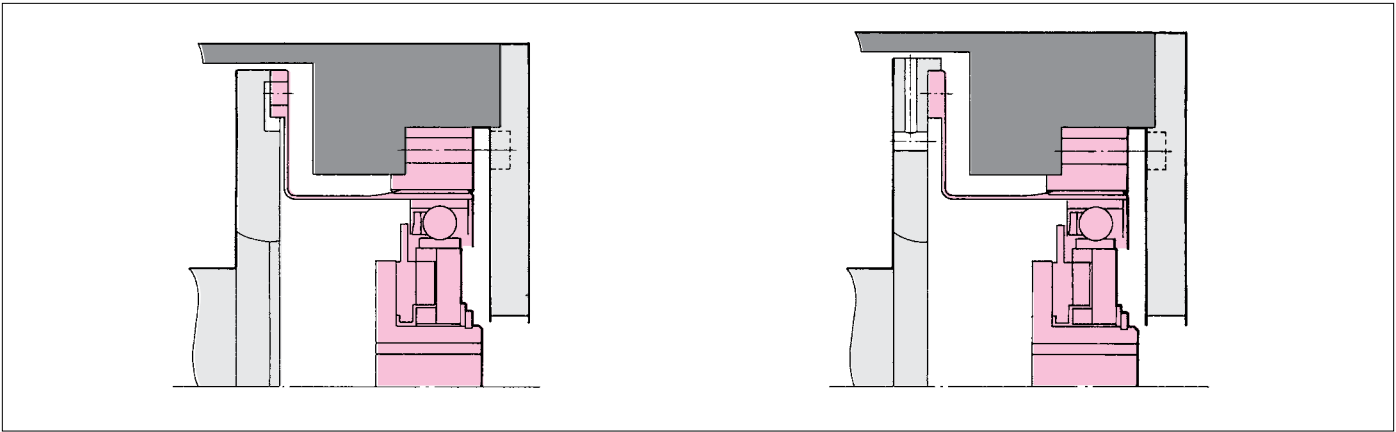

Oil Quantity											Table 13 mm
Size	14	17	20	25	32	40	45	50	58	65	
Amount	0.01	0.02	0.03	0.07	0.13	0.25	0.32	0.4	0.7	1.0	

Oil Change

- The first oil change should be performed after 100 hours of operation.
- The need to perform subsequent oil changes will depend on operating conditions, but should take place at intervals of approximately 1000 running hours.

Other notes: Avoid mixing different kinds of oil. The gear should be in an individual case when installed.

Special Lubricants for Extreme Temperatures

In extreme temperature environments (Exceptions are shown on page 18), please consider the following lubricant temperature range and condition, and select type of lubricant.

Harmonic Grease 4B No.2

Lubricant	Standard Temperature	Possible Temperature
grease	-10°C~+110°C	-50°C~+130°C

High Temperature Lubricant

Lubricant	Name and Manufacturer	Possible Temperature
Mobil Grease 28	Mobil Grease 28	-5°C~+160°C
Oil	Mobil SHC-626	-5°C~+140°C

Low Temperature Lubricant

Lubricant	Name & Manufacturer	Possible Temperature
grease	Multemp SH-K11 Kyodo Yushi	-30°C~+50°C
	Iso Flex LDS-18 special A NOK krewba	-25°C~+80°C
oil	SH-200-100CS Tore Silicon	-40°C~+140°C
	Shintesso D-32EP:NOK krewba	

1. Standard temperature range is Harmonic Grease 4B No.2 is the grease temperature during operation. This grease has been developed for improved performance of Harmonic Drive® gears.
2. Possible temperature range indicates temperature of individual lubricant. It will cause restriction on operating condition (Rated torque, In-put and Out-put speed and operating cycle etc.). If ambient temperature is lowest or highest temperature, it is necessary to change the materials, please contact us.
3. The temperature range of the grease can be extended as indicated in the possible temperature range shown. At the low end of this range the efficiency will be low due to an increase in viscosity of the lubricant. At the high end of this range the lubricant life will be low due to an increased deterioration rate from the high temperature.

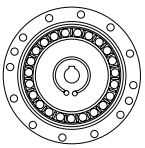

RECOMMENDED TOLERANCES FOR ASSEMBLY

For peak performance of the SHF Component Set it is essential that the following tolerances be observed when assembly is complete.

Recommended tolerances for assembly

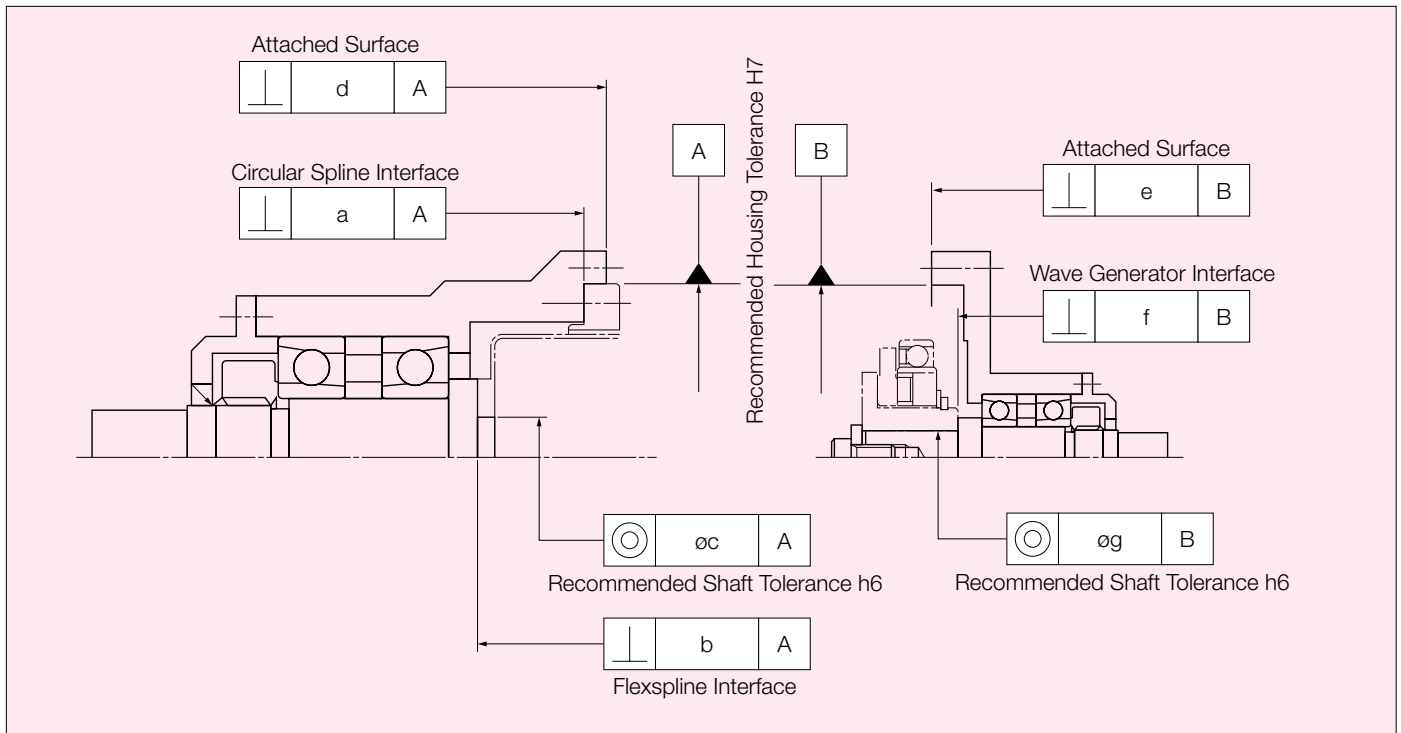

Tolerances for Assembly Table 14

Size	14	17	20	25	32	40	45	50	58	65	unit:mm
a	0.011	0.012	0.013	0.014	0.016	0.016	0.017	0.018	0.020	0.023	
b	0.016	0.021	0.027	0.035	0.042	0.048	0.053	0.057	0.062	0.067	
øc	0.015	0.018	0.019	0.022	0.022	0.024	0.027	0.030	0.032	0.035	
d	0.011	0.015	0.017	0.024	0.026	0.026	0.027	0.028	0.031	0.034	
e	0.011	0.015	0.017	0.024	0.026	0.026	0.027	0.028	0.031	0.034	
f	0.017	0.020	0.024	0.024	0.024	0.032	0.032	0.032	0.032	0.032	
	(0.008)	(0.010)	(0.012)	(0.012)	(0.012)	(0.012)	(0.013)	(0.015)	(0.015)	(0.015)	
øg	0.030	0.034	0.044	0.047	0.050	0.063	0.065	0.066	0.068	0.070	
	(0.016)	(0.018)	(0.019)	(0.022)	(0.022)	(0.024)	(0.027)	(0.030)	(0.033)	(0.035)	

The values in parentheses indicate that Wave Generator does not have an Oldham coupling.

Sealing structure

A seal structure is needed to maintain the high durability of gears and prevent grease leakage.

Key Points to Verify

- Rotating parts should have an oil seal (with spring), surface should be smooth (no scratches)
- Mating flanges should have an O Ring, seal adhesive
- Screws should have a thread lock
(Loctite 242 recommended) or seal adhesive.

(note)

If you use Harmonic Grease 4BNo.2, strict sealing is required.

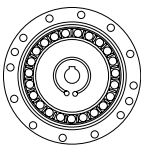

DIAMETER

Hole Diameter of Wave generator Hub

Table 15 Unit: mm

Size	14	17	20	25	32	40	45	50	58	65
Standard Dimension	6	8	9	11	14	14	19	19	22	24
Minimum Hole Dimension	3	4	5	6	6	10	10	10	13	16
Maximum Hole Dimension	8	10	13	15	15	20	20	20	25	30

Hole Diameter of Wave Generator

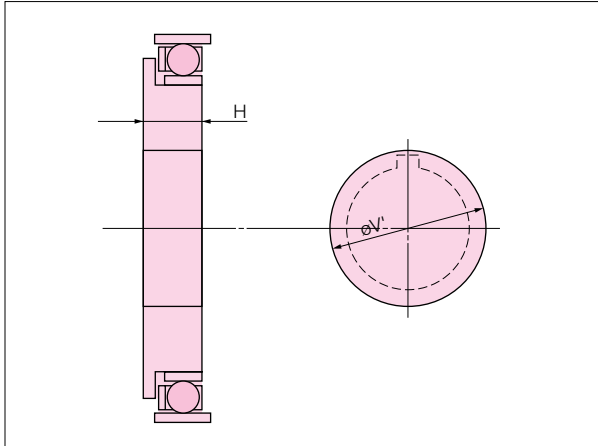

Installation of Three Basic Elements

Installation for Wave Generator and the maximum hole dimensions.

Shown above is the standard hole dimension of the Wave Generator for each size. The dimension can be changed within a range up to the maximum hole dimension shown in table 15. We recommend the dimension of keyway based on JIS standard. It is necessary that the dimension of keyways should sustain the transmission torque.

Please note: Tapered holes are also available.

In cases where a larger hole is required, use the Wave Generator without the Oldham coupling. The maximum diameter of the hole should be considered to prevent deformation of the Wave Generator plug by load torque.

The dimension is shown in table 16 include the dimension of depth of keyway.

Maximum Diameter or Hole without Coupling

Table 16 Unit: mm

Size	14	17	20	25	32	40	45	50	58	65
Maximum Diameter $\phi V'$	17	20	23	28	36	42	47	52	60	67
Min. Thickness of Plug H	7.2	7.6	11.3	11.3	13.7	15.9	17.8	19	21.4	13.5

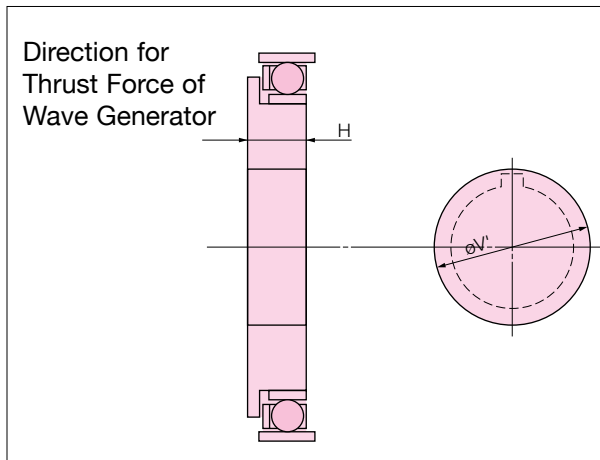

Axial Force of Wave Generator

When a SHF/SHG gear is used to accelerate a load, the deflection of the Flexspline leads to an axial force acting on the Wave Generator. This axial force, which acts in the direction of the closed end of the Flexspline, must be supported by the bearings of the input shaft (motor shaft).

When a SHF/SHG gear is used to decelerate a load, an axial force acts to push the Wave Generator out of the Flexspline cup. Maximum axial force of the Wave Generator can be calculated by the equation shown below.

The axial force may vary depending on its operating condition. The value of axial force tends to be a larger number when using high torque, extreme low speed and constant operation. The force is calculated (approximately) by the equation. In all cases, the Wave Generator must be axially (in both directions), as well as torsionally, fixed to the input shaft.

(note) Please contact us when you fix the Wave Generator hub and input shaft using bolts.

equation 3	Gear Ratio	equation
	$i=1/30$	$F=2x \frac{T}{D} x 0.07 x \tan 32^\circ$
	$i=1/50$	$F=2x \frac{T}{D} x 0.07 x \tan 30^\circ$
	$i=1/80$ and up	$F=2x \frac{T}{D} x 0.07 x \tan 20^\circ$

F	axial force	N
D	HD Size x 0.00254	m
T	output torque	Nm

Calculation Example

size	:	32
Ratio	:	$i=1/50$
Output Torque	:	300Nm
$F=2x \frac{300}{(32x0.00254)} x 0.07 x \tan 30^\circ$		
$F=298N$		

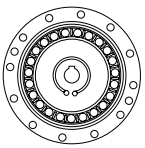

Shape and dimension of Wave Generator

There is a difference between SHF series and SHG series with regard to the shape and dimension of the Wave Generator. Table 17 and Figure 5 show the comparison of the shape and dimension for the Wave Generator. During design and installation, please ensure there is no interference between the bolt of the Wave Generator and Flexspline.

Comparison of Dimension of Wave Generator Hub Table 17

Unit: mm

Size		14	17	20	25	32	40	45	50	58	65
G	SHF	0.4	0.3	0.1	2.1	2.5	3.3	3.7	4.2	4.8	-
	SHG	1.4	1.6	1.5	3.5	4.2	5.6	6.3	7	8.2	9.5
H ¹	SHF	17.6 ⁰ _{-0.1}	19.5 ⁰ _{-0.1}	20.1 ⁰ _{-0.1}	20.2 ⁰ _{-0.1}	22 ⁰ _{-0.1}	27.5 ⁰ _{-0.1}	27.9 ⁰ _{-0.1}	32 ⁰ _{-0.1}	34.9 ⁰ _{-0.1}	-
	SHG	18.5 ⁰ _{-0.1}	20.7 ⁰ _{-0.1}	21.5 ⁰ _{-0.1}	21.6 ⁰ _{-0.1}	23.6 ⁰ _{-0.1}	29.7 ⁰ _{-0.1}	30.5 ⁰ _{-0.1}	34.8 ⁰ _{-0.1}	38.3 ⁰ _{-0.1}	44.6 ⁰ _{-0.1}

Installation of flexspline

For installation, the flange diameter should not exceed the boss diameter of Flexspline shown on figure 5. The flange which contacts the diaphragm should have radius, R. A large diameter and flange without a radius may cause damage to the diaphragm.

Figure 5. Comparison of shape for Wave Generator

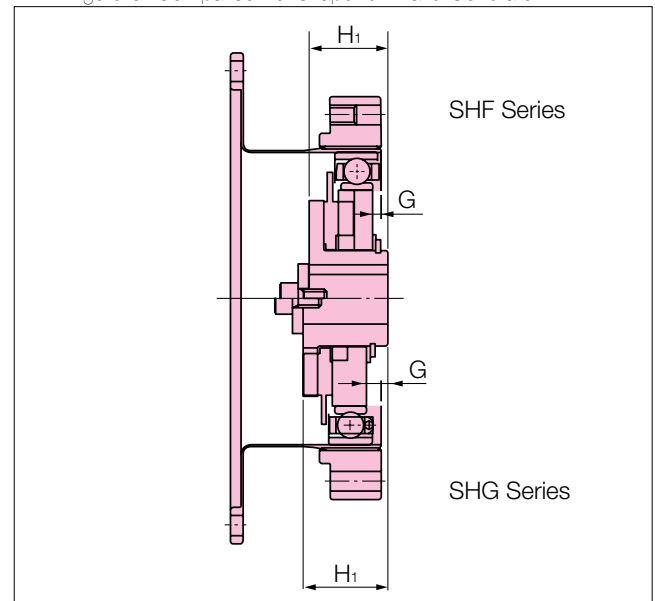

Comparison of Dimension of Flexspline

Table 18

Size	14	17	20	25	32	40	45	50	58	65
øD	48	60	70	88	114	140	158	175	203	232

Figure 6. Installation for Flexspline

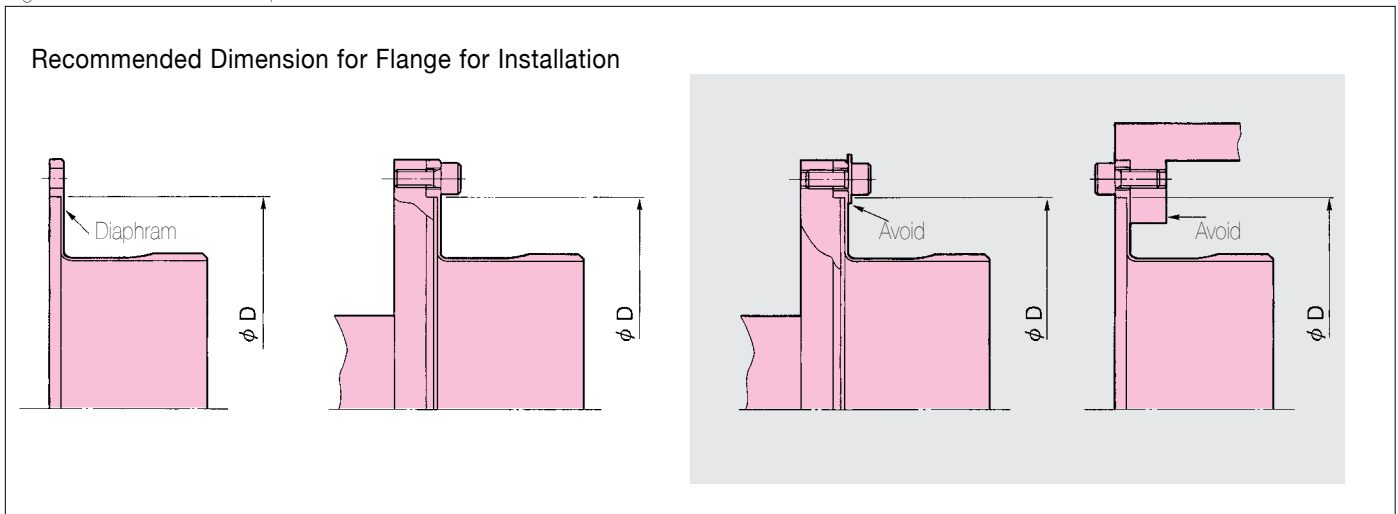

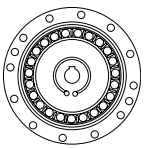

INSTALLATION PROCEDURE

Installation of the Flexspline

The load is normally attached to the Flexspline using a bolt or screw. For high load torques dowel pins can be used in addition to bolts or screws.

The strength of the selected bolt, clamp torque, surface condition of bolt and thread, and coefficient of friction on the contact surface are important factors to consider.

To determine transmission torque of the fastened part consider conditions indicated above.

Please fasten bolts with the proper torque for each size as indicated. Please use the table shown below to decide if dowel pins are needed.

1. If the load torque is less than momentary peak torque shown on tables 1 and 2 then only bolts are needed.

2. If the load torque is expected to reach momentary peak torque, both bolts and pins should be used.

Use values on the list as a reference.

Tables 19, 21 pertain to the SHF series.
Tables 20, 22 pertain to the SHG series.

SHF Series Flexspline Installation

Table 19

Size	14	17	20	25	32	40	45	50	58
Number	8	12	12	12	12	12	18	12	16
Size	M3	M3	M3	M4	M5	M6	M6	M8	M8
Pitch circle	mm 54	66	76	96	124	152	170	190	218
Clamp Torque	Nm 2.0	2.0	2.0	4.5	9	15.3	15.3	37	37
	In-lb 18	18	18	40	80	135	135	327	327
Torque Transmission	Nm 88	157	186	402	843	1450	2430	3312	5076
Capacity(bolt only)	In-lb 779	1389	1646	3558	7461	12833	21506	29311	44923

SHG Series Flexspline Installation

Table 20

Size	14	17	20	25	32	40	45	50	58	65
Number	8	12	12	12	12	12	18	12	16	16
Size	M3	M3	M3	M4	M5	M6	M6	M8	M8	M10
Pitch circle	mm 54	66	76	96	124	152	180	200	226	258
Clamp Torque	Nm 2.4	2.4	2.4	5.4	10.8	18.4	18.4	44	44	74
	In-lb 21	21	21	48	96	163	163	389	389	655
Torque Transmission	Nm 108	198	228	486	1000	1740	3098	4163	6272	9546
Capacity(bolt only)	In-lb 956	1752	2018	4301	8850	15399	27417	36843	55507	84482

Installation of the Circular Spline

SHF Series Bolt Installation

Table 21

Size	14	17	20	25	32	40	45	50	58
Number	6	12	12	12	12	12	12	12	12
Size	M3	M3	M3	M4	M5	M6	M8	M8	M10
Pitch circle	mm 44	54	62	75	100	120	140	150	175
Clamp Torque	Nm 2.0	2.0	2.0	4.5	9.0	15.3	37	37	74
	In-lb 18	18	18	40	80	135	327	327	655
Torque Transmission	Nm 54	131	147	314	676	1150	2440	2620	4820
Capacity(bolt only)	In-lb 478	1159	1301	2779	5983	10178	21594	23187	42657

SHG Series Bolt Installation

Table 22

Size	14	17	20	25	32	40	45	50	58	65
Number	8	16	16	16	16	16	16	16	16	16
Size	M3	M3	M3	M4	M5	M6	M8	M8	M10	M10
Pitch circle	mm 44	54	62	75	100	120	140	150	175	195
Clamp Torque	Nm 2.0	2.0	2.0	4.5	9	15.3	37	37	74	74
	In-lb 18	18	18	40	80	135	327	327	655	655
Torque Transmission	Nm 72	175	196	419	901	1530	3238	3469	6475	7215
Capacity(bolt only)	In-lb 637	1549	3708	7974	13541	28656	30701	57304	63853	565097

1. The material of the thread must withstand the clamp torque.
2. Recommended bolt : JIS B 1176 socket head cap screw strength range : JIS B 1051 over 12.9
3. Torque coefficient : K=0.2
4. Clamp coefficient A=1.4
5. Friction coefficient on the surface contacted: 0.15

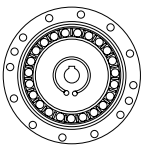

Assembly Order for Basic Three Elements

The recommended sequences of assembly are illustrated below. Only after the Circular Spline and Flexspline are assembled in equipment is the Wave Generator assembled. If assembly is performed using a different method, Dedoidal assembly or teeth breakage may occur. It is essential that teeth of the Flexspline and Circular Spline mesh symmetrically for proper function. An eccentric tooth mesh (Dedoidal), will result in noise and vibration and may lead to early failure of the gear.

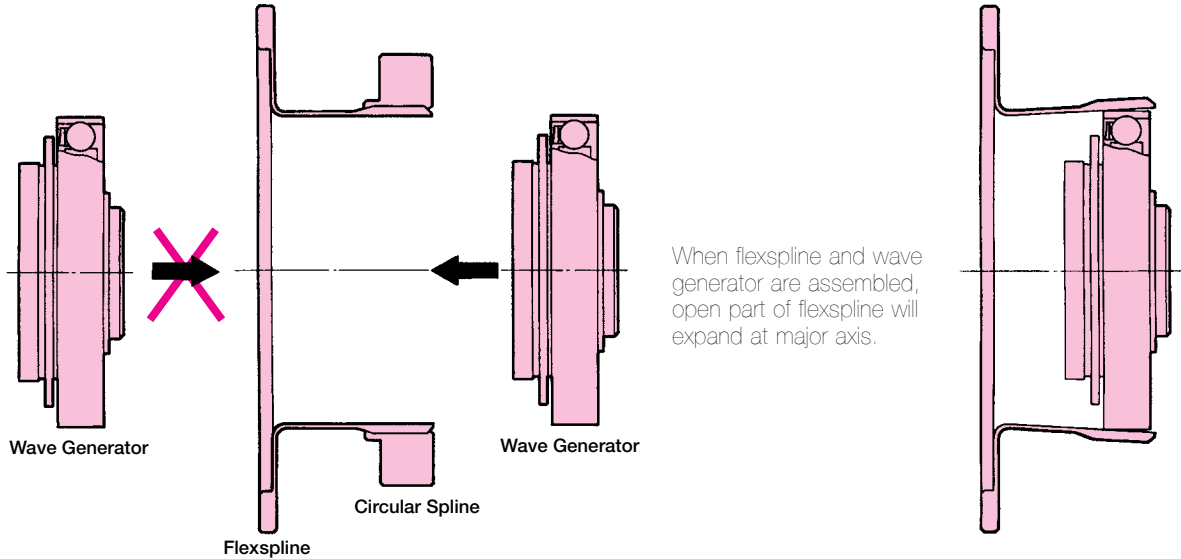

- Note:**
1. Avoid assembling with excessive force on Wave Generator bearing. Insert Wave Generator as you rotate it.
 2. If the Wave Generator does not have an Oldham coupling, special consideration must be given to ensure that concentricity and inclination are within the specified limits. (see page 12.)

Assembly procedure

Wave Generator

1. Avoid overloading the Wave Generator bearing during installation, rotate the Wave Generator as you easily install.
2. Since the Wave Generator does not have an Oldham coupling, make sure that the position is within the recommended tolerance shown on page 27.
3. Installation bolts on Wave Generator and installation bolt on Flexspline should not interfere each other.

Circular Spline

1. Be sure flatness and skewness are minimized.
2. Make sure there are no burrs or foreign substances.
3. Make sure there is enough room to have the minimum clearance in the housing.
4. Make sure that the Circular Spline rotates after installed in the housing.
5. When a bolt is inserted into a bolt hole, make sure that the bolt hole is located properly.
7. Bolts should not be tightened at the same time. Apply half of the recommended torque to tighten bolts, and then tighten bolts at the recommended torque. The order of tightening bolts should be done diagonally.

Avoid using pins to secure the Circular Spline if possible.

Flexspline

1. Be sure flatness and skewness are minimized.
2. Make sure there are no burrs or foreign substances.
3. Make sure there is enough room to have the minimum clearance in the housing.
4. When a bolt is inserted into a bolt hole, make sure that the bolt hole is located properly.
5. Bolts should not be tightened at the same time. Apply half of the recommended torque to tighten bolts, and then tighten bolts at recommended torque. The order of tightening bolts should be done diagonally.

Make sure that Circular Spline and Flexspline mesh properly.

Do not damage the Flexspline during assembly.

Note to prevent corrosion

The component type has not been treated for preventing corrosion. If needed, apply rust prevention on metal surfaces. As a special order, Harmonic Drive LLC can provide stainless steel components or surface treatments.

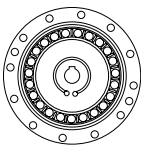

UNIT 2UH EXTERNAL DIMENSIONS

Hollow Type (2UH)

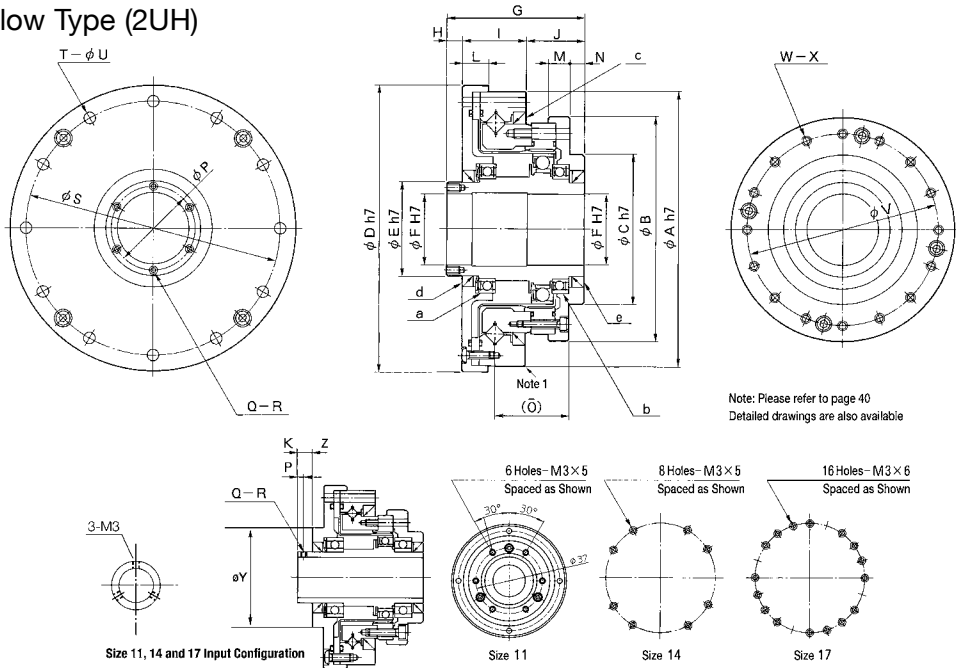

Note: Please refer to page 40
Detailed drawings are also available

SHF SHG 2UH Dimensions

Table 23 Unit: mm

	11	14	17	20	25	32	40	45	50	58	65
φAh7	62	70	80	90	110	142	170	190	214	240	276
φB	45.3	54	64	75	90	115	140	160	175	201	221
φCh7	30.5	36	45	50	60	85	100	120	130	150	160
φDh7	64	74	84	95	115	147	175	195	220	246	284
φEh7	18	20	25	30	38	45	59	64	74	84	96
φFh7	14	14	19	21	29	36	46	52	60	70	80
G	48	52.5	56.5	51.5	55.5	65.5	79	85	93	106	128
H	14	12	12	5	6	7	8	8	9	10	14
I	19	20.5	23	25	26	32	38	42	45	52	56.5
J	15	20	21.5	21.5	23.5	26.5	33	35	39	44	57.5
K	6.5	6.5	6.5	-	-	-	-	-	-	-	-
L	8	9	10	10.5	10.5	12	14	15	16	17	18
M ₁	6.5	8.5	9	8.5	9.5	13	12	12	15	19.5	
N	6.5	7.5	8.5	7	6	5	7	7	7	7	12
O	17.5	21.7	23.9	25.5	29.6	36.4	44	47.5	52.5	62.2	72
φP	3	2.5	2.5	25.5	33.5	40.5	52	58	67	77	88
Q	3	3	3	6	6	6	6	6	6	8	6
R	M3	M3	M3	M3x6	M3x6	M3x6	M4x8	M4x8	M4x8	M4x8	M5x10
φS	56.4	64	74	84	102	132	158	180	200	226	258
T	4	8	12	12	12	12	12	18	12	16	16
φU	3.5	3.5	3.5	3.5	4.5	5.5	6.6	6.6	9	9	11
φV	37	44	54	62	77	100	122	140	154	178	195
W	6	8/12 Note 1	16/20 Note 2	16	16	16	16	12	16	12	16
X	M3x5	M3x5 φ3.5x11.5	M3x6 φ3.5x12	M3x6 φ3.5x13.5	M4x7 φ4.5x15.5	M5x8 φ5.5x20.5	M6x10 φ6.6x25	M8x10 φ9x28	M8x11 φ9x30	M10x15 φ11x35	M10x15 φ11x42.5
φY	36	36	45	-	-	-	-	-	-	-	-
Z	7.5	5.5	5.5	-	-	-	-	-	-	-	-
a	6804ZZ	6804ZZ	6805ZZ	6806ZZ	6808ZZ	6809ZZ	6912ZZ	6913ZZ	6915ZZ	6917ZZ	6920ZZ
b	6704ZZ	6804ZZ	6805ZZ	6806ZZ	6808ZZ	6809ZZ	6812ZZ	6813ZZ	6815ZZ	6817ZZ	6820ZZ
c	D4195095	D49585	D59685	D69785	D84945	D1101226	D1321467	D1521707	D1681868	D1932129	D21623811
d	S18274	S20304.5	S25356	S30405	S38475	S45607	S60789	S658510	S759510	S8511012	S10012513
e	S18274	S20304.5	S25356	S30405	S38475	S45555	S59685	S59685	S69785	S84945	S961128
mass(kg)	0.53	0.71	1.00	1.38	2.1	4.5	7.7	10.0	14.5	20.0	28.5

Note 1 - 8 holes on an equally spaced 12 hole pattern.
Note 2 - 16 holes on an equally spaced 20 hole pattern.

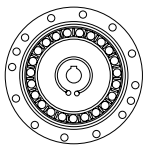

UNIT 2UJ EXTERNAL DIMENSIONS

Input Shaft Type (2UJ)

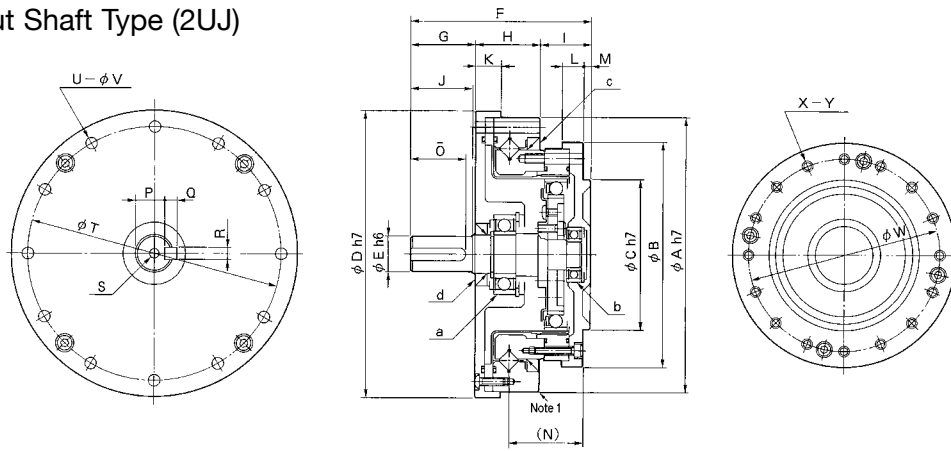

Note: Please refer to page 40
Detailed drawings are also available

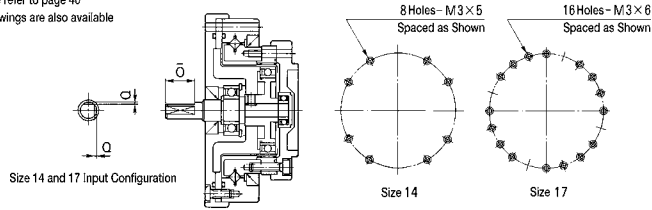

SHF SHG 2UJ Dimensions Table 24

Unit: mm

	14	17	20	25	32	40	45	50	58	65
øAh7	70	80	90	110	142	170	190	214	240	276
øB	54	64	75	90	115	140	160	175	201	221
øCh7	36	45	50	60	85	100	120	130	150	160
øDh7	74	84	95	115	147	175	195	220	246	284
øEh7	6	8	10	14	14	16	19	22	22	25
F	50.5	56	63.5	72.5	84.5	100	108	121	133	156
G	15	17	21	26	26	31	31	37	37	42
H	20.5	23	25	26	32	38	42	45	52	56.5
I	15	16	17.5	20.5	26.5	31	35	39	44	57.5
J	14	16	20	25	25	30	30	35	35	40
K	9	10	10.5	10.5	12	14	15	16	17	18
L	8	8.5	9	8.5	9.5	13	12	12	15	19.5
M ₁	2.5	3	3	3	5	5	7	7	7	12
N	21.7	23.9	25.5	29.6	36.4	44	47.5	52.5	62.2	72
O	11	12	16.5	22.5	22.5	27.5	28	33	33	39
P	-	-	8.2 ⁰ _{-0.1}	11 ⁰ _{-0.1}	11 ⁰ _{-0.1}	13 ⁰ _{-0.1}	15.5 ⁰ _{-0.1}	18.5 ⁰ _{-0.1}	18.5 ⁰ _{-0.1}	21 ⁰ _{-0.1}
Q	0.5	0.5	3 ⁰ _{-0.025}	5 ⁰ _{-0.030}	5 ⁰ _{-0.030}	5 ⁰ _{-0.030}	6 ⁰ _{-0.030}	6 ⁰ _{-0.030}	6 ⁰ _{-0.030}	7 ⁰ _{-0.036}
R	-	-	3 ⁰ _{-0.025}	5 ⁰ _{-0.030}	5 ⁰ _{-0.030}	5 ⁰ _{-0.030}	6 ⁰ _{-0.030}	6 ⁰ _{-0.030}	6 ⁰ _{-0.030}	8 ⁰ _{-0.036}
S	-	-	M3X6	M5X10	M5X10	M5X10	M6X12	M6X12	M6X12	M8X16
øT	64	74	84	102	132	158	180	200	226	258
U	8	12	12	12	12	12	18	12	16	16
øV	3.5	3.5	3.5	4.5	5.5	6.6	6.6	9	9	11
øW	44	54	62	77	100	122	140	154	178	195
X	12X8	20X16	16	16	16	16	12	16	12	16
øY	M3X5 ø3.5X11.5	M3X6 ø3.5X12	M3X6 ø3.5X13.5	M4X7 ø4.5X15.5	M5X8 ø5.5X20.5	M6X10 ø6.6X25	M8X10 ø9X28	M8X11 ø9X30	M10X15 ø11X35	M10X15 ø11X42.5
a	698 ZZ	6900 ZZ	6902 ZZ	6002 ZZ	6004 ZZ	6006 ZZ	6206 ZZ	6207 ZZ	6208 ZZ	6209 ZZ
b	695 ZZ	697 ZZ	698 ZZ	6900 ZZ	6902 ZZ	6003 ZZ	6004 ZZ	6005 ZZ	6006 ZZ	6007 ZZ
c	D49585	D59685	D69785	D84945	D1101226	D1321467	D1521707	D1681868	D1932129	D21623811
d	G8184	D10205	D15255	D15255	D20355	D30457	D30457	D35557	D40607	D45607
O ring	37.1X0.6	45.4X0.8	53.28X0.99	66.5X1.3	87.5X1.5	107.5X1.6	121.5X2.0	S135	157.0X2.0	S175
O ring	52.5X1.5	64.0X1.5	72.0X2.0	88.62X1.78	117.0X2.0	142.0X2.0	163.0X2.4	182.0X2.0	207.0X2.0	S235
mass(kg)	0.66	0.94	1.38	2.1	4.4	7.3	9.8	13.9	19.4	26.5

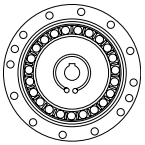

UNIT 2SO DIMENSIONS

Simple Unit Type (2SO)

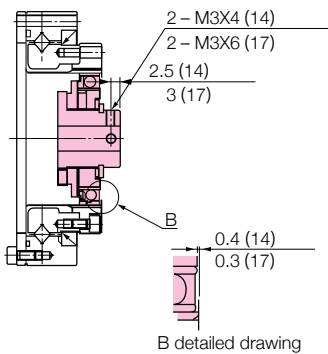
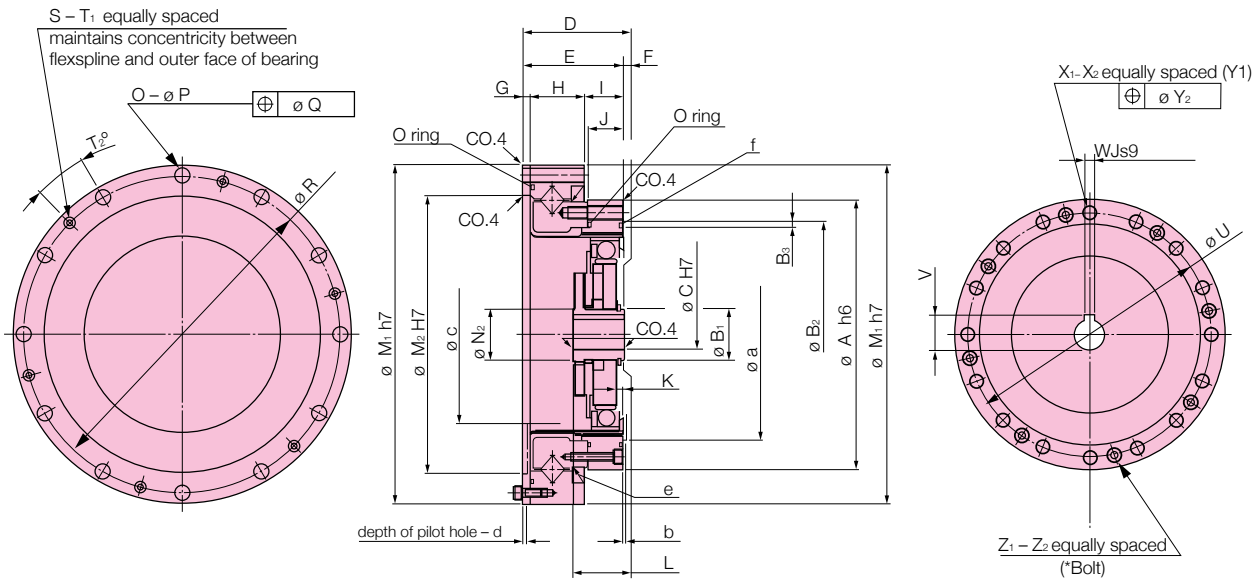

Size 14,17 Configuration of wave generator

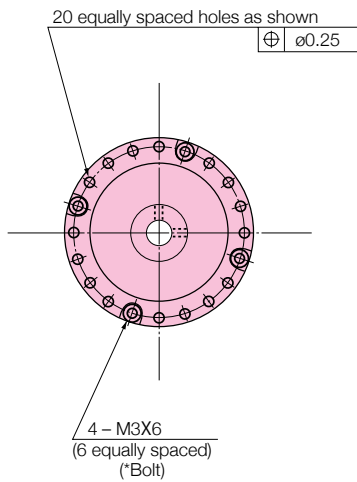

Size 17 configuration

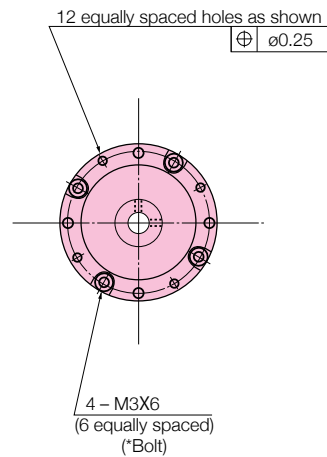

Size 14 configuration

*Bolt maintain assembly circular spline inner race of bearing

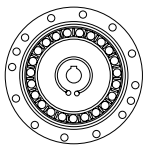

EXTERNAL DIMENSIONS

Table 25

(mm)

	14	17	20	25	32	40	45	50	58	65	
øA h6	50	60	70	85	110	135	155	170	195	215	
ø B ₁	14	18	21	26	26	32	32	32	40	48	
ø B ₂	–	–	–	–	–	–	128	141	163	180.4	
B ₃	–	–	–	–	–	–	2.7	2.7	2.7	2.7	
ø C	(H7) Standard	6	8	9	11	14	14	19	19	22	24
	Max.Dimension	8	10	13	15	15	20	20	20	25	30
D	SHF	28.5 ⁰ _{-0.8}	32.5 ⁰ _{-0.9}	33.5 ⁰ _{-1.0}	37 ⁰ _{-1.0}	44 ⁰ _{-1.1}	53 ⁰ _{-1.1}	58 ⁰ _{-1.2}	64 ⁰ _{-1.3}	75.5 ⁰ _{-1.3}	–
	SHG	28.5 ⁰ _{-0.4}	32.5 ⁰ _{-0.4}	33.5 ⁰ _{-0.4}	37 ⁰ _{-0.5}	44 ⁰ _{-0.6}	53 ⁰ _{-0.6}	58 ⁰ _{-0.6}	64 ⁰ _{-0.7}	75.5 ⁰ _{-0.7}	83 ⁰ _{-0.7}
E	23.5	26.5	29	34	42	51	56.5	63	73	81.5	
F	5	6	4.5	3	2	2	1.5	1	2.5	1.5	
G	2.4	3	3	3.3	3.6	4	4.5	5	5.8	6.5	
H	14.1	16	17.5	18.7	23.4	29	32	34	40.2	43	
I	7	7.5	8.5	12	15	18	20	24	27	32	
J	6	6.5	7.5	10	14	17	19	22	25	29	
K	SHF	0.4	0.3	0.1	2.1	2.5	3.3	3.7	4.2	4.8	–
	SHG	1.4	1.6	1.5	3.5	4.2	5.6	6.3	7	8.2	9.5
L	SHF	17.6 ⁰ _{-0.1}	19.5 ⁰ _{-0.1}	20.1 ⁰ _{-0.1}	20.2 ⁰ _{-0.1}	22 ⁰ _{-0.1}	27.5 ⁰ _{-0.1}	27.9 ⁰ _{-0.1}	32 ⁰ _{-0.1}	34.9 ⁰ _{-0.1}	–
	SHG	18.5 ⁰ _{-0.1}	20.7 ⁰ _{-0.1}	21.5 ⁰ _{-0.1}	21.6 ⁰ _{-0.1}	23.6 ⁰ _{-0.1}	29.7 ⁰ _{-0.1}	30.5 ⁰ _{-0.1}	34.8 ⁰ _{-0.1}	38.3 ⁰ _{-0.1}	44.6 ⁰ _{-0.1}
ø M ₁ h7	70	80	90	110	142	170	190	214	240	276	
ø M ₂ H7	48	60	70	88	114	140	158	175	203	232	
ø N ₂	–	–	–	–	–	32	–	32	–	48	
O	8	12	12	12	12	12	18	12	16	16	
ø P	3.5	3.5	3.5	4.5	5.5	6.6	6.6	9	9	11	
ø Q	0.25	0.25	0.25	0.25	0.25	0.3	0.3	0.5	0.5	0.5	
ø R	64	74	84	102	132	158	180	200	226	258	
S	2	4	4	4	4	6	6	6	8	8	
T ₁	M3X6	M3X6	M3X8	M3X8	M4X8	M4X10	M4X8	M5X12	M5X12	M6X16	
T ₂ Angle	22.5°	15°	15°	15°	15°	15°	10°	15°	11.25°	11.25°	
ø U	44	54	62	77	100	122	140	154	178	195	
V	–	–	10.4 ^{+0.1}	12.8 ^{+0.1}	16.3 ^{+0.1}	16.3 ^{+0.1}	21.8 ^{+0.1}	21.8 ^{+0.1}	24.8 ^{+0.1}	27.3 ^{+0.2}	
W Js9	–	–	3	4	5	5	6	6	6	8	
X ₁	12/8	20/16	16	16	16	16	12	16	12	16	
X ₂	M3X5	M3X6	M3X6	M4X7	M5X8	M6X10	M8X10	M8X11	M10X15	M10X15	
Y ₁	ø 3.5X6	ø 3.5X6.5	ø 3.5X7.5	ø 4.5X10	ø 5.5X14	ø 6.6X17	ø 9X19	ø 9X22	ø 11X25	ø 11X29	
Y ₂	0.25	0.25	0.25	0.25	0.25	0.3	0.5	0.5	0.5	0.5	
Z ₁	4	4	4	4	4	4	4	8	6	8	
Z ₂	M3X6	M3X6	M3X8	M3X10	M4X16	M5X20	M5X20	M5X20	M6X25	M6X30	
ø a	38	45	53	66	86	106	119	133	154	172	
b	1	1	1.5	1.5	1.5	2	2	2	2.5	2.5	
ø c	31	38	45	56	73	90	101	113	131	150	
d	1.7	2.1	2	2	2	2	2.3	2.5	2.9	3.5	
e	D49585	D59685	D69785	D84945	D1101226	D1321467	D1521707	D1681868	D1932129	D21623811	
f	–	–	–	–	–	–	d1 121.5 d2 2.0	S135	d1 157.0 d2 2.0	S175	
Weight (kg)	0.41	0.57	0.81	1.31	2.94	5.1	6.5	9.6	13.5	19.5	

Unit Type

- Installed surface on Circular Spline is shown as (A). Use this surface for installation in case.
- Dimensions shown below maybe modified as a special order.

Wave Generator : V
 Flexspline : L and M
 Circular Spline : R and S

- Dimensions for B, C₁, C₂ must meet the tolerance values shown above.
- Due to the deformation of the Flexspline during operation, it is necessary to provide a minimum housing clearance. (Dimensions ø a to e)

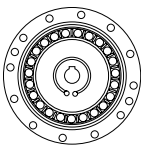

UNIT 2SH DIMENSIONS

Simple Unit Type (2SH)

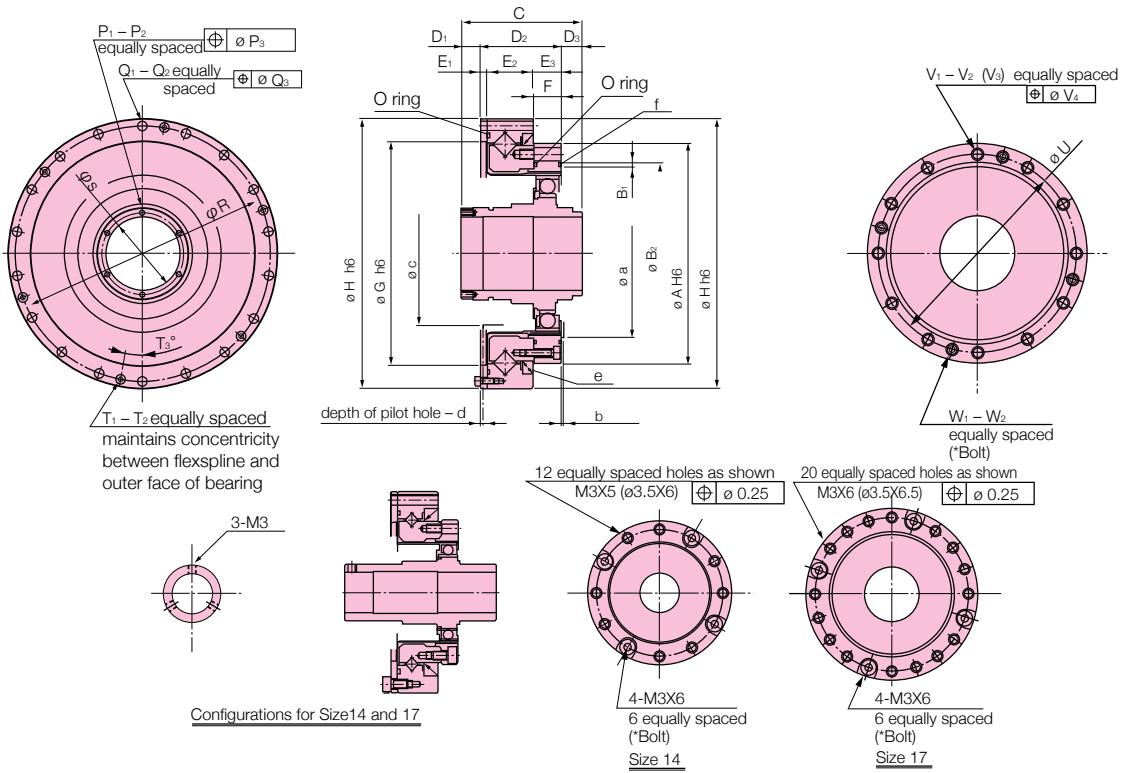

Configurations Of Wave Generator All Sizes

Size 14 & 17

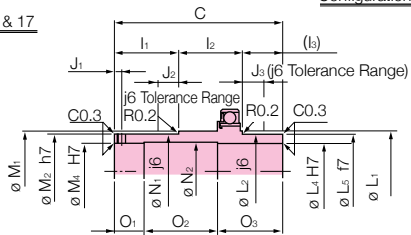

Size 20

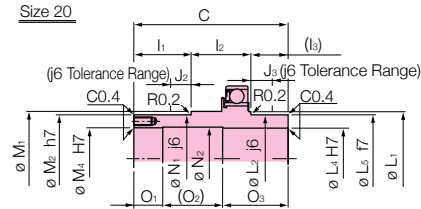

Size 25

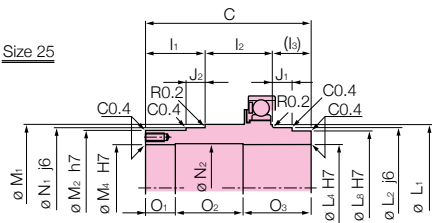

Size 32

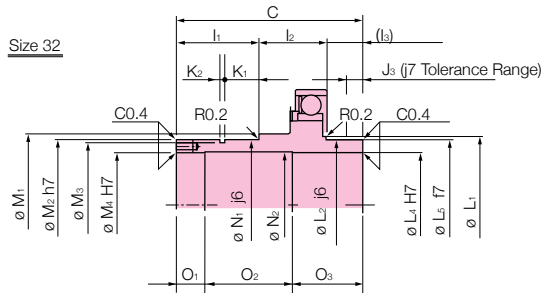

Size 40-65

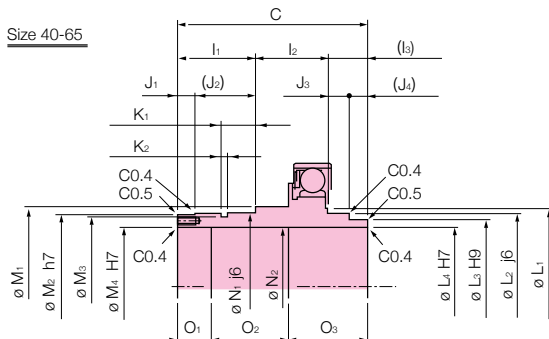

*Bolt maintain assembly circular spline inner race of bearing

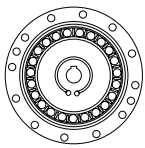

EXTERNAL DIMENSIONS

Table 26

(mm)

	14	17	20	25	32	40	45	50	58	65
ø A h6	50	60	70	85	110	135	155	170	195	215
ø B ₁	-	-	-	-	-	-	128	141	163	180.4
B ₂	-	-	-	-	-	-	2.7	2.7	2.7	2.7
C	52.5 ⁰ _{-0.1}	56.5 ⁰ _{-0.1}	51.5 ⁰ _{-0.1}	55.5 ⁰ _{-0.1}	65.5 ⁰ _{-0.1}	79 ⁰ _{-0.1}	85 ⁰ _{-0.1}	93 ⁰ _{-0.1}	106 ⁰ _{-0.1}	128 ⁰ _{-0.1}
D ₁	16	16	9.5	10	12	13	13.5	15	16	21
D ₂	23.5	26.5	29	34	42	51	56.5	63	73	81.5
D ₃	13	14	13	11.5	11.5	15	15	15	17	25.5
E ₁	2.4	3	3	3.3	3.6	4	4.5	5	5.8	6.5
E ₂	14.1	16	17.5	18.7	23.4	29	32	34	40.2	43
E ₃	7	7.5	8.5	12	15	18	20	24	27	32
F	6	6.5	7.5	10	14	17	19	22	25	29
ø G H6	48	60	70	88	114	140	158	175	203	232
ø H h6	70	80	90	110	142	170	190	214	240	276
I ₁	20 _{±0.1}	21.5 _{±0.1}	19 _{±0.1}	20 _{±0.1}	29 _{±0.1}	34 _{±0.1}	35 _{±0.1}	39.5 _{±0.1}	45.3 _{±0.1}	54.5 _{±0.1}
I ₂ SHF	20 _{±0.1}	21.5 _{±0.1}	20 _{±0.1}	22.5 _{±0.1}	23.5 _{±0.1}	28 _{±0.1}	32.5 _{±0.1}	36 _{±0.1}	40.7 _{±0.1}	-
SHG	□	□	□	23 _{±0.1}	□	28.5 _{±0.1}	□	□	□	50.5 _{±0.1}
I ₃ SHF	(12.5)	(13.5)	(12.5)	(13)	(13)	(17)	(17.5)	(17.5)	(20)	-
SHG	□	□	□	(12.5)	□	(16.5)	□	□	□	(23)
J ₁	2.5	2.5	-	-	-	-	8	9	10	14
J ₂	7	7	7	6.5	-	-	(27)	(30.5)	(35.3)	(40.5)
J ₃	7	7	7	6.5	-	9.5	9.5	9.5	12.5	11.5
J ₄	-	-	-	-	-	(7.5)	(8)	(8)	(7.5)	(11.5)
K ₁	-	-	-	-	13.9	15.1	15.6	18.6	21.1	23.1
K ₂	-	-	-	-	1.9	2.2	2.7	2.7	3.2	3.1
ø L ₁	22	27	32	42	47	62	69	79	90	106
ø L ₂ j6	20	25	30	40	45	60	65	75	85	100
ø L ₃ h9	-	-	-	38	-	59	59	69	84	96
ø L ₄ H7	14	19	21	29	36	46	52	60	70	80
ø L ₅ f7	20	25	30	-	45	-	-	-	-	-
ø M ₁	22	27	32	42	49	65	70	80	91.5	111
ø M ₂ h7	20	25	30	38	45	59	64	74	84	96
ø M ₃	-	-	-	-	42.5	57	62	72	81.5	96.5
ø M ₄ H7	14	19	21	29	36	46	52	60	70	80
ø N ₁ j6	20	25	30	40	45	60	65	75	85	100
ø N ₂	14.5	19.5	21.5	29.5	36.5	46.5	52.5	60.5	70.5	80.5
O ₁	10	10	10	10	10	12	15	15	15	20
O ₂	22.5	24.5	(19.5)	22.5	(30.5)	(35)	35	41	48	54
O ₃	20	22	22	23	25	32	35	37	43	54
P ₁	3	3	6	6	6	6	6	6	8	6
P ₂	M3	M3	M3X6	M3X6	M3X6	M4X8	M4X8	M4X8	M4X8	M5X10
ø P ₃	-	-	0.25	0.25	0.25	0.25	0.25	0.25	0.25	0.25
Q ₁	8	12	12	12	12	12	18	12	16	16
ø Q ₂	3.5	3.5	3.5	4.5	5.5	6.6	6.6	9	9	11
ø Q ₃	0.25	0.25	0.25	0.25	0.25	0.3	0.3	0.5	0.5	0.5
ø R	64	74	84	102	132	158	180	200	226	258
ø S	-	-	25.5	33.5	40.5	52	58	67	77	88
T ₁	2	4	4	4	4	6	6	6	8	8
T ₂	M3X6	M3X6	M3X8	M3X8	M4X8	M4X10	M4X10	M5X12	M5X12	M6X16
T ₃ Angle	22.5°	15°	15°	15°	15°	15°	10°	15°	11.25°	11.25°
ø U	44	54	62	77	100	122	140	154	178	195
V ₁	12/8	20/16	16	16	16	16	12	16	12	16
V ₂	M3X5	M3X6	M3X6	M4X7	M5X8	M6X10	M8X10	M8X11	M10X15	M10X15
V ₃	ø 3.5X6	ø 3.5X6.5	ø 3.5X7.5	ø 4.5X10	ø 5.5X14	ø 6.6X17	ø 9X19	ø 9X22	ø 11X25	ø 11X29
V ₄	0.25	0.25	0.25	0.25	0.25	0.3	0.5	0.5	0.5	0.5
W ₁	4	4	4	4	4	4	4	8	6	8
W ₂	M3X6	M3X6	M3X8	M3X10	M4X16	M5X20	M5X20	M5X25	M6X25	M6X30
Inner Case										
ø a	38	45	53	66	86	106	119	133	154	172
b	1	1	1.5	1.5	1.5	2	2	2	2.5	2.5
ø c	31	38	45	56	73	90	101	113	131	150
d	1.7	2.1	2	2	2	2	2.3	2.5	2.9	3.5
e	D49585	D59685	D69785	D84945	D1101226	D1321467	D1521707	D1681868	D1932129	D21623811
f	-	-	-	-	-	-	d1 121.5 d2 20	S135	d1 157.0 d2 20	S175
Weight (kg)	0.45	0.63	0.89	1.44	3.1	5.4	6.9	10.2	14.1	20.9

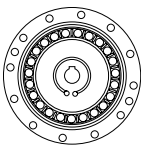

SPECIFICATIONS FOR CROSS ROLLER BEARING

Specification for Cross Roller Bearing

Housed units incorporate a precise cross roller bearing to directly support a load. The inner race of the bearing forms the output flange.

Please calculate maximum load moment, life of cross roller bearing, and static safety factor to fully maximize the performance of housed unit (gearhead).

Calculation Procedure

1. Maximum Load Moment (Mmax)



2. Output Bearing Life



3. Static Safety Factor



Specification for cross roller bearing

Specification for cross roller bearing is shown on figure.

Table 27

Size	Pitch Circle dp m	Offset R m	Basic Dynamic Rated Load C		Basic Static Rated Load C ₀		Allowable Moment Load M _c		Moment Rigidity Km x10 ⁴	
			X10 ² N	lb	X10 ² N	lb	Nm	in-lb	Nm/rad	in-lb/ arc-min
11	0.043	0.0180	52.9	1189	75.5	1697	74	655	6.5	167
14	0.050	0.0217	58	1304	86	1933	74	655	8.5	219
17	0.060	0.0239	104	2338	163	3664	124	1097	15.4	397
20	0.070	0.0255	146	3282	220	4946	187	1655	25.2	649
25	0.085	0.0296	218	4901	358	8048	258	2283	39.2	1009
32	0.111	0.0364	382	8587	654	14702	580	5133	100	2575
40	0.133	0.0440	433	9734	816	18344	849	7514	179	4609
45	0.154	0.0475	776	17444	1350	30348	1127	9974	257	6618
50	0.170	0.0525	816	18344	1490	33495	1487	13160	351	9038
58	0.195	0.0622	874	19648	1710	38441	2180	19293	531	13673
65	0.218	0.0720	1300	29224	2230	50130	2740	24249	741	19081

Basic dynamic rated load is a constant radial load where the basic dynamic rated life of CRB is 1×10^6 rotations.

Basic static rated load is a static load where the value of moment rigidity is the average value.

For the following size and gear ratio combinations, the life of the cross roller bearing operating at the allowable moment load is less than the life of the wave generator bearing ($L_{10} = 7000$ hr) operating at 2000rpm and rated torque.

Table 28

Size	Gear Ratio		
14	50	80	100
17	50	80	
20	50		

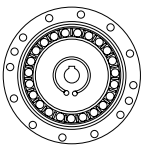

OUTPUT BEARING RATING

How to Calculate the Maximum Load Moment

How to calculate the Maximum load moment is shown below. Please be sure that M_c is equal or greater than M_{max} .

$$M_{max} = F_{rmax} \cdot (L_r + R) + F_{amax} \cdot L_a \quad \text{equation (1)}$$

F_{rmax}	Max. radial load	N	Figure 8
F_{amax}	Max. axial load	N	Figure 8
L_r, L_a	Moment arm	m	Figure 7
R	amount of offset	m	Table 34

How to Calculate an Average Load

To calculate average radial load, average axial load or average output speed, follow steps below.

When the radial load and axial load vary, the life of cross roller bearing can be determined by converting to an average load. (see figure 8)

equation (2) Calculate Average Radial Load

$$F_{rav} = \sqrt[10/3]{\frac{n_1 t_1 |F_{r1}|^{10/3} + n_2 t_2 |F_{r2}|^{10/3} \dots + n_n t_n |F_{rn}|^{10/3}}{n_1 t_1 + n_2 t_2 \dots + n_n t_n}}$$

However Max. radial load in t_1 is F_{r1} , Max. radial load in t_3 is F_{r3} .

equation (3) Calculate Average Axial Load (F_{aav})

$$F_{aav} = \sqrt[10/3]{\frac{n_1 t_1 |F_{a1}|^{10/3} + n_2 t_2 |F_{a2}|^{10/3} \dots + n_n t_n |F_{an}|^{10/3}}{n_1 t_1 + n_2 t_2 \dots + n_n t_n}}$$

However, an axial load in t_1 is F_{a1} , Max. axial load in t_3 is F_{a3} .

equation (4) Calculate Average Output Speed

$$N_{av} = \frac{n_1 t_1 + n_2 t_2 \dots + n_n t_n}{t_1 t_2 \dots + t_n}$$

equation (5)

How to calculate radial load coefficient (X) axial load (Y) list 2

	X	Y
$\frac{F_{aav}}{F_{rav+2} (F_{rav} (L_r + R) + F_{aav} \cdot L_a) / dp}$	≤ 1.5	1 0.45
$\frac{F_{aav}}{F_{rav+2} (F_{rav} (L_r + R) + F_{aav} \cdot L_a) / dp}$	> 1.5	0.67 0.67

F_{rmax}	Max. radial load	N	Figure 8
F_{amax}	Max. axial load	N	Figure 8
L_r, L_a	Moment arm	m	Figure 7
R	amount of offset	m	Table 34
dp	pitch circle	m	Table 34

Figure 7

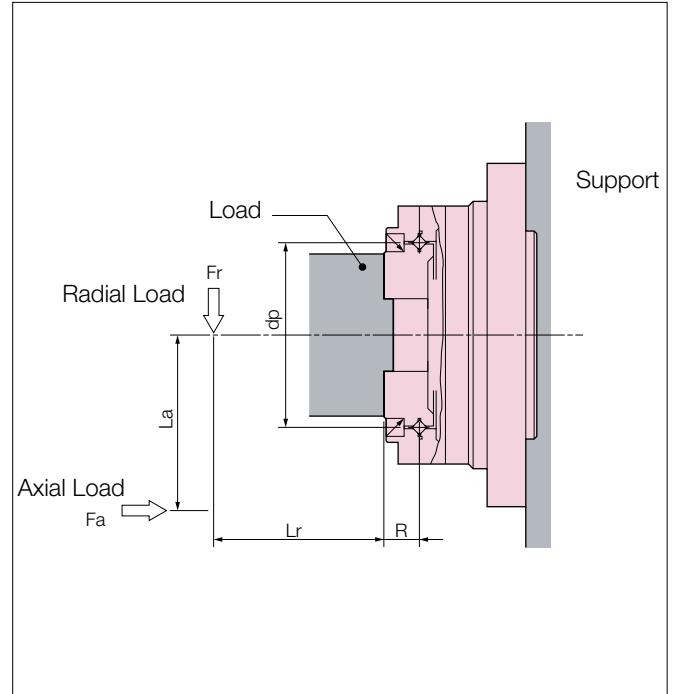
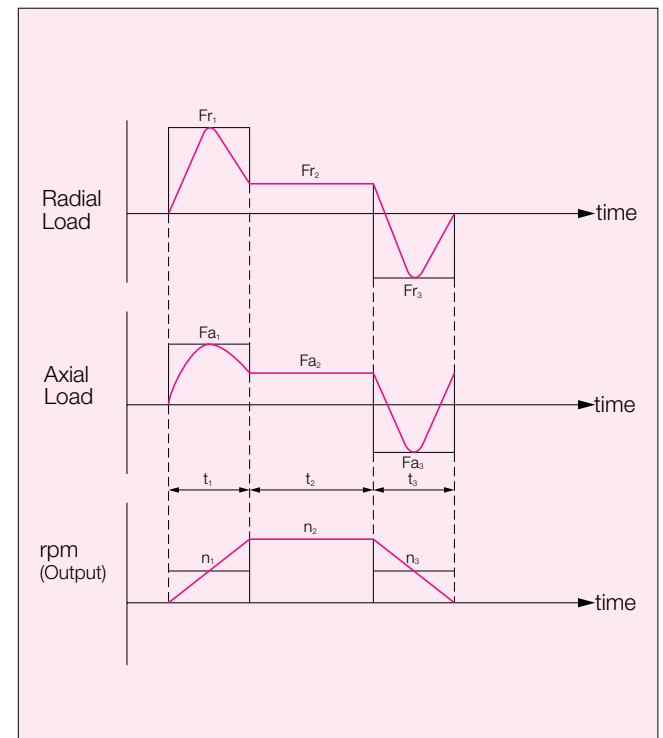
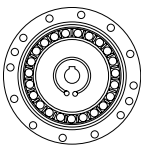

Figure 8





OUTPUT BEARING LIFE

How to Calculate Life of the Output Bearing

The life of a cross roller bearing can be calculated by equation (6).

equation (6)

$$L_{10} = \frac{10^6}{60 \times n_{av}} \times \left(\frac{C}{f_w \cdot P_c} \right)^{10/3}$$

L ₁₀	Life	Hour	-----
n _{av}	Average Output Speed	rpm	equation 14
C	Basic Dynamic Rated Load	N	table 30
P _c	Dynamic Equivalent	N	equation 15
f _w	Load Coefficient	-----	list 3

List 3

Load Coefficient, f_w

Steady operation without impact and vibration	1~1.2
Normal operation	1.2~1.5
Operation with impact and vibration	1.5~3

Dynamic Equivalent Radial Load

equation 70

$$P_c = X \cdot \left(\frac{2 (F_{rav} (L_r + R) + F_{aav} \cdot L_a)}{d_p} \right) + Y \cdot F_{aav}$$

Symbol of equation

F _{rav}	Average radial load	N	equation 10
F _{aav}	Average axial load	N	equation 11
d _p	Pitch diameter	m	table 29
X	Radial load coefficient	-----	list 2
Y	Axial load coefficient	-----	list 2
L _r , L _a	Moment Arm	m	figure 6
R	Offset	m	figure 5 and table 29

How to Calculate Static Safety Coefficient

Basic static rated load is an allowable limit for static load, but its limit is determined by usage. In this case, static safety coefficient of the cross roller bearing can be calculated by equation 8.

Reference values under general conditions are shown on list 4.

Static equivalent radial load can be calculated by equation (8)

equation (8)

$$f_s = \frac{C_0}{P_0}$$

Symbols for equation (17)

C ₀	Basic static rated load	N	table 29
P ₀	Static equivalent radial load	N	refer to equation (18)

Rotating Conditions	Load Conditions	Lower Limit Value for f _s
Normally not rotating	Slight oscillations Impact loads	0.5 1-1.5
Normally rotating	Normal loads Impact loads	1-2 2-3

How to Calculate Life for Oscillating Motion

The Life of a cross roller bearing in a oscillating operation can be calculated by equation 10

equation (9)

$$L_{oc} = \frac{10^6}{60 \times n_1} \times \frac{90}{\emptyset} \times \left(\frac{C}{f_w \cdot P_c} \right)^{10/3}$$

Symbol of equation

L _{oc}	Rated life for oscillating motion	Hour	-----
n ₁	Round trip oscillation each minute	rpm	-----
C	Basic dynamic rated load	N	-----
P _c	Dynamic equivalent radial load	N	equation
f _w	Load Coefficient	-----	list 3
∅	Angle of oscillation/2	degrees refer to figure	

figure 9

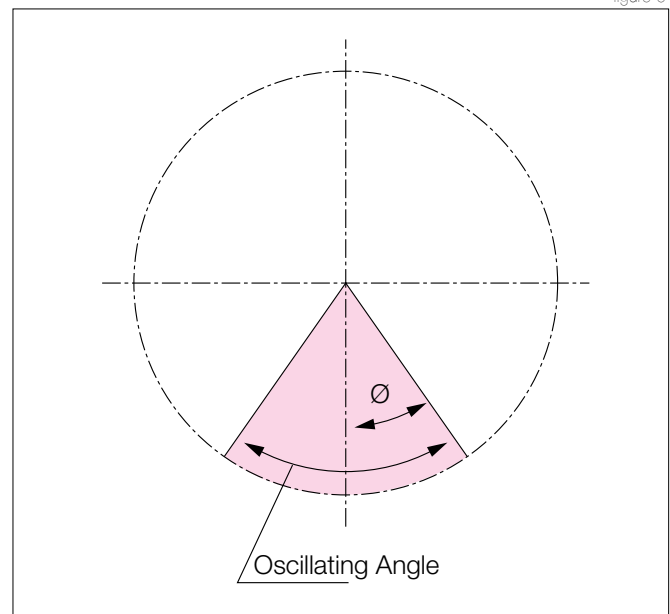

A small angle of oscillation (less than 5 degrees) may cause fretting corrosion to occur since lubrication may not circulate properly.

equation (10)

$$P_0 = F_{rmax} + \frac{2M_{max}}{d_p} + 0.44 \cdot F_{amax}$$

Symbols for Equation		
F _{rmax}	Max. radial load	N
F _{amax}	Max. axial load	N
M _{max}	Max. moment load	Nm
d _p	Pitch diameter	m

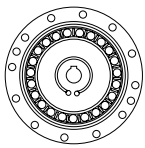

RECOMMENDED TOLERANCES FOR ASSEMBLY

Unit types

Recommended Tolerances for Assembly

For peak performance of the SHF/SHG Unit type it is essential that the following tolerances be observed when assembly is complete.

Recommended tolerances for assembly.

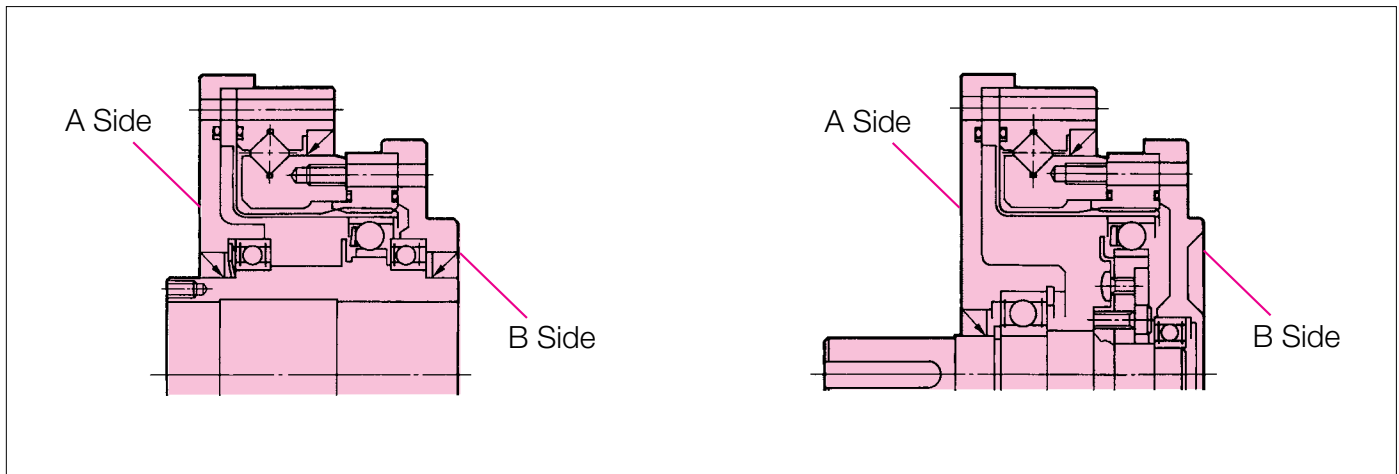

SHF Series (A) Side-installation and Torque Transmission Capacity

Table 29

Size	11	14	17	20	25	32	40	45	50	58
Number	4	8	12	12	12	12	12	18	12	16
Size	M3	M3	M3	M3	M4	M5	M6	M6	M8	M8
Pitch circle	mm 56.4	64	74	84	102	132	158	180	200	226
Clamp Torque	Nm 2.0	2.0	2.0	2.0	4.5	9.0	15.3	15.3	37	37
	In-lb 18	18	18	18	40	80	135	135	327	327
Torque Transmission	Nm 47	108	186	206	431	892	1509	2578	3489	5236
Capacity(bolt only)	In-lb 416	956	1646	1823	3814	7894	13355	22815	30878	46578

SHG Series (A) Side-installation and Torque Transmission Capacity

Table 30

Size	14	17	20	25	32	40	45	50	58	65
Number	8	12	12	12	12	12	18	12	16	16
Size	M3	M3	M3	M4	M5	M6	M6	M8	M8	M10
Pitch circle	mm 64	74	84	102	132	158	180	200	226	258
Clamp Torque	Nm 2.4	2.4	2.4	5.4	10.8	18.4	18.4	44	44	74
	In-lb 21	21	21	48	96	163	163	389	389	655
Torque Transmission	Nm 128	222	252	516	1069	1813	3098	4163	6272	9546
Capacity(bolt only)	In-lb 1133	1965	4567	9461	16045	27417	36843	55507	84482	74767

1. The material of the thread must withstand the clamp torque.
2. Recommended bolt : JIS B 1176 socket head cap screw strength range : JIS B 1051 over 12.9
3. Torque coefficient : K=0.2
4. Clamp coefficient A=1.4
5. Friction coefficient on the surface contacted: 0.15
6. Dowel Pin: parallel pin Material:S45C-Q Shear stress:~+30kgf/m

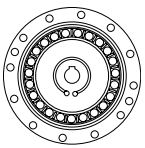

RECOMMENDED TOLERANCES FOR ASSEMBLY

SHF Series (B) Side-installation and Torque Transmission Capacity

Table 31

Size	11	14	17	20	25	32	40	45	50	58
Number	6	8	16	16	16	16	16	12	16	12
Size	M3	M3	M3	M3	M4	M5	M6	M8	M8	M10
Pitch circle	mm 37	44	54	62	77	100	122	140	154	178
Clamp Torque	Nm 2.0	2.0	2.0	2.0	4.5	9.0	15.3	37	37	74
	In-lb 18	18	18	18	40	80	135	327	327	655
Torque Transmission	Nm 46	72	176	206	431	902	1558	2440	3587	4910
Capacity(bolt only)	In-lb 407	637	1558	1823	3814	7983	13788	21594	31745	43454

SHG Series (B) Side-installation and Torque Transmission Capacity

Table 32

Size	14	17	20	25	32	40	45	50	58	65
Number	8	16	16	16	16	16	12	16	12	16
Size	M3	M3	M3	M4	M5	M6	M8	M8	M10	M10
Pitch circle	mm 44	54	62	77	100	122	140	154	178	195
Clamp Torque	Nm 2.4	2.4	2.4	5.4	10.8	18.4	44	44	89	89
	In-lb 21	21	21	48	96	163	389	389	788	788
Torque Transmission	Nm 88	216	248	520	1080	1867	2941	4274	5927	8658
Capacity(bolt only)	In-lb 779	1912	4602	9558	16523	26028	37825	52454	76623	678116

- The material of the thread must withstand the clamp torque.
- Recommended bolt : JIS B 1176 socket head cap screw strength range : JIS B 1051 over 12.9
- Torque coefficient : $K=0.2$
- Clamp coefficient $A=1.4$
- Friction coefficient on the surface contacted: 0.156. Dowel Pin: parallel pin Material:S45C-Q Shear stress: $+30\text{kgf/m}$

Output for Unit Type

Output flange for Unit type varies depending on which flange is fixed.

Gear ratio and rotation also vary. See page 6.

Fixed	Output	Ratio & Rotation
A	B	2 on Page 6
B	A	1 on Page 6

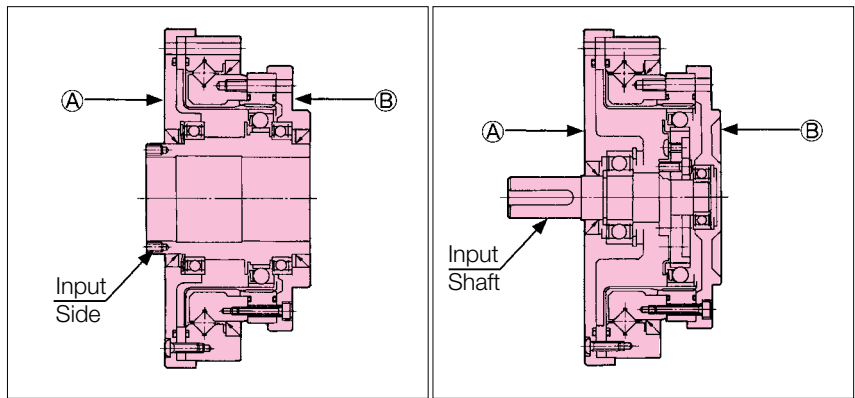

Continuous Operation of Hollow Shaft Type-2UH

The friction of the rotary shaft seals at the input side can result in an increased temperature of the SHF-2UH units during operation. For continuous operation at Rated speed, the Max. Operating Times specified in Table 33 should not be exceeded.

Continuous Operating Time

Table 33

Size	Operating time at No load (min)	Operating time at Rated Torque (min)
14	90	60
17	90	60
20	90	60
25	60	45
32	45	35
40	40	30
45	35	25
50	30	20
58	20	15
65	15	10

Note: Above Continuous Operating Time will be change depending on operating condition. Please contact us.

Note to Prevent Corrosion: The unit type has not been treated for preventing corrosion except cross roller bearing. If needed, apply rust prevention on metal surfaces. As a special order, Harmonic Drive LLC can provide stainless steel components or surface treatments.

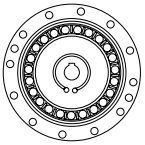

Lubrication

The standard lubrication for the SHF/SHG gear is Harmonic Grease SK – 1A and SK-2.
(Harmonic Grease 4B No.2 is used for cross roller bearing.)
Please see page 18 for grease specification.

Seal Structure

A seal structure is needed to maintain the high durability of the gear and prevent grease leakag

Key Points to Verify

- Rotating parts should have an oil seal (with spring)
- Surface should be smooth (no scratches)
- Mating flange should have an O Ring, seal adhesive
- Screws should have a thread lock (Loctite 242 recommended) or seal adhesive

Note:

- If you use Harmonic Grease 4Bno.2, strict sealing is required

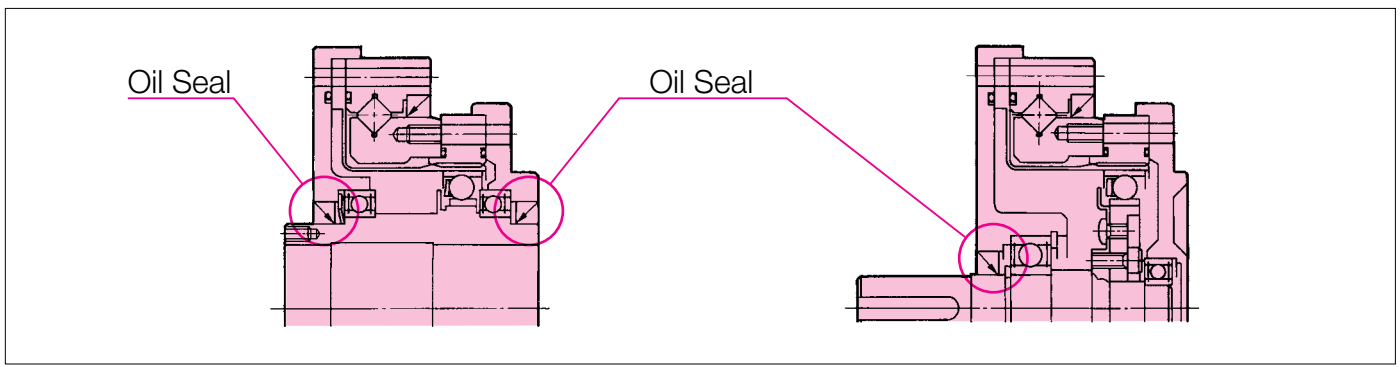

Manufacturing for Mating Part and Housing

When the housing interferes with corner "A" shown in Fig(.), an undercut in the housing is recommended as shown in Fig..(.).

HOLLOW TYPE (2UH)

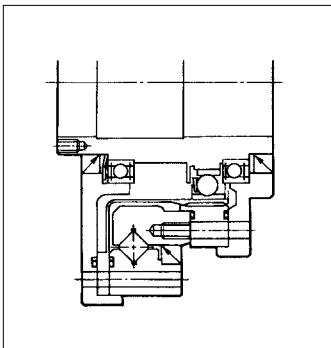

INPUT SHAFT TYPE (2UJ)

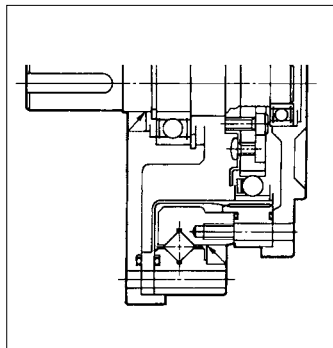

SIMPLE UNIT (2SO)

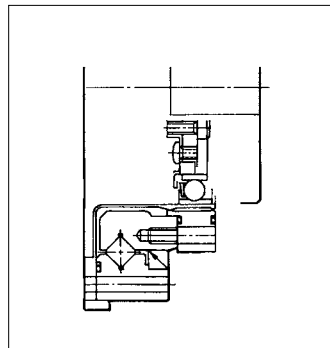

SIMPLE UNIT (2SH)

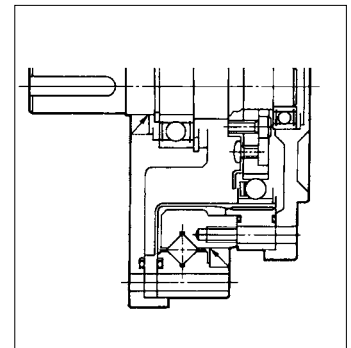

Recommended Housing Undercut

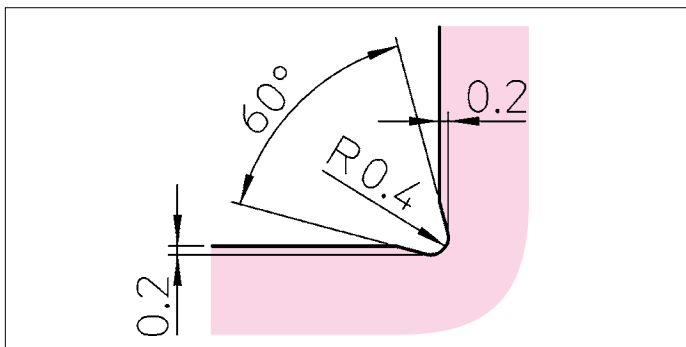

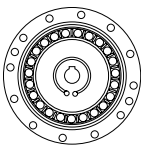

Performance Data for the Input Bearing The Hollow Shaft Type (2UH)

The Hollow Shaft incorporated in the SHF-2UH unit is supported by two deep groove single row ball bearings. For peak performance of the SHF-2UH it is essential that the following Specification for Input Bearing be observed the input loads. Fig. 1 shows the points of application of forces, which determine the Maximum Allowable Radial and Axial Loads as indicated in Fig. 2 & 3. The maximum values, as given Figures 2 and 3, are valid for an average input speed of 2,000 rpm and a mean bearing life of $L_{10}=7,000h$. Example: If the hollow shaft of a SHF-40-2UH unit is subjected to an axial load of 500 N. The maximum allowable radial force will be 400 N, Fig.3.

Size	Model	Bearing A				Bearing B				b		Max Radial Load		
		Basic Dynamic Rated Load		Basic Static Rated Load		Model	Basic Dynamic Rated Load		Basic Static Load		mm	mm	Fr	
		Cr	Cr	Cr	Cr		N	lb	N	lb			N	lb
		N	lb	N	lb		N	lb	N	lb			N	lb
11	6704ZZ	4000	899	2470	555	6704ZZ	1400	315	720	162	25.7	15.5	240	54
14	6804ZZ	4000	899	2470	555	6804ZZ	4000	899	2470	555	27	16.5	230	52
17	6805ZZ	4300	967	2950	663	6805ZZ	4300	967	2950	663	29	17.5	250	56
20	6806ZZ	4500	1012	3450	776	6806ZZ	4500	1012	3450	776	27	15.5	275	62
25	6808ZZ	4900	1102	4350	978	6808ZZ	4900	1102	4350	978	29.5	16.5	250	56
32	6909ZZ	14100	3170	10900	2450	6809ZZ	5350	1203	5250	1180	33	23	770	173
40	6912ZZ	19400	4361	16300	3664	6812ZZ	11500	2585	10900	2450	39.5	27.5	1060	238
45	6913ZZ	17400	3912	16100	3619	6813ZZ	11900	2675	12100	2720	44	28.5	900	202
50	6915ZZ	24400	5485	22600	5080	6815ZZ	12500	2810	13900	3125	49	31.5	1370	308
58	6917ZZ	32000	7194	29600	6654	6817ZZ	18700	4204	2000	4496	56.2	36.5	1720	387
65	6920ZZ	42500	9554	36500	8205	6820ZZ	19600	4406	21200	4766	67	44.5	2300	517

Table 34

figure 1

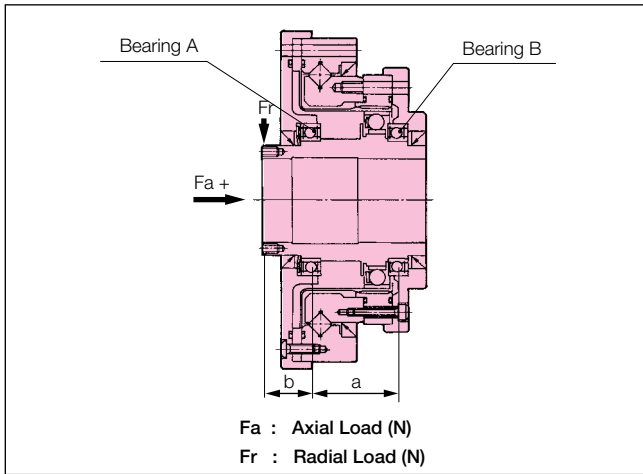

figure 2

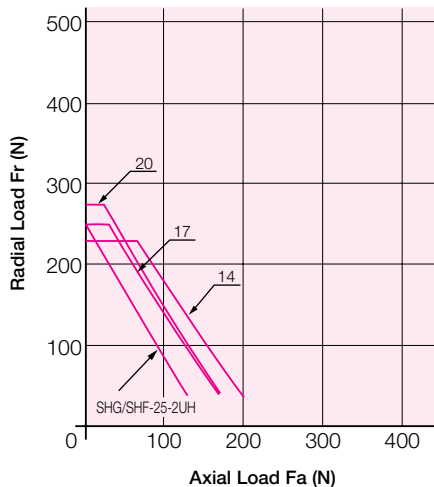
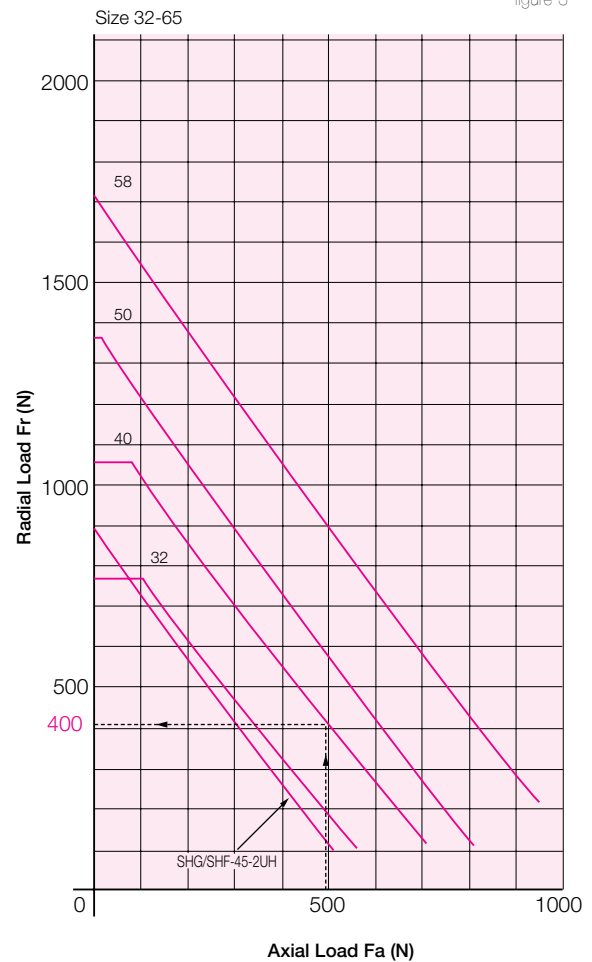
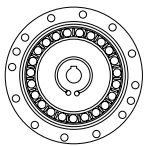

figure 3





Performance Data for the Input Bearing The Hollow Shaft Type (2UJ)

The Hollow Shaft incorporated in the SHF-2UH unit is supported by two deep groove single row ball bearings. For peak performance of the SHF-2UJ it is essential that the following Specification for Input Bearing be observed the input loads. Fig. 1 shows the points of application of forces, which determine the Maximum Allowable Radial and Axial Loads as indicated in Fig. 2 & 3. The maximum values, as given Figures 2 and 3, are valid for an average input speed of 2,000 rpm and a mean bearing life of $L_{10}=7,000h$. Example: If the hollow shaft of a SHF-45-2UJ unit is subjected to an axial load of 500 N. The maximum allowable radial force will be 400 N, Fig.3.

Size	Model	Bearing A				Bearing B				b		Max radial Load Fr		
		Basic Dynamic Rated Load		Basic Static Rated Load		Basic Dynamic Rated Load		Basic Static Load		mm	mm	N	lb	
		Cr	Cr	Cr	Cr	Cr	Cr							
		N	lb	N	lb	Model	N	lb	N	lb				
14	698ZZ	2240	504	910	205	695ZZ	1080	243	430	97	20	14	110	25
17	6900ZZ	2700	607	1270	285	697ZZ	1610	362	710	160	23.5	21	135	30
20	6902ZZ	4350	978	2260	508	698ZZ	2240	504	910	205	26.5	23.3	210	47
25	6002ZZ	5600	1259	2830	636	6900ZZ	2700	607	1270	285	28	28	270	61
32	6004ZZ	9400	2113	5000	1124	6902ZZ	4350	978	2260	508	36	27	490	110
40	6006ZZ	13200	2967	8300	1866	6003ZZ	6000	1349	3250	731	43	32.5	660	148
45	6206ZZ	19500	4384	11300	2540	6004ZZ	9400	2113	5000	1124	47.5	34.5	1030	232
50	6207ZZ	25700	5777	15300	3439	6005ZZ	10100	2270	5850	1315	53	39	1330	299
58	6208ZZ	29100	6542	17800	4001	6006ZZ	13200	2967	8300	1866	62.5	40	1600	360
65	6209ZZ	32500	7306	20500	4608	6007ZZ	16000	3597	10300	2315	79	63	1650	371

Table 35

figure 1

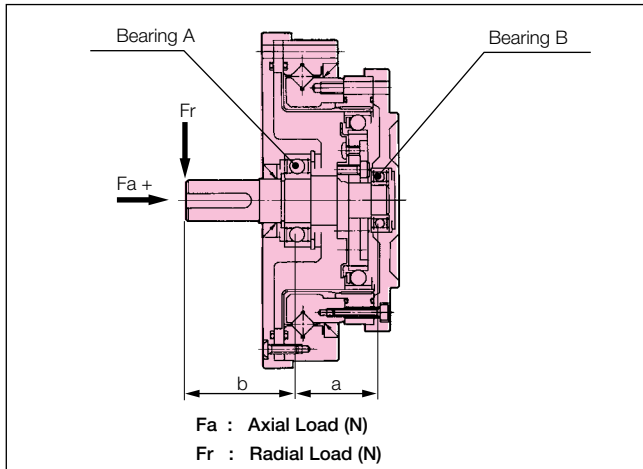

figure 2

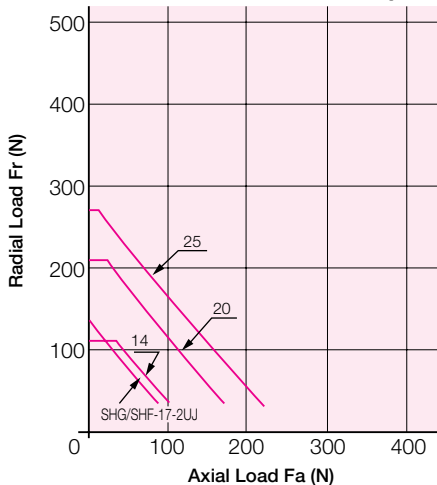
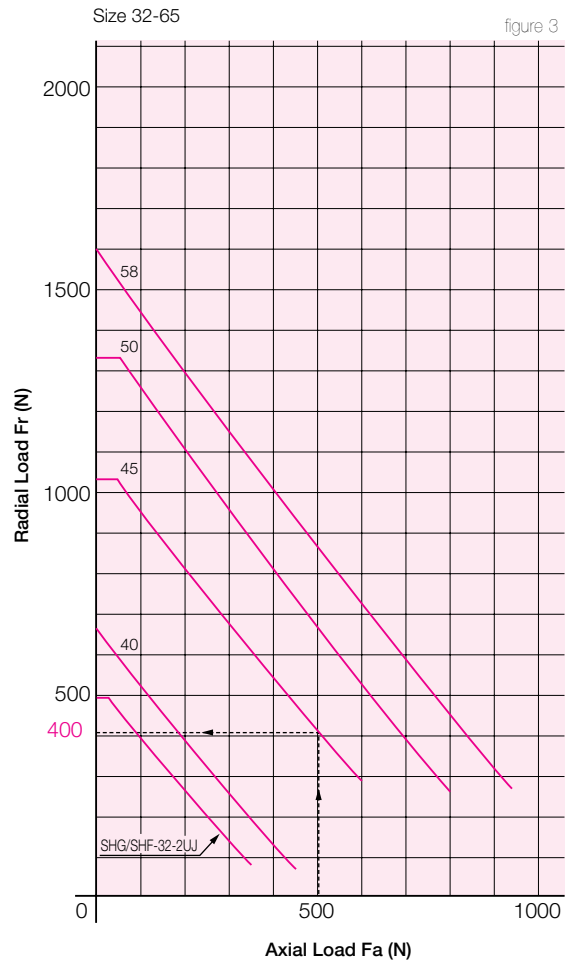
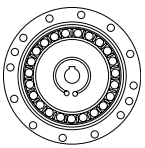

figure 3





EFFICIENCY

The efficiency depends on the conditions shown below.
 Efficiency depends on gear ratio, input speed, load torque, temperature, quantity of lubricant and type of lubricant.

Measurement Condition

- Installation : Based on recommended tolerance
- Load torque : Rated torque
- Lubricant : Harmonic Grease SK-1A
 Harmonic Grease SK-2
 Harmonic Grease 4B No.2
- Grease quantity : Recommended quantity

Please contact us for details pertaining to recommended oil lubricant.

Component Type (Size 14)

SK-2

Ratio 30

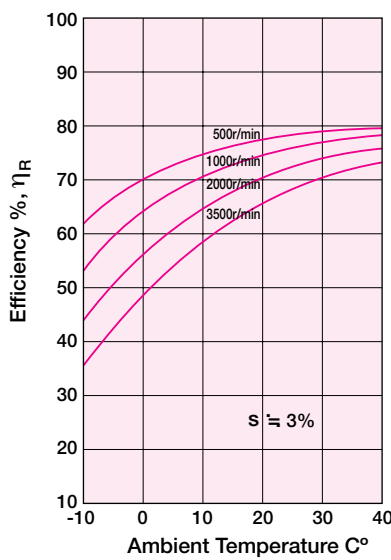

Ratio 50, 80

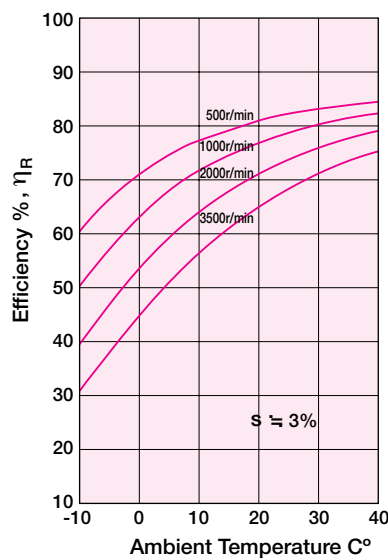

Ratio 100

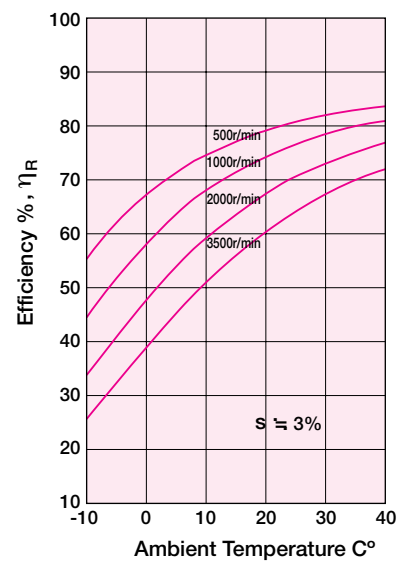

4BNo.2

Ratio 30

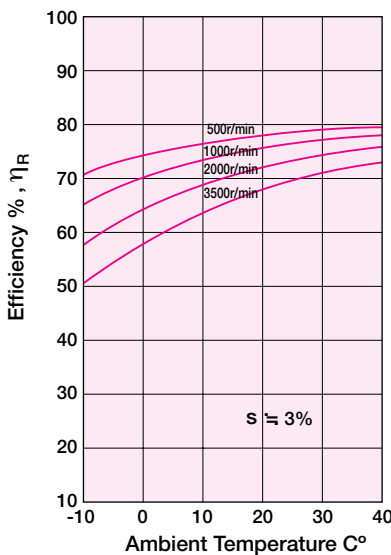

Ratio 50, 80

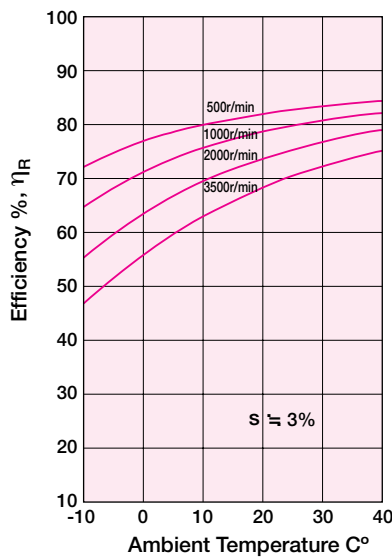

Ratio 100

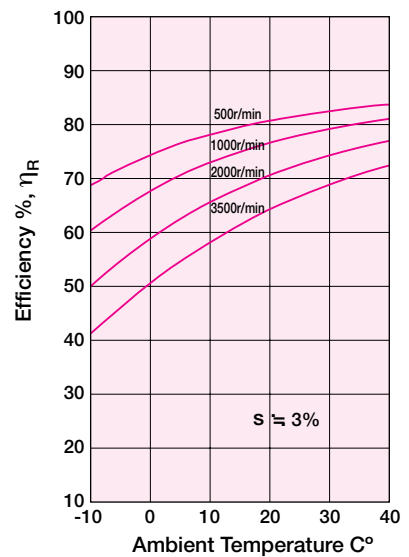

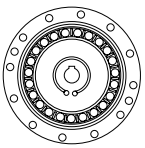

EFFICIENCY

Efficiency Compensation Coefficient

Efficiency value drops when load torque is smaller than rated torque.

Find the Compensation Coefficient (Ke) from figure (a) and calculate the efficiency.

For example: Find the efficiency η (%) on following condition using model SHF-20-80-2A-GR

- Input speed : 1000 r/min
- Load Torque : 19.6 Nm
- Type of lubricant : grease
- Temperature : 20°C

- Size 20 – ratio 80, rated torque = 34 Nm (see rated table, page 11) Torque $x = 19.6/34 = 0.58$
Efficiency Compensation Coefficient $K_e = 0.93$

Efficiency $\eta = K_e \cdot \eta_R = 0.93 \times 82 = 76\%$

The load torque is greater than the rated torque : The efficiency compensation coefficient $K_e=1$

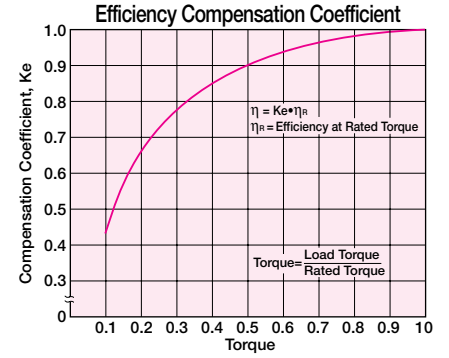

Component Type (Size 17-65)

SK-1A, SK-2

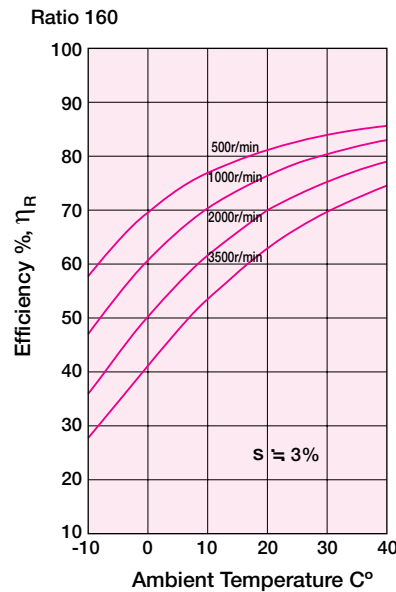
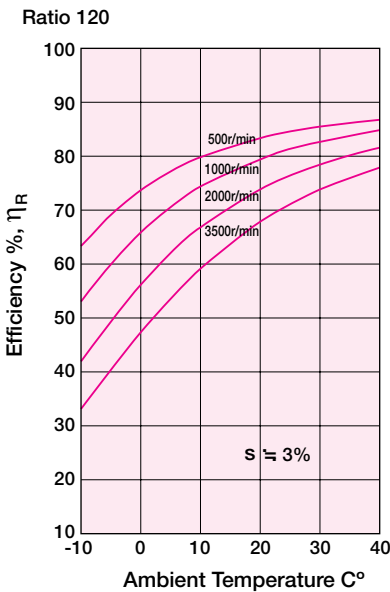
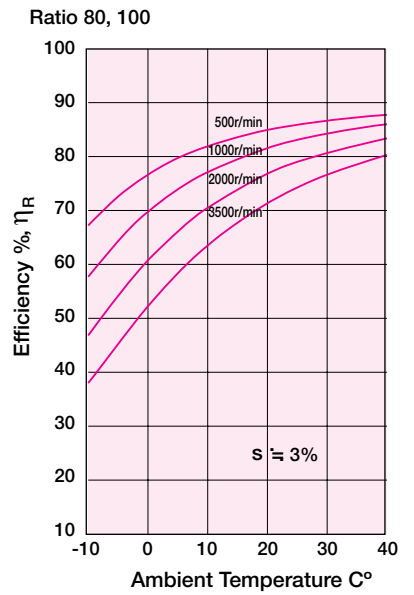
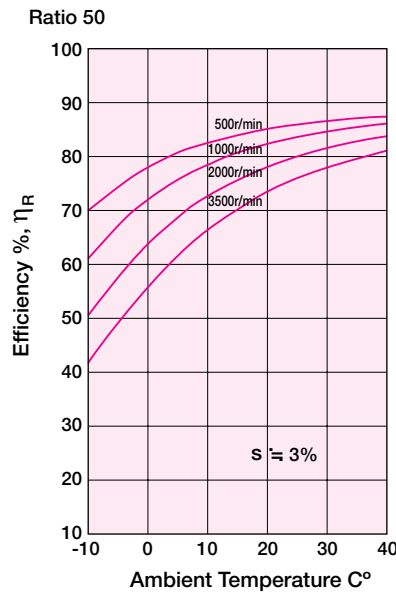
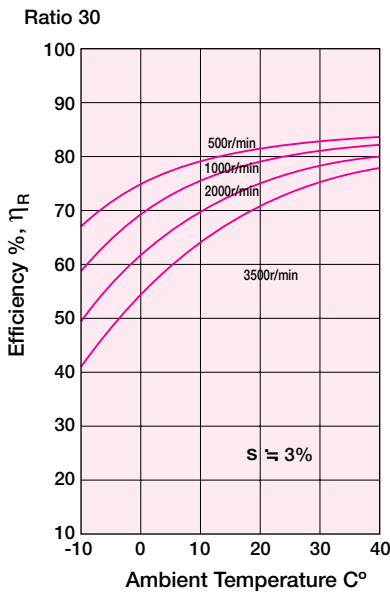

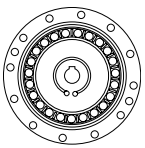

Component Type (Size 17-65)

4BNo.2

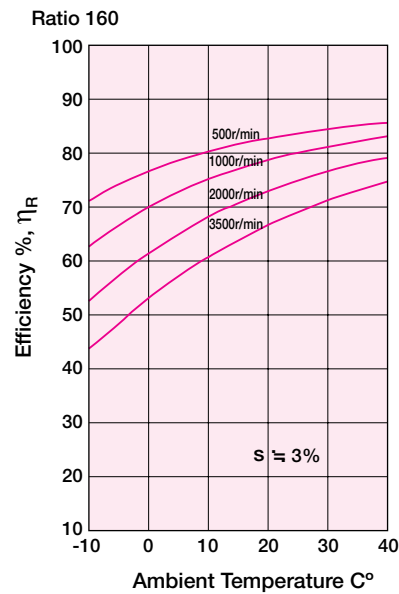
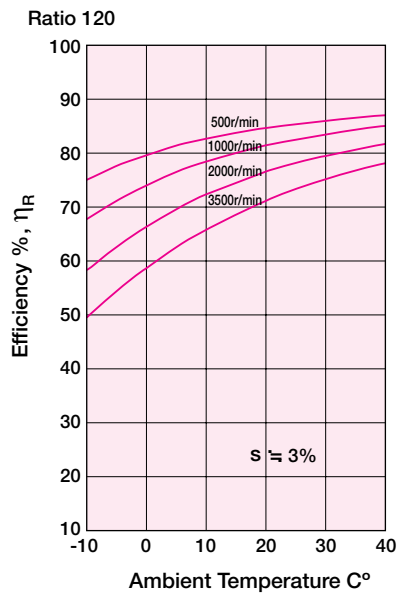
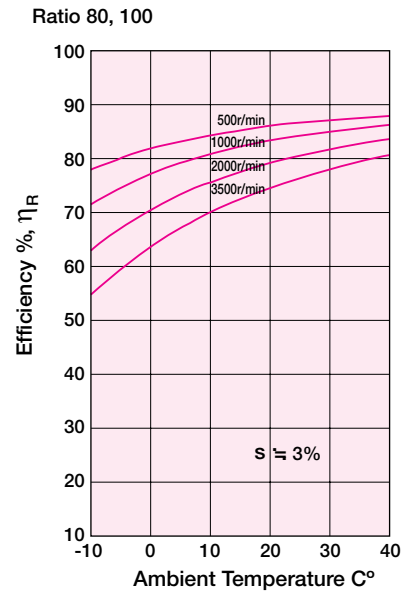
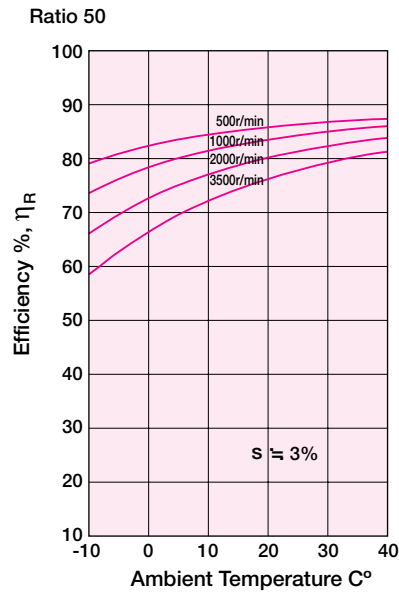
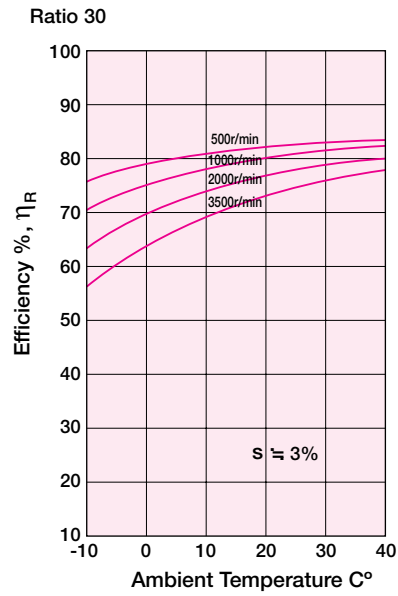

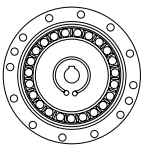

Unit Type Hollow Shaft Type (2UH) (Size 11-65)

SK-1A, SK-2

Ratio 30

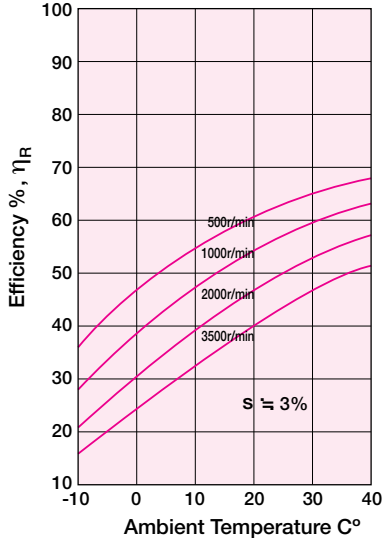

Ratio 50, 80, 100, 120

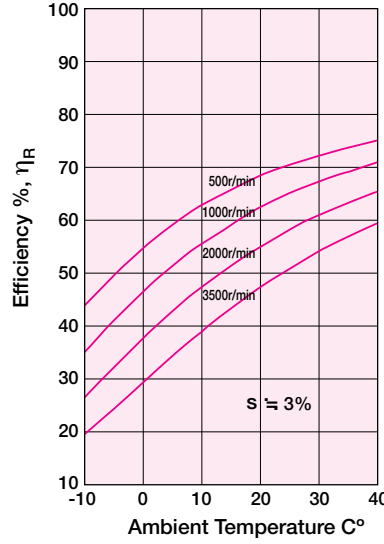

Ratio 160

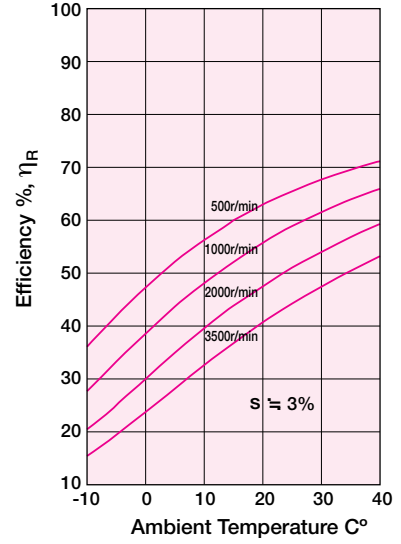

■ SHF-11-50

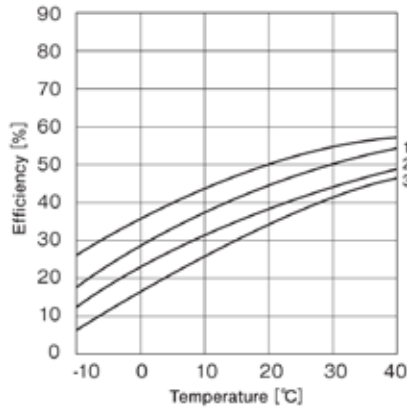

■ SHF-11-100

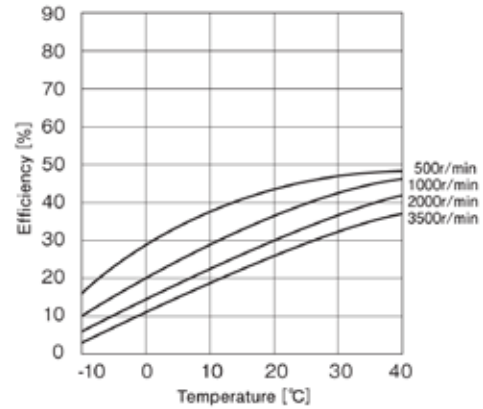

4B No. 2

* The above graphs are based on calculated values. * Lubrication Grease: Harmonic Grease SK-2

Ratio 30

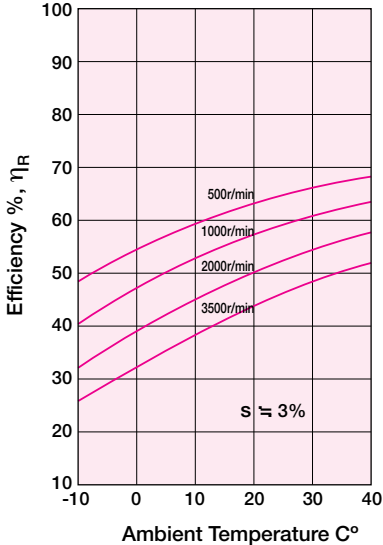

Ratio 50, 80, 100, 120

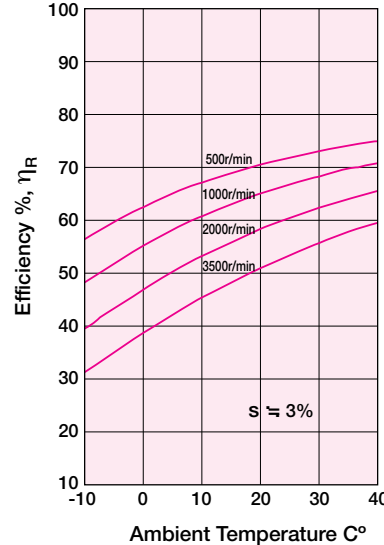

Ratio 160

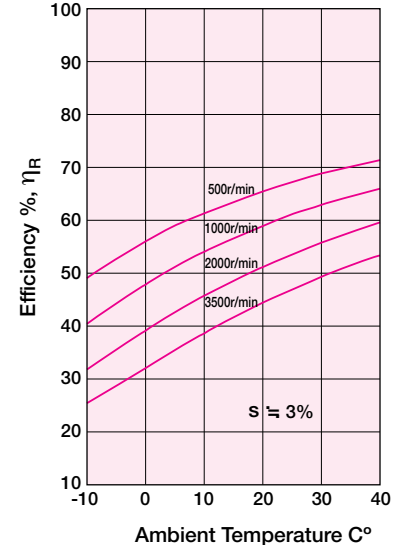

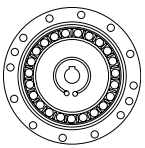

Input Shaft Type (2UJ) (Size 14-65)

SK-1A, SK-2

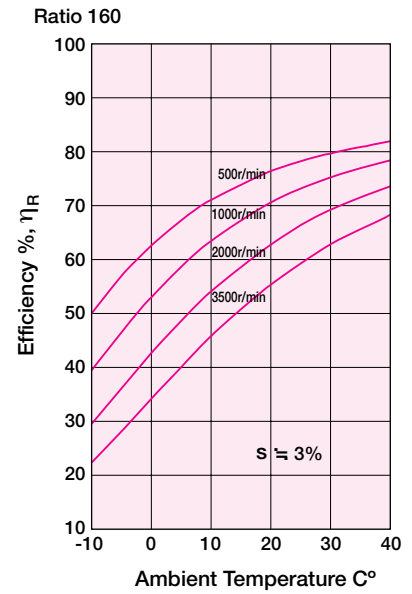
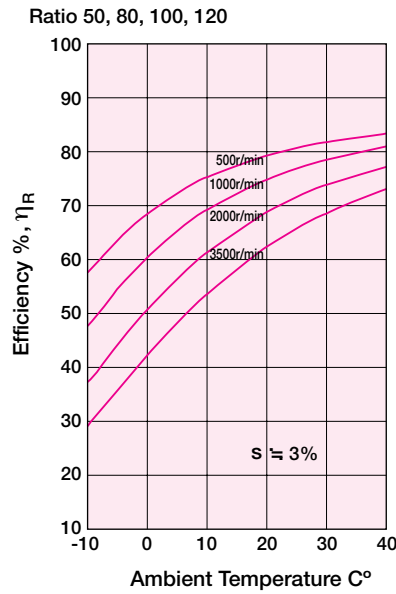
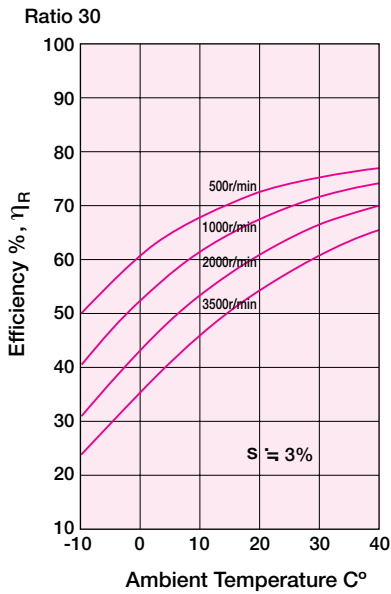

4BNo.2

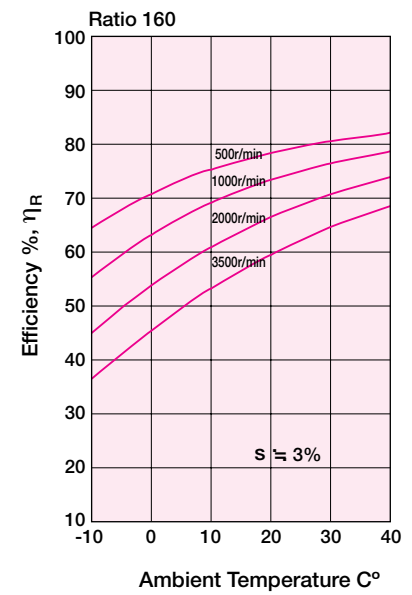
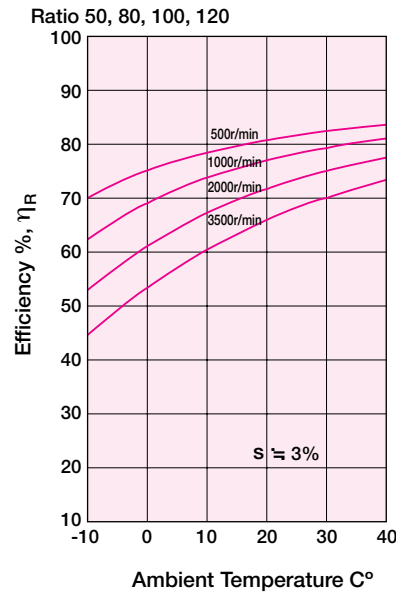
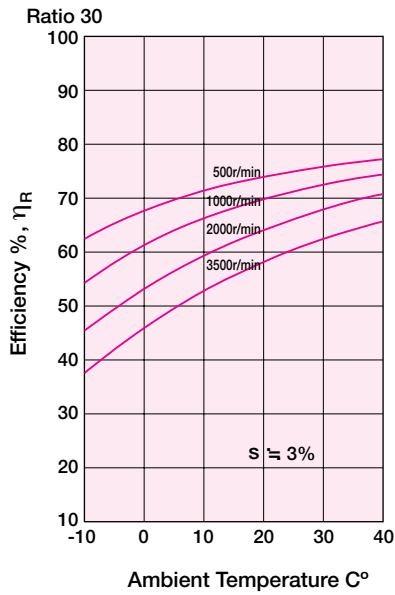

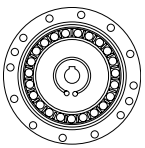

No Load Running Torque

No Load Running Torque (NLRT)

No load running torque indicates the torque which is needed to rotate input of the gear, "Wave Generator", with no load on the output side (low speed side).

Please contact us regarding details.

Measurement Condition for NLRT Graphs

Ratio	: 1/100
Lubricant	: Harmonic Grease SK-1A Harmonic Grease SK-2 Harmonic Grease 4B No.2
Quantity	: Recommended quantity see page 19

Torque value is measured after 2 hours at 2000rpm input.

Please contact us for details pertaining to recommended lubricants.

Component Type

SK-1A, SK-2

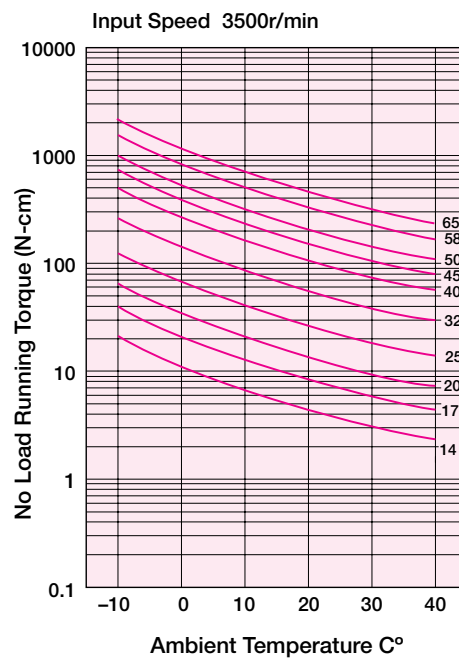
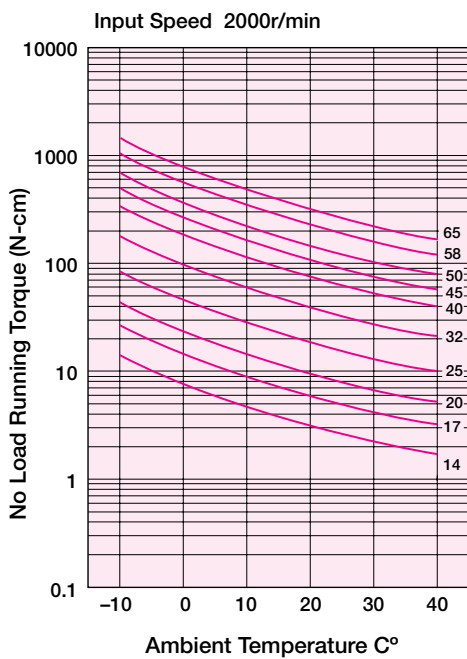
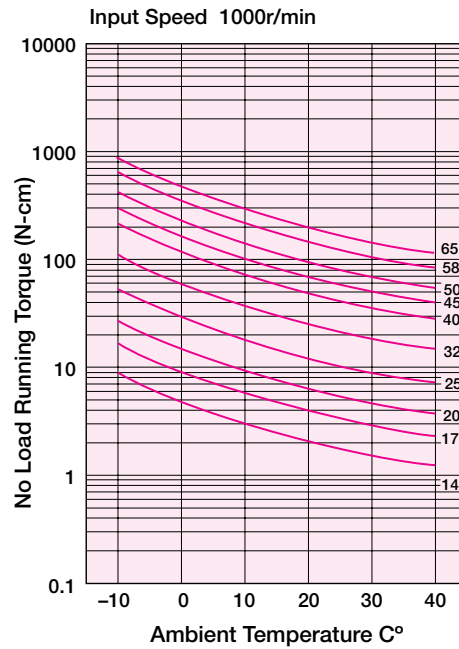
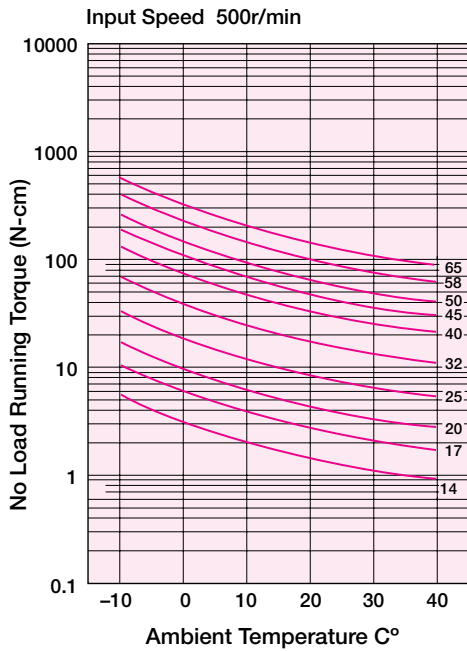

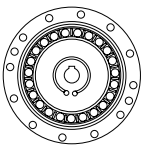

No Load Running Torque

Compensation Value in Each Ratio

No load running torque of the gear varies with ratio. The graphs indicate a value for ratio 100. For other gear ratios, add the compensation values from table on the right.

Component Set No Load Torque Compensation Value Ncm

Ratio Size	30	50	80	120	160
14	+1.2	+0.5	+0.1	-	-
17	+2.1	+0.9	+0.1	-0.1	-
20	+3.1	+1.4	+0.2	-0.2	-0.4
25	+5.7	+2.5	+0.4	-0.3	-0.7
32	+11.7	+5.2	+0.8	-0.6	-1.4
40	-	+9.2	+1.4	-1.0	-2.5
45	-	+12.7	+2.0	-1.4	-3.5
50	-	+17.0	+2.6	-1.9	-4.6
58	-	+25.8	+4.0	-2.9	-7.0
65	-	-	+5.4	-4.0	-9.7

Component Type 4B No.2

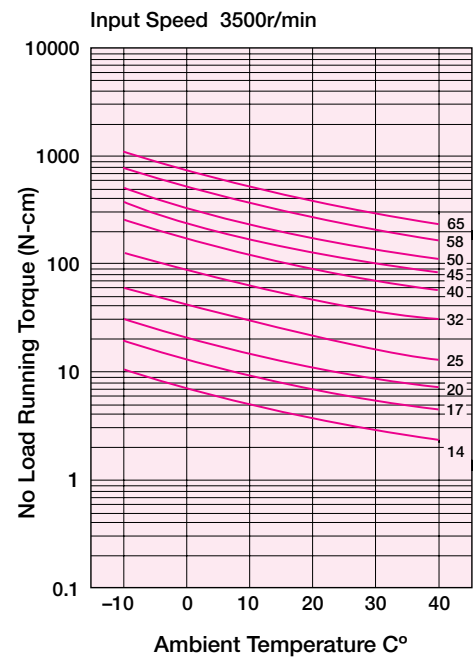
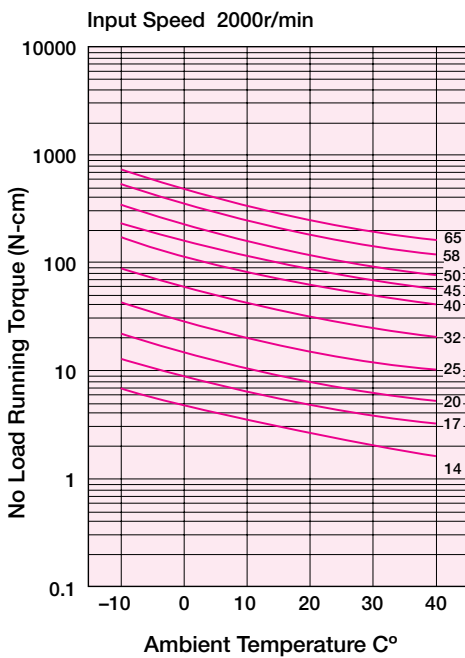
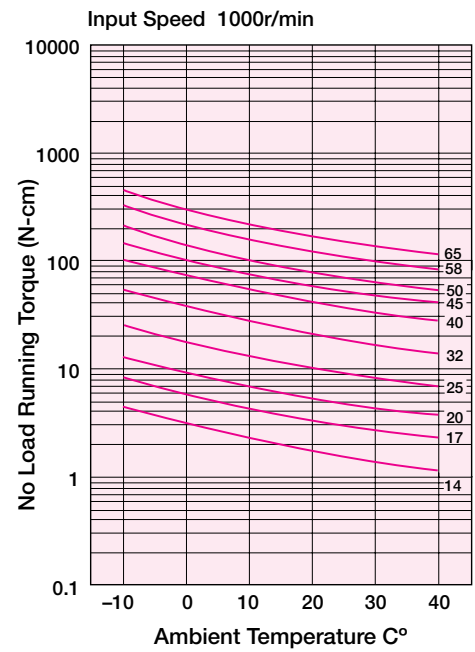
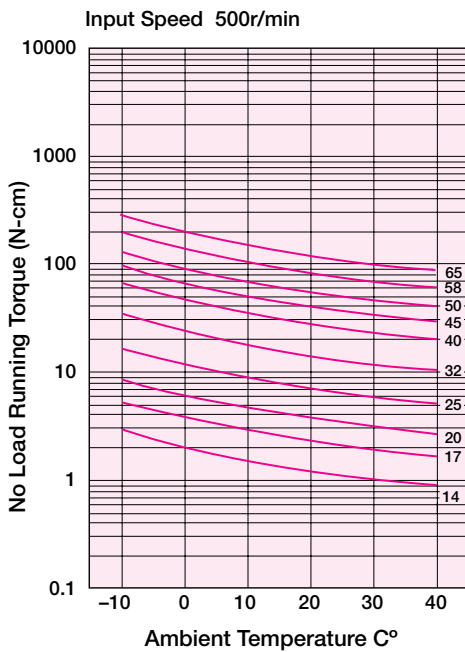

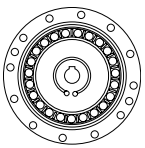

Compensation Value in Each Ratio

No load running torque of the gear varies with ratio. The graphs indicate a value for ratio 100. For other ratios, add the compensation values from the table on the right.

Ratio Size	30	50	80	120	160
14	+2.6	+1.1	+0.2	-	-
17	+4.1	+1.8	+0.4	-0.2	-
20	+5.9	+2.6	+0.5	-0.4	-0.8
25	+9.6	+4.2	+0.8	-0.6	-1.3
32	+18.3	+8.0	+1.5	-1.1	-2.5
40	-	+13.3	+2.4	-1.7	-4.0
45	-	+18.2	+3.3	-2.4	-5.5
50	-	+23.9	+4.3	-3.1	-7.2
58	-	+34.6	+6.2	-4.4	-10.3
65	-	-	+8.1	-5.8	-13.7

Unit Type: Hollow Type (2UH) 4B No. 2

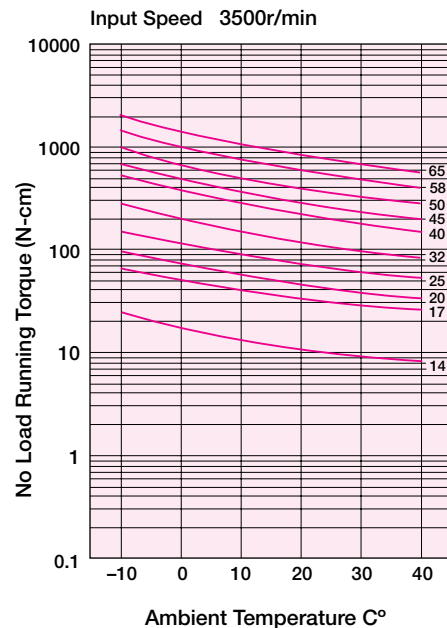
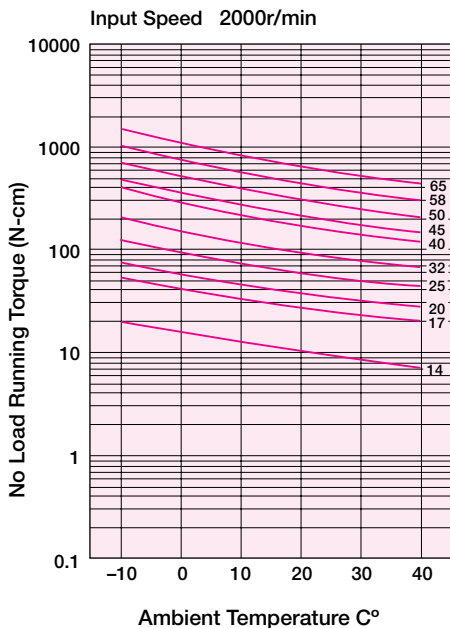
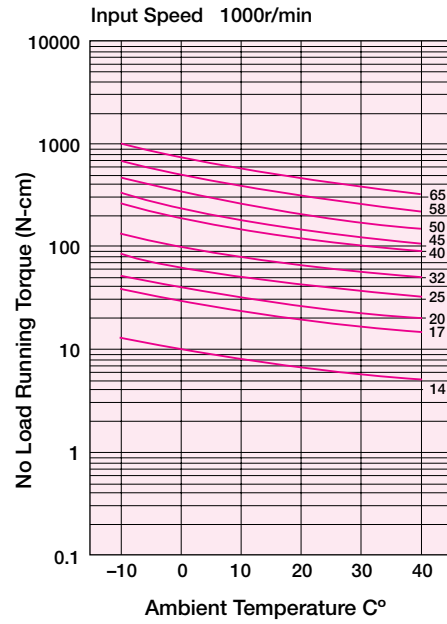
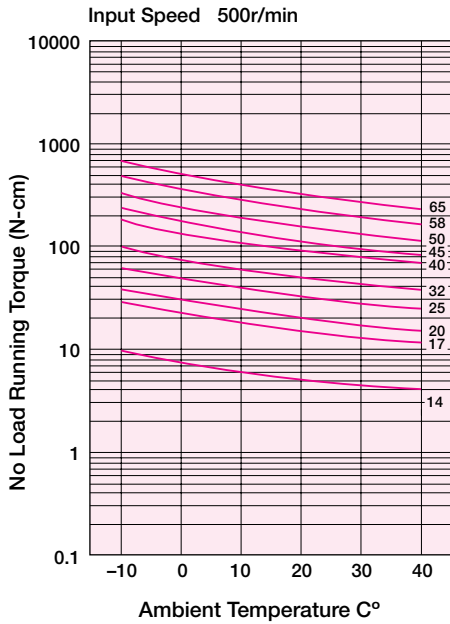

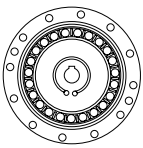

Unit Type: Hollow Type (2UH)
SK-1A, SK-2

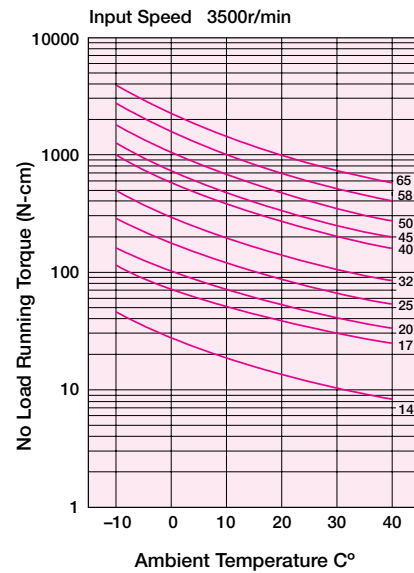
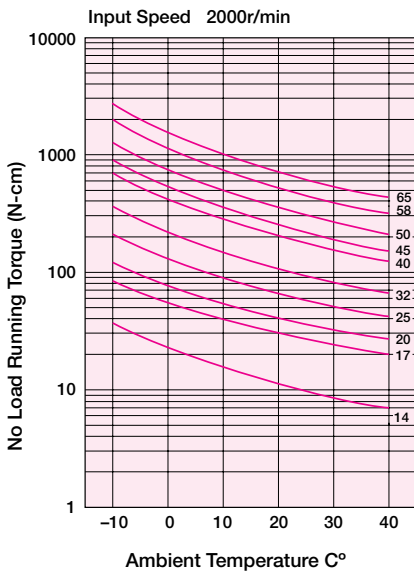
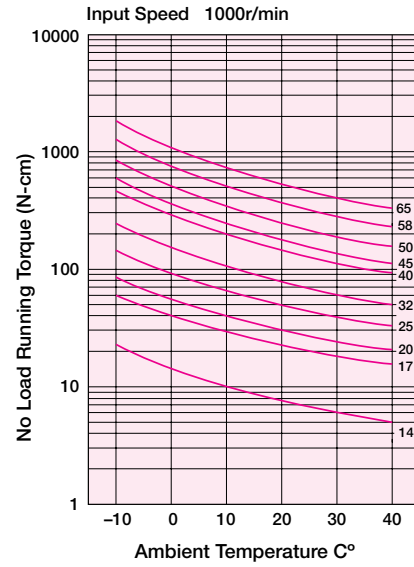
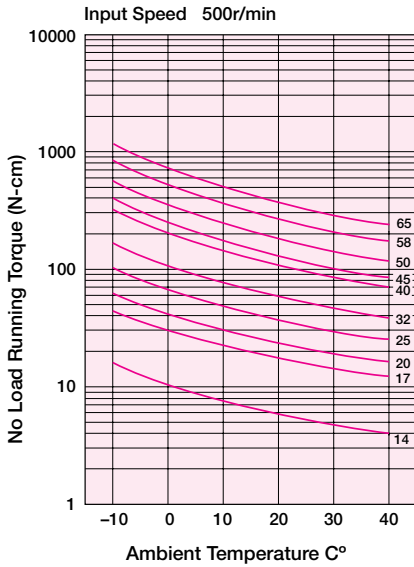

■ SHF-11-50-2UH

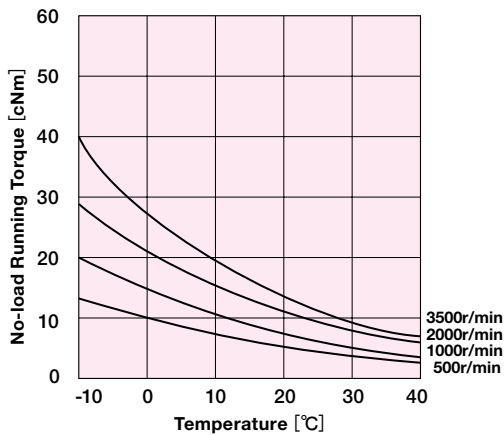

■ SHF-11-100-2UH

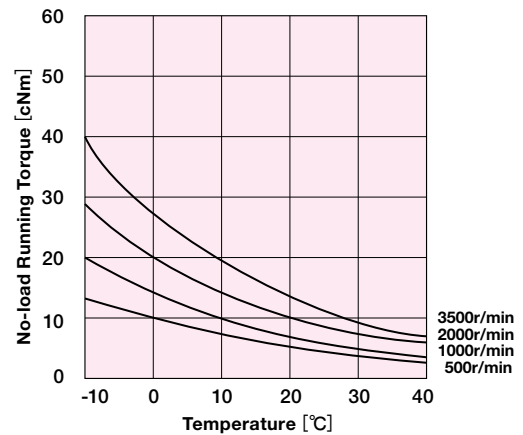

* The above graphs are based on calculated values. * Lubrication Grease: Harmonic Grease SK-2

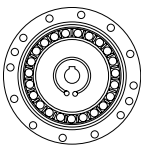

Compensation Value in Each Ratio

No load running torque of the gear varies with ratio. The graphs indicate a value for ratio 100. For other ratios, add the compensation values from the table on the right.

		No Load Torque Running Torque Compensation Value Ncm				
Ratio Size	30	50	80	120	160	
14	+2.6	+1.1	+0.2	-	-	
17	+4.1	+1.8	+0.4	-0.2	-	
20	+5.9	+2.6	+0.5	-0.4	-0.8	
25	+9.6	+4.2	+0.8	-0.6	-1.3	
32	+18.3	+8.0	+1.5	-1.1	-2.5	
40	-	+13.3	+2.4	-1.7	-4.0	
45	-	+18.2	+3.3	-2.4	-5.5	
50	-	+23.9	+4.3	-3.1	-7.2	
58	-	+34.6	+6.2	-4.4	-10.3	
65	-	-	+8.1	-5.8	-13.7	

Unit Type: Input Shaft Type (2UJ)

4B No. 2

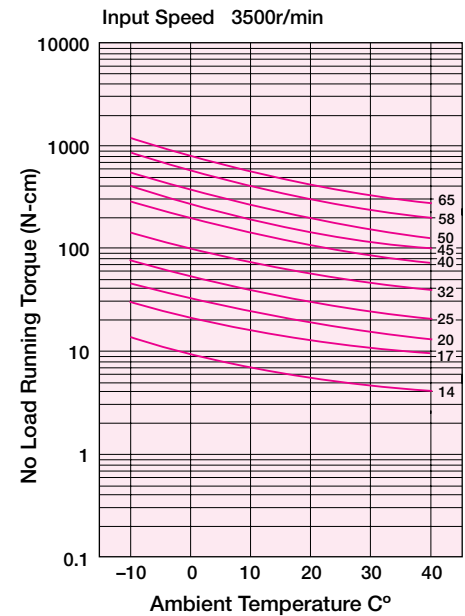
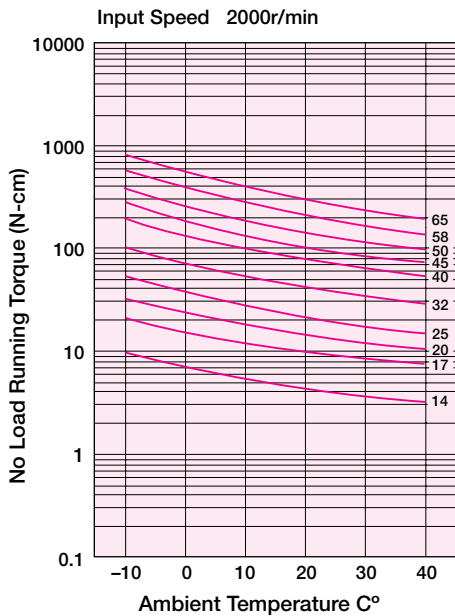
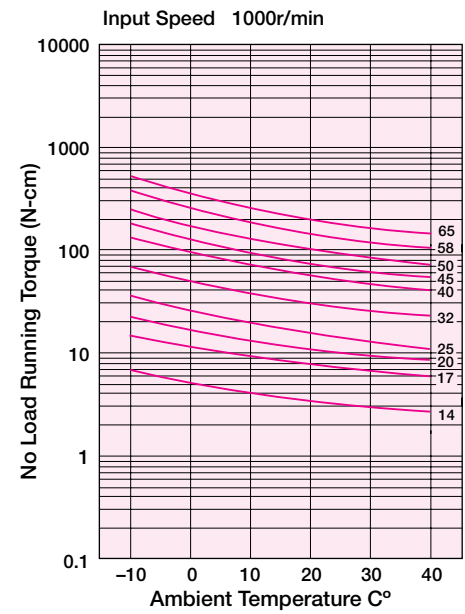
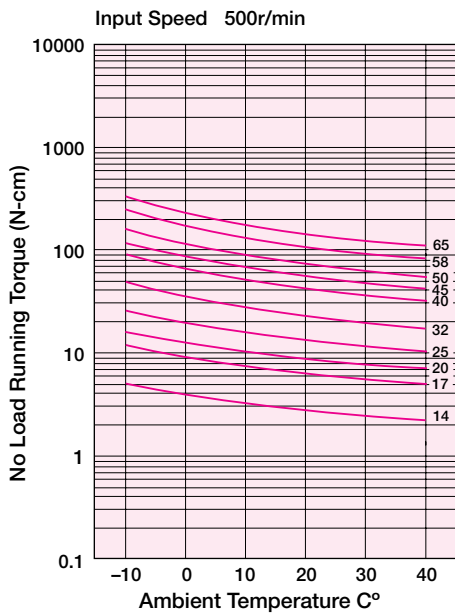

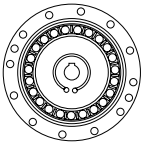

Unit Type: Input Shaft Type (2UJ)

SK-1A, SK-2

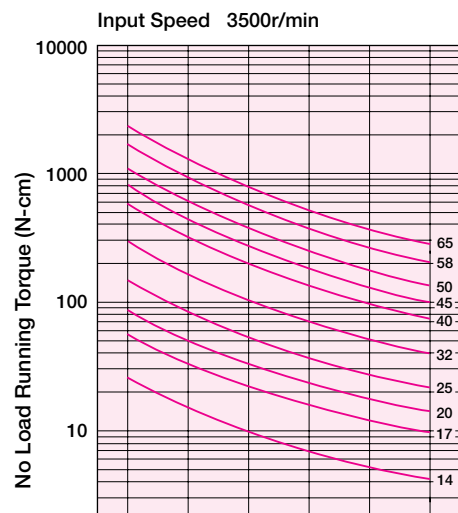
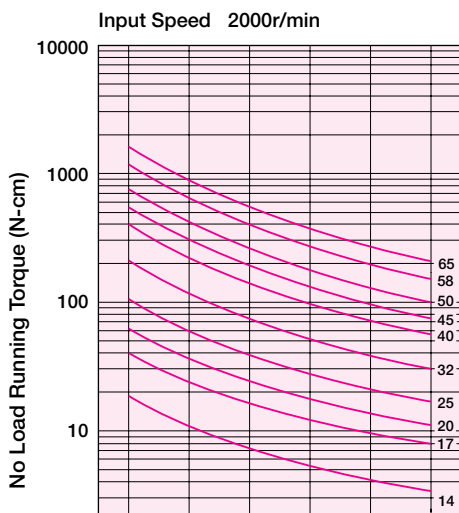
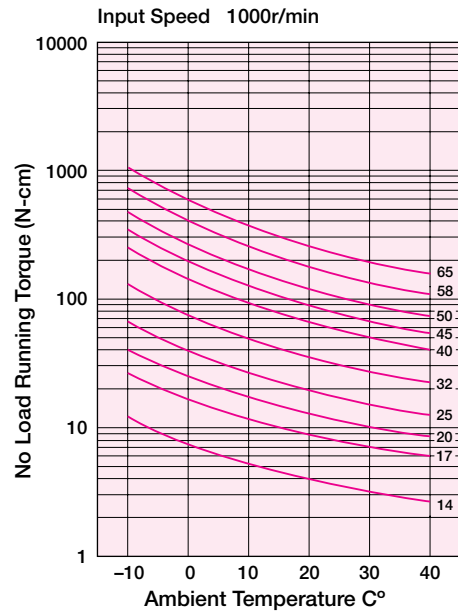
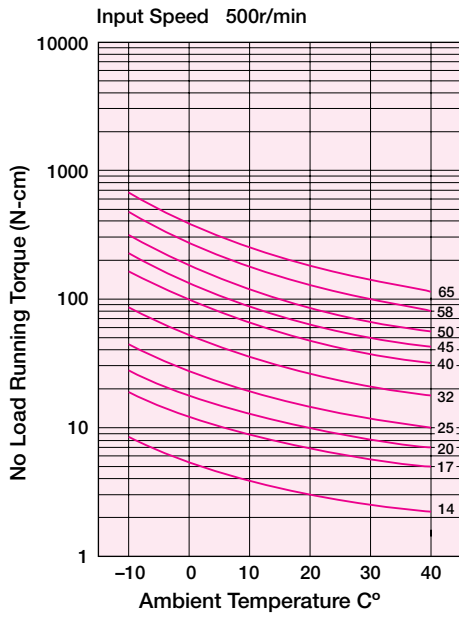

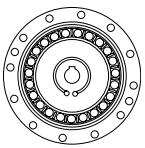

STARTING TORQUE AND BACKDRIVING TORQUE

Starting Torque

Starting torque is the torque required to commence rotation of the input element (high speed side), with no load being applied to the output. The table below indicates the maximum values. The lower values are approximately 1/2 to 1/3 of the maximum values.

Backdriving torque is the torque required to commence rotation of input element (high speed side) when torque is applied on the output side (low speed side). The table below indicates the maximum values. The typical values are approximately 1/2 to 1/3 of the maximum values. The backdriving torque should not be relied upon to provide a holding torque to prevent the output from backdriving. A failsafe brake should be used for this purpose.

Measurement condition: Ambient temperature 20°C

Values shown below vary depending on condition. Please use values as a reference.

Component Type Backdriving Torque

Starting Torque for Component Set Unit (N•cm) Table 36

Size	14	17	20	25	32	40	45	50	58	65
30	4.8	7.2	12	18	50	-	-	-	-	-
50	3.7	5.7	7.3	14	28	50	70	94	140	-
80	2.8	3.8	4.8	8.9	19	33	47	63	94	128
100	2.4	3.3	4.3	7.9	18	29	41	56	83	114
120	-	3.1	3.9	7.3	15	27	37	51	76	104
160	-	-	3.4	6.4	14	24	33	44	68	94

Backdriving Torque for Component Set Unit (N•m) Table 37

Size	14	17	20	25	32	40	45	50	58	65
30	2.3	3.5	6.1	11	23	-	-	-	-	-
50	2.2	3.4	4.4	8.2	17	30	42	56	84	-
80	2.7	3.7	4.6	8.6	18	32	45	60	90	123
100	2.8	4	5.2	9.5	21	35	49	67	100	137
120	-	4.5	5.6	10	21	40	54	73	110	151
160	-	-	6.6	12	26	45	64	85	130	180

Starting Torque for Hollow Shaft Type (2UH) Unit (N•cm) Table 38

Size	11	14	17	20	25	32	40	45	50	58	65
30	-	11	30	43	64	112	-	-	-	-	-
50	7.1	8.8	27	36	56	85	136	165	216	297	-
80	-	7.5	25	33	50	74	117	138	179	244	314
100	5.9	6.9	24	32	49	72	112	131	171	231	297
120	-	-	24	31	48	68	110	126	165	223	287
160	-	-	31	47	67	105	122	156	213	276	-

Backdriving Torque for Hollow Shaft Type (2UH) Unit (N•m) Table 39

Size	11	14	17	20	25	32	40	45	50	58	65
30	-	5.4	17	23	35	57	-	-	-	-	-
50	4.6	5.3	16	22	34	51	82	99	129	178	-
80	-	7.2	24	31	48	70	112	133	172	234	301
100	7.6	8.2	29	38	59	86	134	158	205	278	356
120	-	-	34	45	69	97	158	182	237	322	413
160	-	-	59	90	128	201	233	299	408	530	-

Starting Torque for Input Shaft Type (2UJ) Unit (N•cm) Table 40

Size	14	17	20	25	32	40	45	50	58	65
30	6.8	11	19	26	63	-	-	-	-	-
50	5.7	9.7	14	22	41	72	94	125	178	-
80	4.4	7.2	11	15	29	52	68	88	125	163
100	3.7	6.5	9.9	14	27	47	60	80	113	147
120	-	6.2	9.3	13	24	44	55	74	105	137
160	-	-	8.6	12	23	39	50	66	94	122

Backdriving Torque for Input Shaft Type (2UJ) Unit (N•m) Table 41

Size	14	17	20	25	32	40	45	50	58	65
30	3.5	5.9	10	16	31	-	-	-	-	-
50	3.4	5.8	8.4	13	25	43	56	75	107	-
80	4.2	6.9	10	15	28	50	65	85	120	154
100	4.5	7.8	12	17	33	56	72	96	135	176
120	-	8.9	13	19	34	63	79	106	151	198
160	-	-	17	23	43	75	96	126	181	235

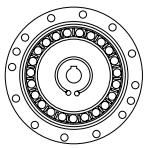

POSITIONING ACCURACY

Positioning Accuracy

The positioning accuracy of the gear represents a linearity error between the input and output angle. The position error is the difference between theoretical and actual output rotation angle.

The positioning accuracy is measured for one complete output revolution using a high resolution measurement system. The measurements are carried out without reversing direction.

The positioning accuracy is defined as the difference between the maximum positive and maximum negative deviation from the theoretical position.

- θ_{er}Positional Accuracy
- θ_iInput Angle
- θ_oActual Output Angle
- R.....Gear Ratio

$$\theta_{er} = \theta_o - \frac{\theta_i}{R}$$

Typical Positional Accuracy Curve

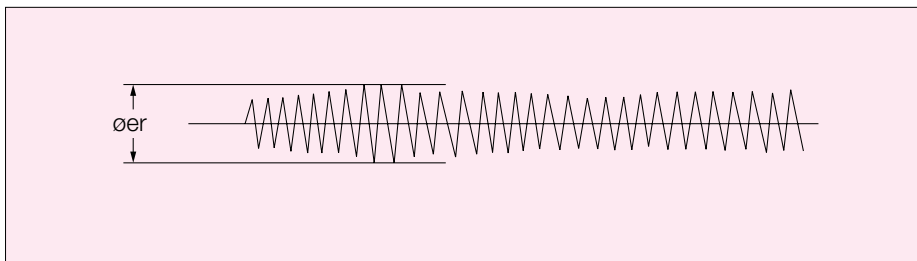

Position Accuracy

Size 11		x 10 ⁻⁴ rad (arc-min)	
Gear Ratio	Standard	11	
50	x 10 ⁻⁴ rad	5.8	
	arc/min	2	
100	x 10 ⁻⁴ rad	4.4	
	arc/min	1.5	

Sizes 14-65			x 10 ⁻⁴ rad (arc-min) Table 42				
Gear Ratio		14	17	20	25	32	40-65
30	standard	5.8 (2)	4.4 (1.5)	4.4 (1.5)	4.4 (1.5)	4.4 (1.5)	- -
	special	- -	- -	2.9 (1)	2.9 (1)	2.9 (1)	- -
50 and larger	standard	4.4 (1.5)	4.4 (1.5)	2.9 (1)	2.9 (1)	2.9 (1)	2.9 (1)
	special	2.9 (1)	2.9 (1)	1.5 (0.5)	1.5 (0.5)	1.5 (0.5)	1.5 (0.5)

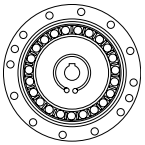

TORSIONAL STIFFNESS

Torsional Stiffness

Torsional stiffness is determined by applying a load to the output of the gear, with the input rotationally locked.

The angular rotation is measured as the load is increased.

The typical curve (shown in the figure 11) is non-linear.

The stiffness is determined the slope of this curve. For simplicity, the curve is approximated by 3 straight lines having stiffness of K_1 , K_2 , and K_3 .

Stiffness K_1 applies for output torque of 0 to T_1 .

Stiffness K_3 applies for output torque greater than T_2 .

Stiffness K_2 applies for output torque between T_1 and T_2 .

Typical stiffness values are shown in tables 43, 44 and 45.

Figure 10

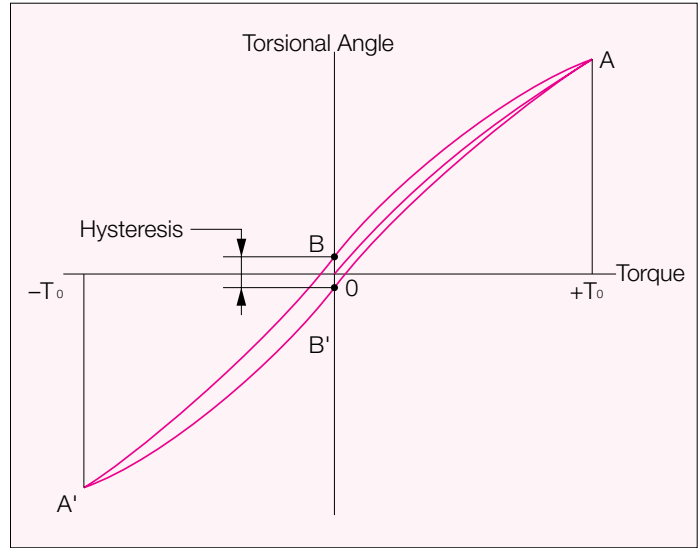
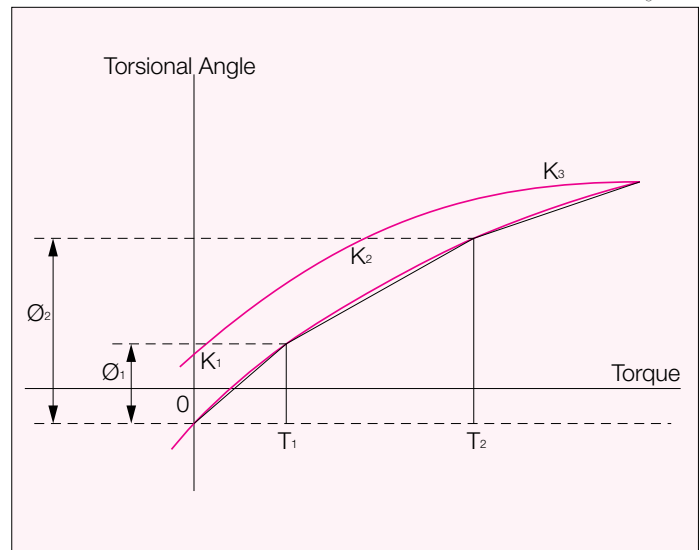
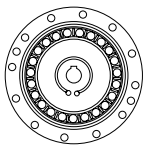

Figure 11





TORSIONAL STIFFNESS

Torsional Stiffness for Ratio 30:1

Table 43

Item	Size	14	17	20	25	32
T1	N.m	2.0	3.9	7.0	14	29
	In.lb	18	35	62	124	257
K1	X10 ⁴ N.m/rad	0.19	0.34	0.57	1.0	2.4
	In.lb/arc-min	5	9	15	26	62
Ø1	X10 ⁻⁴ rad	10.5	11.5	12.3	14	12.1
	arc-min	3.6	4.0	4.1	4.7	4.3
T2	N.m	6.9	12	25	48	108
	In.lb	61	106	221	425	956
K2	X10 ⁴ N.m/rad	0.24	0.44	0.71	1.3	3.0
	In.lb/arc-min	6	11	18	33	77
Ø2	X10 ⁻⁴ rad	31	30	38	40	38
	arc-min	10.7	10.2	12.7	13.4	13.3
K3	X10 ⁴ N.m/rad	0.34	0.67	1.1	2.1	4.9
	In.lb/arc-min	9	17	28	54	126

Numbers are average value.

Torsional Stiffness for Ratio 50:1

Table 44

Item	Size	11	14	17	20	25	32	40	45	50	58
T1	N.m	0.8	2.0	3.9	7.0	14	29	54	76	108	168
	In.lb	7	18	35	62	124	257	478	673	956	1487
K1	X10 ⁴ N.m/rad	0.22	0.34	0.81	1.3	2.5	5.4	10	15	20	31
	In.lb/arc-min	6	9	21	33	64	139	258	386	515	798
Ø1	X10 ⁻⁴ rad	3.6	5.8	4.9	5.2	5.5	5.5	5.2	5.2	5.5	5.2
	arc-min	1.2	2.0	1.7	1.8	1.9	1.9	1.8	1.8	1.9	1.8
T2	N.m	2.0	6.9	12	25	48	108	196	275	382	598
	In.lb	18	61	106	221	425	956	1735	2434	3381	5292
K2	X10 ⁴ N.m/rad	0.30	0.47	1.1	1.8	3.4	7.8	14	20	28	44
	In.lb/arc-min	8	12	28	46	88	201	361	515	721	1133
Ø2	X10 ⁻⁴ rad	8.0	16	12	15.4	15.7	15.7	15.4	15.1	15.4	15.1
	arc-min	2.6	5.6	4.2	5.3	5.4	5.4	5.3	5.2	5.3	5.2
K3	X10 ⁴ N.m/rad	0.32	0.57	1.3	2.3	4.4	9.8	18	26	34	54
	In.lb/arc-min	8	15	33	59	113	252	464	670	876	1391

Numbers are average value.

Torsional Stiffness for Ratio 80:1+

Table 45

Item	Size	11	14	17	20	25	32	40	45	50	58	65
T1	N.m	0.8	2.0	3.9	7.0	14	29	54	76	108	168	235
	In.lb	7	18	35	62	124	257	478	673	956	1487	2080
K1	X10 ⁴ N.m/rad	0.27	0.47	1	1.6	3.1	6.7	13	18	25	40	54
	In.lb/arc-min	7	12	26	41	80	173	335	464	644	1030	1391
Ø1	X10 ⁻⁴ rad	3	4.1	3.9	4.4	4.4	4.4	4.1	4.1	4.4	4.1	4.4
	arc-min	1	1.4	1.3	1.5	1.5	1.5	1.4	1.4	1.5	1.4	1.5
T2	N.m	2.0	6.9	12	25	48	108	196	275	382	598	843
	In.lb	18	61	106	221	425	956	1735	2434	3381	5292	7461
K2	X10 ⁴ N.m/rad	0.34	0.61	1.4	2.5	5.0	11	20	29	40	61	88
	In.lb/arc-min	9	16	36	64	129	283	515	747	1030	1571	2266
Ø2	X10 ⁻⁴ rad	6.0	12	9.7	11.3	11.1	11.6	11.1	11.1	11.1	11.1	11.3
	arc-min	2.2	4.2	3.3	3.9	3.8	4.0	3.8	3.8	3.8	3.8	3.9
K3	X10 ⁴ N.m/rad	0.44	0.71	1.6	2.9	5.7	12	23	33	44	71	98
	In.lb/arc-min	11	18	41	75	147	309	592	850	1133	1828	2524

Numbers are average value.

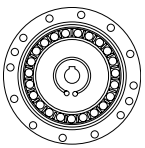

Hysteresis Loss

A typical hysteresis curve is shown in figure 10. With the input locked, a torque is applied from 0 to \pm Rated Torque. Hysteresis measurement is shown in the figure. The following table shows typical hysteresis values.

Hysteresis Loss

Table 46

Size		11	14	17	20	25	32	40 and over
30	X10 ⁻⁴ rad	-	8.7	8.7	8.7	8.7	8.7	-
	arc min	-	3	3	3	3	3	-
50	X10 ⁻⁴ rad	5.8	2.9	2.9	2.9	2.9	2.9	2.9
	arc min	2.0	1	1	1	1	1	1
80+	X10 ⁻⁴ rad	5.8	2.9	2.9	2.9	2.9	2.9	2.9
	arc min	2.0	1	1	1	1	1	1

Backlash from Oldham Coupling

The gear element has zero backlash. However, an Oldham coupling is included as standard with all gearing components and gearheads. The Oldham coupling compensates for motor shaft concentricity errors. Unfortunately, the Oldham coupling does add a small amount of backlash to the system. Backlash values are shown in table 44. This amount of backlash is usually negligible. Component sets and gearheads can be supplied without an Oldham coupling. This is called a "Direct Drive" version.

Backlash from Oldham Coupling

Table 47

Size		14	17	20	25	32	40	45	50	58	65
30	X10 ⁻⁵ rad	29.1	16.0	13.6	13.6	11.2	-	-	-	-	-
	arc sec	60	33	28	28	23	-	-	-	-	-
50	X10 ⁻⁵ rad	17.5	9.7	8.2	8.2	6.8	6.8	5.8	5.8	4.8	-
	arc sec	36	20	17	17	14	14	12	12	10	-
80	X10 ⁻⁵ rad	11.2	6.3	5.3	5.3	4.4	4.4	3.9	3.9	2.9	2.9
	arc sec	23	13	11	11	9	9	8	8	6	6
100	X10 ⁻⁵ rad	8.7	4.8	4.4	4.4	3.4	3.4	2.9	2.9	2.4	2.4
	arc sec	18	10	9	9	7	7	6	6	5	5
120	X10 ⁻⁵ rad	-	3.9	3.9	3.9	2.9	2.9	2.4	2.4	1.9	1.9
	arc sec	-	8	8	8	6	6	5	5	4	4
160	X10 ⁻⁵ rad	-	-	2.9	2.9	2.4	2.4	1.9	1.9	1.5	1.5
	arc sec	-	-	6	6	5	5	4	4	3	3

Calculate Torsion Angle

- For $T < T_1$: $\Theta = T/K_1$
- For $T_1 < T < T_2$: $\Theta = T_1/K_1 + (T - T_1)/K_2$
- For $T_2 < T$: $\Theta = T_1/K_1 + (T_2 - T_1)/K_2 + (T - T_2)/K_3$

Note: Units for T, T₁, T₂, K, K₁, K₂, K₃, and Θ must be consistent.

All products are warranted to be free from design or manufacturing defects for a period of one year from the date of shipment. Such items will be repaired or replaced at the discretion of Harmonic Drive LLC. The seller makes no warranty, expressed or implied, concerning the material to be furnished other than it shall be of the quality and specifications stated. The seller's liability for any breach is limited to the purchase price of the product. All efforts have been made to assure that the information in this catalog is complete and accurate. However, Harmonic Drive LLC is not liable for any errors, omissions or inaccuracies in the reported data. Harmonic Drive LLC reserves the right to change the product specifications, for any reason, without prior notice.

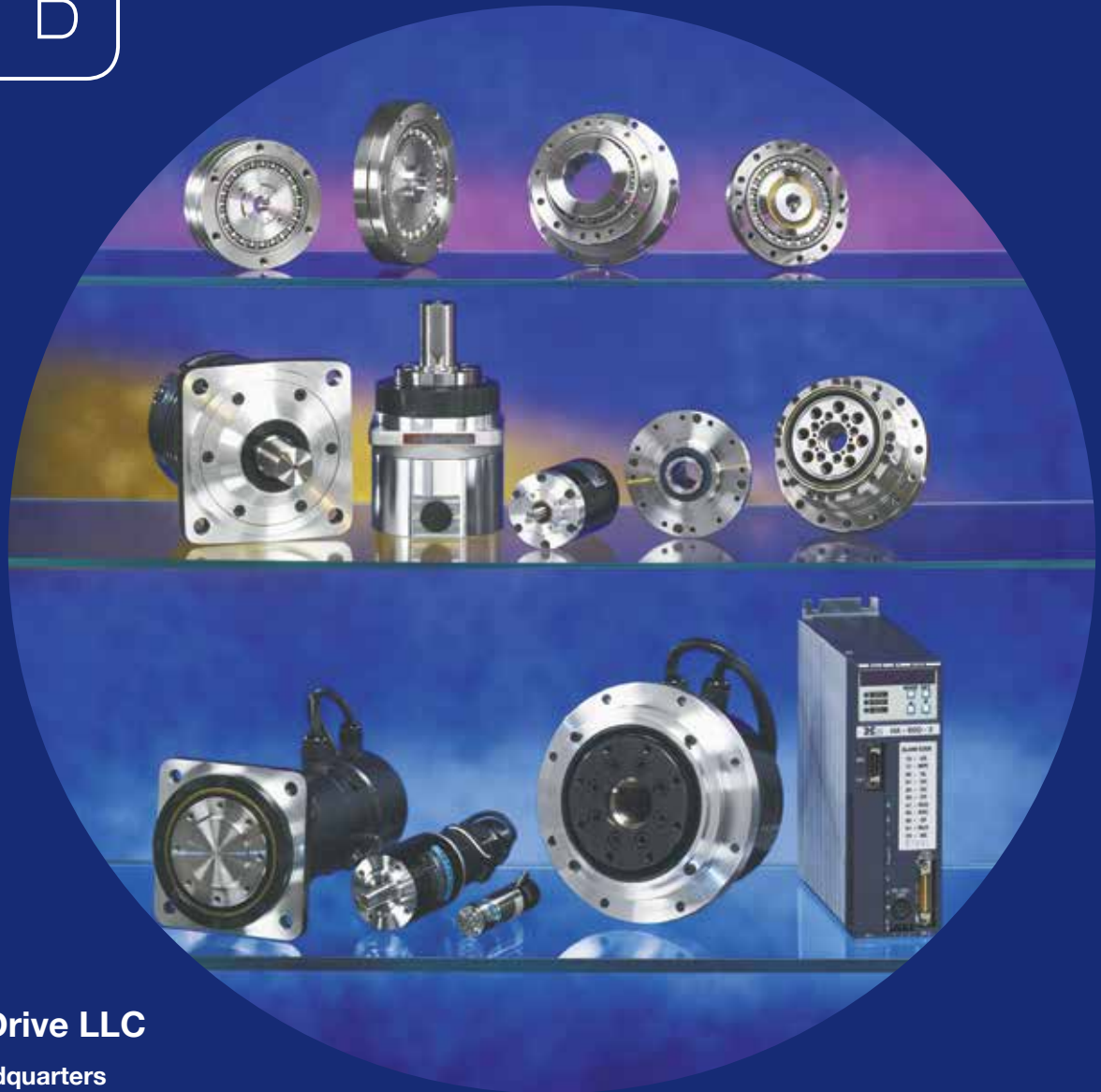

Harmonic Drive LLC

Boston US Headquarters

42 Dunham Ridge
Beverly, MA 01915

New York Sales Office

100 Motor Parkway
Suite 116
Hauppauge, NY 11788

California Sales Office

333 W. San Carlos Street
Suite 1070
San Jose, CA 95110

Chicago Sales Office

137 N. Oak Park Ave., Suite 410
Oak Park, IL 60301

T: 800.921.3332
T: 978.532.1800
F: 978.532.9406

www.HarmonicDrive.net

Group Companies

Harmonic Drive Systems, Inc.
6-25-3 Minami-Ohi, Shinagawa-ku
Tokyo 141-0013, Japan

Harmonic Drive AG
Hoenbergstrasse, 14, D-65555
Limburg/Lahn Germany

Harmonic Drive is a registered trademark of Harmonic Drive LLC.

